

ELASTODICT

User Guide

GeoDict release 2024

Published: July 5, 2024

Reviewed: September 20, 2024

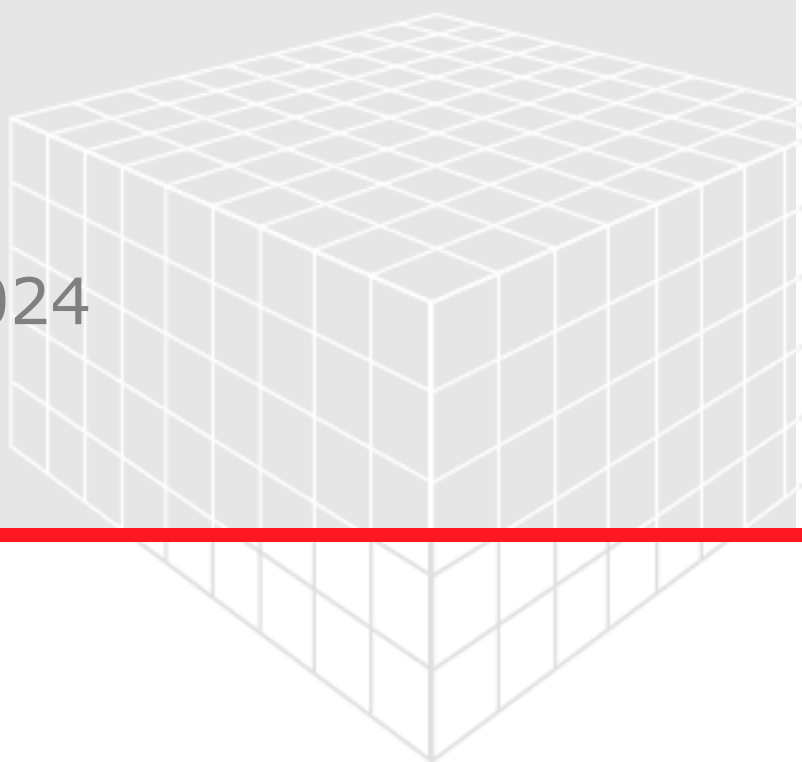

GEO DICT

<https://doi.org/10.30423/userguide.geodict>

© Math2Market GmbH 2024

Citation:

Lilli Burger, Sebastian Rief, Aaron Widera, Barbara Planas. GeoDict 2024 User Guide. ElastoDict handbook. Math2Market GmbH, Germany, doi.org/10.30423/userguide.geodict

All rights reserved. It is not permitted to reproduce the book or parts thereof in any form by photocopy, microfilm or other methods or to transfer it into a language suitable for machines, in particular data processing systems, without the express permission of the publisher. The same applies to the right of public reproduction.

The handbooks in the User Guide series of Math2Market GmbH can be obtained from:

Math2Market GmbH
Richard-Wagner-Strasse 1
67655 Kaiserslautern
Germany

Phone: +49 631 205 605 0
Fax: +49 631 205 605 99
Email: info@math2market.de
Web: www.math2market.de

ELASTODICT: EFFECTIVE ELASTIC PROPERTIES AND LARGE DEFORMATION SIMULATIONS

1

REFERENCES 3

ELASTODICT WORKFLOW 4

SOLID MATERIALS 4

POROUS MATERIALS 4

STARTING ELASTODICT 6

DEFORMATIONS 9

CONSTITUENT MATERIALS 11

MACROSCOPIC LOAD CASE 14

GEOMETRY HANDLING 23

SOLVER 29

OUTPUT 33

EQUATIONS & REFERENCES 36

RESULT FILE (.GDR) 37

BENCHMARK RESULTS FOR DEFORMATIONS 50

FLEXURAL TEST 52

CONSTITUENT MATERIALS 52

MACROSCOPIC LOAD CASE 53

SOLVER 55

OUTPUT 55

EQUATIONS & REFERENCES 55

RESULTS FILE (.GDR) 56

EFFECTIVE STIFFNESS 58

CONSTITUENT MATERIALS 58

LOAD CASE 59

SOLVER 61

OUTPUT 64

POST-PROCESSING 65

EQUATIONS & REFERENCES 68

RESULT FILE (.GDR) 69

BENCHMARK RESULTS FOR EFFECTIVE STIFFNESS 71

EFFECTIVE STIFFNESS (AF) 73

CONSTITUENT MATERIALS 73

LOAD CASE 73

POST-PROCESSING	74
RESULT FILE (.GDR)	74
MECHANICS GEOAPPS	77
CONTACT DETACHMENT	78
STIFFNESS ESTIMATION	83
APPENDIX I: EXAMPLES AND VISUALIZATION	85
ELASTODICT-EFFECTIVE STIFFNESS	85
ELASTODICT - DEFORMATIONS	94
APPENDIX II: NONLINEAR MATERIAL MODELS IN ELASTODICT	101
INTERNAL NONLINEAR MATERIAL LAWS IN FEELMATH	101
GUIDELINES FOR PLASTICITY, DAMAGE AND FAILURE MODELS	106
NONLINEAR MATERIAL LAWS IN GEODICT - REFERENCES	106
SETTING UP THE INTERNAL MATERIAL LAWS	107
MATERIAL FITTING FOR THE INTERNAL MATERIAL LAWS	109
APPENDIX III: USING UMATs FOR CUSTOM MATERIAL LAWS	114
EXAMPLE: SETTING UP A MATERIAL LAW FOR DAMAGE USING AN UMAT	114
EXAMPLE: PLASTIC DEFORMATION WITH A UMAT	122
APPENDIX IV: ELASTICITY THEORY	126
REFERENCES	129
APPENDIX V: EFFECTIVE ELASTIC PROPERTIES	130
ANISOTROPIC ELASTICITY TENSOR	134
ISOTROPIC APPROXIMATION FOR STRAIN EQUIVALENCE (GPA)	135
ESTIMATED PRINCIPAL MATERIAL AXES (PMA)	136
ANISOTROPIC ELASTICITY TENSOR IN PMA COORDINATES	137

ELASTODICT: EFFECTIVE ELASTIC PROPERTIES AND LARGE DEFORMATION SIMULATIONS

The **ElastoDict** module helps in the development of new materials by providing better understanding of their properties. The key to optimizing your materials are accurate simulations on the 3D micro-structure. **ElastoDict** is mainly suited for structural materials, these might be e.g., composite materials, ceramics, metals or foams.

As an example, composite materials play a crucial role for light weight applications, but the analysis of their behavior is challenging due to the highly anisotropic behavior and the complex damage mechanisms they exhibit. The expensive, time consuming and often impracticable experimental tests for the study of composites can be supplemented or replaced by simulation.

Using simulation to find answers to mechanical properties and deformation questions is key in many application areas, where the target variables do not necessarily need to be mechanical properties of the materials. For example, the **ElastoDict** module can be used to simulate how the clamping pressure changes the structure of a gas diffusion layer (GDL) in a PEM fuel cell, or how the properties of rock samples change under in-situ conditions.

All these **ElastoDict** simulations run at high-speed and are extremely memory-efficient thanks to the integrated [FeelMath](#) solver developed at the Fraunhofer ITWM.

Since **GeoDict** 2022, the LIR solver is additionally available for **ElastoDict**-Effective Stiffness.

ElastoDict contains the following sub-modules:

■ **Deformations**

ElastoDict-Deformations simulates nonlinear large deformations. For example, a standard tensile experiment in an arbitrary direction of the 3D micro-structure can be set up. The models of the constituent materials might contain damage, failure, plastic deformation, viscous effects, and many more. For linear elastic materials, new material contacts in the structure can be detected during the simulation. To model the constituent materials, Abaqus UMAT's can be used to include all kinds of possible effects in the nonlinear simulation. Results of the simulation are e.g., a stress-strain curve and local information on the regions where damage sets in and the material ends up failing.

■ **Flexural Test**

With the Flexural Test option in **ElastoDict**, the reaction of a material to bending loads can be analyzed.

■ **Effective Stiffness**

ElastoDict-Effective Stiffness computes the linear elastic properties of complex micro-structures by solving the corresponding partial differential equation on the 3D image or model. For Effective Stiffness, two solvers are available: [FeelMath](#) and LIR. The results include the local stresses and strains, the complete stiffness tensor, and the information on the orthotropic, transversal isotropic or isotropic character of the material, indicative of directionally dependent properties. Additionally, many post-processing steps can be carried out on the **ElastoDict**-Effective Stiffness results.

■ **Effective Stiffness (AF)**

ElastoDict-Effective Stiffness (AF) computes analytic approximations and bounds for the linear elastic properties of complex micro-structures. The computation is very fast, as no partial differential equation is solved, and gives a first approximation of the material behavior.

■ **Mechanics GeoApps**

This section contains GeoApps which use the functionality of **ElastoDict**. Currently, two **GeoApps** are available:

- the ***Stiffness Estimation*** **GeoApp** helps to estimate the stiffness on an unknown material
- the ***Contact Detachment*** **GeoApp** is used to set up a simulation with the possibility of objects detaching from each other.

REFERENCES

- [1] H. Moulinec, P. Suquet: **A numerical method for computing the overall response of nonlinear composites with complex microstructure.** *Computer Methods in Applied Mechanics and Engineering*, Volume 157, Issues 1-2 (1998), pp 69-94, [https://doi.org/10.1016/S0045-7825\(97\)00218-1](https://doi.org/10.1016/S0045-7825(97)00218-1)
- [2] J.Th. Browaeys, S. Chevrot; 2004; **Decomposition of the elastic tensor and geophysical applications.** *Geophysical Journal International* 159(2); p. 667-678., <https://doi.org/10.1111/j.1365-246X.2004.02415.x>
- [3] V. Rutka, A. Wiegmann; 2006; **Explicit jump immersed interface method for virtual material design of the effective elastic moduli of composite materials;** *Numerical Algorithms* 43; p. 309-330., <https://doi.org/10.1007/s11075-007-9063-9>
- [4] V. Rutka, A. Wiegmann, H. Andrä; 2006; **EJIIM for calculation of effective elastic moduli in 3D linear elasticity;** *Berichte des Fraunhofer ITWM*, Nr. 93; p. 1-22.
- [5] M. Kabel, D. Merkert, M. Schneider: **Use of composite voxels in FFT-based homogenization.** *Computer Methods in Applied Mechanics and Engineering*, Volume 294 (2015), pp. 168-188, <http://dx.doi.org/10.1016/j.cma.2015.06.003>
- [6] M. Schneider, F. Ospald, M. Kabel: **Computational homogenization of elasticity on a staggered grid.** *Int. Journal for Numerical Methods in Engineering*, Volume 105, Issue 9 (2016), pp. 693-720, <https://doi.org/10.1002/nme.5008>
- [7] M. Kabel, S. Fliegner, M. Schneider: **Mixed boundary conditions for FFT-based homogenization at finite strains.** *Computational Mechanics*, Volume 57, Number 2 (2016), pp 193-210, <http://dx.doi.org/10.1007/s00466-015-1227-1>
- [8] M. Kabel, A. Fink, M. Schneider: **The composite voxel technique for inelastic problems.** *Computer Methods in Applied Mechanics and Engineering*, Volume 322 (2017), pp 396-418, <https://doi.org/10.1016/j.cma.2017.04.025>
- [9] H. Grimm-Strele, M. Kabel: **Runtime optimization of a memory efficient CG solver for FFT-based homogenization: implementation details and scaling results for linear elasticity.** *Computational Mechanics*, Volume 64, Volume 5 (2019), pp 1339-1345, <https://doi.org/10.1007/s00466-019-01713-3>
- [10] H. Grimm-Strele, M. Kabel: **Fast Fourier transform based homogenization with mixed uniform boundary conditions.** *International Journal for Numerical Methods in Engineering* (2021), <https://doi.org/10.1002/nme.6830>
- [11] M. Kabel; 2022; **Mixed strain/stress gradient loadings for FFT-based computational homogenization methods;** *Computational Mechanics* 70., <https://doi.org/10.1007/s00466-022-02168-9>

ELASTODICT WORKFLOW

The computation of mechanical properties in **ElastoDict** usually follows these steps:

1. Import 3D image data in the form of a stack of (μ)CT scan or FIB-SEM images of an existing material or generate a new structure model in **GeoDict**.
2. Start **ElastoDict** and
 - choose the adequate solver,
 - set material parameters using the **GeoDict** material database,
 - run the mechanical properties computations
 - analyze the results

Solid and porous structures can be used as input for computations with **ElastoDict**. The mechanical properties of all constituent materials must be given. Including the pore/matrix material, **GeoDict** handles structures with up to 256 different constituent materials.

As useful convention, for solid materials, the background (Material ID 0) contributes to the computation and is referred to as matrix material. For porous media, Material ID 0 is used for the pore space (void space).

SOLID MATERIALS

In solid structures, all constituent materials have non-zero physical material parameters (e.g., Poisson's ratio and Young's modulus for linear elastic materials; see the **Constituent Materials** tab in page [11](#)). In structures consisting of multiple solid materials, like e.g., composite materials, **ElastoDict** applies perfect contact at the interfaces between different materials. A typical example for a solid structure is a glass fiber reinforced composite.

Many different material models (Plasticity, visco-plasticity, damage, ...) are available in **GeoDict** and the user can implement his/her own [Abaqus UMATs](#).

POROUS MATERIALS

Porous structures in **GeoDict** are materials where at least one constituent material is selected as Pore (Fluid) material, this means its Young's Modulus and Poisson's ratio are both set to zero. No stresses can occur in the pore space. Examples of porous structures are e.g. nonwovens and foams.

It is a requirement of all **ElastoDict** simulations that a continuous load path exists through the structure. This means that the solid materials must form a connected component in the load direction. Otherwise, an error message below is shown, and the simulation cannot be started.

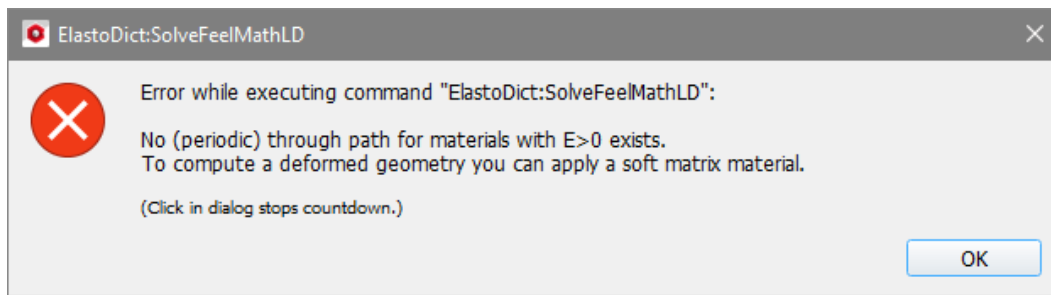

For materials in the pore space, a pore pressure can be set which leads to stresses in the surrounding solid materials.

Some structures whose mechanical properties can be calculated with **ElastoDict** are:

Isotropic fibrous microstructure model generated using **FiberGeo**



Nickel Foam microstructure model generated using **FoamGeo**

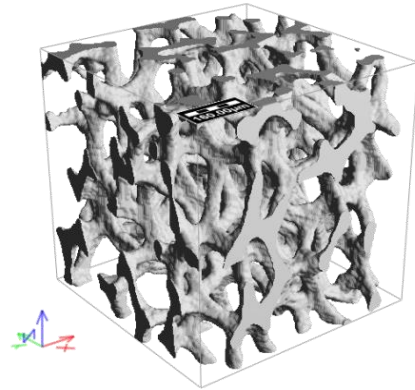

Berea Sandstone modeled from imported 3D data using **ImportGeo-Vol**



Glass fiber reinforced polymer model generated using **FiberGeo**



STARTING ELASTODICT

Start **ElastoDict** by selecting **Predict** → **ElastoDict** in the menu bar.

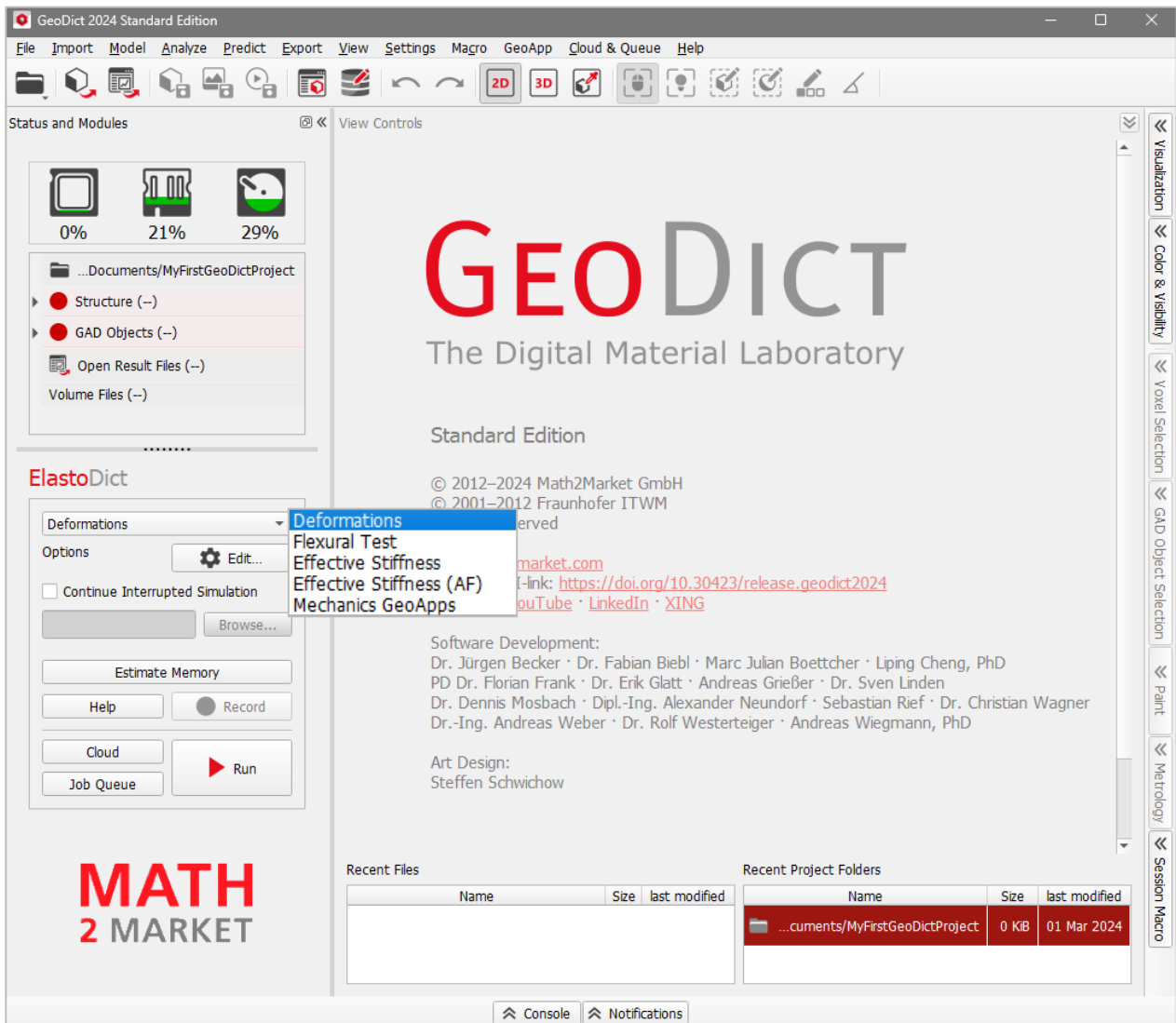

In the **ElastoDict** section, located on the left side of the GUI, the solvers are selectable from the pull-down menu:

1. **Deformations** for the computation of large deformations.
2. **Flexural Test** for the computation of bending experiments.
3. **Effective Stiffness** for the computation of effective stiffness based on numeric computations.
4. **Effective Stiffness (AF)** for the computation of effective stiffness based on analytic formulas.
5. **Mechanics GeoApps** contains apps which use the functionality of **ElastoDict** for specific applications.

The settings (Options) can be modified through the **Edit...** button. The default parameters can be changed to user-defined parameters for the computation of interest.

For **Deformations** and **Effective Stiffness**, the **Estimate Memory** button is present in the **ElastoDict** section. When the structure of interest is shown in the Visualization area, clicking **Estimate Memory** calculates the memory needed for the computations based on the size of the structure and the parameters entered in the solver options.

After entering the **Solver Options**, click the **Run** button in the **ElastoDict** section to start the computations. A progress dialog opens to follow the computations.

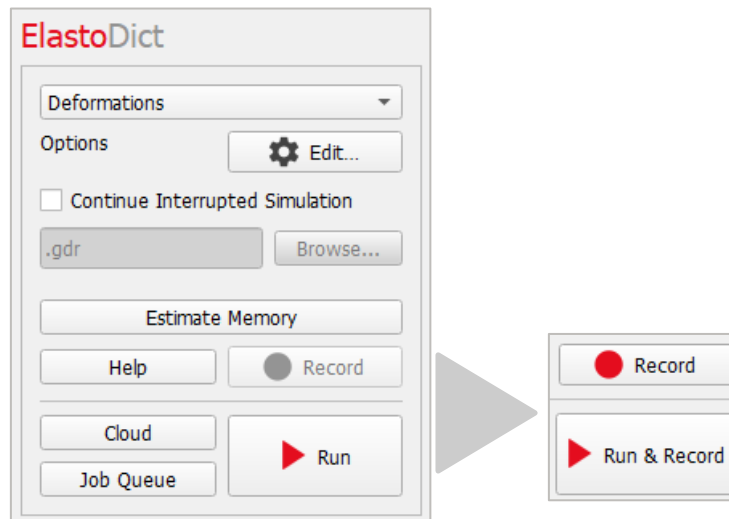

When recording a macro, the **Record** button becomes active, and the **Run** button changes to **Run & Record**.

Click **Help** to access this [ElastoDict](#) handbook through our web page.

The button **Cloud** allows to perform the calculations in the **GeoDict** Cloud and with **Job Queue** the simulation run can be executed on a job queue server. More information on how to start a calculation in the cloud or the job queue can be found in the [High Performance Computing](#) handbook of the **GeoDict** User Guide.

If interested in cloud simulations contact Math2Market to apply for a **GeoDict** cloud license.

During the computation, the **ElastoDict** solver process can be cancelled or stopped by clicking the **Cancel** or **Stop** button in the progress dialog.

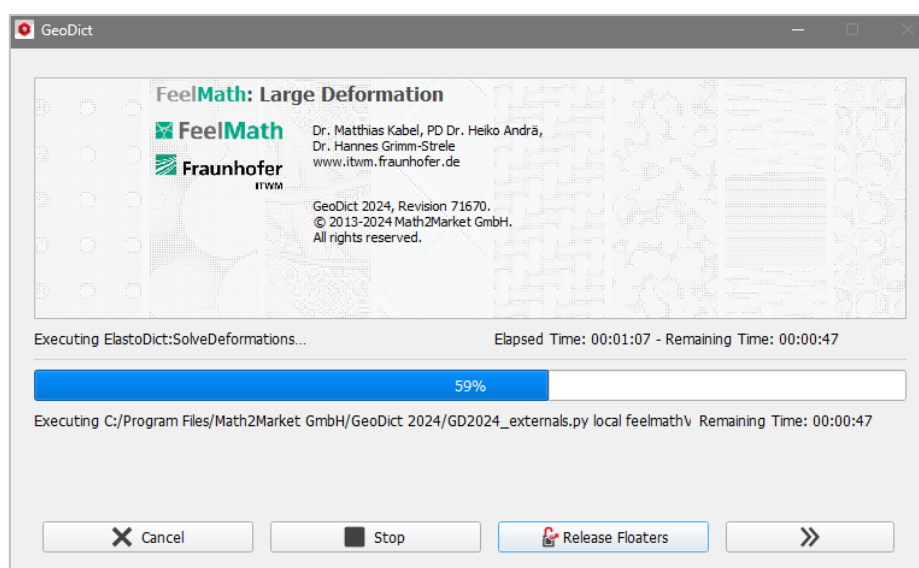

With **Cancel**, the computation is terminated, and no further action is taken. With **Stop**, the computation is terminated, and the results file is updated to the current state of the computation. Then, the result file is loaded and shown in the Result Viewer. With the  button, the console is opened which shows additional information about the solver run.

The **Release Floaters** button is for floating license users only. Pressing this button frees all non-required floaters and makes them available again for other users, see the [Settings](#) section of the *GeoDict GUI, Menu, and Toolbar Reference* handbook for more information.

Depending on the solver's internal processes and actual memory usage, terminating the computation may not be instantaneous.

DEFORMATIONS

Click the **Options' Edit...** button to set the simulations settings for deformation simulations.

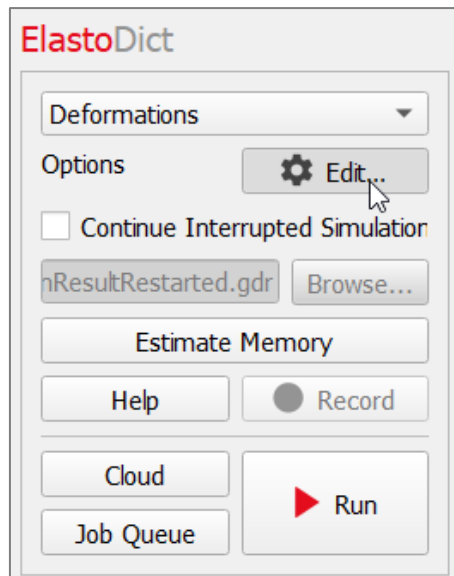

In the **Large Deformation Options** dialog, choose a **Result File Name (*.gdr)** according to your current project.

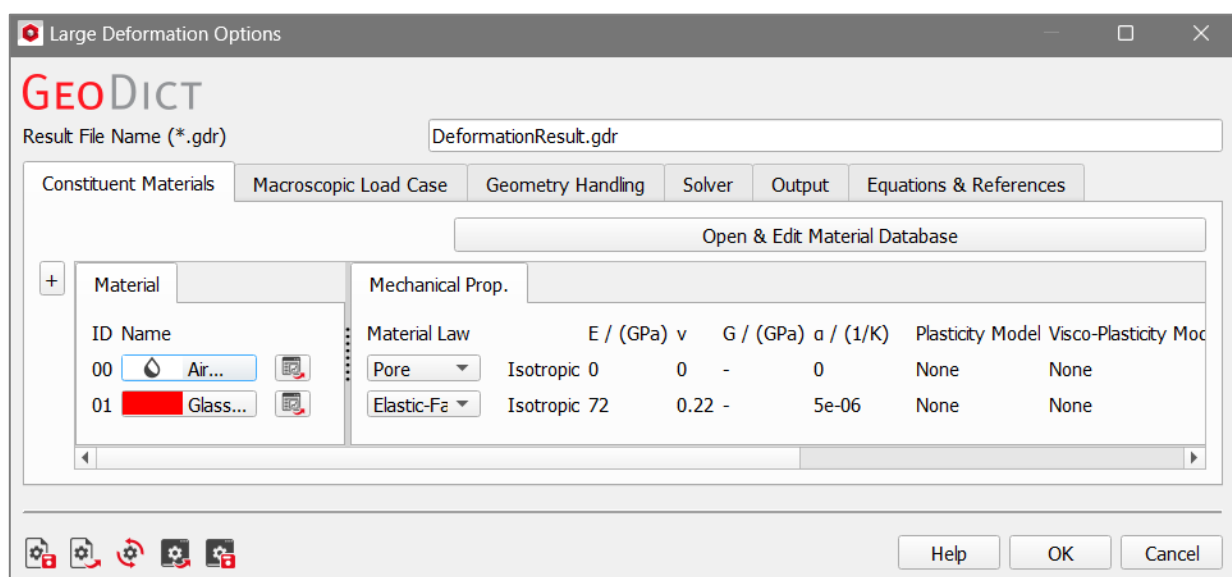

If a **GeoDict** results file (*.gdr) with the given name already exists in the project folder, a warning message is shown at the start of the creation process.

The user may decide to back-up the old file, to overwrite it, or to choose a new file name. If no action is taken, the default option **Back-Up** is automatically chosen after a waiting time. Then, the old results files are copied to the folder *00GeoDictBackUp* in the current project folder.

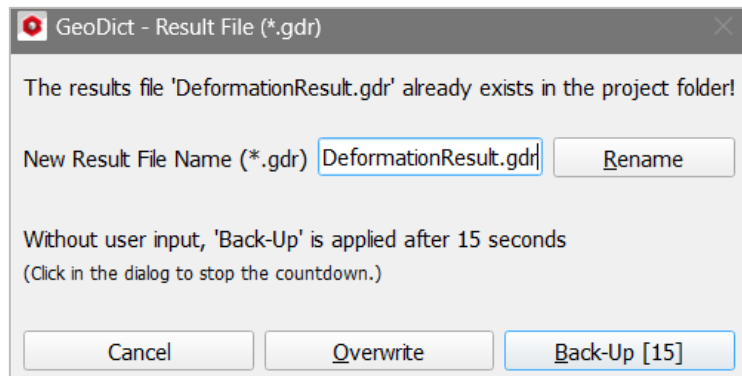

Additional to the results file with the given name, also a corresponding results folder with the same name is written into the current **GeoDict** project folder. The results file in combination with the results folder contains all information about the current run and allows to reproduce the simulation.

RESTARTING A SIMULATION

Deformation simulations can contain many steps, and therefore it may be necessary to interrupt a simulation. Such simulations can be restarted with the option **Continue interrupted simulation**. Click **Browse** to select the corresponding result file and then **Run** to restart the simulation.

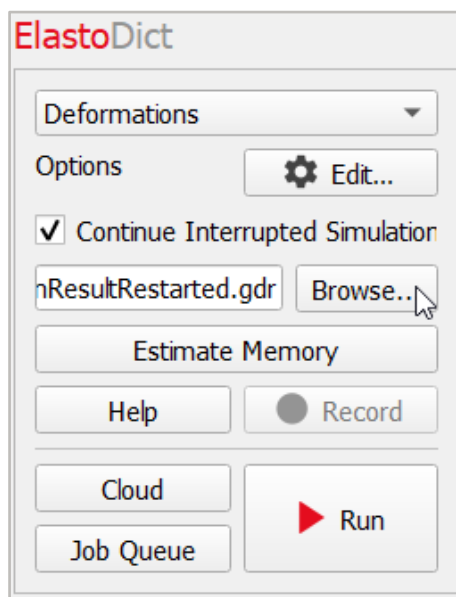

For more information about the requirements for continuing interrupted simulations, see page [34](#).

If a simulation cannot be continued, a corresponding error message is shown.

CONSTITUENT MATERIALS

The materials in the structure model need to be defined under the **Constituent Materials** tab, so that their mechanical parameters, such as the Young's modulus (E) and the Poisson's ratio (ν), are taken into account.

The material for a material ID can be selected by clicking on the corresponding material name. Then, the **Material Selector** dialog is opened.

The mechanical properties of the structure's constituent materials are taken directly from the **GeoDict** Material Database. To enter the material parameters for a linear elastic material manually, choose **Manual (Solid)** as material.

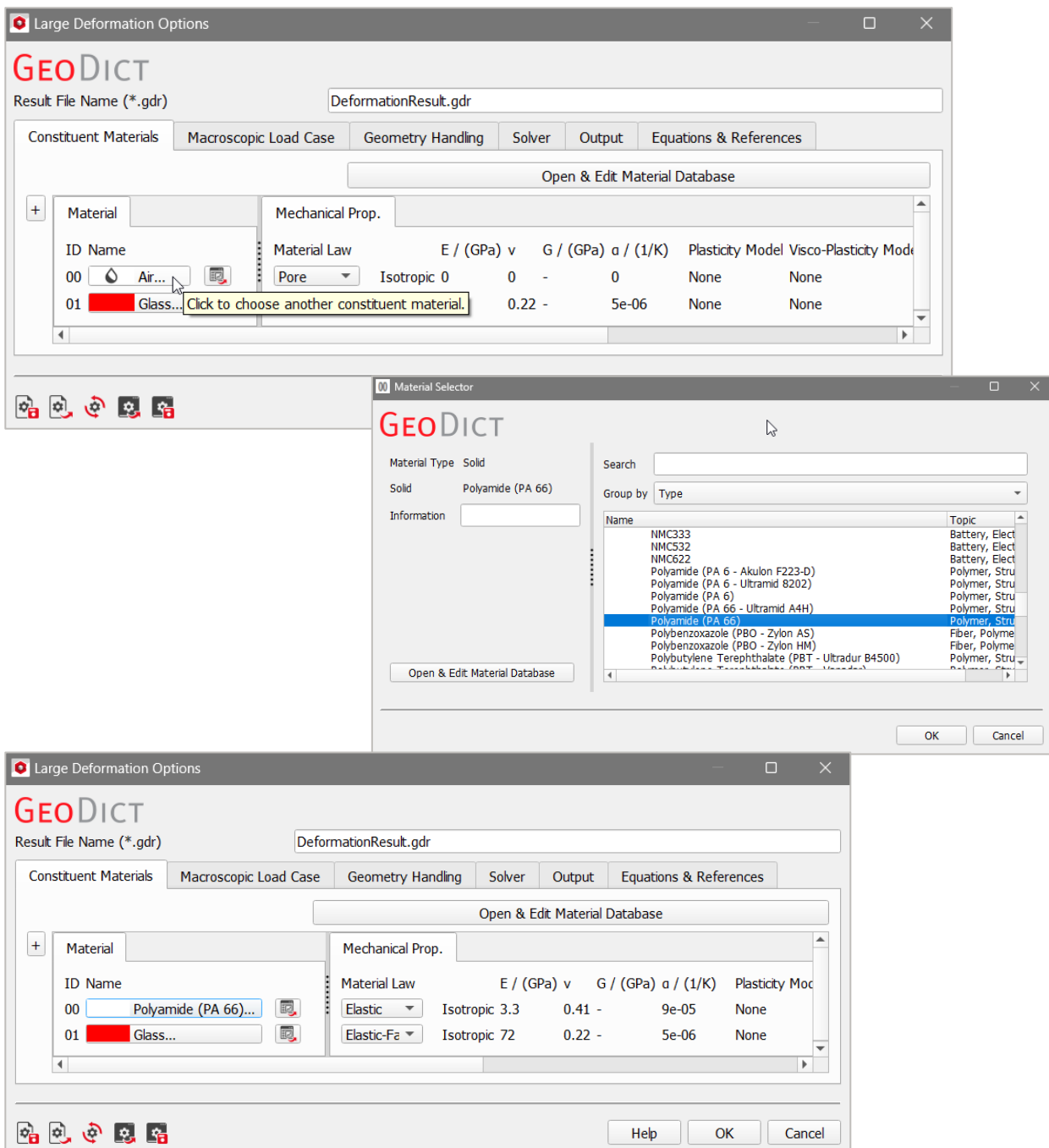

Any values entered manually e.g., those for a user-defined constituent material, can also be added to the material database through the **Edit Material Database...** button. Nonlinear materials can also be created in the **GeoDict** Material Database.

For materials from the material database, the **View...** button on the right in the **Constituent Materials** tab shows all parameters of the material.

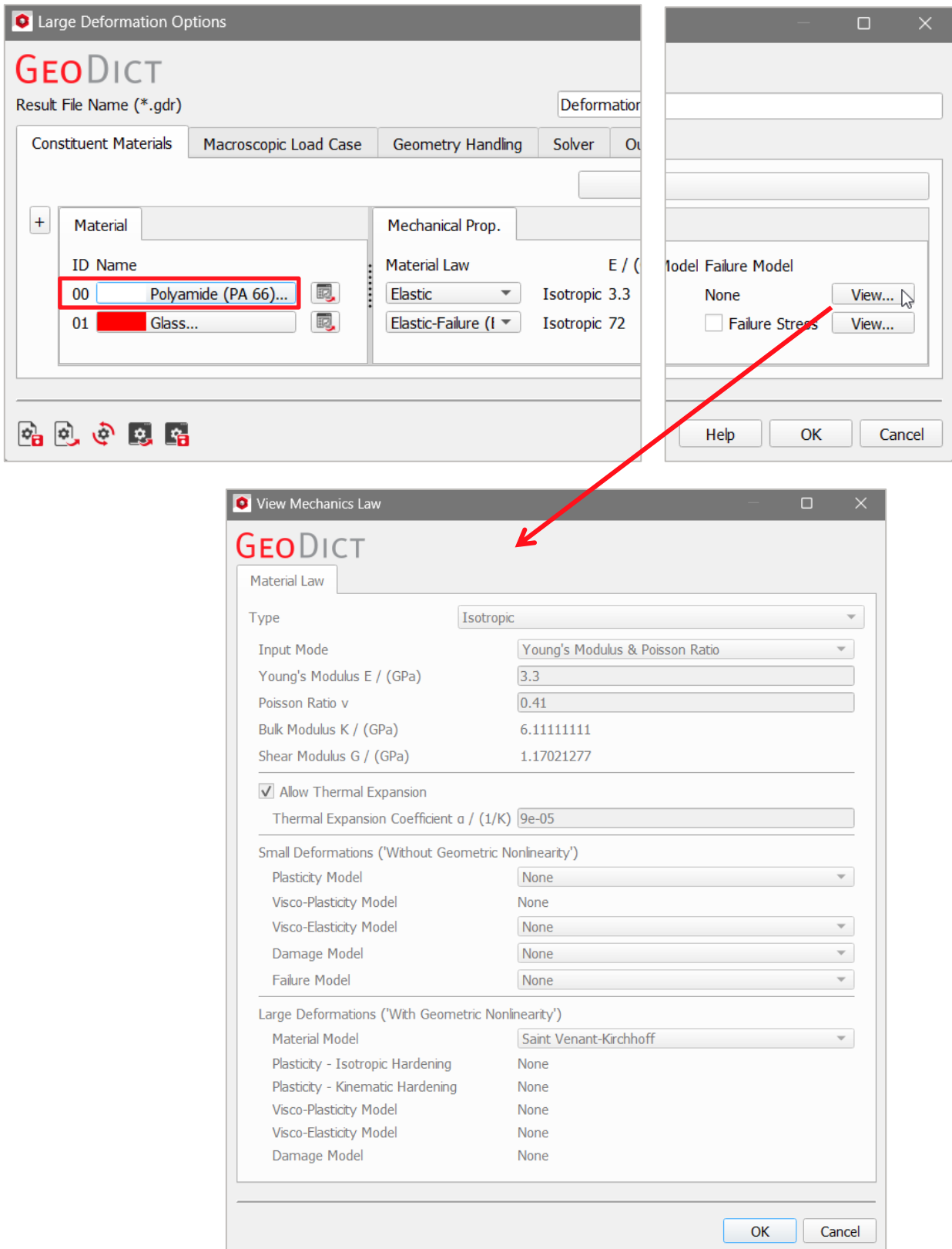

For **Manual** materials, the **View...** button on the right in the **Constituent Materials** tab changes to **Edit...** and allows to edit all parameters of the material.

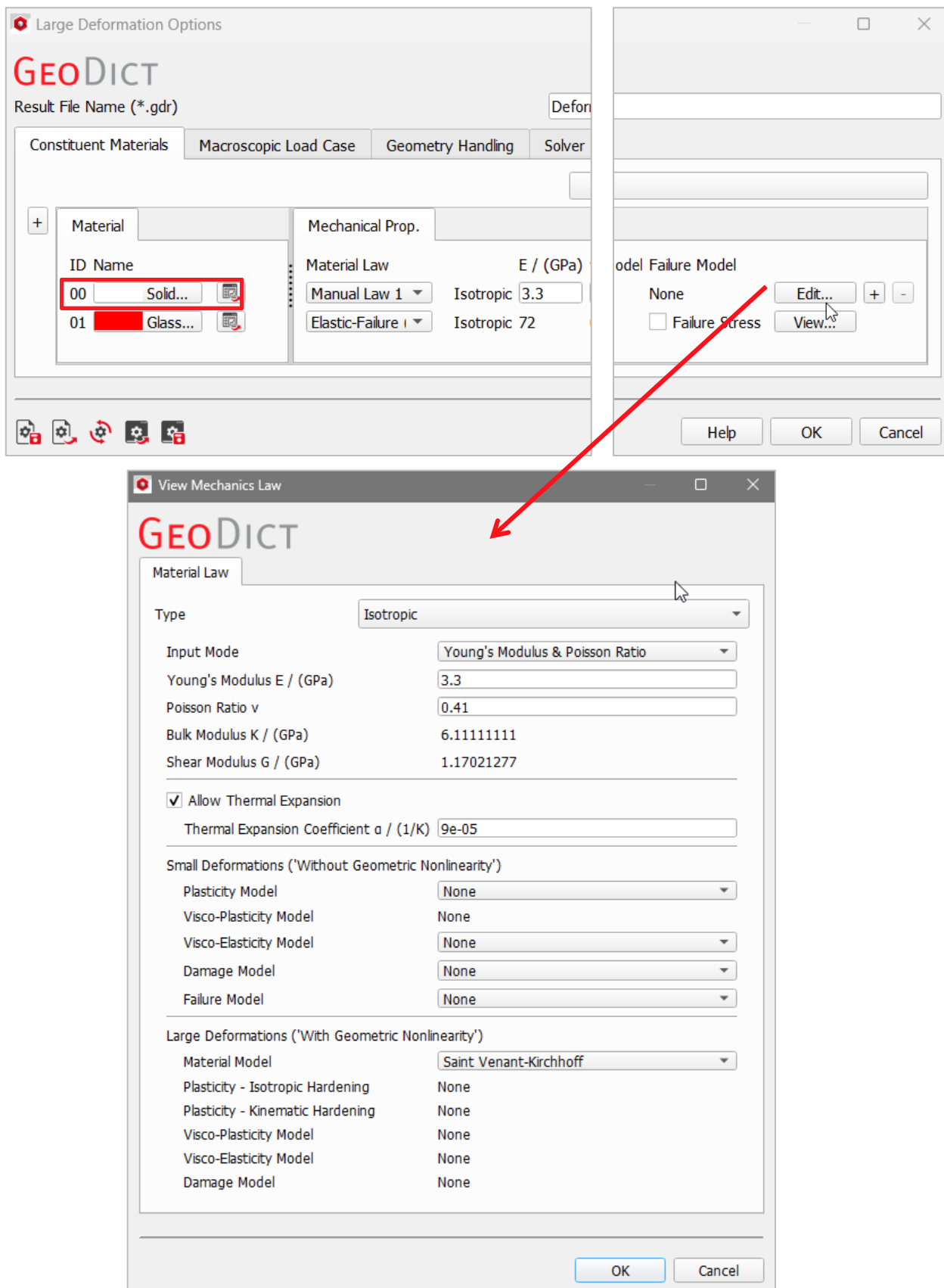

More information on editing, expanding, and using the GeoDict Material Database is available in the [Material Database](#) handbook.

MACROSCOPIC LOAD CASE

The parameters which define the general conditions of the **Macroscopic Load Case** are **Experiment** and **Load Type**. Their choice defines which other parameters are available for the experiment.

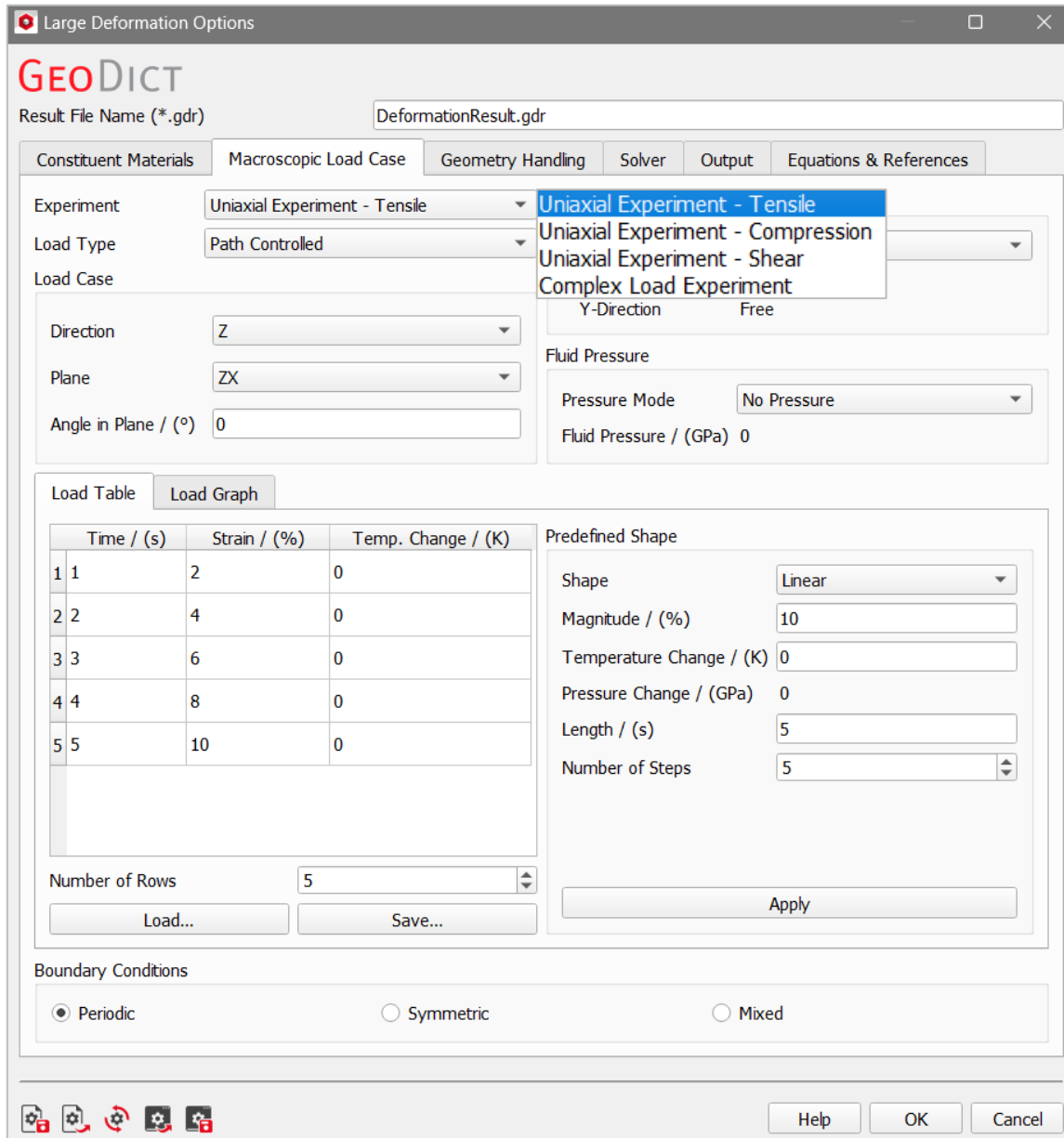

EXPERIMENT

- **Uniaxial Experiment – Tensile / Compression / Shear** allows to set up experiments with one load direction (Tensile, Compression or Shear Experiments). The load can be time-dependent, e.g., cyclic. See more on Uniaxial Experiment starting on page [16](#).
- **Complex Load Experiment** allows to define more elaborate load scenarios, e.g., a tensile experiment followed by a shear load or multiple load directions at the same time. The load directions can be defined freely as a combination of normal and shear loads. See more on Complex Load Experiment starting on page [20](#).

LOAD TYPE

■ Path Controlled:

specify the *mean strain* in the geometry (for geometric linear experiments) or the *mean displacement gradient* in the geometry (for geometric nonlinear experiments) in the load direction.

■ Force Controlled:

Specify the *mean stress* in the geometry (for geometric linear experiments) or the *mean nominal stress* in the geometry (for geometric nonlinear experiments) in the load direction. It is important to note that the mean stress is computed with respect to the complete geometry. If a structure consists of solids and pore space, this means that the average load on the solids is larger than the given mean stress, since the load in the pore space is zero.

Generally, **Path controlled** should be preferred over **Force Controlled** if possible. One of the challenges with **Force Controlled** is the fact that the Strain-Stress curves for plastic materials are often very flat: This means that a small change in stress can lead to a very large change in strain. On the other hand, a small change in strain leads to an even smaller change in stress. Therefore, the **Path Controlled** simulation is much easier to compute. For simulations with damage, **Force controlled** may be even impossible to solve (because the given stress might be higher than the maximal stress allowed by the material), while **Path Controlled** can always be solved (see also page [106](#)).

BOUNDARY CONDITIONS

Here, the domain boundary conditions for the strain (and stress respectively) may be set to **Periodic**, **Symmetric**, or **Mixed**. Note that displacements do not need to hold these boundary conditions.

In general, periodic boundary conditions should be used for periodic structures, whereas otherwise symmetric or mixed boundary conditions may be applied.

Mixed boundary conditions mean that symmetric boundary conditions apply in the load direction, whereas periodic boundary conditions apply in the tangential directions. Mixed boundary conditions can only be used for tensile, or compression loads along the coordinate directions. In the figure below, periodic and symmetric boundary conditions are illustrated for a non-periodic structure.

The structure below was created as an example and does not have a real counterpart.

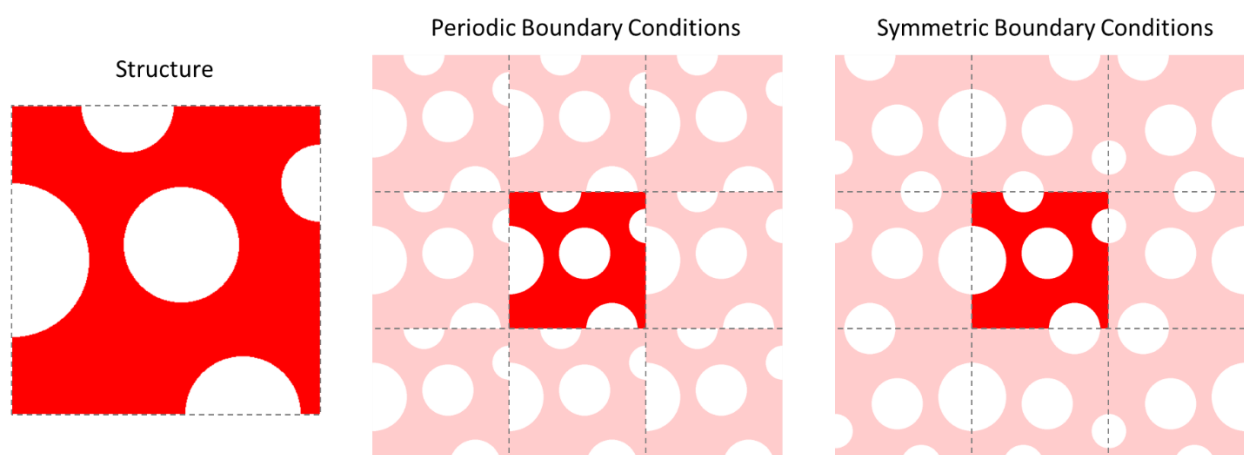

When periodic boundary conditions are applied to non-periodic structures, it might lead to stress peaks at the boundaries as illustrated below for a uniaxial load.

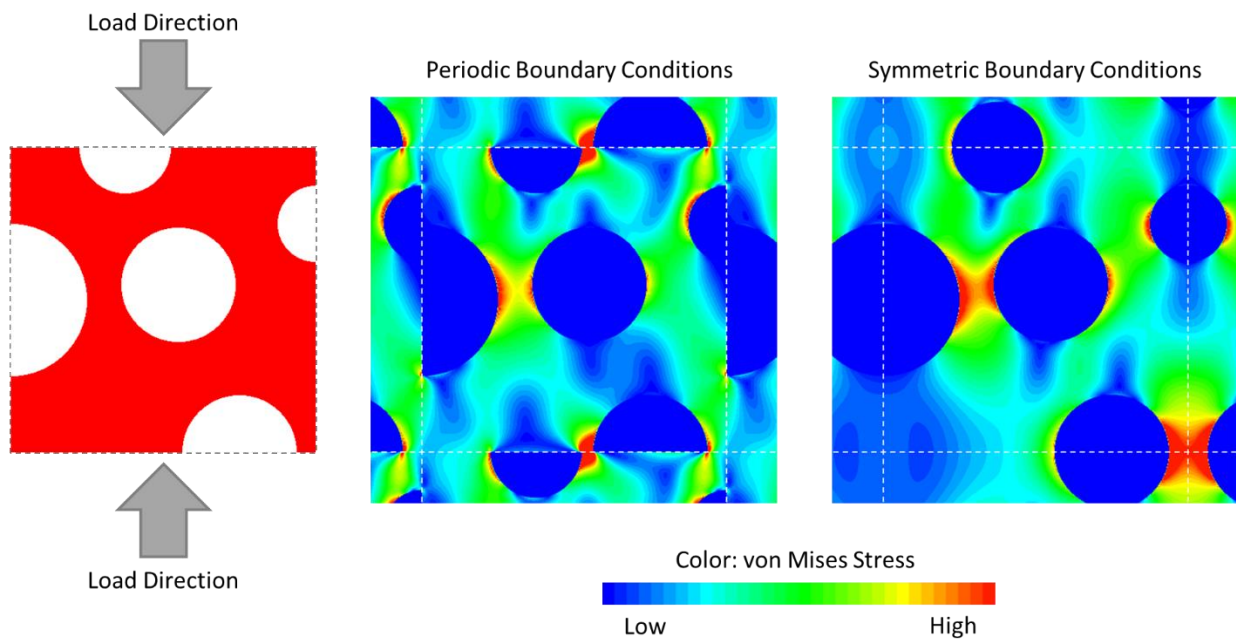

However, simulations with periodic boundary conditions are much faster and need less memory than simulations with symmetric boundary conditions.

In many cases, for example for composite structures with low fiber percentage, the results for periodic boundary conditions are comparable with the results for symmetric boundary conditions even if the analyzed structure is not periodic. Therefore, it is recommended to work with periodic boundary conditions until the best simulation settings are found and only use symmetric boundary conditions in the final simulation.

UNIAXIAL EXPERIMENT AND COMPLEX LOAD EXPERIMENT

Uniaxial Experiment

In a **Uniaxial Experiment**, the load is applied in one given direction. This direction can be either given by one of the coordinate directions (X, Y, Z), a given angle to one of the coordinate directions in each coordinate plane (e.g., XZ or YZ), or a shear experiment can be defined.

The available load types are **Tensile**, **Compression** or **Shear**. The choice of **Tensile** or **Compression** only affects the sign of the loads, for example negative tension equals compression.

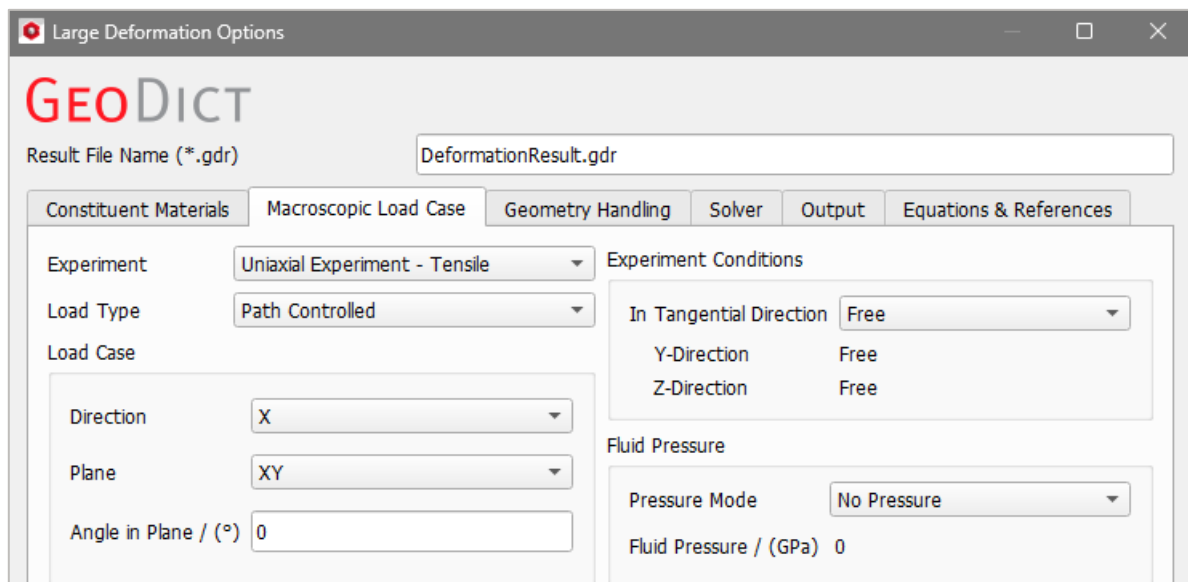

Load Case

The choices available for the **Load Case** vary depending on whether **Tensile**, **Compression** or **Shear** is selected. For **Tensile** and **Compression** experiments, a direction, a Plane, and an **Angle in Plane** must be defined. For **Shear**, the **Shear Load** must be selected. If **Without Geometric Nonlinearity** under the **Geometry Handling** tab is chosen, three different shear loads are available: Here, the theory of small deformations applies, therefore the Shear in XY direction corresponds the shear in YX direction. Thus, three different shear options are available in this case: XY, XZ and YZ.

When the theory of small deformations does not apply (**With Geometric Nonlinearity**), there are three different cases for shear in X and Y directions: Shear in XY direction, shear in YX direction (the deformation gradient is asymmetric in those cases) and symmetric shear in X and Y directions (this is a superposition of the two other cases, the deformation gradient is symmetric in this case). Thus, nine different shear options are available for the geometric nonlinear case.

Refer to the [Geometry Handling](#) section for more information about the geometry options.

Experiment Conditions

The load conditions in the directions tangential to the load direction can be **Free** (zero mean stress/nominal stress in the geometry), **Confined** (zero mean strain/displacement gradient in the geometry) or **Mixed**. Free means that the structure can expand or contract freely to the load direction, whereas there is no expansion/contraction for confined boundary conditions. With Mixed tangential boundary conditions, two different conditions (**Free** or **Confined**) can be selected for the two tangential directions.

Fluid Pressure

When the structure for the simulation contains pores, a fluid pressure model can be selected. With **No Pressure**, no pressure is applied (this is the default case). With **Fixed Pressure**, a fixed pressure can be given. This fixed pressure is applied at the start of the **ElastoDict** computations. With the third option, **Pressure Per Step**, the applied pressure can be defined for each simulation step. These pressure steps must be entered in the **Load Table** (see further explanation below).

The pressure is always applied to all fluids in the structure. This means that it is not only applied to pores in the material, but also to the fluid which surrounds the structure.

The screenshot displays the ElastoDict software interface for configuring fluid pressure. It includes two inset boxes at the top showing different pressure modes: 'No Pressure' and 'Fixed Pressure'. The main window shows the 'Pressure Per Step' mode selected. A table lists the pressure values for each step, and a dropdown menu for 'Predefined Shape' is open, showing options like 'Linear', 'Sawtooth', and 'Sine'.

Time / (s)	Stress / (GPa)	Temp. Change / (K)	Fluid Pressure / (GPa)
1	2	0	1
2	4	0	2
3	6	0	3
4	8	0	4
5	10	0	5

Load definition (Load Table and Predefined Shape)

The load steps to be computed need to be specified in the **Load Table**, where a plot of the load curve can be seen under the **Load Graph** subtab. It is also possible to use a load curve of **Predefined Shape** like **Linear**, **Sawtooth**, or **Sine**, by selecting it from the pull-down menu on the right and clicking **Apply**, to set it in the **Load Table** and visualize it under **Load Graph**.

For the shapes **Linear** and **Sine** there is also the option to define the thermal conditions by setting the **Temperature Change / (K)** for the **Linear** shape and **Temperature Amplitude / (K)** for the **Sine** shape

In Case **Pressure Mode** → **Pressure Per Step** is chosen, additionally to the load and temperature curve, the fluid pressure curve can be defined in **Predefined Shape** by setting the **Pressure Change / (GPa)** for the **Linear** shape or **Pressure Amplitude / (GPa)** for the **Sine** shape.

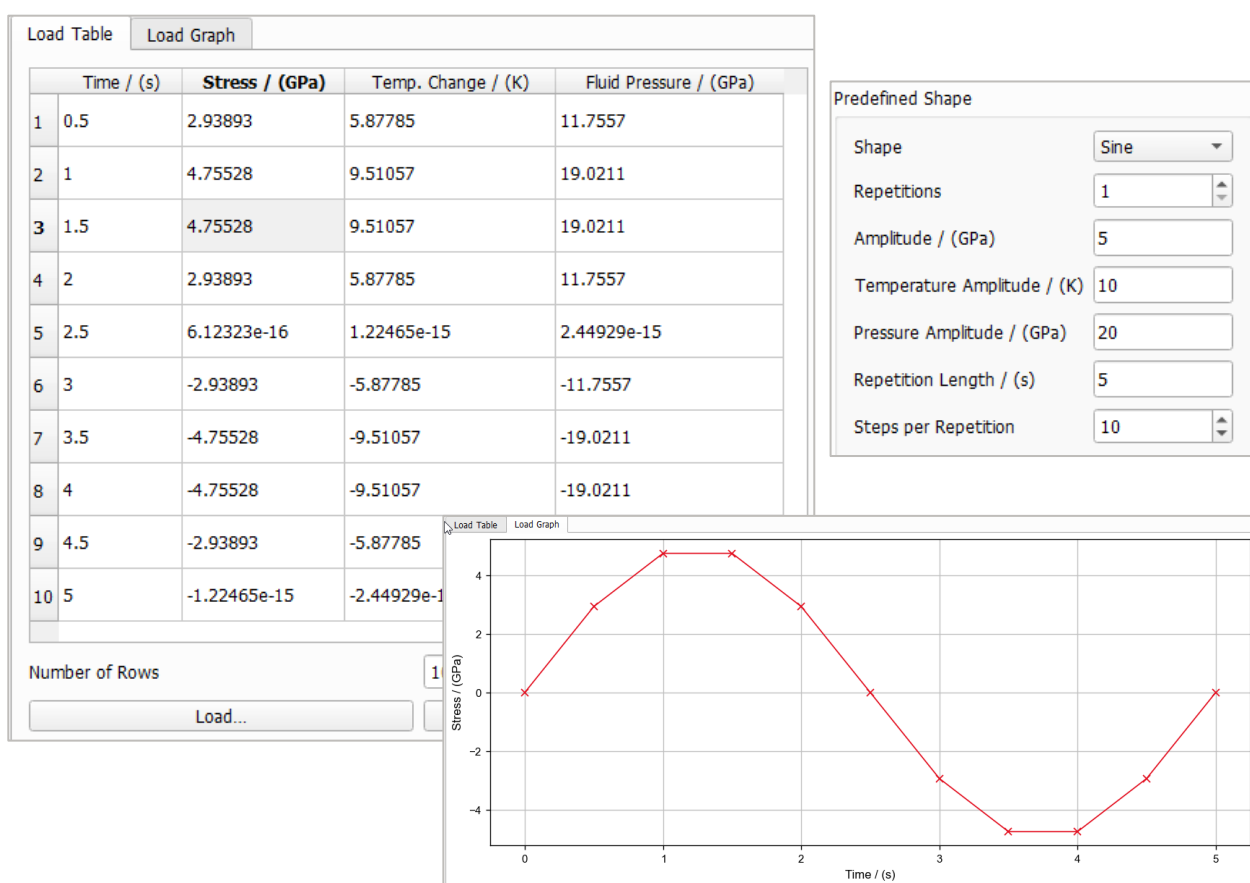

The load table can be loaded from and saved to a *.txt file with the **Load...** and **Save...** buttons.



Alternatively, the data from the load table can be entered from other software like Microsoft Excel® via copy and paste.

The time information from the load table is only used if the materials in the structure have a time-dependent behavior. When working with UMATs, this time information is passed to the UMAT.

Complex Load Experiment

For a **Complex Load Experiment**, the complete mean stress (nominal stress) or strain (displacement gradient) tensor for the geometry can be defined.

In this way, combinations of multiple loads directions are possible (e.g., biaxial load, triaxial load...). The load directions can be defined freely as a combination of normal and shear loads. In the screenshot below, a tensile strain of 2 % in X-direction, a shear load of 1 % in XY-direction and a tensile strain of 5 % in Z-direction is set.

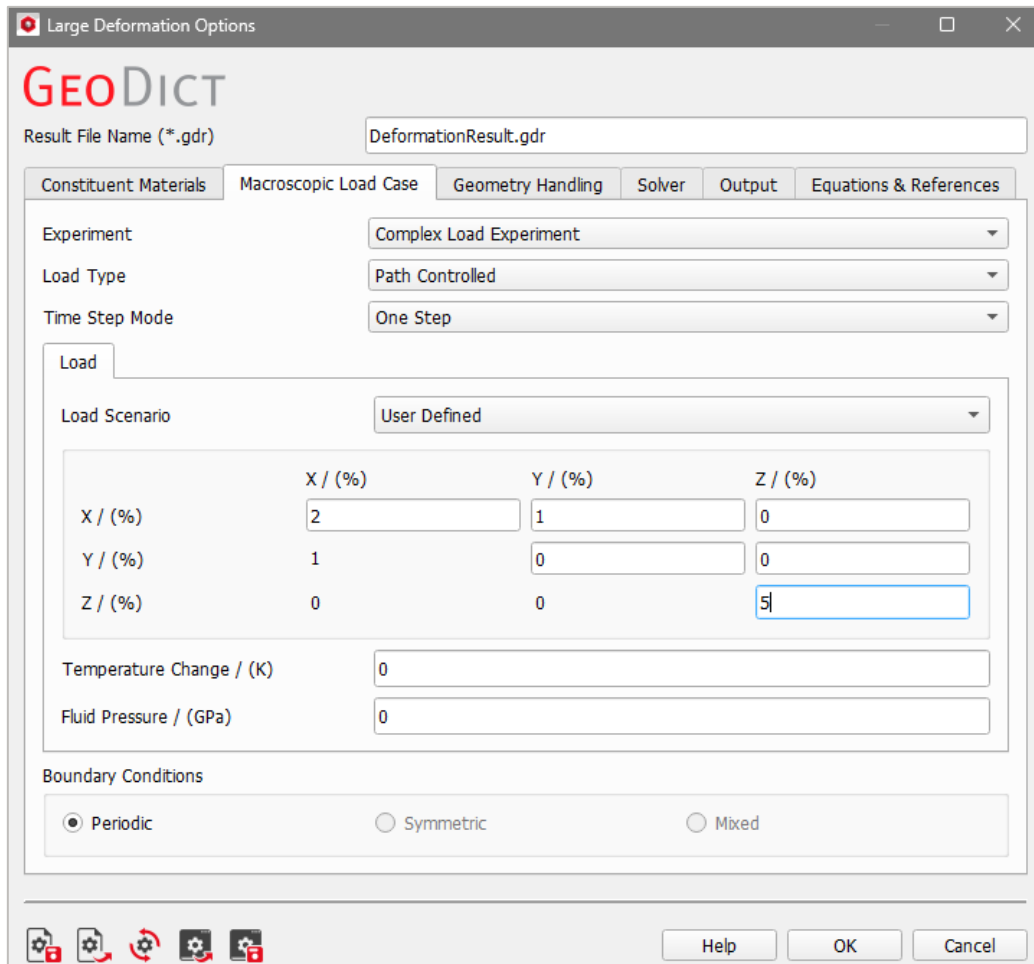

Possible options for **Time Step Mode** are **One Step** or **Time Series**.

Whereas **One Step** consists of a single load step, a **Time Series** may consist of several load steps (Length of Load Sequence: 1, 2, 3...), where each load step (Load 1, Load 2, Load 3... tabs) is defined by a **Load End Time**, number of **Time Steps per Load** and a **Load Scenario**. The **Load Scenario** can be **Tensile**, **Compression**, **Shear** or **User Defined**.

The total time of the load is the difference of the current **Load End Time** and the previous **Load End Time**; therefore, the load end time must be strictly increasing. Each load is divided in a given number of **Time Steps per Load**. The concept is illustrated in the following figure:

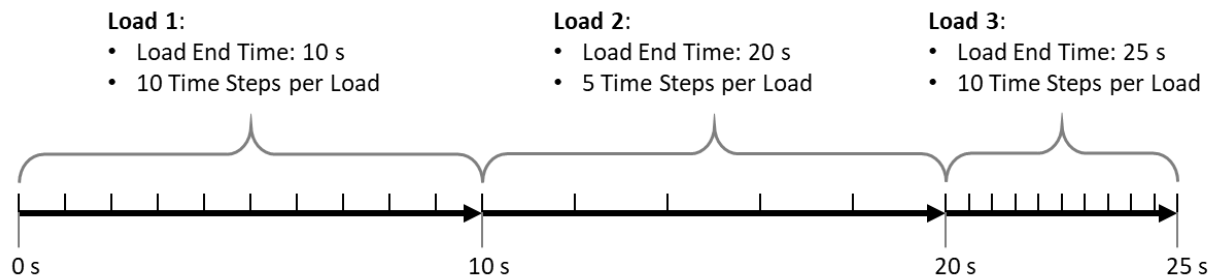

The load sequences can be combined as desired. The user can e.g., do a compression in X-direction followed by a compression in Y-direction and a shear load.

In the example below, the 3rd load is subdivided into 10 time steps (**Time Steps per Load**) and the load scenario is **Tensile**.

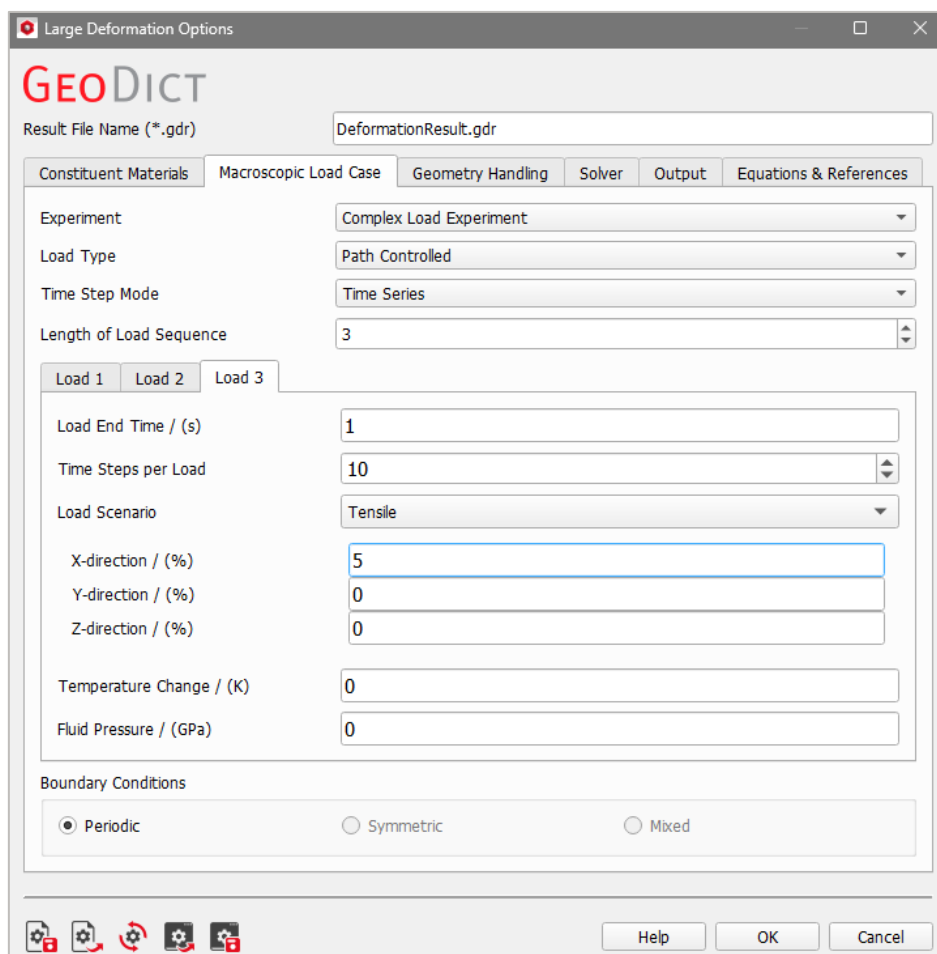

EXAMPLE: SETTINGS FOR UNIAXIAL COMPRESSION

In this example, we set a compression by 5 % along the z-axis. Choose **Uniaxial Experiment - Compression** as Experiment and **Path Controlled** as the Load Type (to prescribe the compression ratio).

Keep the default settings for **Load Case** to compress along the Z-axis. The tangential boundary condition should be chosen depending on the needs, here we set it to **Free** to allow expansion in tangential direction. The **Pressure Mode** is set to **No Pressure** as there is no fluid pressure applied.

Under **Predefined Shape**, choose **Linear**, set a **Magnitude** of 5 %, a **Length** of 5 s, and a **Number of Steps** of 5. Generally, the time and number of steps should be chosen depending on the user's needs. More steps always mean more computing

time. After the settings for the **Predefined Shape** are made, click **Apply** to update the **Load Table** to these values.

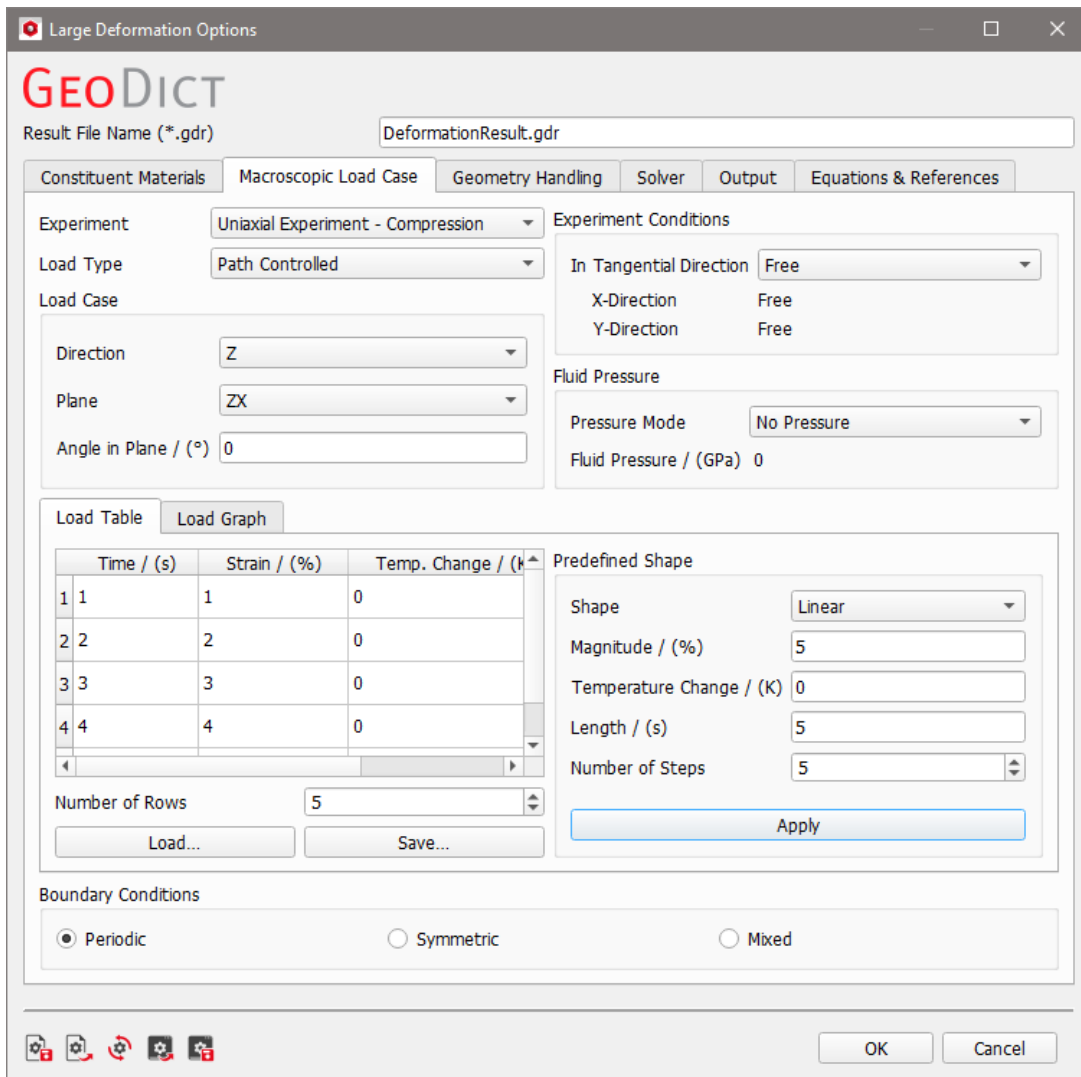

GEOMETRY HANDLING

The **Geometry Handling** tab contains all options related to geometry changes during the simulation.

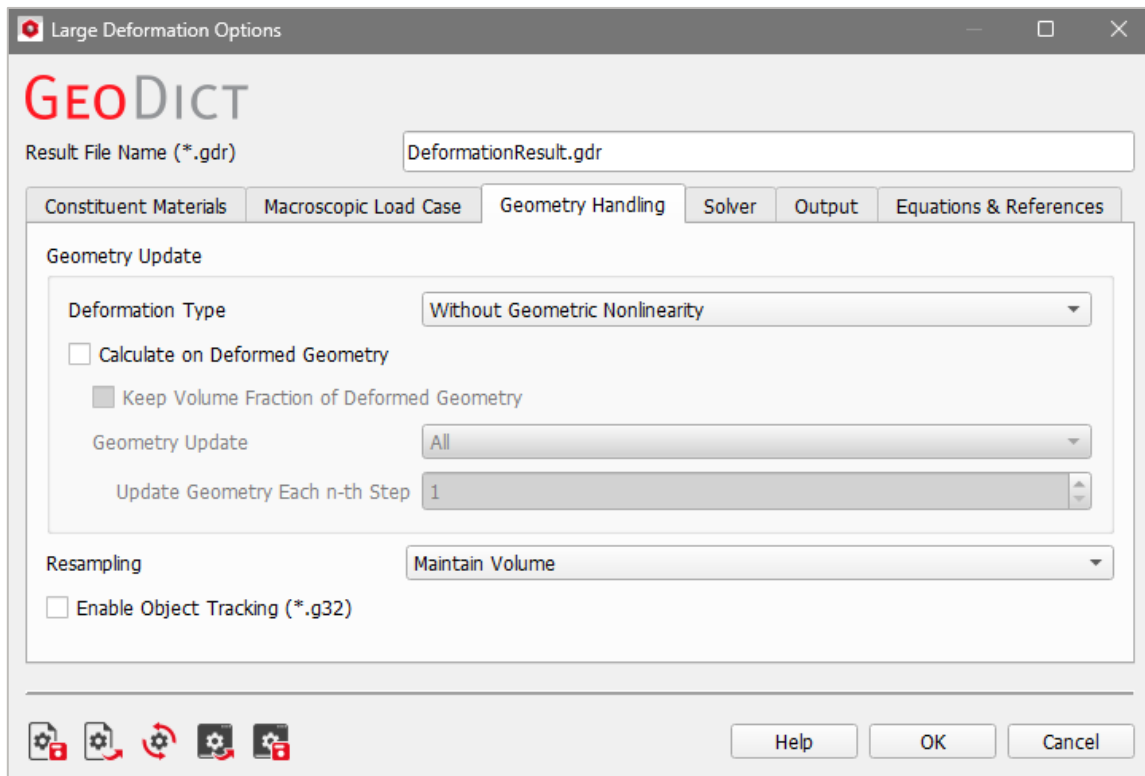

DEFORMATION TYPE

Under **Deformation Type**, the theory which is used for the structural mechanics is selected:

- **Without Geometric Nonlinearity:** This approach is faster and more reliable than the geometric nonlinear case. More material models are available in GeoDict for this case (e.g., Plasticity and Damage models). The boundary conditions for this experiment type are given as mean strains or mean stresses in the analyzed volume.
 - Here, the **infinitesimal strain theory** applies (see more information on [Wikipedia](#)). This is the linearized form of the *finite strain theory* (which applies to **With Geometric Nonlinearity**).
 - It is assumed that only small deformations occur, for example it is assumed that no rotations occur.
 - This is the simpler theory, but it is much more robust and easier to solve and is therefore preferable in most use cases. We recommend to always try **Without Geometric Nonlinearity** first.
 - For applications with larger deformations use **Without Geometric Nonlinearity** with **Calculate on Deformed Geometry** on (see page [24](#)).
 - The usual strain and stress definitions apply only here.
- **With Geometric Nonlinearity:** Should be used when the theory of small deformations does not hold anymore. A nonlinear problem must be solved; therefore, the computation might be considerably slower than for the geometric

linear case. The boundary conditions for this experiment type are given as mean displacement gradient or mean nominal stresses in the analyzed volume.

- Here, the **finite strain theory** applies (see more information on [Wikipedia](#))
- Here, large deformations are considered, this means that also the effect of rotations is considered correctly.
- This theory is more complete, but also *much more complicated to solve* (Finite Strain Theory).
- Here, many different definitions for the stresses and strain are possible. The usual strain and stress definitions do not apply here. Nevertheless, if the deformations are small, the strains in the nonlinear definitions do not deviate largely from the strains in the linear definition (e.g., for small strains, the Green Lagrange Strain is close to the Strain for **Without Geometric Nonlinearity**).

The difference between the geometric linear and nonlinear case is not special to **GeoDict**. This concerns all structural mechanics simulations – one always needs to choose between the simpler, but robust theory (**Without Geometric Nonlinearity**) and the more general theory (**With Geometric Nonlinearity**), which is much more complicated to solve and understand, but necessary in some cases. The two options (“With/Without Geometric Nonlinearity”) might have slightly different names in other software, but the theory behind them is the same.

CALCULATE ON DEFORMED GEOMETRY

With **Calculate on Deformed Geometry** checked, the deformed geometry is re-sampled, and this geometry is used for the calculations in the next step. With this method, it is possible to detect new object contacts during deformation and e.g., to observe the effect of stiffening during compression. **Calculate on Deformed Geometry** can only be used without geometric nonlinearity.

A resampling step is done if the conditions defined under Geometry Update are met. It is important to choose these settings appropriately for the current geometry and deformation steps: With each resampling step, discretization errors occur, and these errors accumulate if too many resampling steps are done. Therefore, the resampling should only be done after a significant change in the geometry size. This can be achieved by choosing the mode **Size Control** for **Geometry Update** (see page [25](#)).

- **Off:** The deformation is always calculated relatively to the original geometry

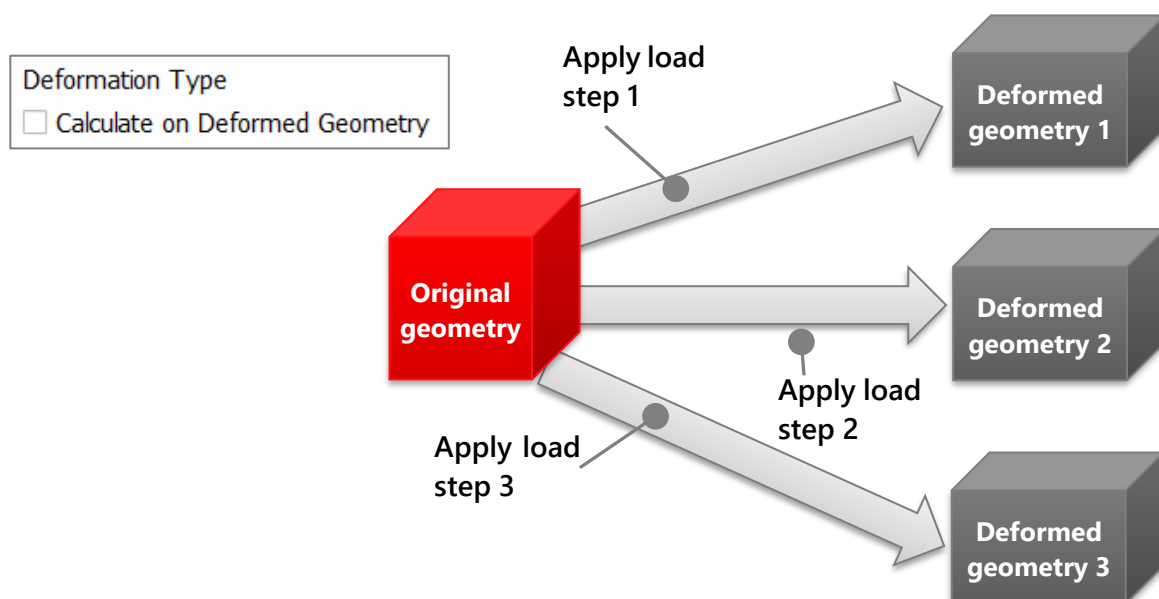

■ On:

If the conditions defined under **Geometry Update** are met, the deformed geometry is calculated, and the deformation is calculated relative to the previous geometry. In the figure below, the behavior of the setting **All** for **Geometry Update** is shown.

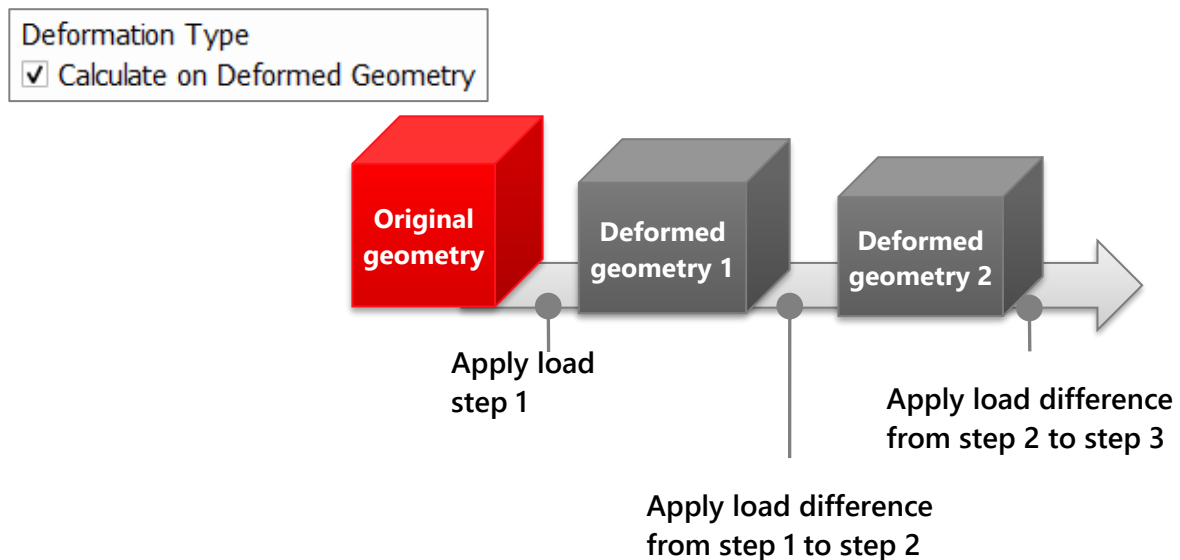

KEEP VOLUME FRACTION OF DEFORMED GEOMETRY

If **Keep Volume Fraction of Deformed Geometry** is checked, the accurate volume fraction information for each material ID after the deformation is kept and updated in memory. Refer to page [26](#) for further information about the volume fractions. This needs more memory but leads to a more accurate geometry deformation if many (small steps) are computed. Without this information, the volume fractions are converted into a structure in each deformation step and the volume fraction gets lost.

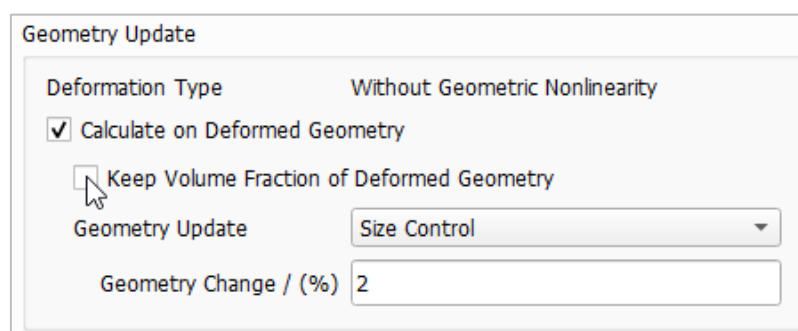

GEOMETRY UPDATE

Under **Geometry Update**, it can be selected when the next simulation step is computed on the newly deformed geometry, or if it is computed based on the existing geometry.

Use the mode **Size Control** for the Geometry Update when using **Calculate on Deformed Geometry**. With this mode, the size of the deformation is checked after each step.

Only if the deformation is larger than the given threshold, **Calculate on Deformed Geometry** is used for this step. Otherwise, the step is done without **Calculate on**

Deformed Geometry. We strongly recommend using this mode for simulations of this type.

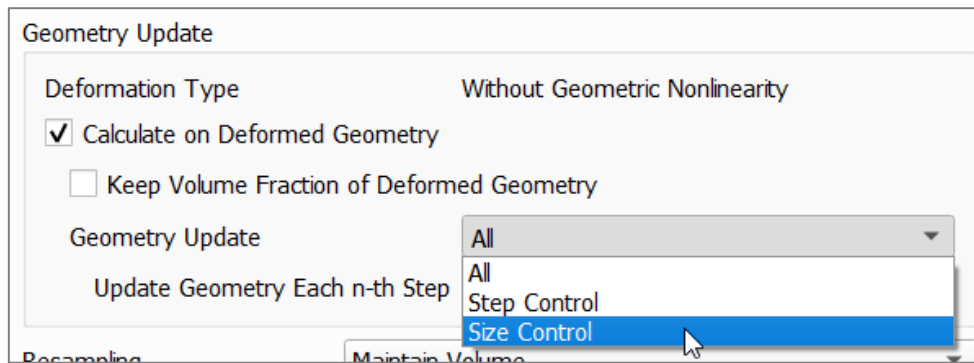

- **All** – The geometry is updated in every step

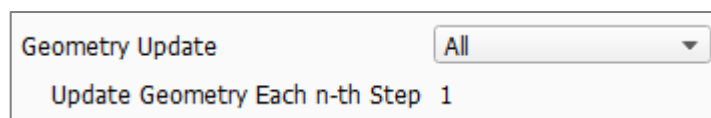

- **Step Control** – Choose how often the geometry is updated with **Update Geometry Each n-th Step**.

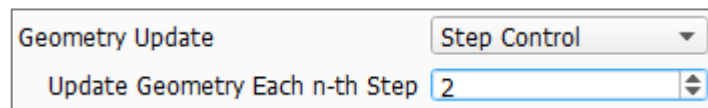

- **Size Control** – If the geometry is updated or does not depend on the change of the domain size. If the size change for one domain side is larger than the value defined for **Geometry Change / %**, the geometry is updated.



RESAMPLING

For **Resampling**, two options can be chosen: **Maintain Volume** or **Maintain Mass**. Deformation in **ElastoDict** is computed and stored as a displacement field. For each voxel, this displacement field contains the information on how far it is displaced in the current deformation step.

Internally, the new material positions are calculated based on this displacement information. Since the new positions do not necessarily lie on the voxel grid, a gray value image with material **Volume Fractions** is computed for each material ID. These volume fractions contain the information “how much” of a given material is contained in a voxel after the deformation. These volume fractions must be resampled to the voxel geometry. In the figures below, this resampling is shown in a simplified example for one material ID. The deformed geometry is generated by thresholding the resulting gray value image containing the volume fractions.

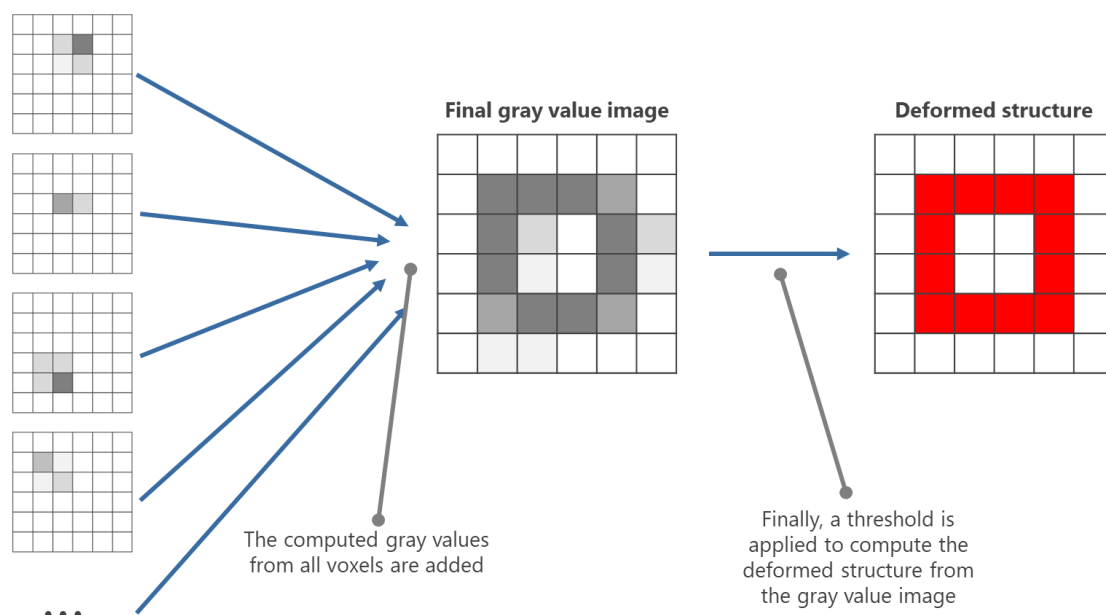
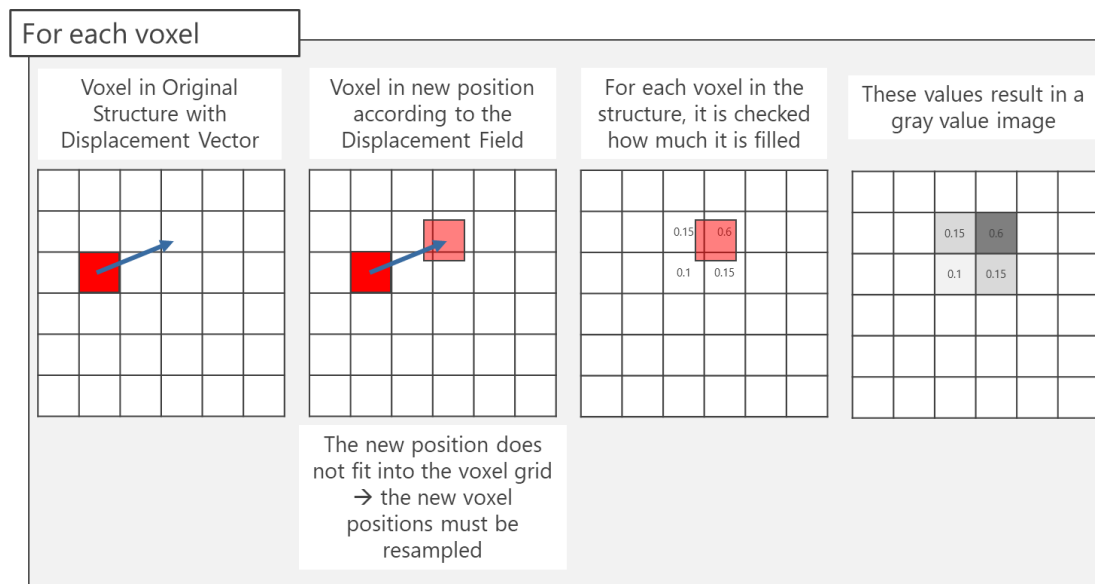

With **Maintain Volume**, the resampling threshold is chosen in such a way that the volume of each solid material in the structure stays roughly the same. With **Maintain Mass**, the threshold for each voxel is set to 0.5. This means, **Maintain Volume** is a good choice when it is expected that the volume of a material does not change during the deformation. When deformations occur where the volume of the material changes significantly during the computations, e.g., thermal expansion or expansion due to a negative Poisson's ratio, **Maintain Mass** should be used.

ENABLE OBJECT TRACKING (*.g32)

With the object tracking option, a *.g32 file with the object indices for all objects in the structure is created for each deformed geometry. This way, the deformation of each object in the structure can be tracked during the deformation.

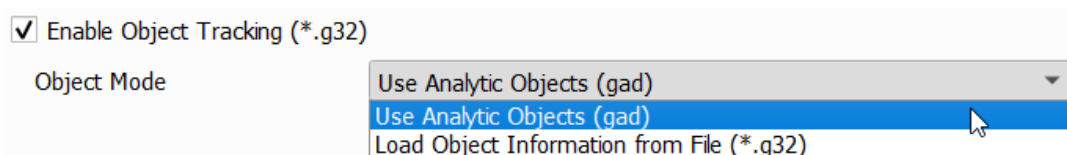

OBJECT MODE

The choice for **Object Mode** depends on the available information: If a structure with analytic object information (e.g. from **GeoDict**'s structure generator modules **FiberGeo**, **GrainGeo**, **FoamGeo**, ...) is used, this information can be used with **Use Analytic Objects (gad)**. In this case, a *.g32 file with object indices is automatically created and saved in the results folder. If no analytic object information is available, **Load Object Information from File (*.g32)** must be selected and a *.g32 file must be loaded. A *.g32 file can be created e.g. with **GrainFind** for all grains in the structure.

In the example below, a weave structure from **WeaveGeo** with the corresponding object indices is shown before and after deformation in **ElastoDict**. These structures can be loaded directly from the result viewer with the corresponding buttons (shown below).

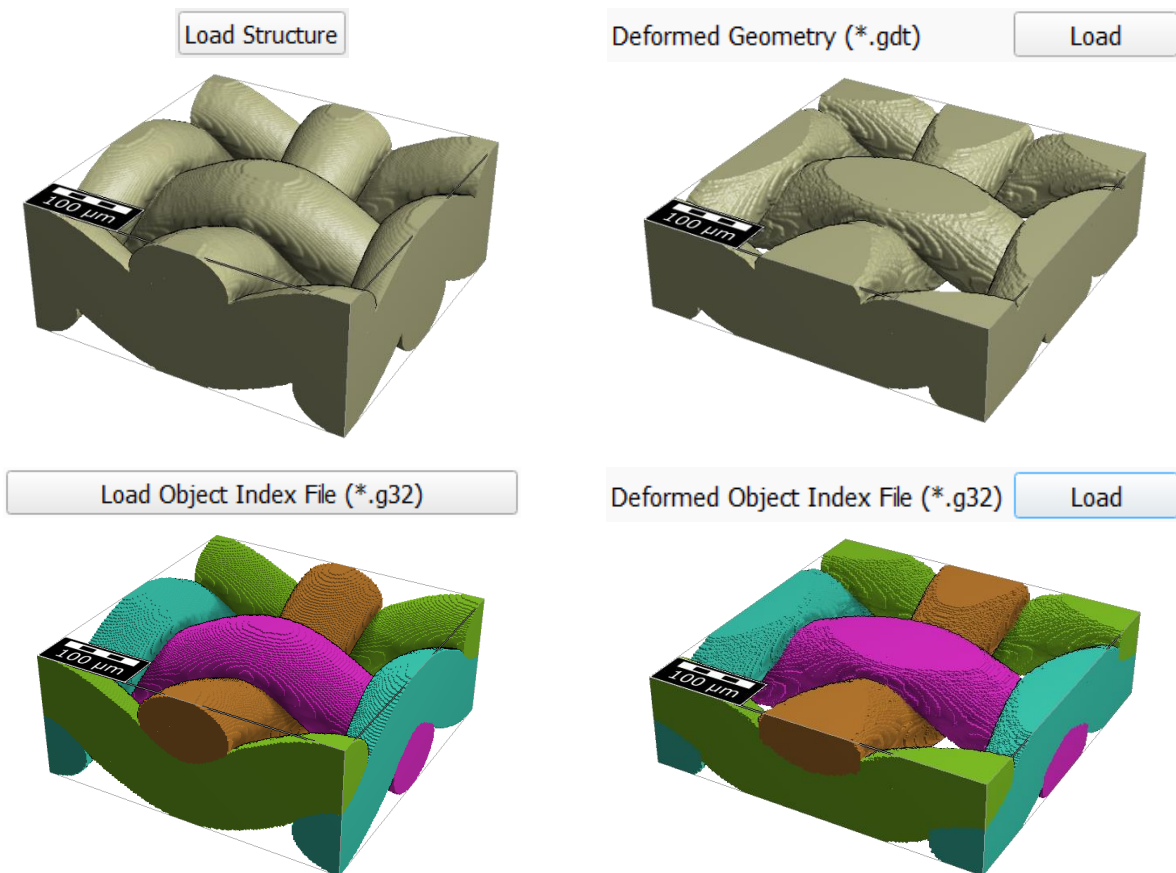

SOLVER

Internally **ElastoDict** uses an iterative solver to solve the equations that describe the mechanical problem at each voxel. The basic idea of an iterative method is:

1. Start with an initial guess for the unknown values.
2. Improve the current values in each iterative step. The speed of the improvement depends on the problem parameters.
3. Repeat the iterative process until one of the stopping criteria occurs.

SIMULATION STOPPING CRITERION

The iterative process of the solver is controlled by setting the values for **Tolerance**, **Maximal Iterations**, and **Maximal Run Time (h)**. Only the tolerance must be set, the two other parameters are optional.

For each iteration step, the relative error of the current solution is computed. If this relative error is smaller than the given tolerance, the computation is finished. When there is doubt about the quality of the solution, decrease the tolerance value by a factor of ten for that solver. In general, it is recommended to keep the default setting for tolerance.

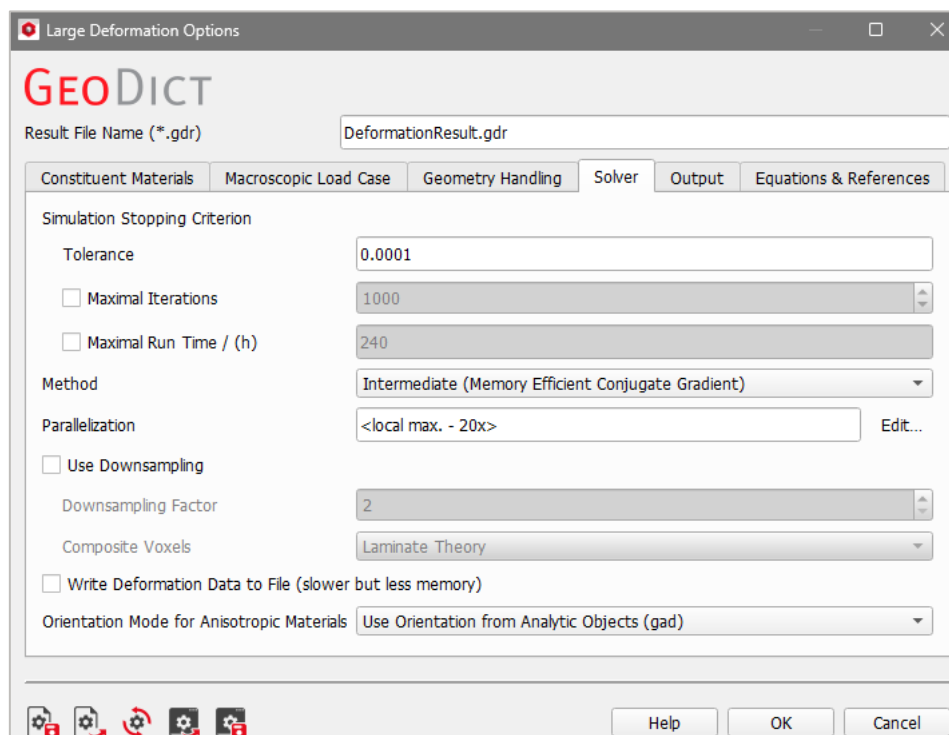

When the solver stops because the **Maximal Iterations** or the **Maximal Run Time (h)** are reached, the quality of solution might be doubtful since the requested accuracy is not achieved. Therefore, those two options are disabled by default and should only be selected if there are strong constraints on the allowed runtime.

METHOD

For the **FeelMath** solver, three different iterative methods are available: **Fast (Conjugate Gradient)**, **Intermediate (Memory Efficient Conjugate Gradient)** and **Memory Efficient (Neumann Series)**.

The **Fast** method converges faster, especially for strongly varying material parameters and nonlinear material laws (as e.g. plasticity or damage), but needs about four times as much memory as the **Memory Efficient** method.

The **Intermediate Method** needs approximately 40 % less memory than the **Fast** method but is 20-30 % slower. The **Estimate memory** button, in the **ElastoDict** section (see page 7), can be used to decide which method is applicable for the current structure on the available computer.

In general, it is recommended to use the default (**Memory Efficient Conjugate Gradient**) or the **Conjugate Gradient** method. The **Neumann Series** method should only be used if the memory is not enough for the other methods.

PARALLELIZATION

The **ElastoDict** run can be accelerated by using multiple CPU cores. The **Parallelization Options** dialog opens when clicking the **Edit...** button, to choose between **Local Sequential**, **Local Parallel**, **Local Maximum** and **Cluster**. On Linux, **Local MPI Parallel** is additionally available.

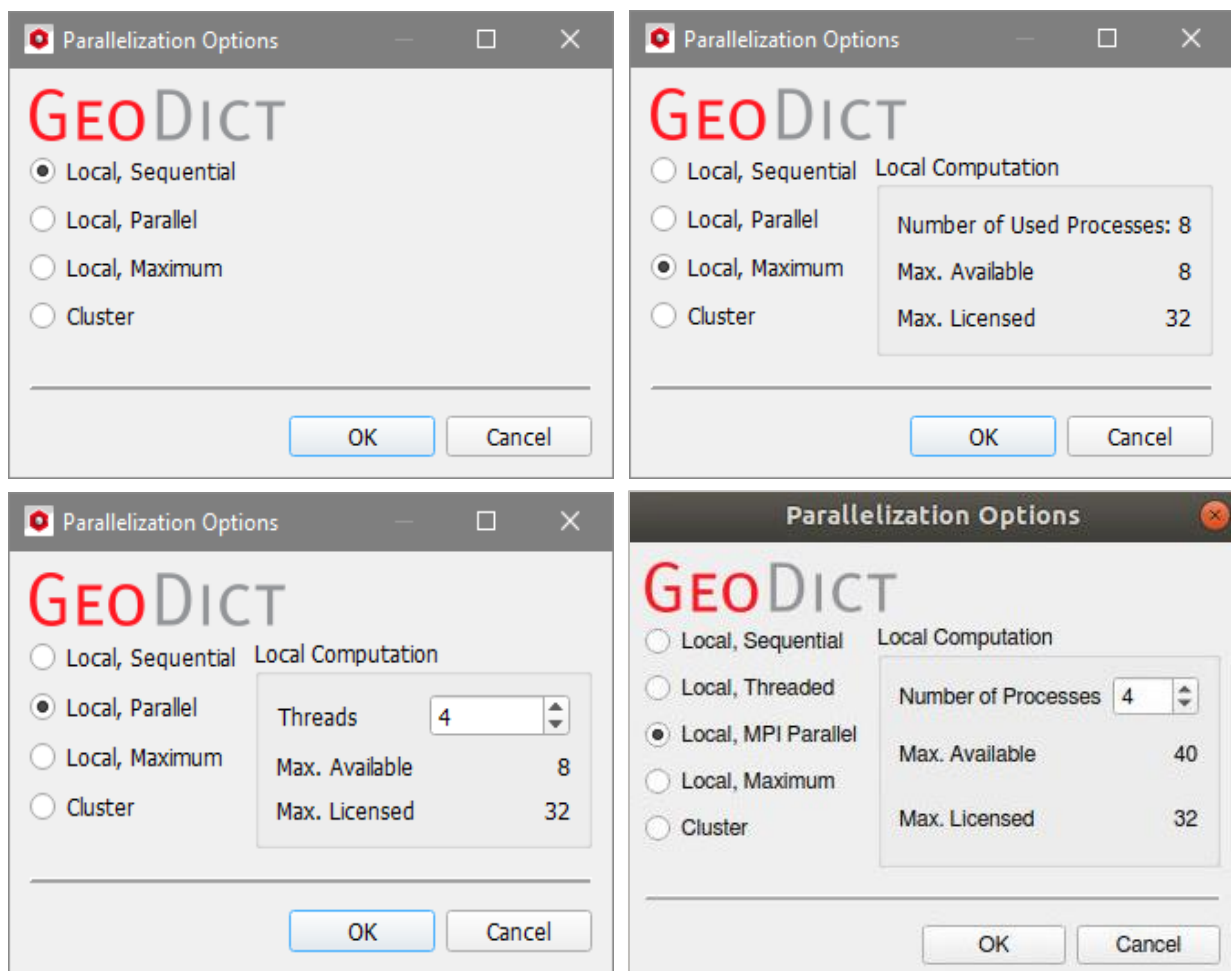

The number of **Threads** to run can be entered after choosing **Local Parallel**. **Local, Maximum** is the default and provides the fastest possible computation based on the available and licensed processes. With **Local, Sequential**, only one thread is used, and no parallel computation is done.

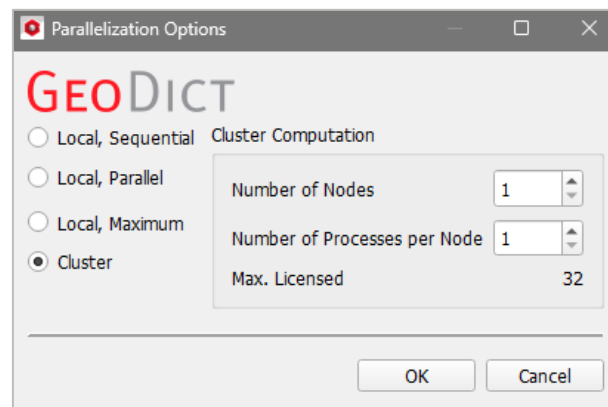

For information on how to set up the **Number of Nodes** and **Processes per Node** to use **ElastoDict** in a **Cluster** configuration, contact **Math2Market** support.

USE DOWNSAMPLING

Downsampling reduces the structure size by combining multiple voxels. By default, the **Downsampling Factor** is set to two – this means that 2x2x2 voxels are combined to one voxel. The material model used for each voxel in the downsampled structure is a combination of the material model (e.g., a **Composite Voxel**) of the original voxels. Since the simulated structure size is much smaller than the original structure, **Downsampling** allows to speed up the simulation and to quickly obtain results even on computers with little memory. This option should not be used if highest accuracy is required.

In most cases, a **Downsampling Factor** of 2 is the best choice, but it can also be set to 4 if needed. Then, the computation will be faster, but the results could be more inaccurate.

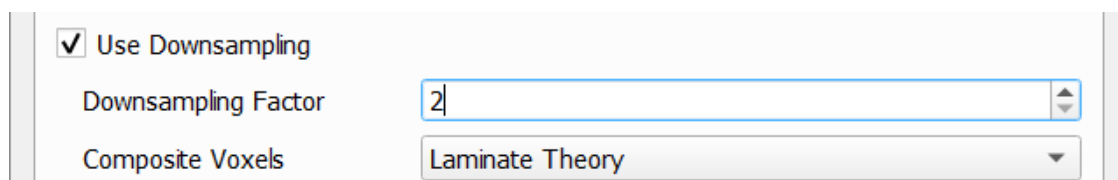

To be able to use downsampling, the features (e.g., fibers or grains) in each material ID must have a diameter of at least the Downsampling factor in voxels (e.g., 2 voxels for a **Downsampling Factor** of 2). Otherwise, the computation of the material properties might not work properly. Since **GeoDict 2021**, an error message is shown if all features in the structure are smaller than this diameter, and the simulation cannot be started.

COMPOSITE VOXELS

Two different methods to compute the **Composite Voxels: Laminate Theory** (the default), and **Arithmetic Mean**. When using **Laminate Theory**, the composite material properties are computed based on the laminate theory of composite materials. With this option, also direction dependent properties are represented correctly. With **Arithmetic Mean**, the material properties of the composite voxel are the average of the material properties of the original voxels. This method is less accurate, but the simulation might be more stable, especially if the structure contains many pores (as e.g., in foams). Nevertheless, it is recommended to keep the default **Laminate Theory** in most use cases for the higher accuracy.

WRITE DEFORMATION DATA TO FILE

For the computation of the deformed structures, intermediate data is computed which describes the displacement for each voxel. Before this computation, it is not clear how large this data will be, since a voxel in the original structure might be partially moved in multiple voxels in the deformed structure. Therefore, this data might not fit in the main memory of the computer. Due to this, the deformation data was always written to the hard drive in **GeoDict 2020** and before. Nevertheless, there is an issue with this approach: Writing and loading data from the hard drive is many times slower than writing and loading data in the main memory (even if the drive is an SSD). This causes a bottleneck, which can slow the simulation down.

Therefore, **GeoDict 2021** and later allows to keep the deformation data in memory. This is the new default, since the data fits in the main memory in most cases, and this option is many times faster (See benchmark results on page [50f.](#)). To get the old behavior from **GeoDict 2020** and before, check the option **Write Deformation Data to File**. We recommend keeping this option disabled, and to select it only if the simulation fails because the data doesn't fit in the RAM.

ORIENTATION MODE

ElastoDict can handle non-isotropic constituent materials. For these materials, an orientation has to be additionally specified. If the analyzed structure consists of analytical objects (gad data), the orientation of these objects is used when **Use Orientation from Analytic Objects (gad)** is selected.

Alternatively, with **Load Orientation Information from File (*.gof)**, orientation information can be loaded from a file. Such a file can be generated for example with GrainFind for granular structures. The third option, **Use the Global XYZ-Coordinate System**, allows to use anisotropic materials even if no orientation information for the structure is available.

The image shows three sequential screenshots of the 'Orientation Mode' dropdown menu in the software interface. The first screenshot shows the menu with 'Use Orientation from Analytic Objects (gad)' selected. The second screenshot shows the menu with 'Load Orientation Information from File (*.gof)' selected, and below it, a text input field for 'Orientation File Name (*.gof)' with a 'Browse...' button. The third screenshot shows the menu with 'Use the Global XYZ-Coordinate System' selected.

OUTPUT

The options available in the Output tab control which information is saved to the hard disk during the computation. Choosing only the necessary variables might help to save computation time.

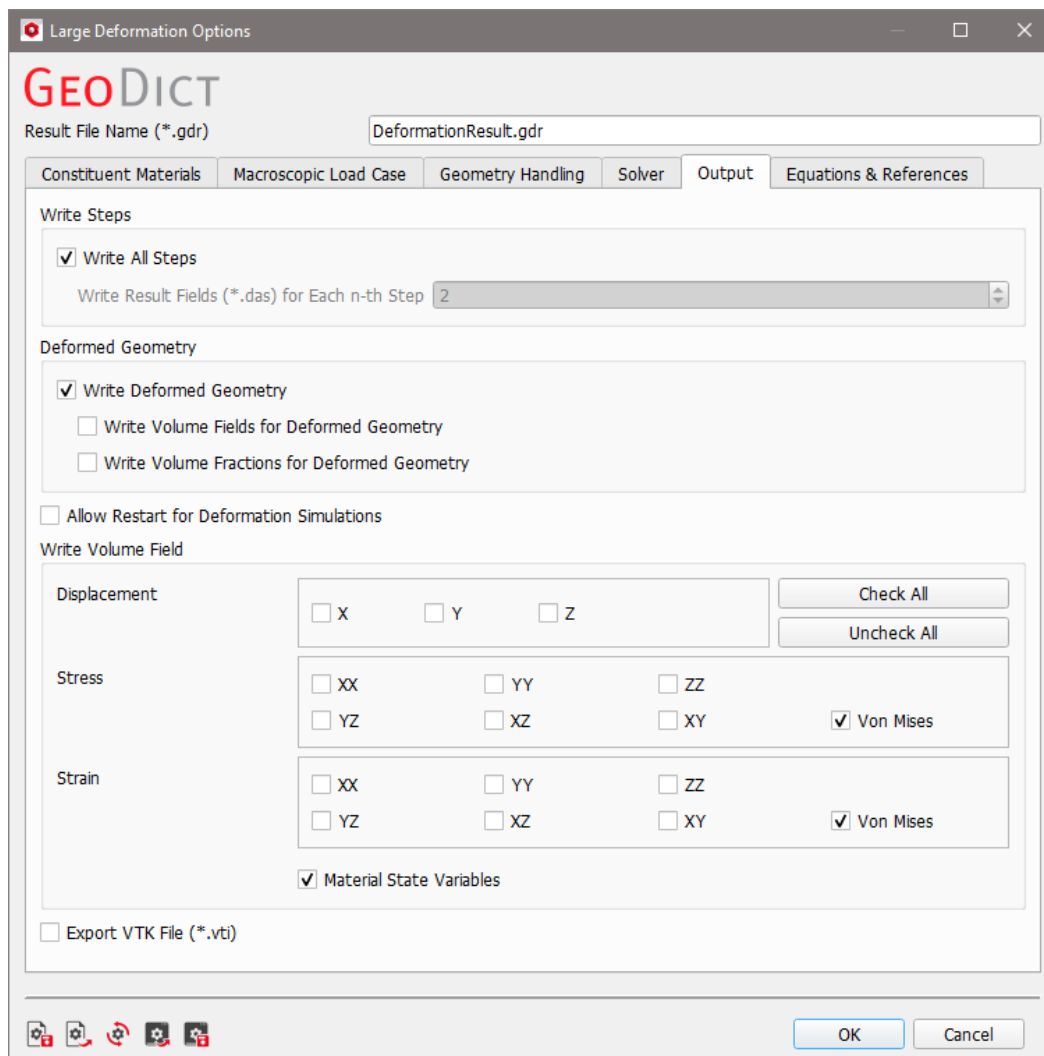

WRITE ALL STEPS

When **Write all Steps** is chosen, the results fields selected under **Write Volume Field** are written after each computation step. Otherwise, the number of steps after which the results fields are saved can be selected. When computing with many steps, disabling **Write all Steps** saves considerable computation time.

DEFORMED GEOMETRY

When **Write Deformed Geometry** is chosen, a geometry with the current displacements is resampled and saved after each step. Deformed geometries are written at each step, even if **Write all Steps** is disabled. Writing the deformed geometries is mainly interesting for visualization purposes and to check possible problems in the simulation setup when **Calculate on Deformed Geometry** is chosen in the [Geometry Handling](#) tab.

With **Write Volume Fields on Deformed Geometry**, also the result fields are resampled with the current displacements so that they match the deformed geometries.

With **Write Volume Fractions for Deformed Geometry**, the volume fractions for each material ID in each voxel after the deformation are written to the *.das files. This information is necessary for the computation of the deformed geometries (For further understanding, check out the explanations on page [26](#)). In general, it is not necessary to select this option.

Depending on which options have been chosen in the **Geometry Handling** tab, some **Deformed Geometry** options might be checked unchangeable for the user. In this case, the tick is visualized in green. For example, if **Calculate on Deformed Geometry** and **Enable Object Tracking (*.g32)** is chosen, **Write Volume Fields for Deformed Geometry** is selected by default and can't be deselected by the user.

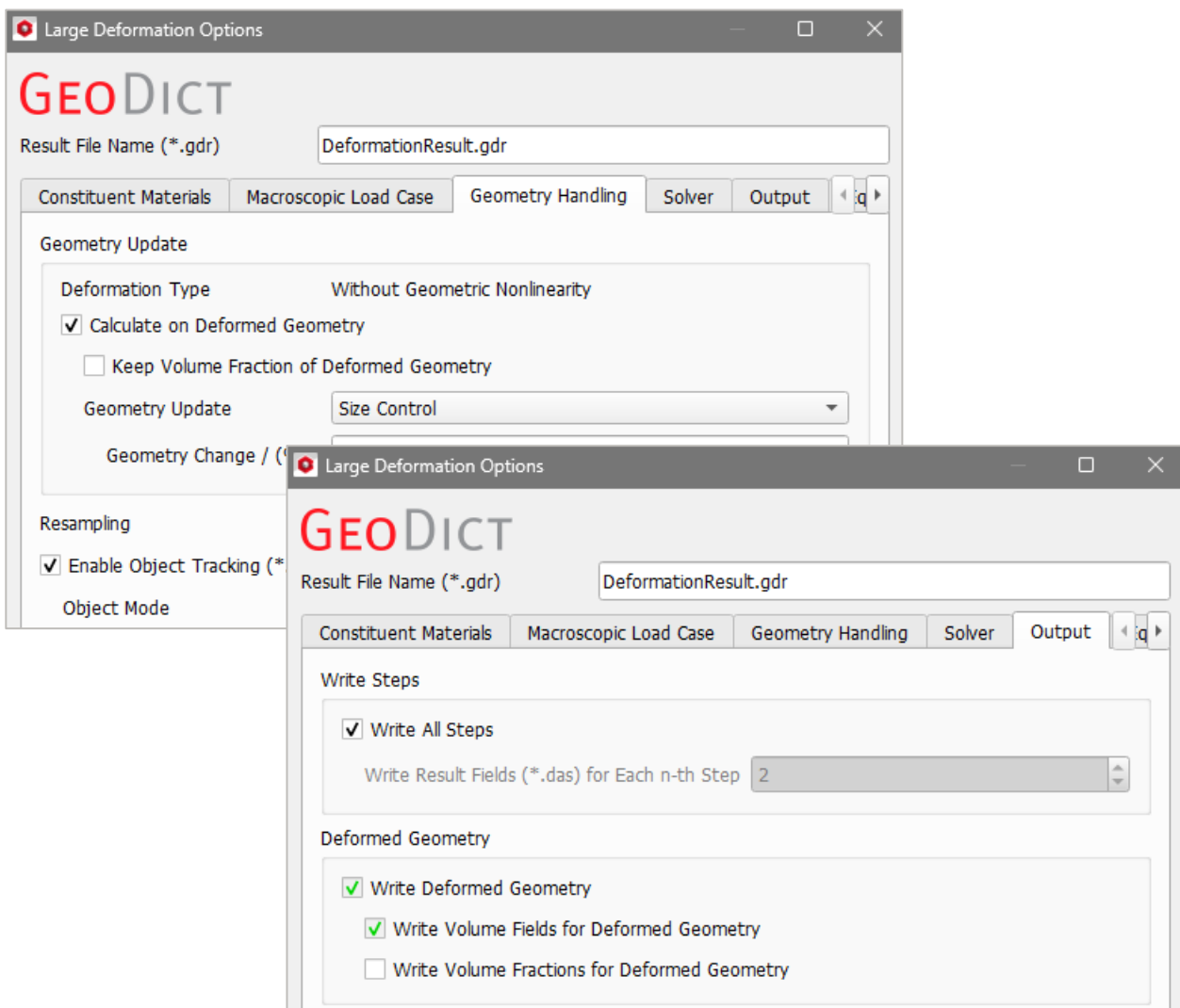

ALLOW RESTART FOR DEFORMATION SIMULATIONS

If you want to be able to restart a simulation after an interruption, the complete stress and strain information must be saved for each step. With the option **Allow Restart for Deformation Simulations**, the necessary volume fields are automatically checked under **Write Volume Field** below and therefore saved.

Since GeoDict 2022, restarting is also available for simulations with **On Deformed Geometry**.

WRITE VOLUME FIELD

Checking or un-checking the boxes for **Displacement**, **Stress**, and **Strain** determines whether these results outputs are available for visualization and post-processing after the run of the **ElastoDict-Deformations**. Additionally, it is possible to save the deformed geometry and to save the solution fields (for stress and strain) for the deformed geometry. Depending on the structures size, the result files can become large (up to several GB), so it is recommended to deselect all options which are not needed for the current task.

For nonlinear materials, additional state variables might be defined. For example, for plastic deformation, these are the elastic and plastic strains. For materials with damage behavior, this is the damage variable. When **Material State Variables** is checked, these variables are saved as volume fields.

EXPORT VTK FILE

Besides using GeoDict's own visualization tools, it is possible to export the solution in the commonly used VTK (Visualization Toolkit) format (see: <https://vtk.org/> and, <https://www.paraview.org/>).

EQUATIONS & REFERENCES

The differential equations solved in the simulation are listed under the **Equations & References**. Additionally, the tab contains the references for the methods used by the FeelMath solver in **ElastoDict** (see page [1](#) for links and general information).

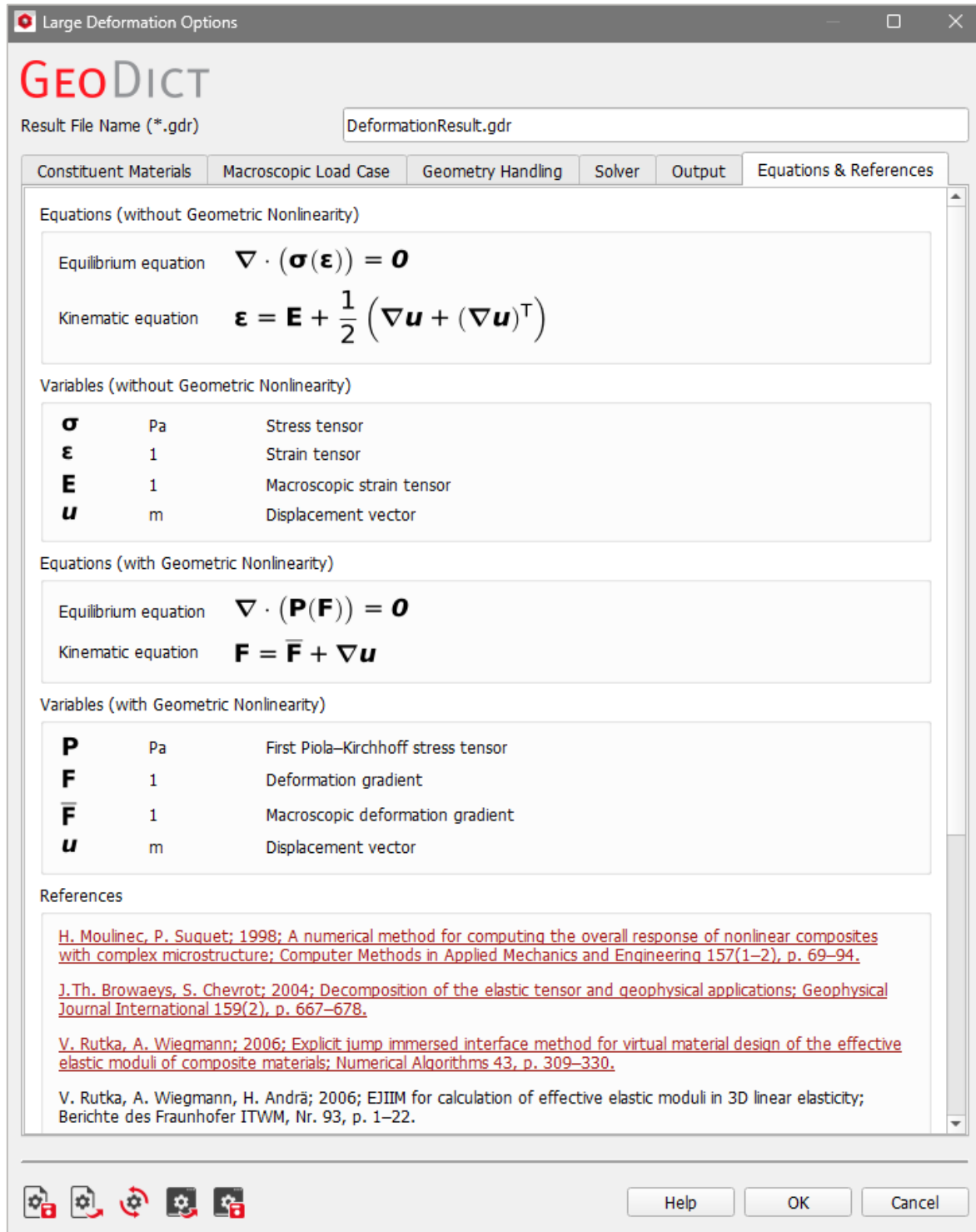

RESULT FILE (.GDR)

After the solver has finished, the result file (.gdr) is saved in the project folder and the Result Viewer opens automatically.

In the **Result Viewer**, the list of all open result files and the path to them is shown in the header section. Results from older runs are accessible by opening their *.gdr files (**File** → **Open *.gdr File...** in the menu bar). The name of the result file currently displayed is highlighted in blue in the header section. Multiple results files can be opened at the same time. To compare their results, use **CTRL+right-click** to select multiple results files in the Result Viewer. The selected result files are shown side-by-side.

The header section and the post-processing section (left panel of the **Results** tab) can be collapsed (and expanded) by pulling up/down or left/right on the dotted line.

The green dot in the right side of the Result Viewer indicates that the results shown are computed for the structure displayed in the visualization area (in memory) at this time. The dot is red when the structure in memory is not the one for which the values in the opened result file were calculated. The corresponding structure can be loaded by clicking **Load Structure** in the Result Viewer.

When two result files have green dots, it indicates that both result files correspond to the structure shown in the **Visualization area** and might be the results from two simulations with different **ElastoDict** settings. It is also possible to **Combine Results** files. For further information, refer to the [Result Viewer](#) handbook of the User Guide.

File

File	Module	Command
1 ...toDict2024/ExtraFiles/Elastodict2024/DeformationResult.gdr	ElastoDict	SolveDeformations

Up Down Swap Selected Synchronize Tabs

Combine Results Raise Main Window

Do Mrz 21 2024 (2024 Build 71670) Domain Size: 200 x 200 x 200 Voxel Length: 1 µm Load Structure

Input Map Log Map Post Map Results Strain/Stress Visualization Create Videos Metadata

Strain Definition: Average Strain Stress Definition: Nominal Load Sign Definition: Tension is Positive Report Stress Unit: GPa Report Strain Unit: % X-Axis: Strain Z-Dir Y-Axis: Stress Z-Dir Apply... Back-up result file

Report Plots Map

Coordinate system
The coordinate system of the experiment is aligned with the coordinate axis in GeoDict.

Average strain

Time / (s)	Temp. Change / (°C)	XX / (%)	YY / (%)	ZZ / (%)	YZ / (%)	XZ / (%)	XY / (%)	VonMises / (%)	Hydrostatic / (%)
0	0	0	0	0	0	0	0	0	0
1	0	-0.72016	-0.68431	2	-0.028204	0.03174	-0.017461	2.70358	0.198509
2	0	-1.4405	-1.3694	4	-0.05681	0.064107	-0.034613	5.40762	0.396731
3	0	-2.1602	-2.054	6	-0.085649	0.096757	-0.051734	8.11119	0.595276
4	0	-2.8804	-2.739	8	-0.11455	0.12951	-0.06873	10.8152	0.793526
5	0	-3.6003	-3.4237	10	-0.14349	0.16233	-0.085802	13.5189	0.992005

Average stress

Time / (s)	Temp. Change / (°C)	XX / (GPa)	YY / (GPa)	ZZ / (GPa)	YZ / (GPa)	XZ / (GPa)	XY / (GPa)	VonMises / (GPa)	Hydrostatic / (GPa)
0	0	0	0	0	0	0	0	0	0
1	0	1.7287e-05	3.8263e-05	0.092525	5.8641e-06	-1.0071e-05	-1.0365e-05	0.0924974	0.0308602
2	0	-2.4247e-05	-3.5952e-06	0.18497	1.1866e-05	-1.4721e-05	-1.045e-06	0.184987	0.0616484
3	0	1.1603e-05	2.5796e-05	0.27747	7.9435e-06	-1.2163e-05	-1.0448e-05	0.27745	0.0925019
4	0	-1.606e-05	-6.0597e-06	0.36995	9.0828e-06	-1.3736e-05	-1.2069e-06	0.369957	0.123308
5	0	5.4725e-06	9.5366e-06	0.46244	6.6072e-06	-8.4339e-06	-6.5437e-06	0.462433	0.154152

Plot Options

Manage Data Load Input Parameters Export Close

The Result Viewer contains seven main tabs and subtabs:

- **Input Map** - all input parameters
- **Log Map** - solver specific values
- **Post Map** - parameters of the current plot
- **Results** - numerical results and plots
 - **Report**
 - **Plots**
 - **Map**
- **Strain/Stress Visualization** - 3D data which can be loaded in **GeoDict** for visual inspection
- **Create Videos**
- **Metadata** - description and user defined parameters

At the bottom of the Result Viewer, several buttons are available:

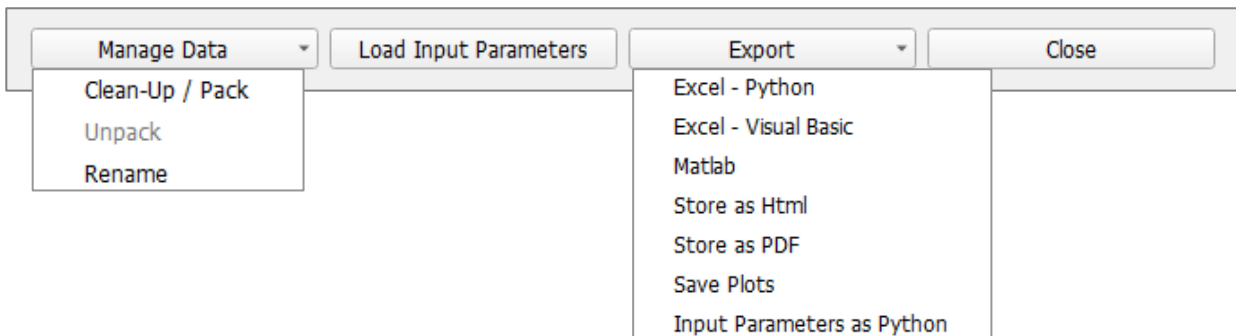

- Use the Manage Data option to **Clean-Up, Pack, Unpack** or **Rename** the result files. For the packing and unpacking operations, the additional software 7-zip is needed which can be installed with the **GeoDict** Required Tools installer.
- Load the solver options that were used for the calculations into the **ElastoDict** GUI by clicking **Load Input Map**.
- **Export** data:
 - Analyze and plot computation results in Microsoft Excel® using **GeoDexcel** provided with **GeoDict** by clicking **Excel – Visual Basic**. The generic import loads all information from the *.gdr file. **GeoDexcel** is only available for Windows®. See the [GeoDexcel](#) handbook of the **GeoDict** User Guide for more information. **Excel – Python** provides the same functionality as **Excel – Visual Basic** using Python and works on Windows and Linux.
 - Analyze computation results in MATLAB® using **GeoDict**'s MATLAB® interface **GeoLab** by clicking **Matlab**. All information included in the results file is loaded into MATLAB® automatically.
 - Save the information in the result file in *.html or *.pdf format by clicking **Store as HTML** or **Store as PDF**.
 - **Save Plots** to save images for all plots in the current results file
- Close the results file by clicking **Close**.

INPUT MAP

The **Input Map** contains all parameters which were used for the simulation. With the option **Load Input Map** at the bottom of the Result Viewer, all parameters are loaded into the **GeoDict** GUI and a new simulation with the same parameters can be started.

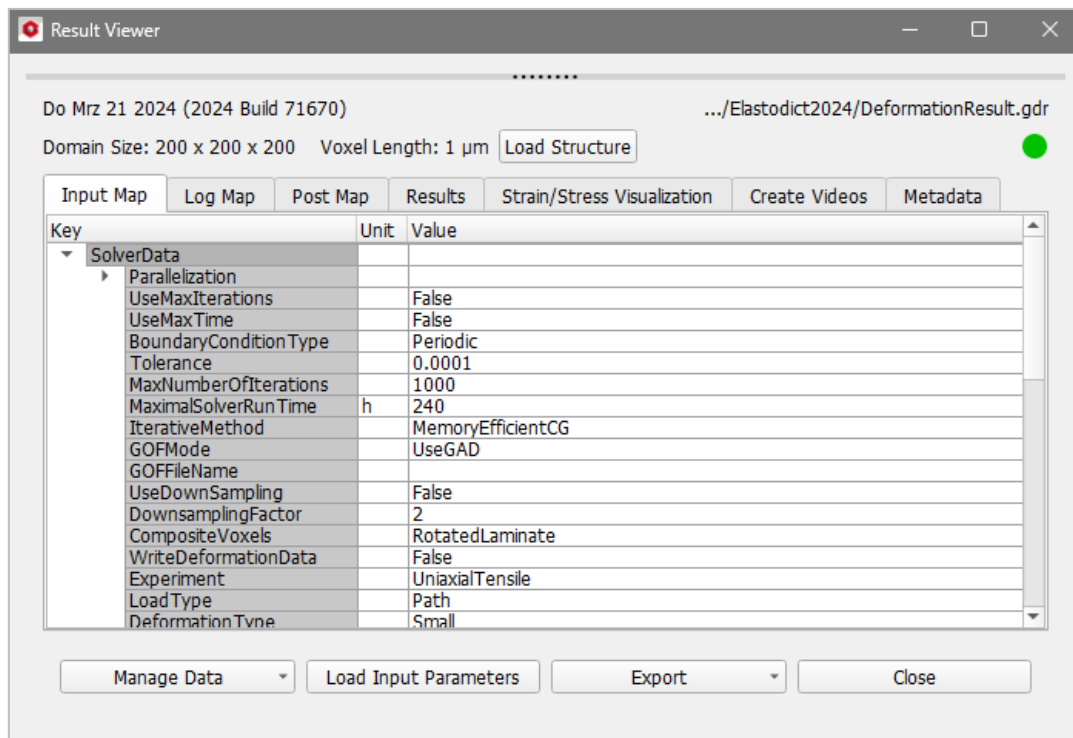

LOG MAP

The **Log Map** contains detailed information about the runtime and memory consumption during the simulation.

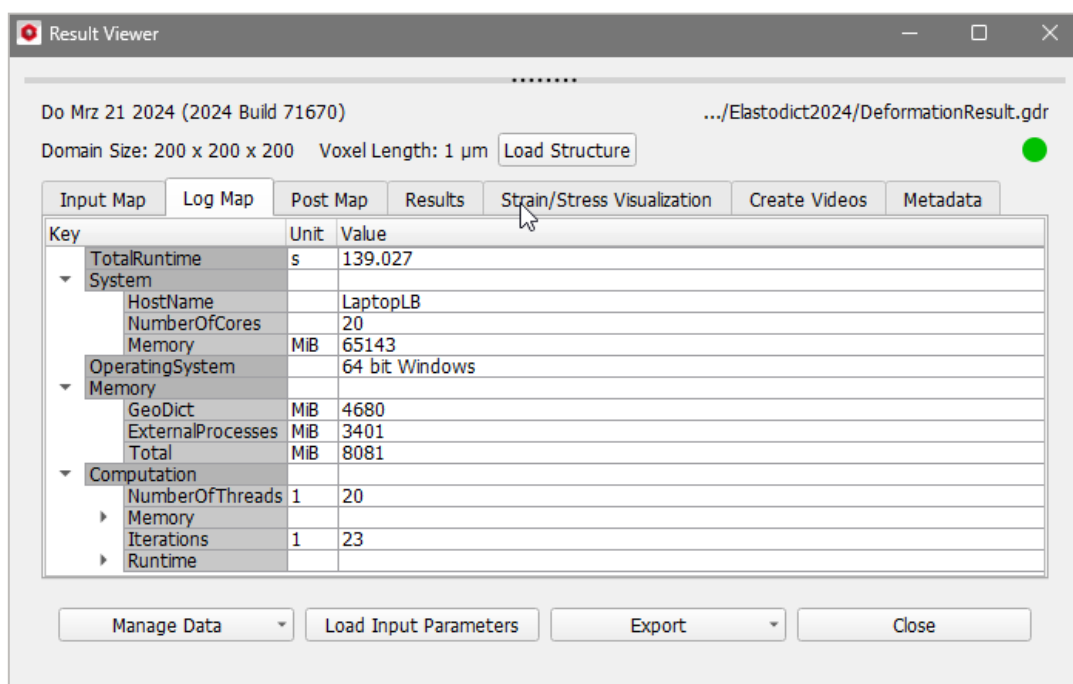

POST MAP

The **Post Map** tab contains all information on the current plot under the Results tab.

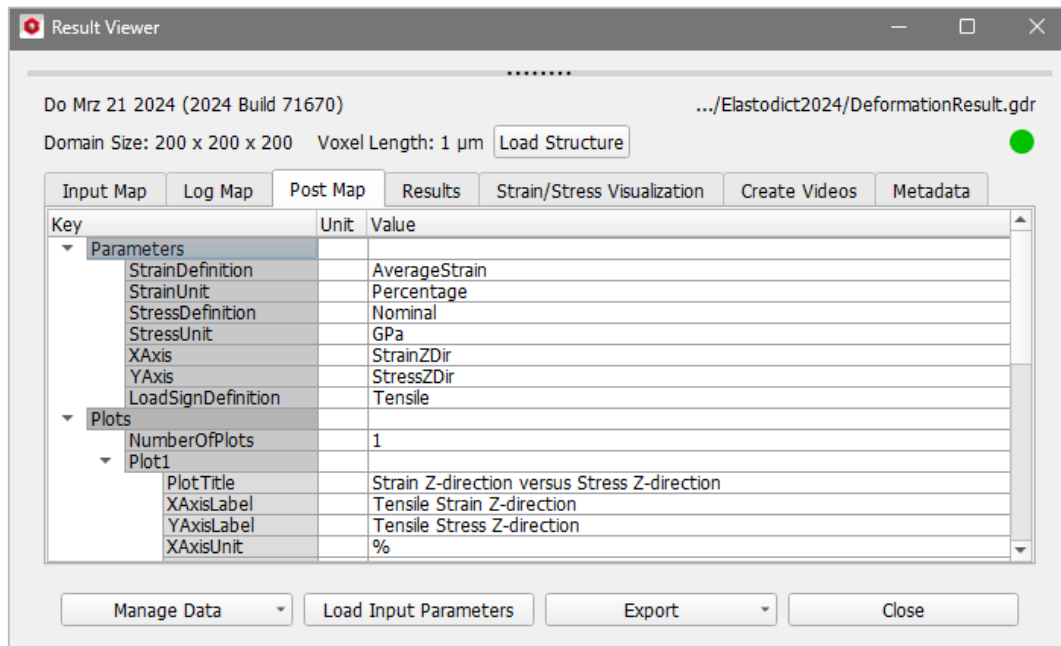

RESULTS

The **Results** tab gives access to the computed values for the parameters calculated by the selected **ElastoDict** process. The **Results** tab is divided into two or into three subtabs:

- The **Report** subtab shows the **Average Strain** (displacement gradient when using geometric nonlinearity) and **Average Stress** values in the experiment.

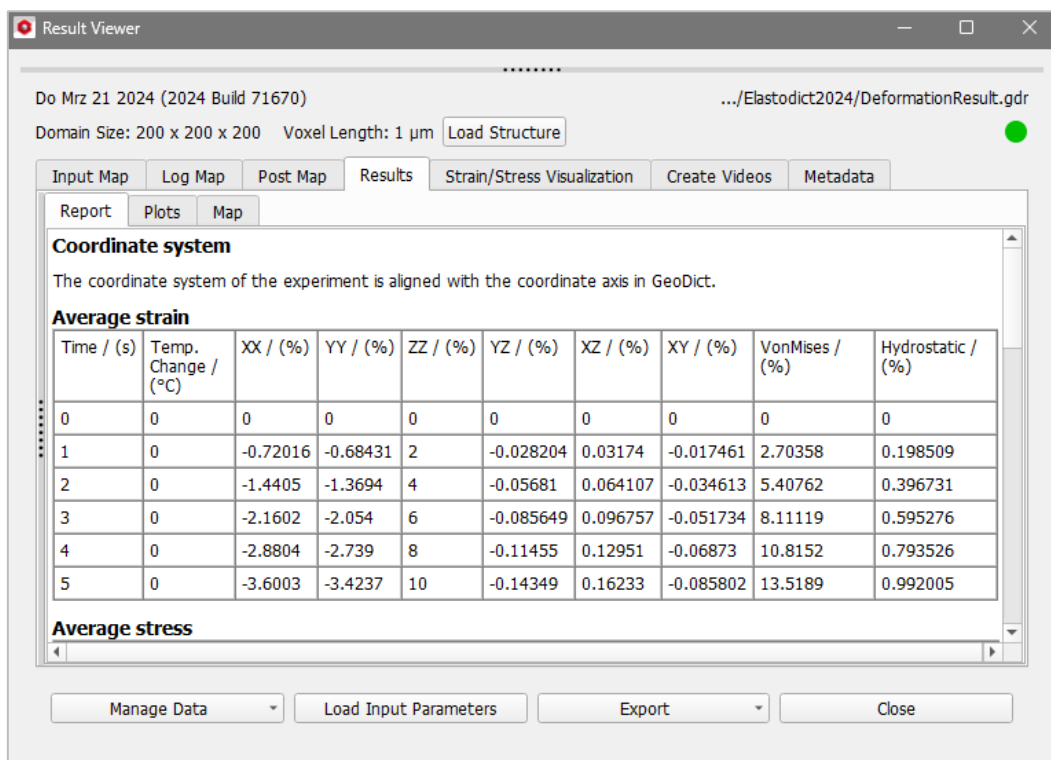

- The **Plots** subtab shows the stress-strain diagram by default. The parameters on the X/Y-Axis and the corresponding units are specified to the left of the plot. The new plot is created by clicking **Apply**. By right-clicking on the plot, it is possible to adjust the plot settings, for example, the font sizes, data range etc. Additionally, the plot can be saved as an image and the data can be saved as a *.txt file.

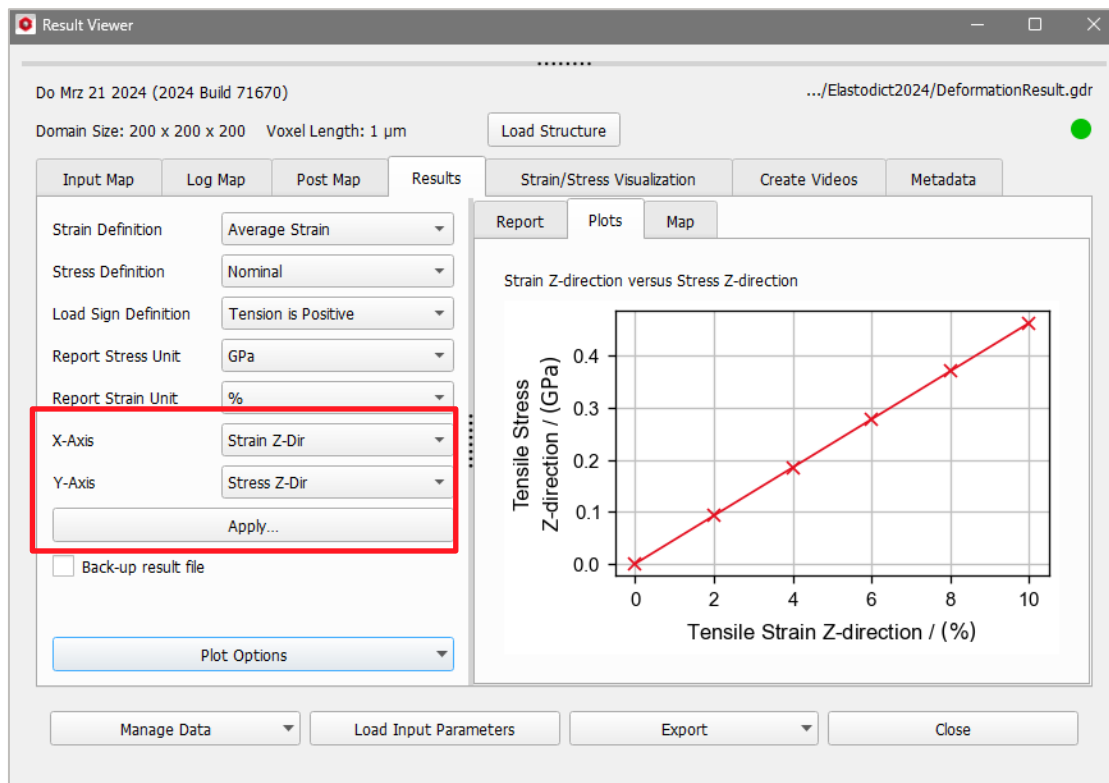

- The **Map** subtab contains all result values.

Key	Unit	Value
StructureFile		Structure.gdt
Runtime	s	138.81
PhysicalVisualization		
Information		
ErrorMessage		
InitialStiffness	GPa	4.626255
LoadCoordinateSystem		1, 0, 0, 0, 1, 0, 0, 0, 1
Step0		
Time	s	0
TemperatureChange	K	0
FluidPressure	GPa	0
DeformedVolumeFraction	1	0.899740125, 0.100259875, 0, 0, 0, 0, 0, 0, 0, 0, 0, 0, 0, 0, 0, 0, ...
GeometryVolume	m ³	8e-12
Strain		
Average	1	0, 0, 0, 0, 0, 0
AverageVonMises	1	0
AverageHydrostatic	1	0
Stress		

STRAIN/STRESS VISUALIZATION

In the **Strain/Stress Visualization** tab, the computed result fields (*.das) and deformed geometries (*.gdt) can be loaded into the **GeoDict** GUI for visualization and postprocessing purpose.

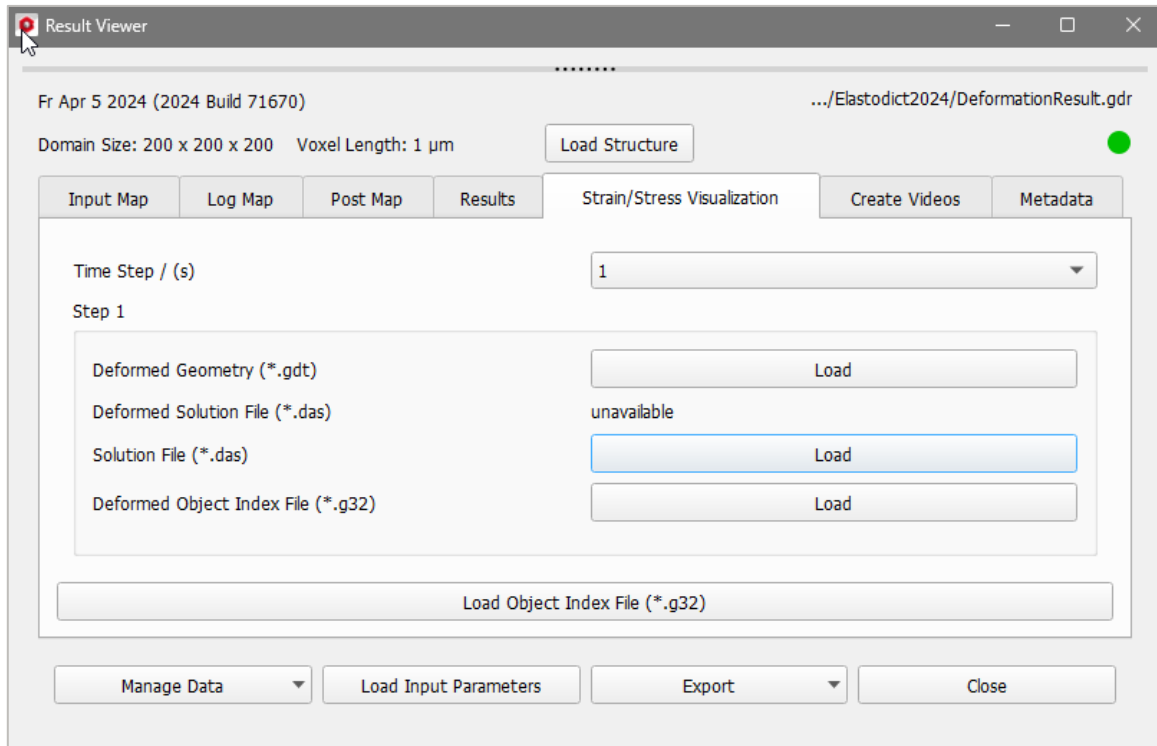

DEFORMED GEOMETRY

Since **GeoDict** 2022, the deformed geometries and volume fields are saved in boxels (instead of voxels as before).

Internally, **ElastoDict** works on boxels (cuboids with different side lengths), while **GeoDict** works on voxels (cubes).

Until **GeoDict** 2021, **ElastoDict** automatically resampled the structure to a voxel structure with the original voxel length (therefore, the voxel length did not change).

Since **GeoDict** 2022, **ElastoDict** saves the boxel structure directly. This change was necessary to enable the restart for simulations with **On Deformed Geometry**: The solver in **ElastoDict** needs the boxel structure for restarting the computations. With boxels, the number of elements does not change during the simulation.

Now, the resampling to a voxel structure is done when the structure is loaded in **GeoDict**. The smallest boxel side length is selected as the new voxel length (instead of the original voxel length as before). With this choice, more detail can be preserved especially for compression simulations and the structure is shown with more details.

It is also possible to load the structure with the original voxel length (as before in **GeoDict** 2021 and earlier). For this, the structure has to be imported by **selecting File → Import Structure (*.gdt)...** in the main GUI. The voxel length for the structure can be defined in **Voxel Length / (µm)**, below the **Resample to Voxels** checkbox. It is also possible to load the boxel geometry without resampling by unchecking **Resample to Voxels**.

The values for **CropX**, **CropY** and **CropZ** always correspond to the boxel geometry and do not represent the values of the resampled voxel geometry.

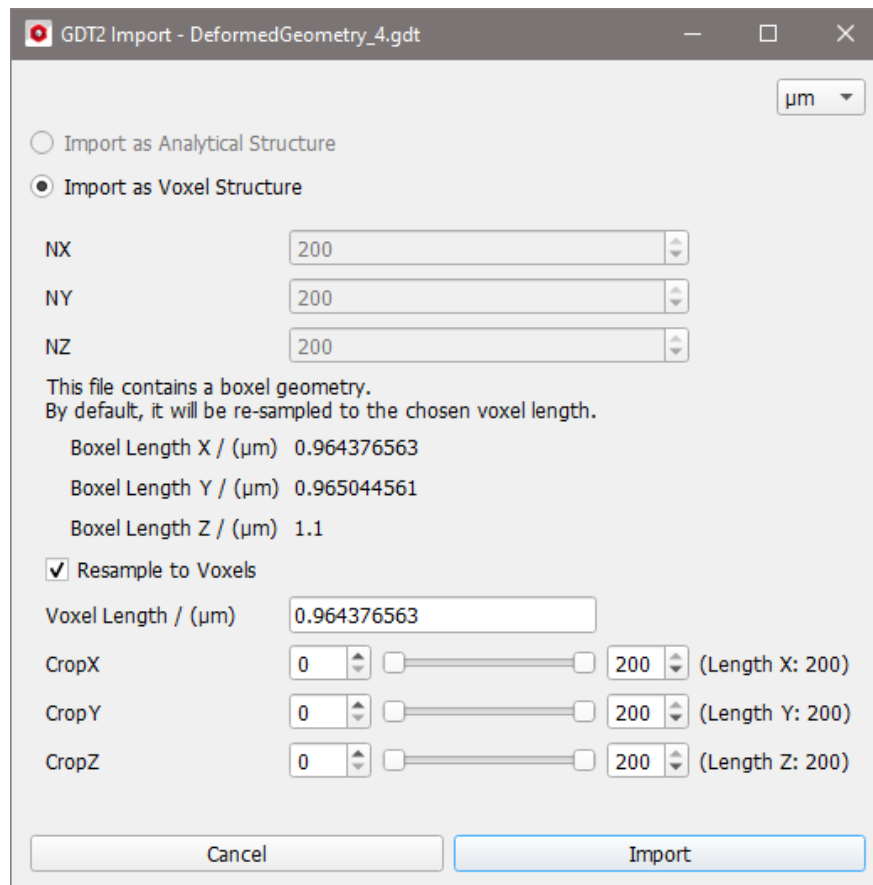

SOLUTION FILE

Depending on whether the calculation was made on deformed geometry or not (see [Geometry Handling](#)) the corresponding *.das file is available and can be loaded for each calculation step. In the example below, **Calculate on Deformed Geometry** in the **Geometry Handling** tab was unchecked, and thus only the **Solution File (*.das)** can be loaded.

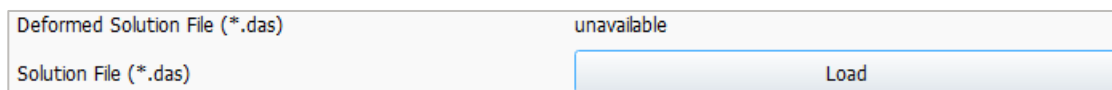

By clicking on **Load** (for both solution file options) a selection dialog opens. The result values, which are checked here, are visible in the **View Controls – Volume field** tab in the **GeoDict** GUI after the loading step is finished.

This is also the list of available result values which can be used if the **Manual** option is chosen for the video generation process, see [Create Videos](#) chapter on page [46](#). The choice of volume fields has to be made in the **Output** tab of the Large Deformation Options dialog before running the simulation, s. page [33](#).

After loading all required components, the visualization settings can be set for these values separately.

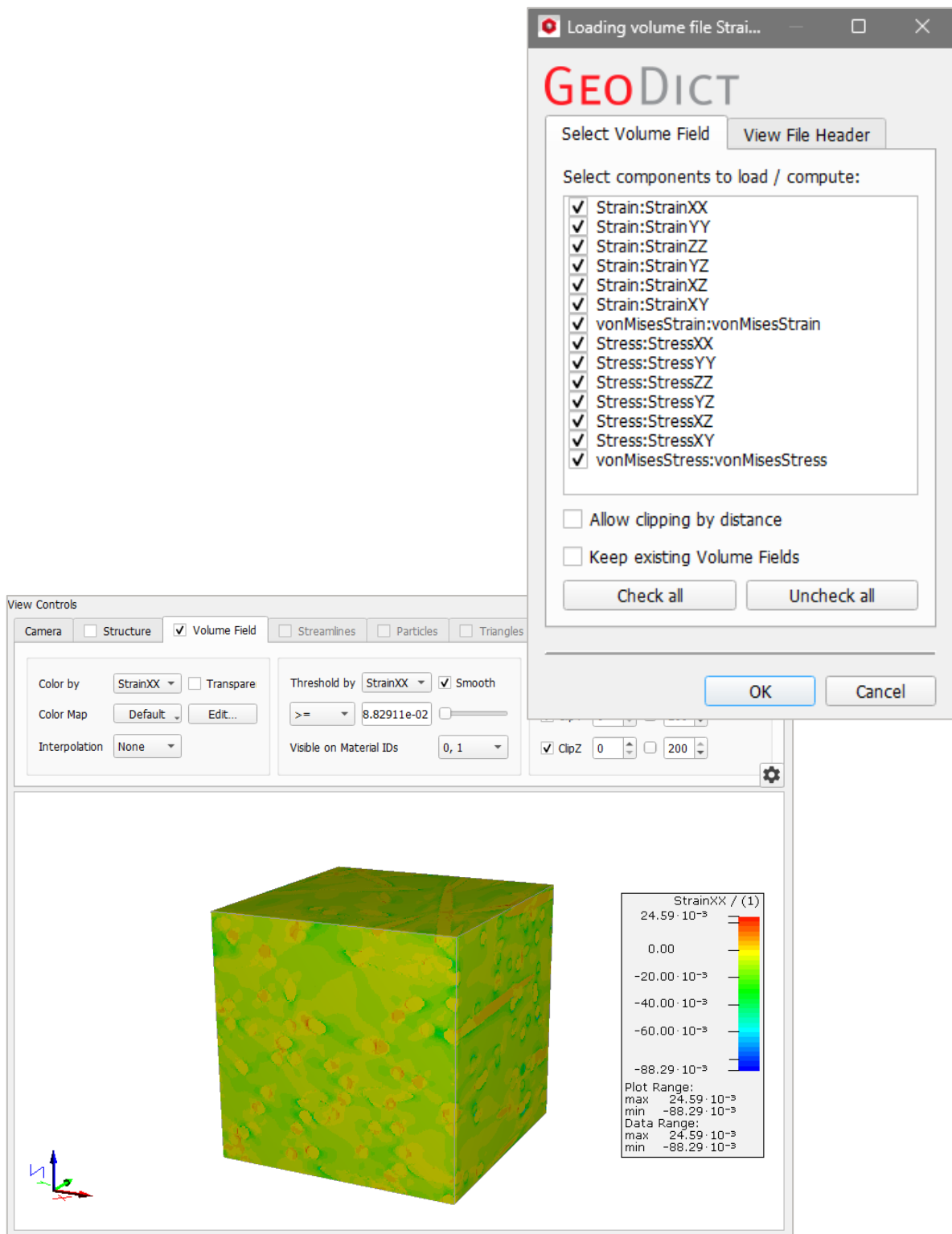

OBJECT INDEX FILE

The last two options in the **Strain/Stress Visualization** tab of the Result Viewer are for loading the **Object Index File (*.g32)**. In case the calculations were done on deformed geometry with **Enable Object Tracking (*.g32)** checked (see s. [Geometry Handling](#) options), the corresponding index file can be loaded.

By clicking on the **Load Object File Index (*.g32)** button at the bottom of the **Stress/Strain Visualization** tab the volume field with object indices of the undeformed structure is loaded.

The object indices of the deformed structure can be loaded by choosing **Load** for **Deformed Object Index File (*.g32)**. A dialog will open with a list of indices to choose. Additionally, the information about the resampling from boxels to a voxel structure procedure (described on page 42) is displayed.

Loading the Object Index File results for both cases in a colored representation of the different objects in the **Volume Field** tab. More information of each object can be viewed in the tooltip dialog.

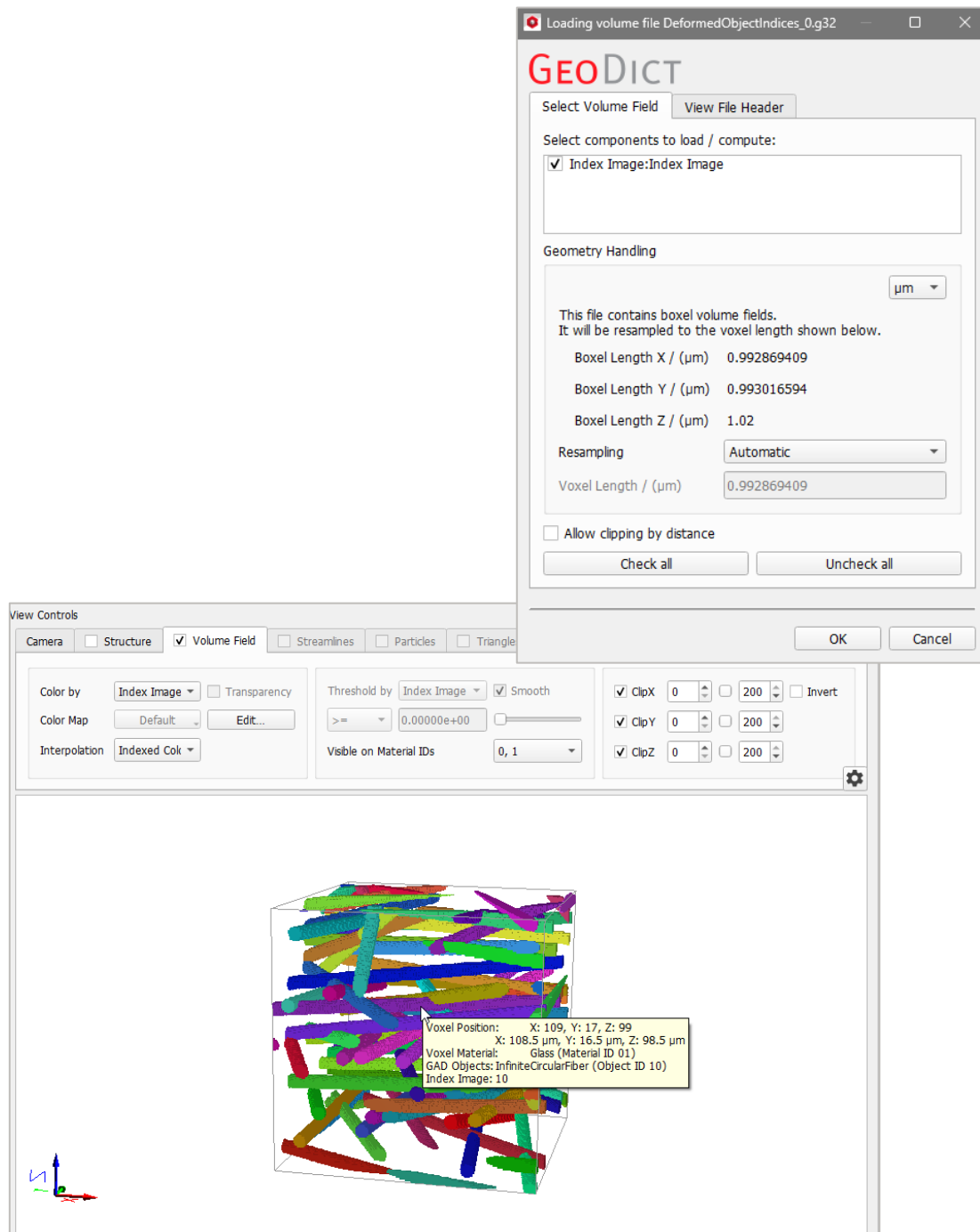

CREATE VIDEOS

The **Create Videos** tab allows to create a video of the current large deformation simulation directly from the results viewer. **Click Create Video...** to use the default settings or **Edit Parameters...** to set them to your needs. The video creation is performed with an underlying python macro which can be opened and edited with the **Open Macro File** button.

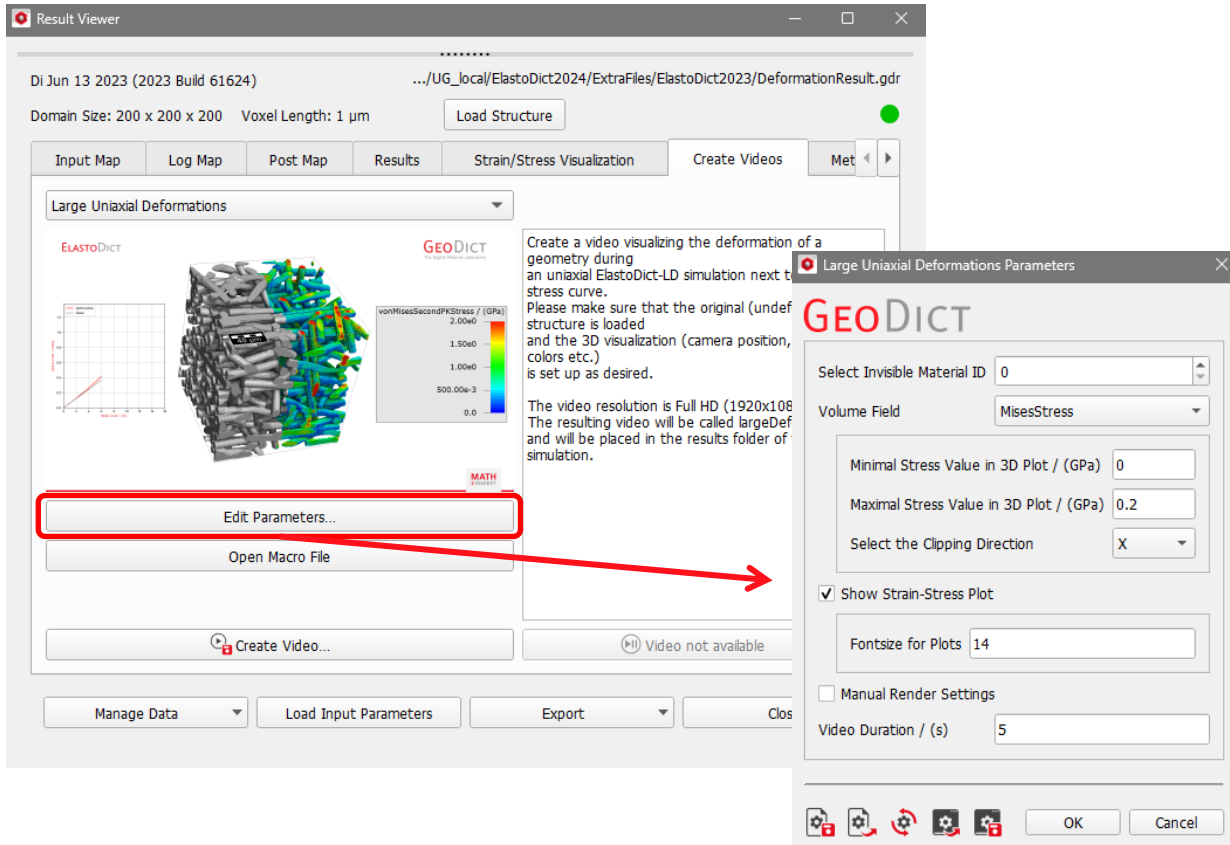

After the parameters are set, click **Create Video...** to create the video. After the generation is finished, the video file is saved in the result folder and can be opened with the **Play Video** button (see screenshot below).

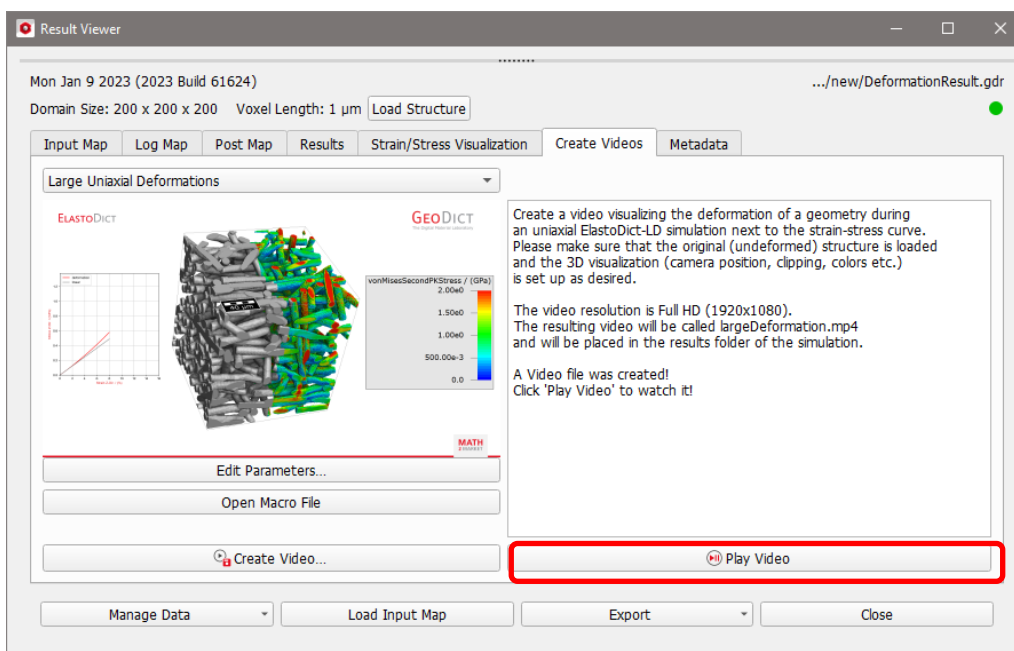

Since GeoDict 2024, it is also possible to create videos for other results than for von Mises strain or stress. For this, choose the **Manual** option in the **Edit Parameters** dialog and define the result value you want to record. The correct names for **Image Name** and **Field Name** can be looked up in the **Status and Modules** section of the GeoDict GUI or the solution field loading dialog described on page [Error! Bookmark not defined.](#)

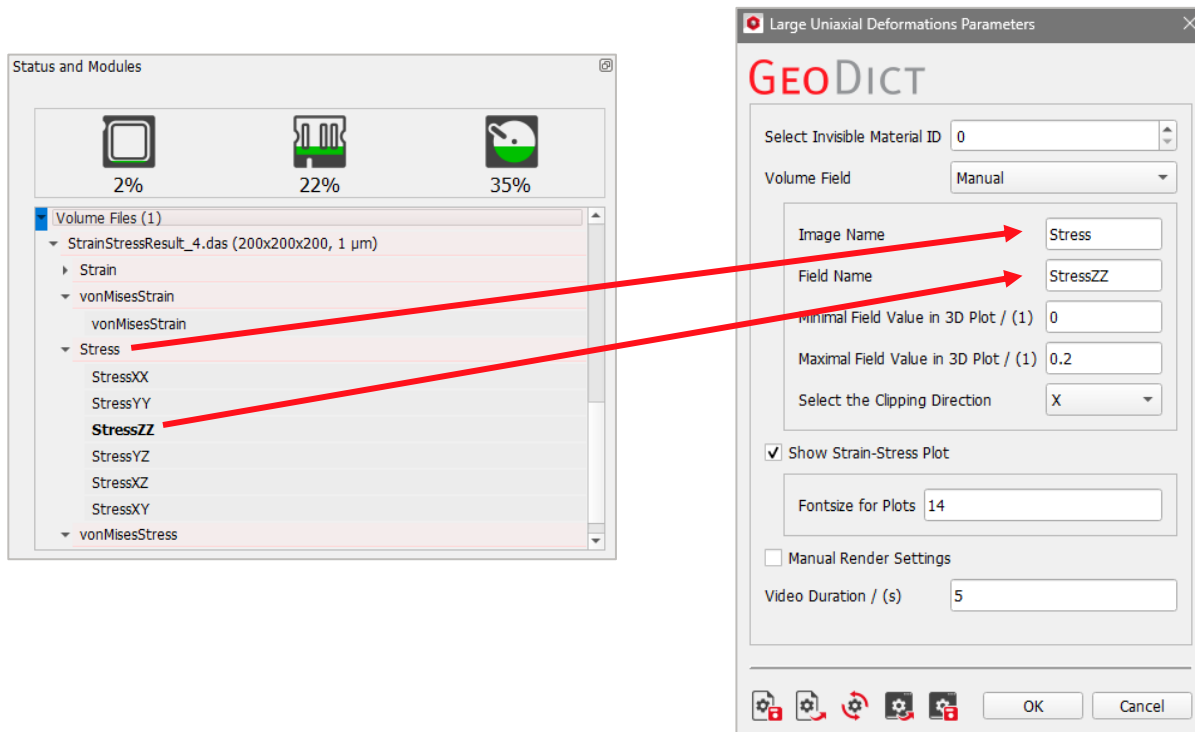

Note that **Deformed Solution Files** have to be calculated in the simulation, and all volume fields that are to be visualized in the video have to be checked in the **Output** tab (see page [33](#)). Before starting the video generation, the original geometry needs to be loaded.

METADATA

The **Metadata** tab contains a free text panel for additional input. Additionally, it contains the macro parameters when the simulation was started through a macro.

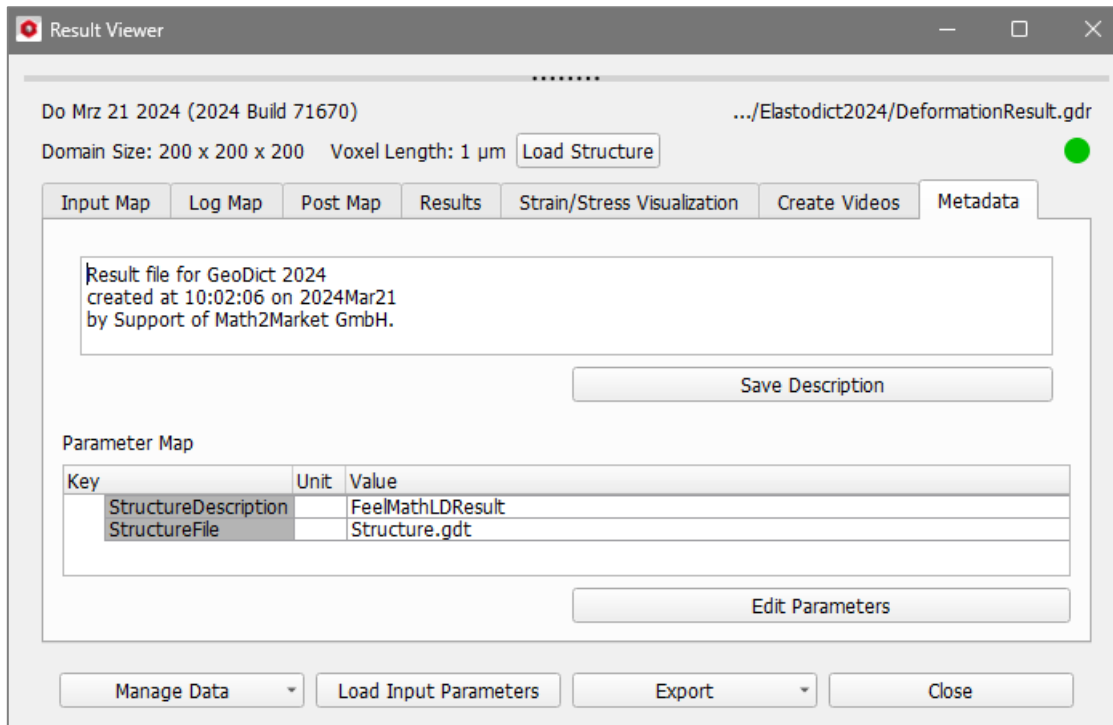

RESULT FOLDER

The result folder has the same name as the result file and is saved in the current project folder. It can be opened directly from the Result Viewer by right-clicking on the result file name and selecting **Open Result Folder**.

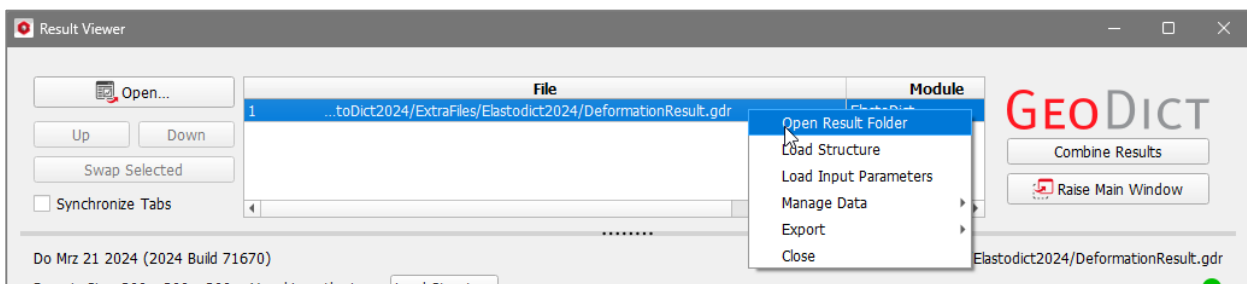

The result folder contains the following file formats:

- ***.gdt**: geometry data, e.g., the original structure and files with the deformed geometry (e.g., `DeformedGeometry_1.gdt`)
- ***.frf**: Free Report Form file (e.g., `EffectiveMatrix_2.frf`). It contains the results of each solution step. This information can also be found in the Results tab in the Results viewer.
- ***.cff**: coefficient file format (e.g., `MaterialParameters.cff`). This file contains the material properties of the materials in the structure as input data for the solver.
- ***.das**: e.g., `StrainStressResult_0.das`. These files contain the result fields and can be visualized in **GeoDict**. They can be loaded directly from the results viewer.

- ***.log**: e.g., `FeelMath.log`. A log file of the current solver run.
- ***.pde**: e.g., `SolverParameters.pde`. This file contains the parameters of the current simulations as input data for the FeelMath solver.
- ***.fmr** for `FeelMathRestart.fmr`: If a simulation is aborted, a restart file might be written which contains information to be used for a restart of the simulation. These files can be quite large, therefore they should only be kept if the simulation will be restarted later.
- ***.gdr.bck[i]**: e.g. `DeformationResult.gdr.bck1`: result file back-ups, which are generated if **Back-up result file** is checked in the **Result Viewer** → **Results** tab, s. page **Error! Bookmark not defined.**

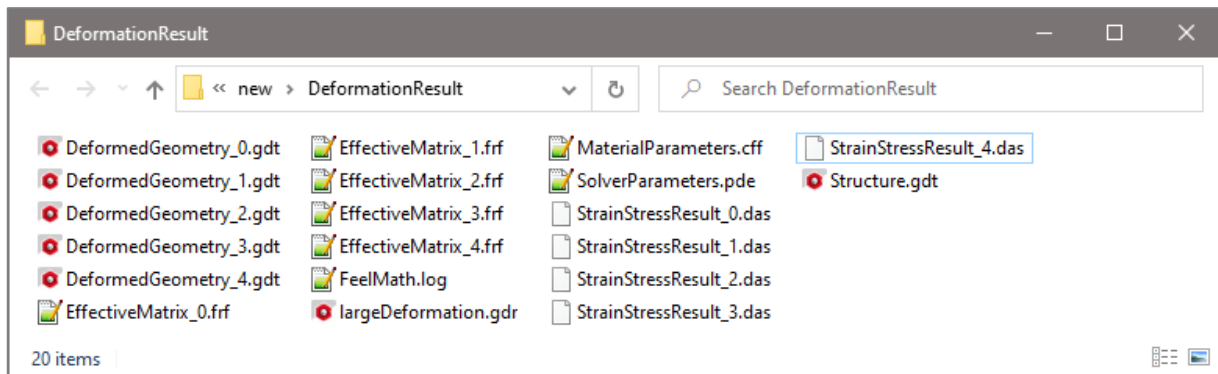

BENCHMARK RESULTS FOR DEFORMATIONS

As an example, the compression of a sand control screen is shown here.

The structure consists of 660 x 660 x 232 voxels (i.e., approximately 100 million voxels). A compression of 25 % is computed in 10 steps with plastic deformation of the structure.

Material Information:
 ID 00: Water [invis.]
 ID 01: Steel (S355JR - GOST 14249)
 ID 02: Steel (DIN EN 10130 - DC01)
 ID 03: Steel (C45E)

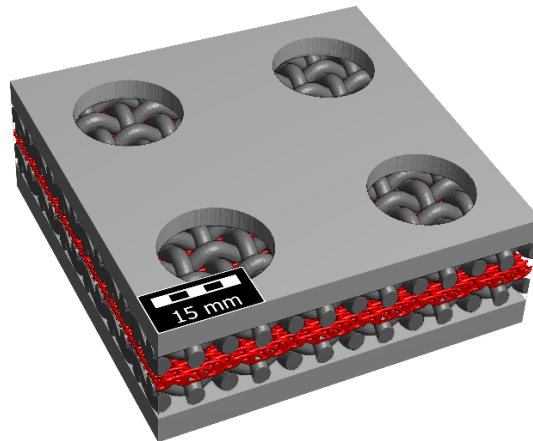

The computation was run on our server, with 2 x Intel E5-2697A v4 processors with 16 cores each, running with a maximum of 3.60 GHz, and 128 GB RAM under Linux.

Without writing the deformation data to a file, the computation with 32 processes, needs 50 % more memory, but the runtime is reduced by 40 % compared to **GeoDict** 2020. With **GeoDict** 2022, the runtime is further reduced by 10 % compared to **GeoDict** 2021. With **GeoDict** 2023, due to the support for 8-bit structures, the runtime and memory increase a little.

GeoDict release	Runtime /h	Memory / GB
2020 SP3	32.8	82
2021 (r42253)	19.6	123
2022 (r52998)	17.7	133
2023 (r60247)	18.3	133.5
2024 (r71884)	18.0	133.5

If keeping the deformed geometry in memory is combined with downsampling, computation time can be reduced even further.

The example shown next is the compression of a foam structure.

For a structure size of 500 x 500 x 500 voxels, a compression of 80 % is computed with **ElastoDict-Deformations** in 40 steps.

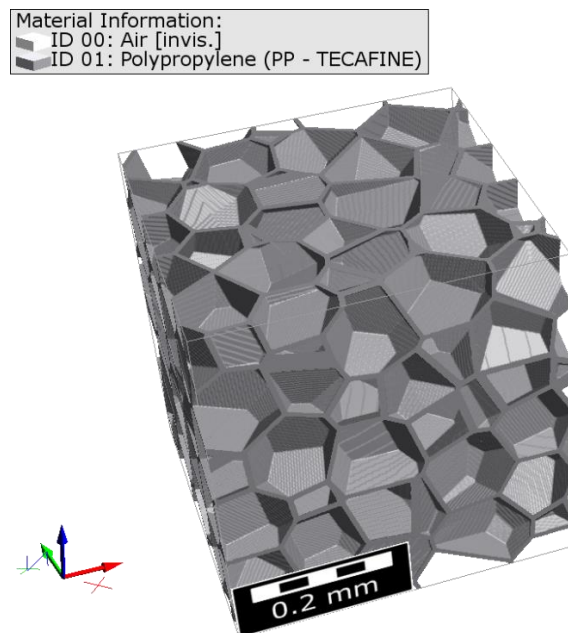

Again, computations were run with 32 processes on our server mentioned above.

Each computation is run twice, once for elastic, and once for plastic material behavior with **GeoDict 2024** Runtimes and memory requirements for the computation with and without downsampling (DS), as well as for keeping the deformed geometry in memory (InMem) or writing the deformation data to a file (OnDrive) are compared in the following figures.

With downsampling and keeping the deformed geometry in memory, runtimes can be reduced for the foam structure by more than 90 %, by reducing the required memory to 50 % for elastic case, and to 20 % for plastic case.

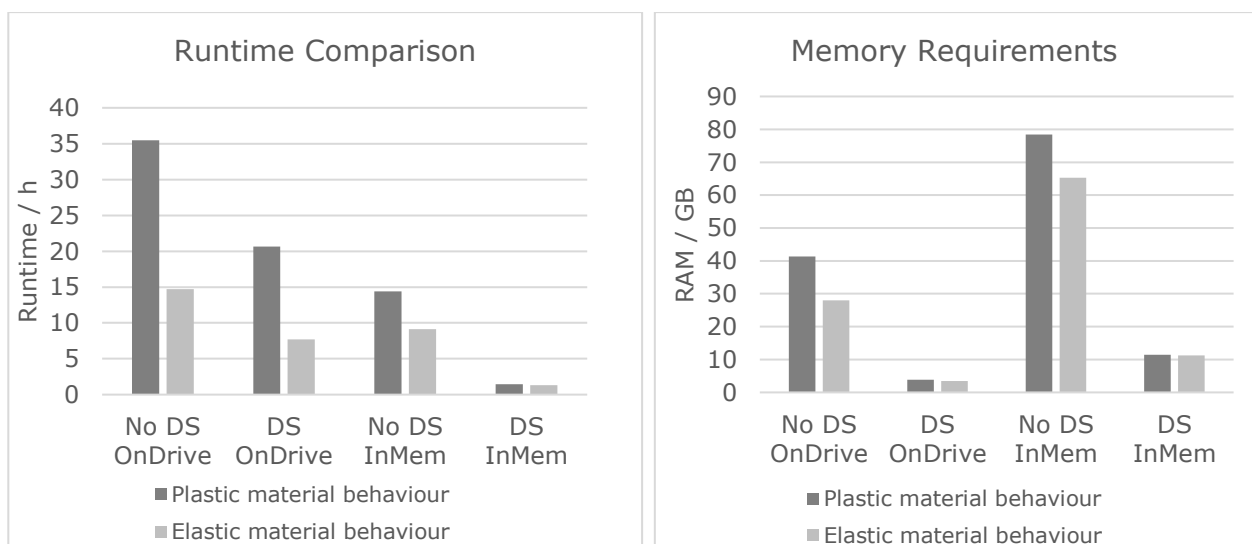

FLEXURAL TEST

With the **Flexural Test** option in **ElastoDict**, the reaction of a material to bending loads can be analyzed. As in most applications in **GeoDict**, only a small domain of the structure is needed for the simulation. However, it is necessary that the structure in **GeoDict** contains the complete height of the real structure.

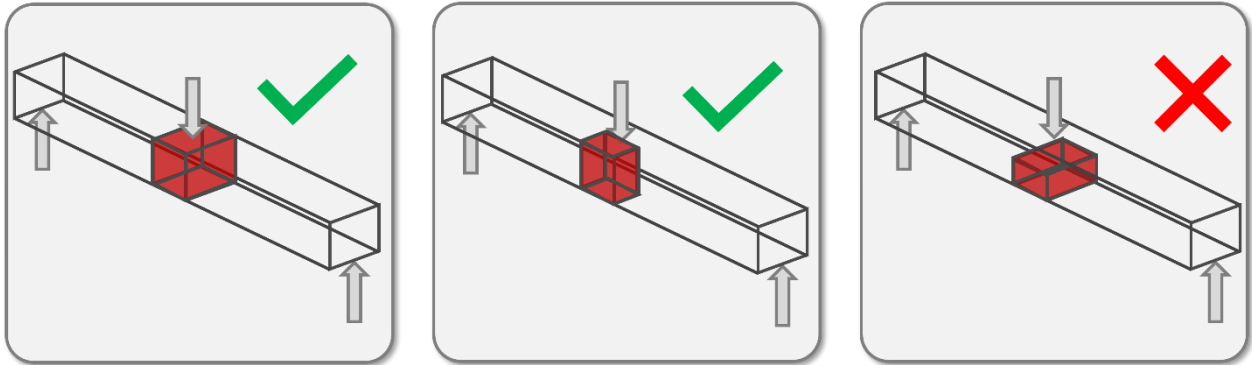

Click the Solver Options **Edit** button to set the simulations settings for large deformation simulations. In the **Flexural Test Options** dialog, choose a **Result File Name (*.gdr)** according to your current project.

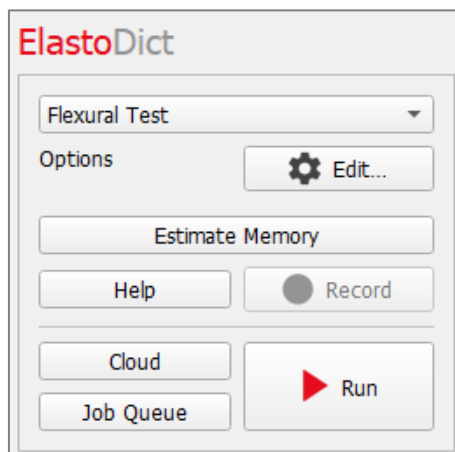

CONSTITUENT MATERIALS

Select the constituent materials of the structure model as indicated above in page [11](#) for **ElastoDict-Deformations**. For the flexural test, linear and nonlinear materials can be used.

MACROSCOPIC LOAD CASE

Under the **Macroscopic Load Case** tab, the experiment settings for the flexural test are defined.

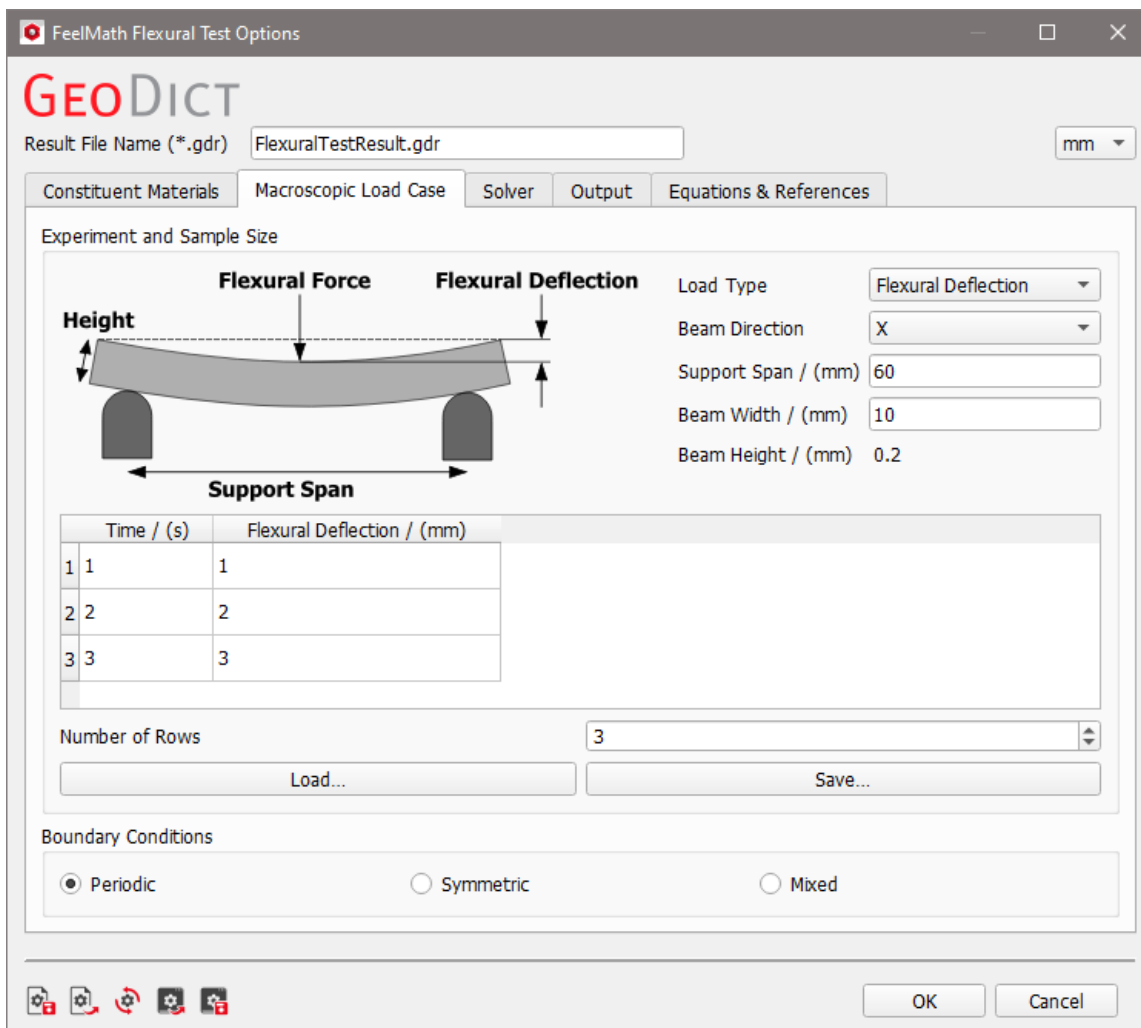

EXPERIMENT AND SAMPLE SIZE

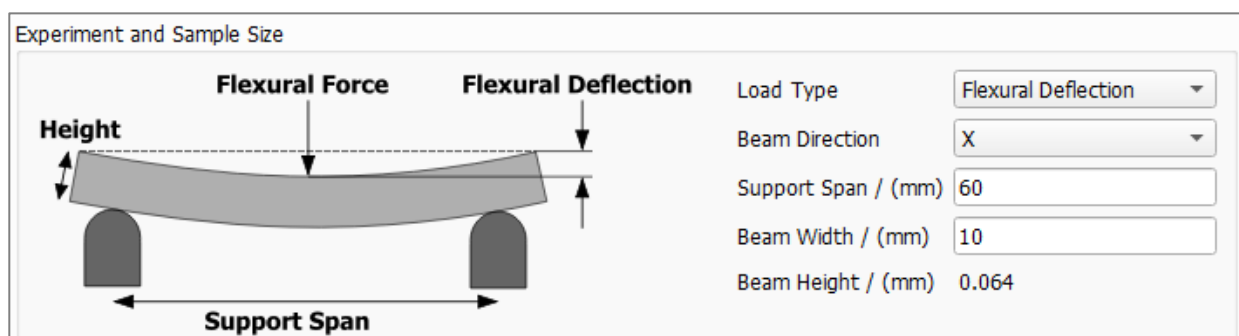

LOAD TYPE

The bending of the beam leads to compression in the upper part of the beam, and to tension in the lower part. This can also be understood as a **Strain Gradient** and **Stress Gradient** (see also the figure below). In GeoDict, the flexural test is computed based on these gradients. If **Flexural Deflection** or **Flexural Force** are defined, these gradients are automatically computed by GeoDict.

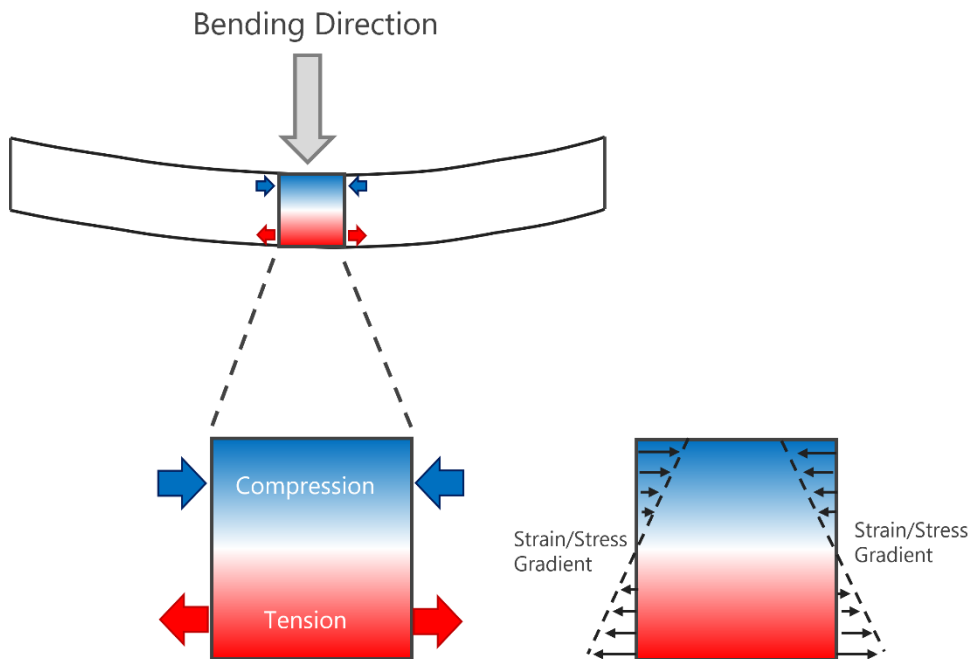

The load type can be defined as **Flexural Deflection** or **Flexural Force**, or alternatively as **Strain Gradient** or **Stress Gradient**. It is recommended to only use **Flexural Deflection** or **Flexural Force** here, the other (gradient) options are expert options. If possible, **Flexural Deflection** should be used, since it usually leads to a better convergence behavior than **Flexural Force** (see page [15](#) and page [106](#) for further information).

SUPPORT SPAN

The support span is the distance between the two supporting pins, as indicated in the picture under **Experiment and Sample Size**. It must be entered in the user interface, since the structure in **GeoDict** is usually a small cutout of the full sample.

BEAM WIDTH & BEAM HEIGHT

The **Beam Width** is perpendicular to the beam and bending directions. It influences the ratio between load and deflection (since the beam can carry higher loads if it is wider), but it has no influence on the effective material parameters like the flexural modulus. The value of the **Beam Height** cannot be changed, since height of the beam is the height of the structure in **GeoDict**.

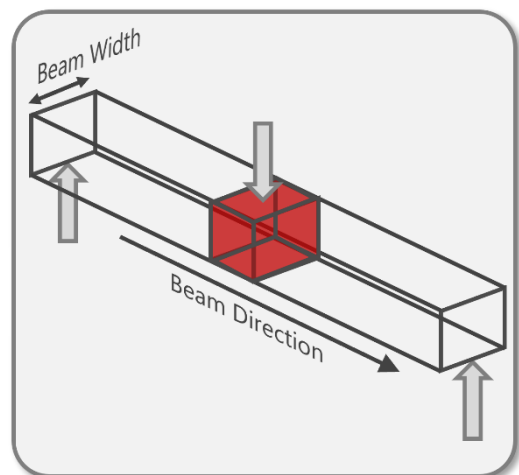

LOAD TABLE

In the **Load Table**, the load steps and the corresponding times can be defined. For computing the flexural modulus, one step is sufficient. More load steps are necessary to analyze more complicated effects like plasticity and damage.

SOLVER

The **Solver** tab is identical to the one for **ElastoDict-Deformations** (see page [61](#)).

OUTPUT

The options under the **Output** tab are identical to those for **ElastoDict-Deformations** (see page [33](#))

EQUATIONS & REFERENCES

The differential equations solved in the simulation and additional equations relevant for flexural tests are listed under the **Equations & References**. Additionally, the tab contains the references for the methods used by the FeelMath solver in **ElastoDict** (see page [1](#) for links).

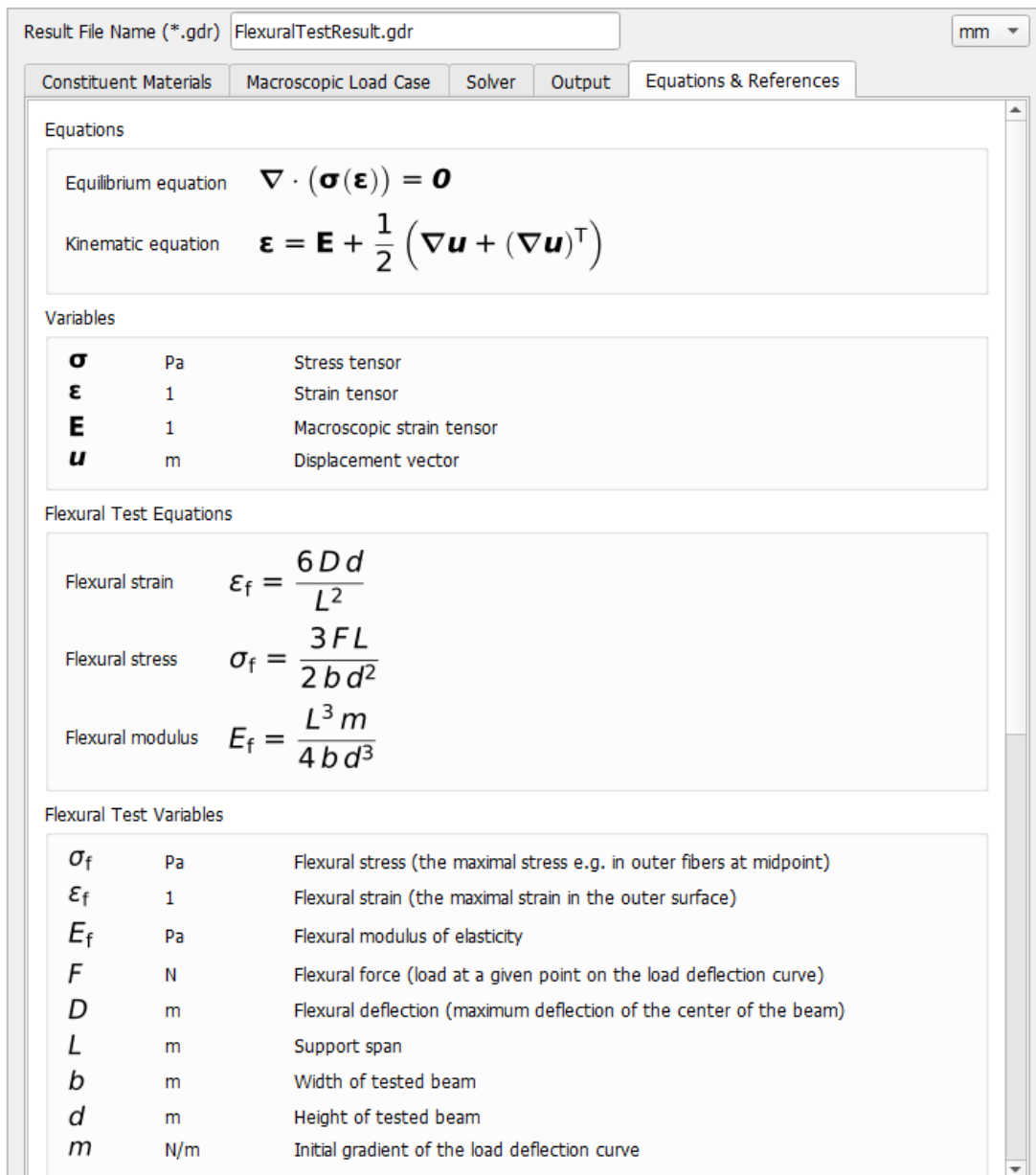

Result File Name (*.gdr) FlexuralTestResult.gdr mm

Constituent Materials Macroscopic Load Case Solver Output Equations & References

Equations

Equilibrium equation $\nabla \cdot (\boldsymbol{\sigma}(\boldsymbol{\varepsilon})) = \mathbf{0}$

Kinematic equation $\boldsymbol{\varepsilon} = \mathbf{E} + \frac{1}{2} (\nabla \mathbf{u} + (\nabla \mathbf{u})^T)$

Variables

$\boldsymbol{\sigma}$	Pa	Stress tensor
$\boldsymbol{\varepsilon}$	1	Strain tensor
\mathbf{E}	1	Macroscopic strain tensor
\mathbf{u}	m	Displacement vector

Flexural Test Equations

Flexural strain $\varepsilon_f = \frac{6Dd}{L^2}$

Flexural stress $\sigma_f = \frac{3FL}{2bd^2}$

Flexural modulus $E_f = \frac{L^3m}{4bd^3}$

Flexural Test Variables

σ_f	Pa	Flexural stress (the maximal stress e.g. in outer fibers at midpoint)
ε_f	1	Flexural strain (the maximal strain in the outer surface)
E_f	Pa	Flexural modulus of elasticity
F	N	Flexural force (load at a given point on the load deflection curve)
D	m	Flexural deflection (maximum deflection of the center of the beam)
L	m	Support span
b	m	Width of tested beam
d	m	Height of tested beam
m	N/m	Initial gradient of the load deflection curve

RESULTS FILE (.GDR)

The handling of the result file works analogous as for **ElastoDict-Deformations** (page [37](#)). Only the features specific for the flexural test are explained here in detail.

RESULTS

The results tab contains a table with the forces and corresponding deflections in the experiment. Additionally, the flexural modulus is computed based on the first step of the simulation.

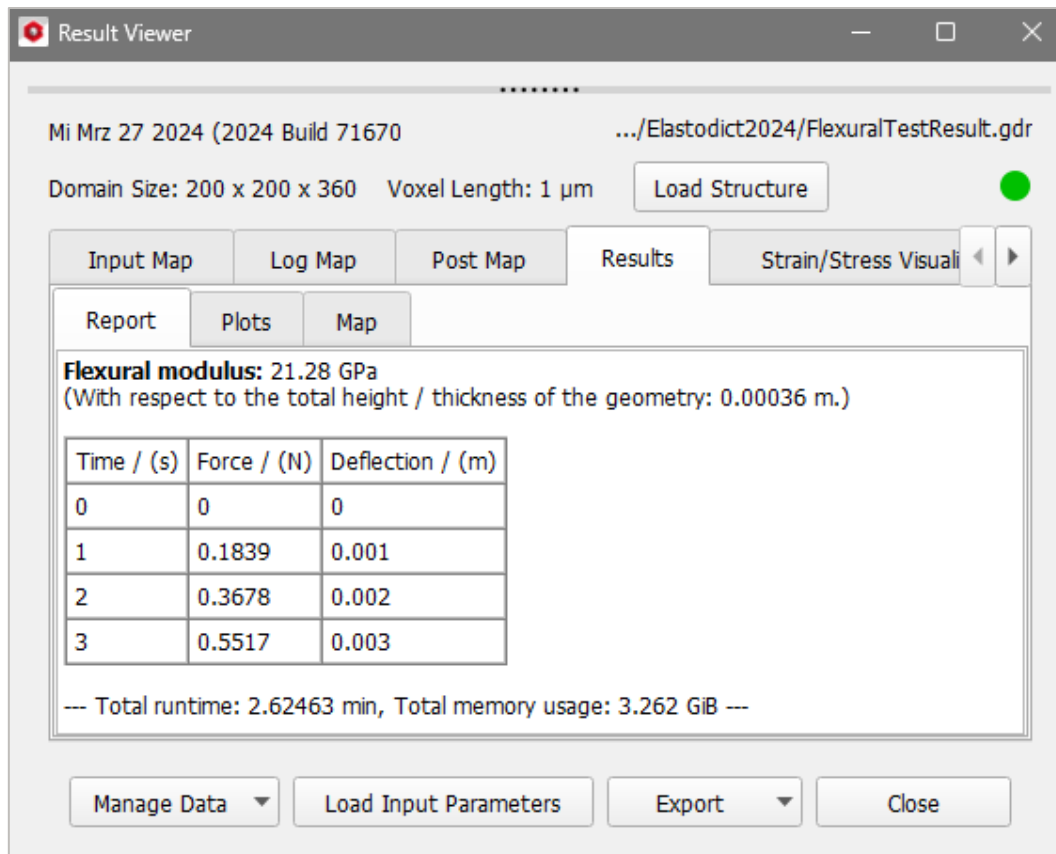

STRAIN/STRESS VISUALIZATION

In the **Strain/Stress Visualization** tab, the computed result fields (*.das) and deformed geometries (*.gdt) can be loaded into **GeoDict** for visualization.

In the example below, a flexural test is done on a beam with a material structure as shown on the left. On the right, the distribution of the strain in X-direction is shown, and it is visible that the compressed on the top (negative strain, colored in blue) and stretched on the bottom (positive strain, colored in red).

Make sure, that all displacements, strains and stresses of interest are chosen in the **Output** tab to be written in the result files, see page [33](#).

The simulation is based on the strain or stress gradients in the beam in the load direction. Therefore, it is not possible to see the bending in the results. This corresponds to the idea of analyzing a very small part of the beam.

Material Information:
ID 00: Epoxy (3501-6) [invis.]
ID 01: Glass

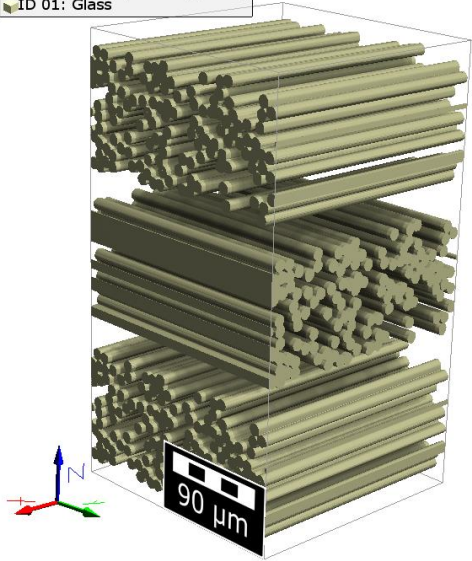

Material Information:
ID 00: Epoxy (3501-6) [invis.]
ID 01: Glass

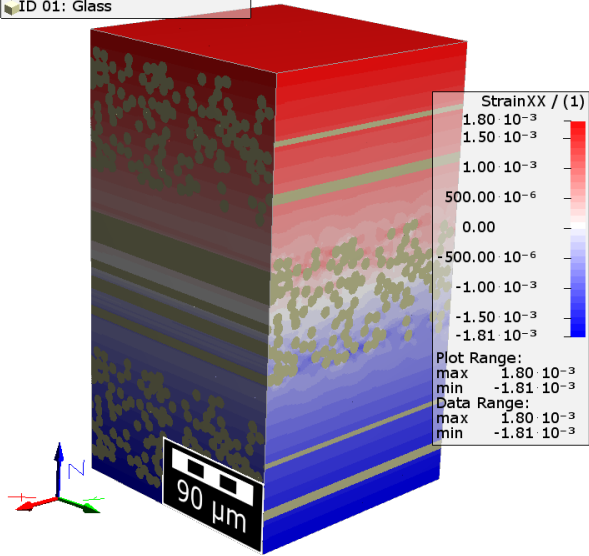

EFFECTIVE STIFFNESS

With **ElastoDict**-Effective stiffness, the effective elastic properties of a given structure can be computed. Effective elastic properties are the mechanical properties of a homogeneous material which shows the same elastic behavior as the given non-homogenous material.

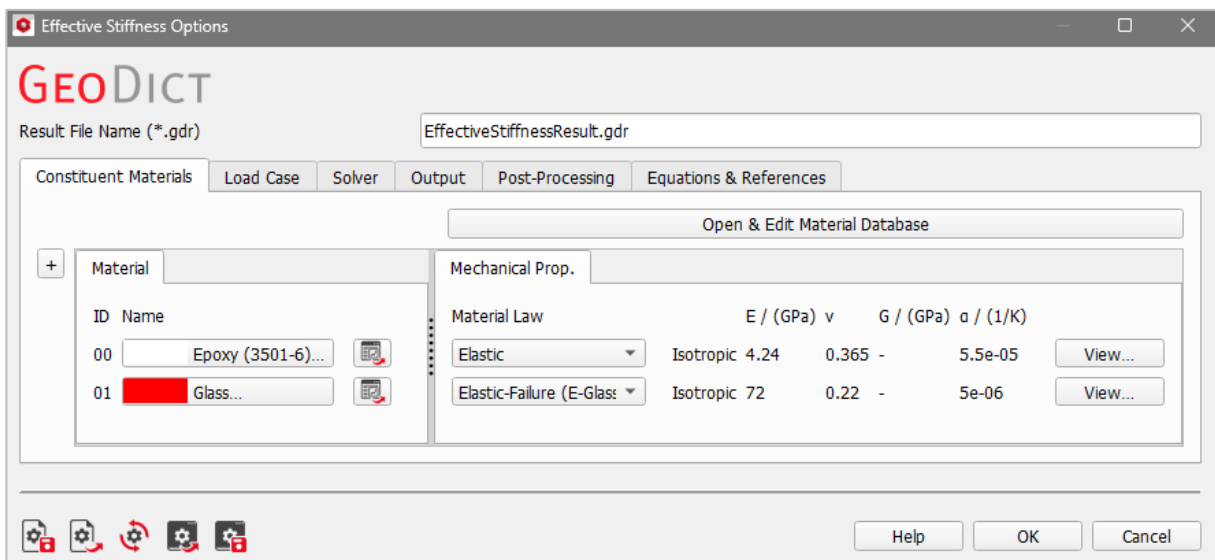
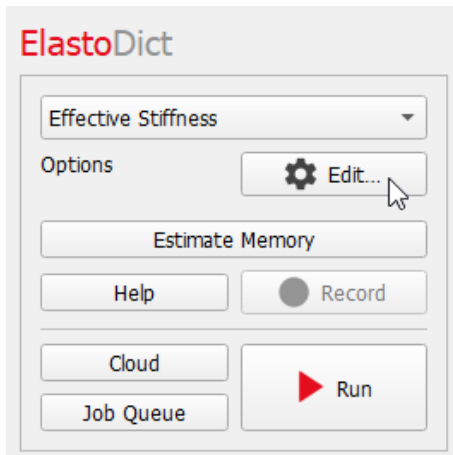

In the **Effective Stiffness Options** dialog, choose the **Result File Name (*.gdr)** as you wish.

If a **GeoDict** results file (*.gdr) with the given name already exists in the project folder, a warning message is shown at the start of the creation process. The user can either decide to back up the old file, to overwrite it or cancel and choose a new file name. If no action is taken, the default option back-up is automatically chosen after a waiting time.

CONSTITUENT MATERIALS

Select the constituent materials of the structure model as indicated above in page [11](#) for **ElastoDict**-Deformations. In **ElastoDict**-Effective Stiffness, only linear elastic materials can be used.

LOAD CASE

In the **Load Case** tab, the loads applied to the geometry are defined.

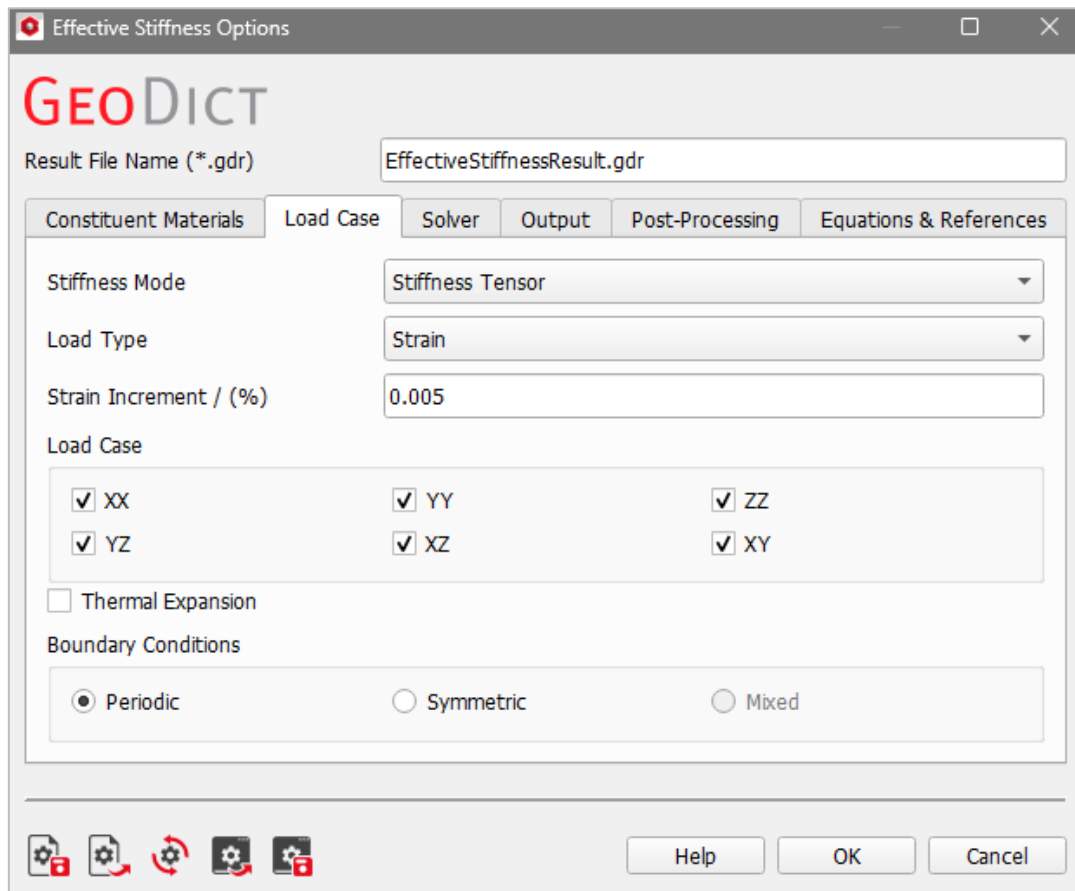

LOAD TYPE

Choose whether the load applied to the material should be **Strain** or **Stress** from the pull-down menu. Choosing **Strain** is favorable for the solver and is often faster, but the choice has no effect on the quality of the solution.

STIFFNESS MODE

Either the **Stiffness Tensor** for the structure, or the effective stiffness for a selected direction can be computed (**Stiffness X-Direction**, ...).

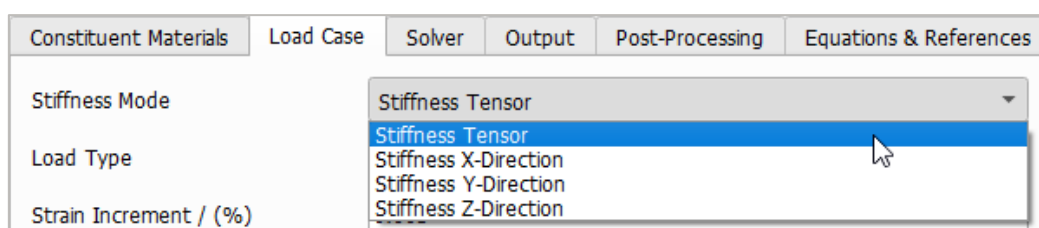

The stiffness tensor contains more information and allows to understand the properties of the structure more thoroughly. Nevertheless, if only the information for one direction is needed, the option to compute only a selected direction is much faster.

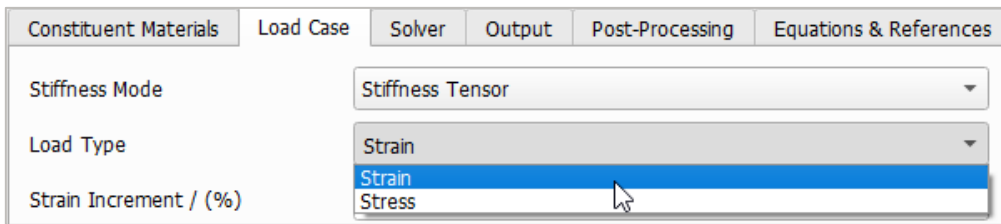

STRAIN/STRESS INCREMENT

Depending on the selected **Load Type**, a **Strain** or **Stress Increment** must be set. Generally, it is recommended to keep the default settings. Since the equation solved in **ElastoDict-Effective Stiffness** is linear, scaling the input increment (**Strain** respectively **Stress**) by a factor also scales the output (**Stress** respectively **Strain**) by the same factor. In conclusion, changing the input increment does not change the computed stiffness tensors.

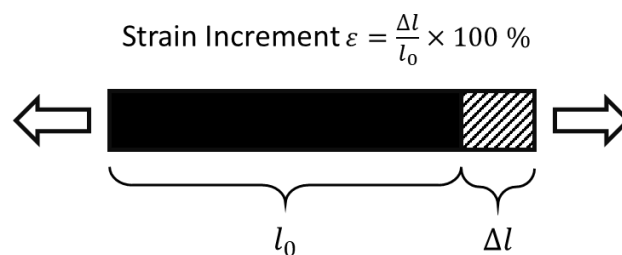

LOAD CASE

Choose the **Load Directions** in which the effective stiffness should be calculated. The complete stiffness tensor can only be computed if all six load case directions are simulated (See the Appendix about the effective elastic properties on pages [130](#) ff. for an exemplary analysis of **ElastoDict-Effective Stiffness** results). Otherwise, only part of the stiffness tensor is calculated. If only parts of the stiffness tensor are computed, the results might be inaccurate, especially if the structure is highly anisotropic. Therefore, we recommend using the option to compute the stiffness in selected directions (see **Stiffness Tensor**, page [59](#)) instead of computing only parts of the stiffness tensor.

For the strain equivalence principle (see the **Solver** tab), each load case adds one column to the stiffness tensor. For the energy equivalence principle, only the entries of the stiffness tensor can be calculated, for which both the load case belonging to the column-number and the load case belonging to the row-number, have been solved.

THERMAL EXPANSION

When thermal expansion is chosen, the tensor with the thermal expansion coefficients is computed for the current structure. Thermal expansion is a separate load case independent from the strain or stress loads. The temperature change is then specified as **Temperature Increment [K]**.



BOUNDARY CONDITIONS

Here, the domain boundary conditions can be set. In general, periodic boundary conditions should be used for periodic structures, whereas otherwise symmetric boundary conditions should be applied. For further explanations, see the corresponding paragraph in the [ElastoDict-Deformations](#) section (pages [15](#) ff.).

For the **FeelMath** solver (explained under **Solver** below), periodic boundary conditions are usually much faster and need less memory than symmetric boundary conditions. In many cases, for example for composite structures with low fiber percentage, the results for periodic boundary conditions are comparable with the results for symmetric boundary conditions even if the analyzed structure is not periodic.

The **LIR** solver is less affected by the choice of the boundary conditions. Usually, it is slightly faster with symmetric boundary conditions than with periodic boundary conditions.

If the **Stiffness Mode** is set to **Stiffness Tensor**, only **Periodic** or **Symmetric** boundary conditions are available. For **Stiffness in X,Y or Z-Direction**, also **Mixed** boundary conditions can be set. Mixed boundary conditions are symmetric in the load direction and periodic in the tangential directions. They are usually faster to calculate than symmetric boundary conditions.

SOLVER

Since [GeoDict 2023](#), two solvers are available for the **Effective Stiffness** calculation: **FeelMath** and **LIR**. The **FeelMath** solver is developed at Fraunhofer ITWM since over a decade. It is more versatile, has more features and is currently recommended for most use cases. The **LIR** solver is developed in-house at Math2Market and is already known and refined from other modules, like e.g. [FlowDict](#). For effective stiffness calculations, it has a low memory consumption on highly porous structures, and it is fast with symmetric boundary conditions.

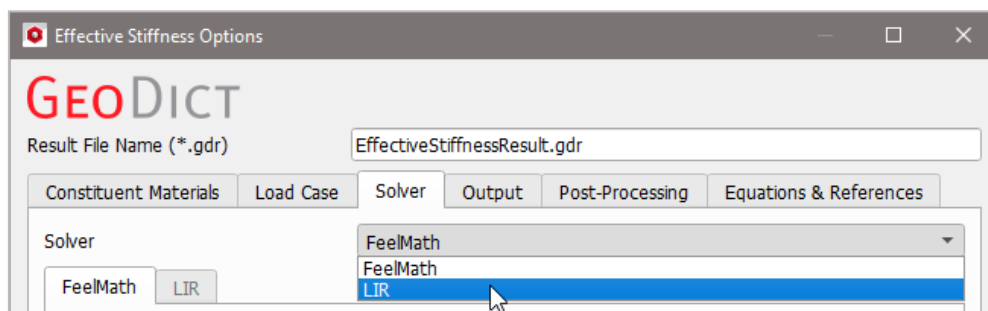

Internally, both solvers solve several equations for strain and stress at each voxel by using iterative solvers. The basic idea of an iterative method is to:

4. Start with some initial guess for the unknown values,
5. Improve the current values in each iterative step. The improvement can be fast or extremely slow depending on problem parameters,
6. Repeat the iterative process until the stopping criteria is fulfilled.

The parameters for **FeelMath** and **LIR** differ and are explained in the following two sections.

FEELMATH

The **ElastoDict**-Effective Stiffness FeelMath solver options are mostly the same as for the **ElastoDict**-Deformations (see page [29](#)). Here, the Equivalence Principle can be chosen additionally, which is not available for **ElastoDict**-Deformations.

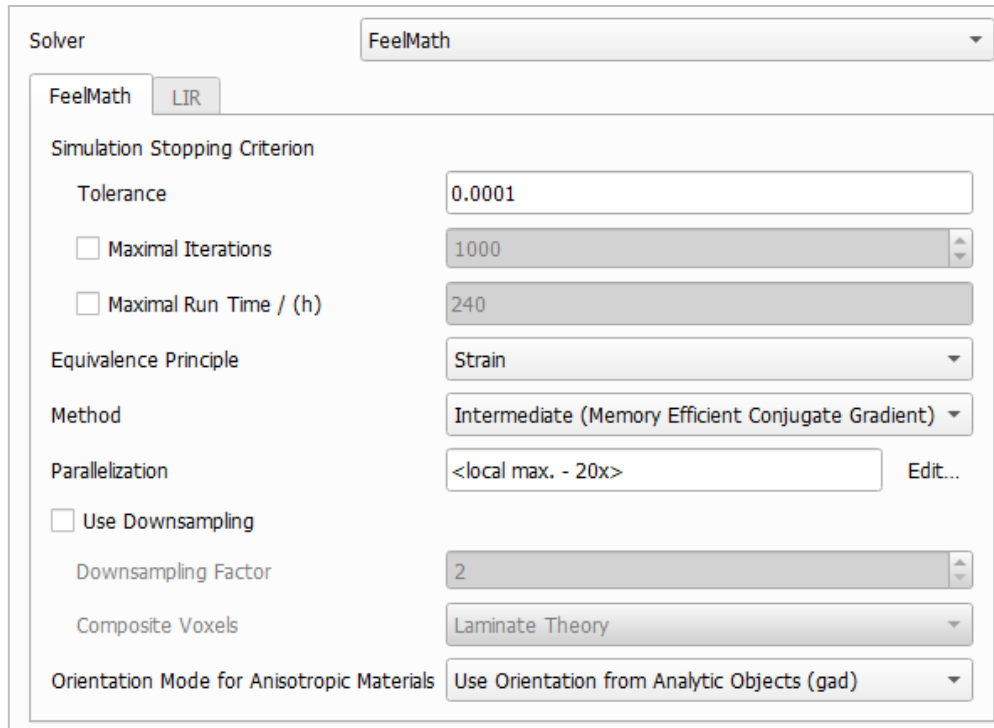

The screenshot shows the 'FeelMath' solver configuration window. The 'Solver' dropdown is set to 'FeelMath'. Below it, there are two tabs: 'FeelMath' (selected) and 'LIR'. The 'Simulation Stopping Criterion' section includes 'Tolerance' (0.0001), 'Maximal Iterations' (1000), and 'Maximal Run Time / (h)' (240). The 'Equivalence Principle' is set to 'Strain'. The 'Method' is 'Intermediate (Memory Efficient Conjugate Gradient)'. 'Parallelization' is set to '<local max. - 20x>' with an 'Edit...' button. There are checkboxes for 'Use Downsampling' (unchecked) and 'Use Orientation from Analytic Objects (gad)' (checked). Other settings include 'Downsampling Factor' (2) and 'Composite Voxels' (Laminate Theory).

EQUIVALENCE PRINCIPLE

The **Equivalence principle** defines the equations which are solved for the computation of the effective properties of the structure. In principle, the effective properties are the properties of a homogeneous material with the same properties as the given structure. There are two approaches to compute these properties:

- Based on **Strain Equivalence**: the stress caused by a given strain is the same for the homogeneous and non-homogeneous material.
- Based on **Energy and Strain Equivalence**: the elastic energy stored in the material caused by a given strain is the same in the homogeneous and non-homogeneous material. The strain equivalence is calculated additionally to the strain equivalence if this option is chosen.

In **ElastoDict**-Effective Stiffness, either only **Strain Equivalence** or **Energy and Strain Equivalence** can be chosen. By computing the latter, also the deviation in the results of both methods is evaluated in the result file and provides a measure for the quality of the solution. Depending on the structure, both methods might lead to slightly different results.

Downsampling

For **Downsampling**, all options are the same as for large deformation simulations (see page [31](#)).

ORIENTATION MODE FOR ANISOTROPIC MATERIALS

For **Orientation Mode for Anisotropic Materials**, all options are the same as for large deformation simulations (see page [32](#)).

LIR

The solver parameters for the LIR solver differ from those of the FeelMath solver and are explained below.

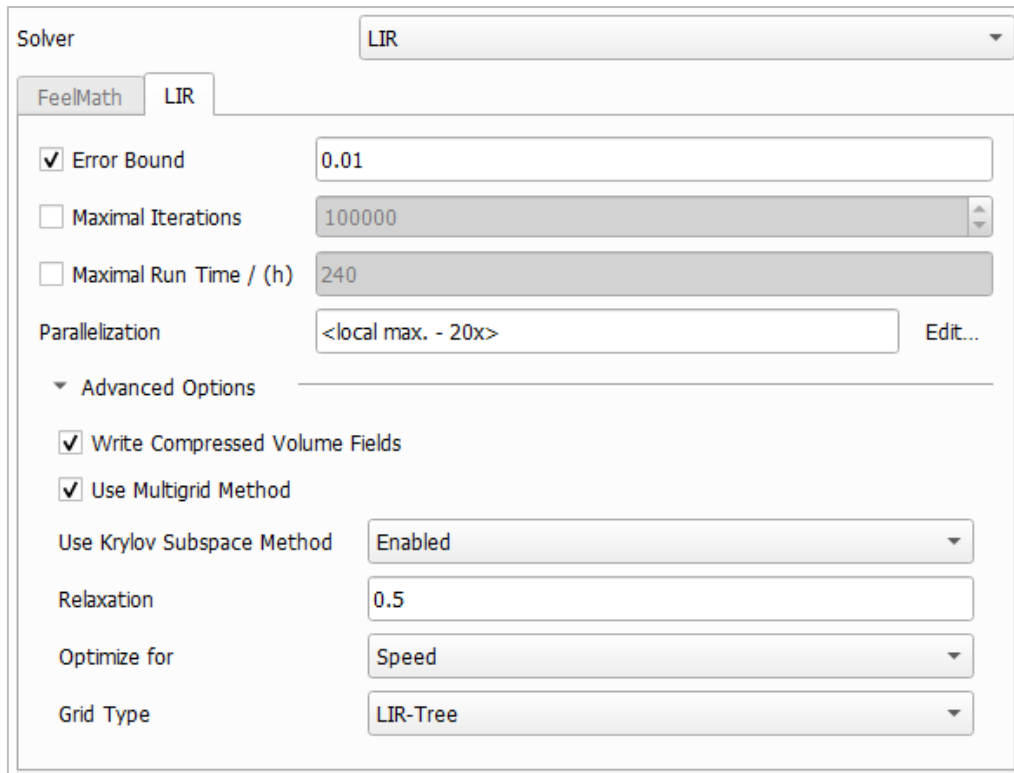

Solver: LIR

FeelMath | LIR

Error Bound: 0.01

Maximal Iterations: 100000

Maximal Run Time / (h): 240

Parallelization: <local max. - 20x> Edit...

Advanced Options

Write Compressed Volume Fields

Use Multigrid Method

Use Krylov Subspace Method: Enabled

Relaxation: 0.5

Optimize for: Speed

Grid Type: LIR-Tree

Relaxation

Depending on the material parameters and geometrical structure of the structure, the underlying mathematical problem can vary in complexity, thus influencing the behavior of the solver. The more complex the problem is, the more stable the solver settings should be, resulting in higher number of iterations, slower time stepping, and longer mechanical solver run times. However, making the solver run less iterations and, thus, faster, implies the risk that the solver does not converge.

For the **LIR** solver, this balance is managed through the **Relaxation**. The value should be between zero and two. For relaxation values smaller than one (<1.0), the simulation is more stable. For relaxation values larger than one (>1.0), the simulation is faster.

Optimize for

The **LIR** solver can **Optimize for** speed or memory.



Optimize for: Speed

Memory

Speed

If **Speed** is chosen, the solver constructs additional optimization structures. The runtime is decreased by up to 30 % but requires up to 50 % more memory compared to the other option. If **Memory** is chosen, then the runtime is increased by up to 40 % but the solver requires up to 50 % less memory.

Grid Type

The **Grid Type** decides what kind of tree structure is used for the simulation.

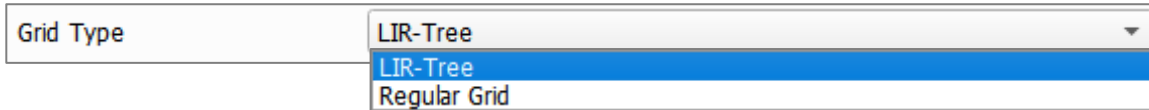

The default option **LIR-Tree** is the recommended grid type. The solver uses an adaptive tree structure called LIR-tree and needs up to 10 times less runtime and memory compared to the **Regular Grid** option.

OUTPUT

The **ElastoDict-Effective Stiffness Output** options are mostly the same as for **ElastoDict-Deformations** (see page [33](#)).

The option to **Delete Result Folder after Simulation** is only available for Effective Stiffness. When this option is chosen, only the .gdr file is kept after the run and the corresponding solver files are deleted (log files, solver input files, result files, ...). This option is useful when only the effective properties are of interest and no result fields are needed.

The option **Export VTK File** is not available for the LIR solver.

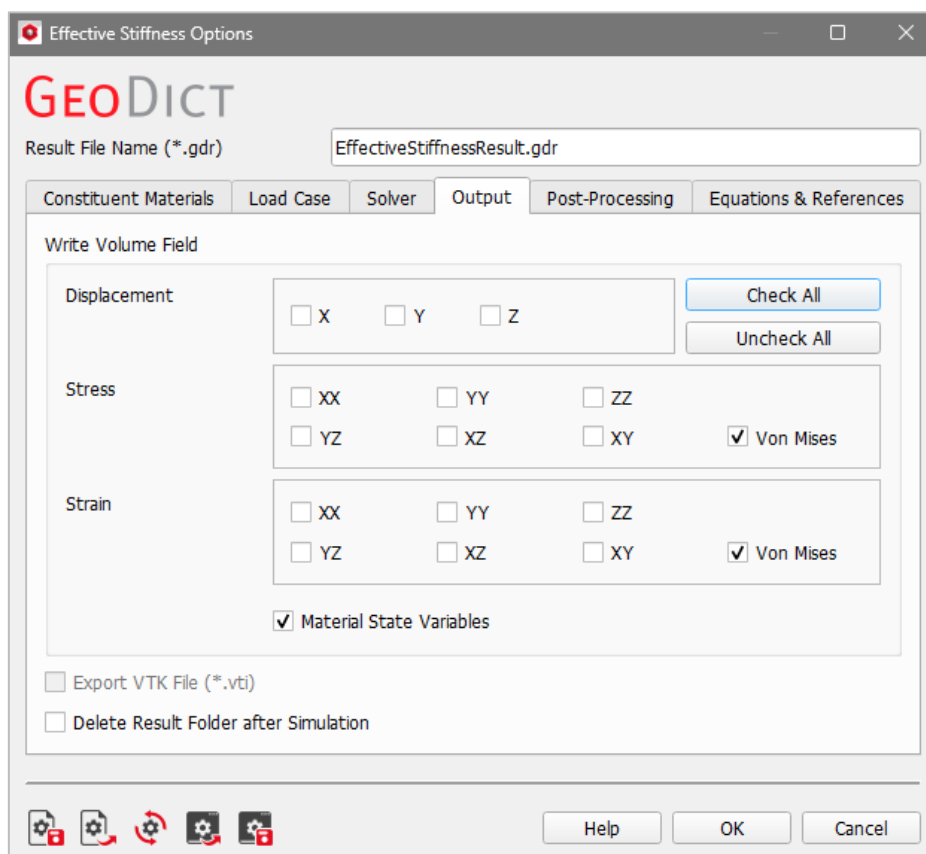

POST-PROCESSING

The options available under **Post-Processing** are optional and they can also be set later in the Result Viewer of the result file (*.gdr) after the computations.

The options in the **ElastoDict-Effective Stiffness** settings are shown here.

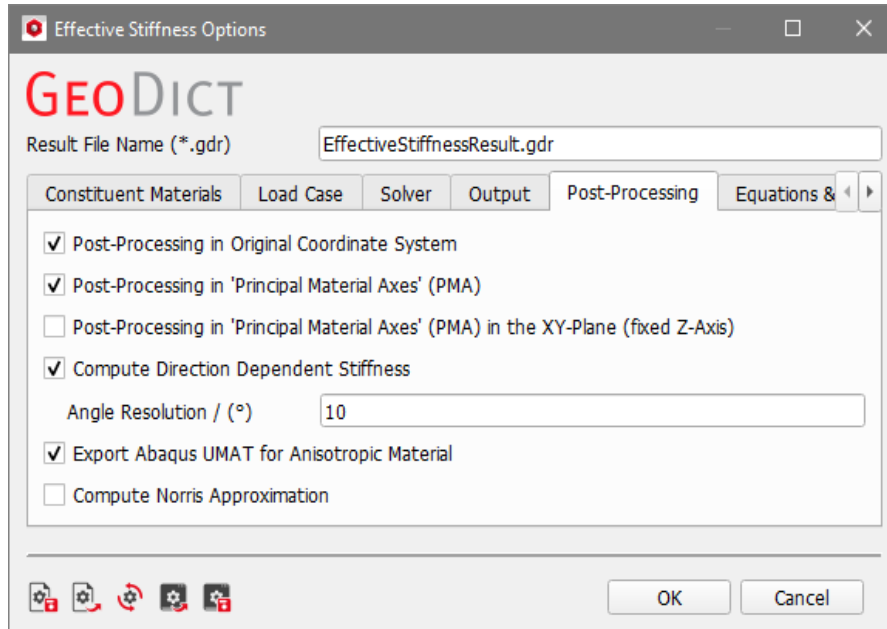

How they look in the Result Viewer is shown below. **Post-Processing in Original Coordinate System** is always available and selected by default. All other post-processing options are only available if all load directions (XX, YY, ZZ, YZ, XZ, and XY) have been previously checked under the **Load Case** tab.

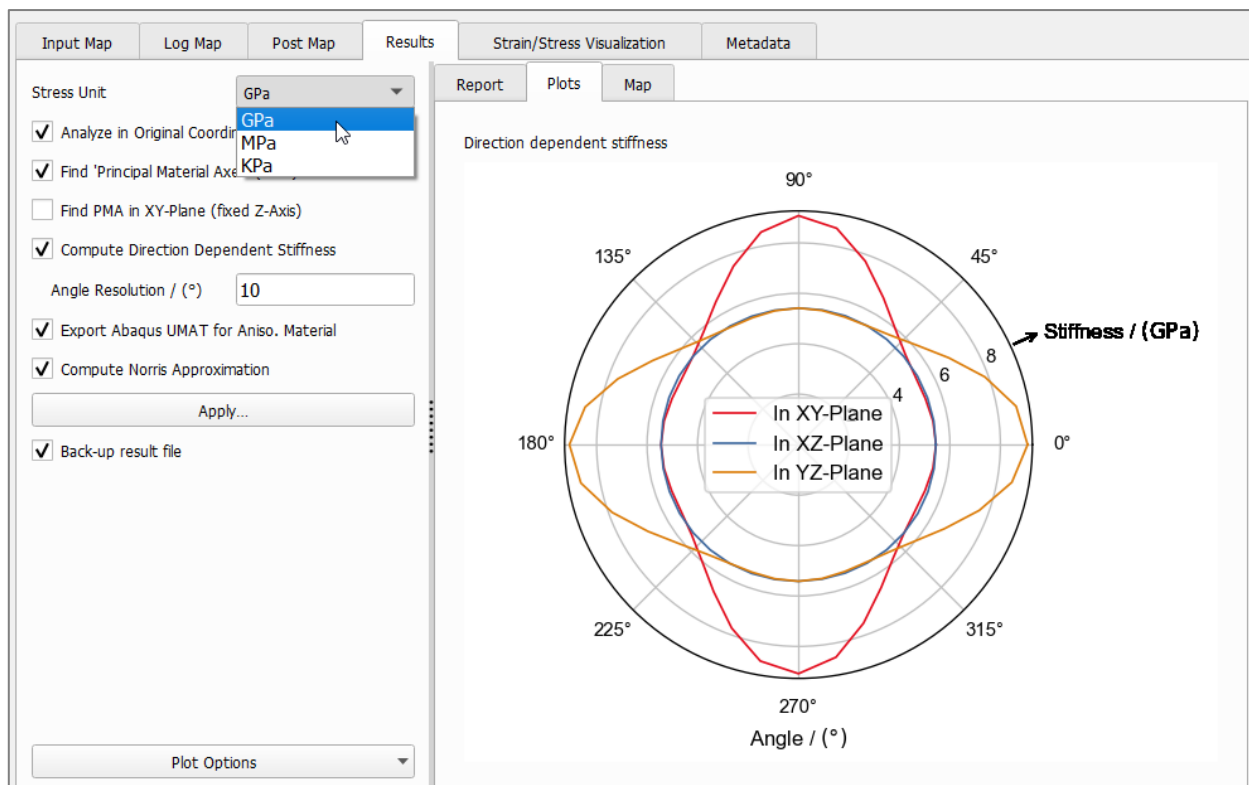

STRESS UNIT

When post-processing the plots in the Result Viewer, the **Stress Unit** for the results can be selected. This choice has an effect on the values under the Report subtab and on the Plots subtab. The stress unit in the Results – Map subtab is always GPa.

POST-PROCESSING IN ORIGINAL COORDINATE SYSTEM

Check **Post-Processing in Original Coordinate System** to compute the engineering parameters and elasticity-tensor approximations in the original coordinate system (X, Y, Z).

POST-PROCESSING IN PRINCIPAL MATERIAL AXES (PMA)

Check **Post-Processing in Principal Material Axes (PMA)** to find the PMA of the material and compute the engineering parameters and elasticity-tensor approximations in the PMA system. This is only possible if all six load cases (under **Load Case** tab) are calculated.

POST-PROCESSING IN PRINCIPAL MATERIAL AXES (PMA) IN THE XY-PLANE

Check **Post-Processing in Principal Material Axes (PMA) in the XY-plane** to find the PMA of the material in the XY-plane and to compute the engineering parameters and elasticity-tensor approximations in this PMA system. This is only possible if all six load cases (under **Load Case** tab) are calculated.

COMPUTE DIRECTION-DEPENDENT STIFFNESS

Check **Compute Direction-Dependent Stiffness** to calculate the material stiffness in the XY, XZ, and YZ plane, in the original coordinate system. Additionally, the material stiffness can be analyzed for arbitrary angles. With the **Angle Resolution (°)** setting the angle steps for this calculation is defined.

The result file obtained after computations includes a table showing the calculated Young's Modulus **E** in the three planes according to the entered angle resolution. Additionally, a plot for the direction dependent stiffness can be found in the results file under the **Plots** tab.

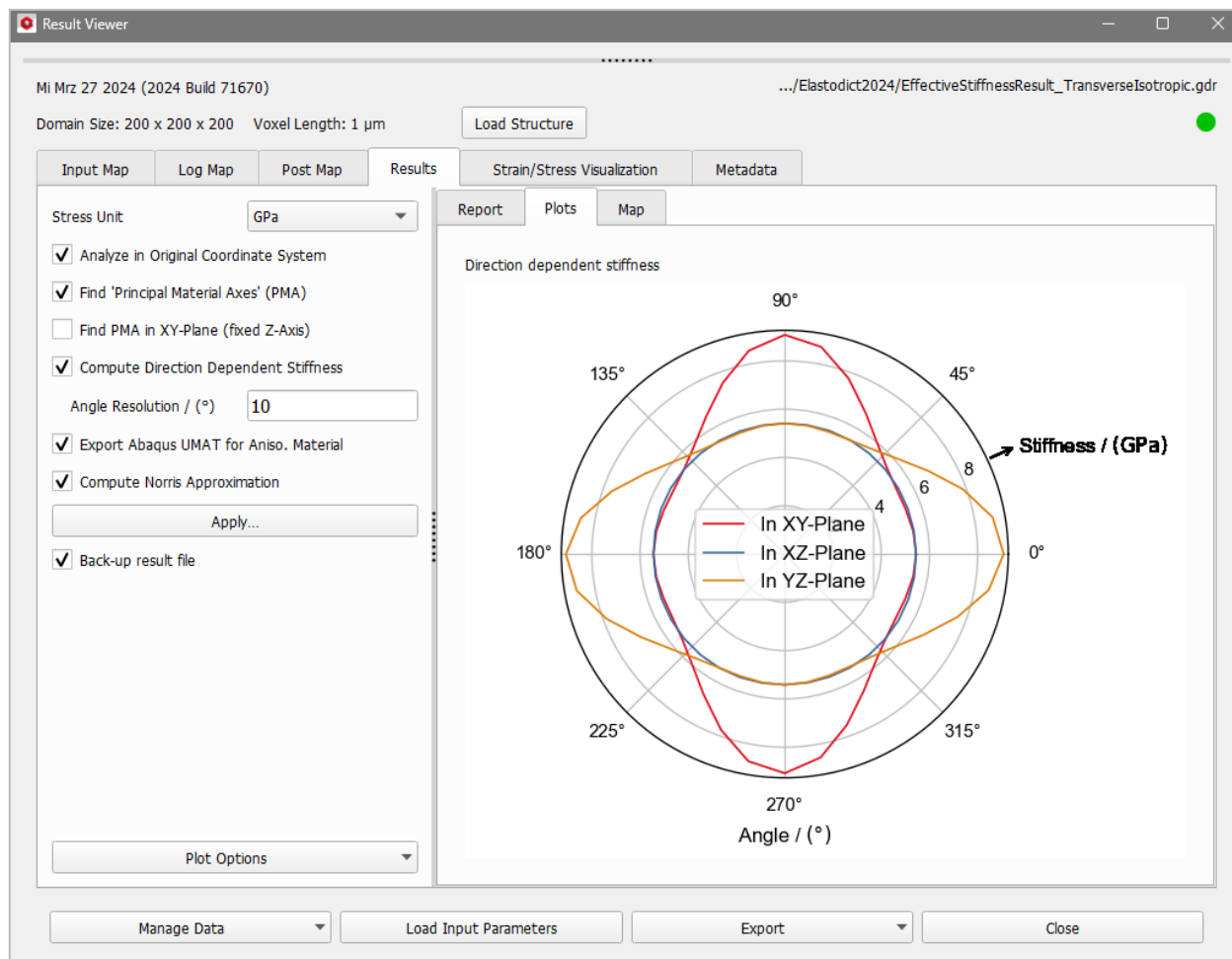

EXPORT ABAQUS UMAT FOR ANISOTROPIC MATERIAL

When Export Abaqus UMAT for Anisotropic Material, an UMAT with the computed anisotropic material properties is exported and can be found in the result folder. This UMAT can directly used in Abaqus, or it can also be used as material in **GeoDict**.

COMPUTE NORRIS APPROXIMATION

Check **Compute Norris Approximation** to compute the cubic elasticity tensor approximation following Norris (A. Norris, Elastic Moduli Approximation, J. Acoust. Soc. Am. Vol 119, No 4, April 2006). See also the section about the effective elastic properties in the Appendix on pages [130](#) ff. This is only possible if all six load cases (under **Load Case** tab) are calculated.

EQUATIONS & REFERENCES

The differential equations solved in the simulation are listed under the **Equations & References**. Additionally, the tab contains the references for the methods used by the FeelMath solver in **ElastoDict** (see page [1](#) for links).

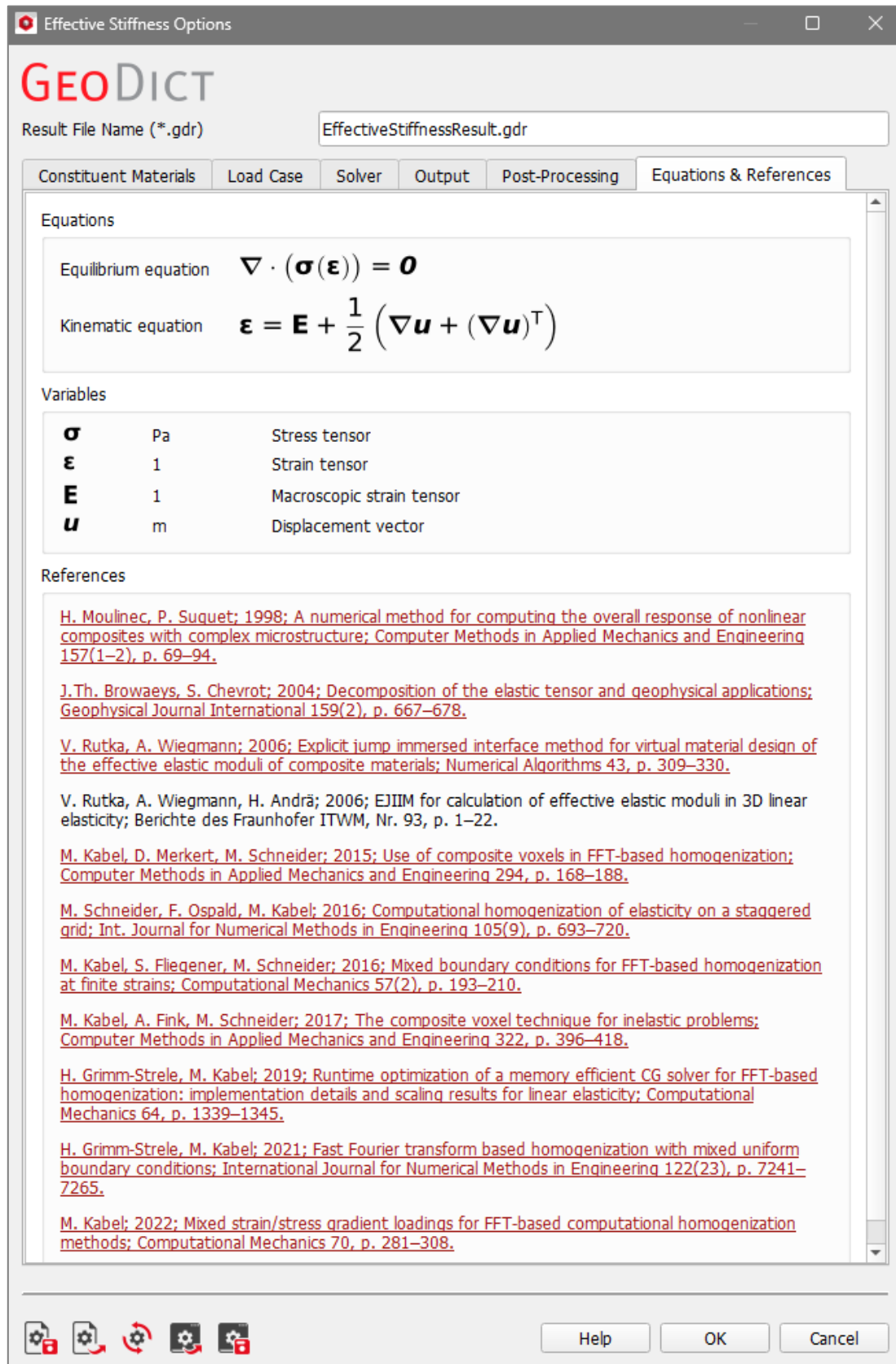

RESULT FILE (.GDR)

The handling of the result file works analogous as for **ElastoDict-Deformations** (see page 37), therefore only the features specific for **ElastoDict-Effective Stiffness** are explained here in detail.

Clicking **Load Structure** in the result file loads the original structure to the visualization area.

RESULTS

The **Results** tab gives access to the computed values for the parameters calculated by the selected **ElastoDict** process. The **Results** tab contains two or three subtabs:

- The **Report** subtab shows the values of the computed mechanical properties. These values can be exported in various ways by selecting an option from the **Export** pull-down menu at the bottom of the Result Viewer, see page 38 for more details.

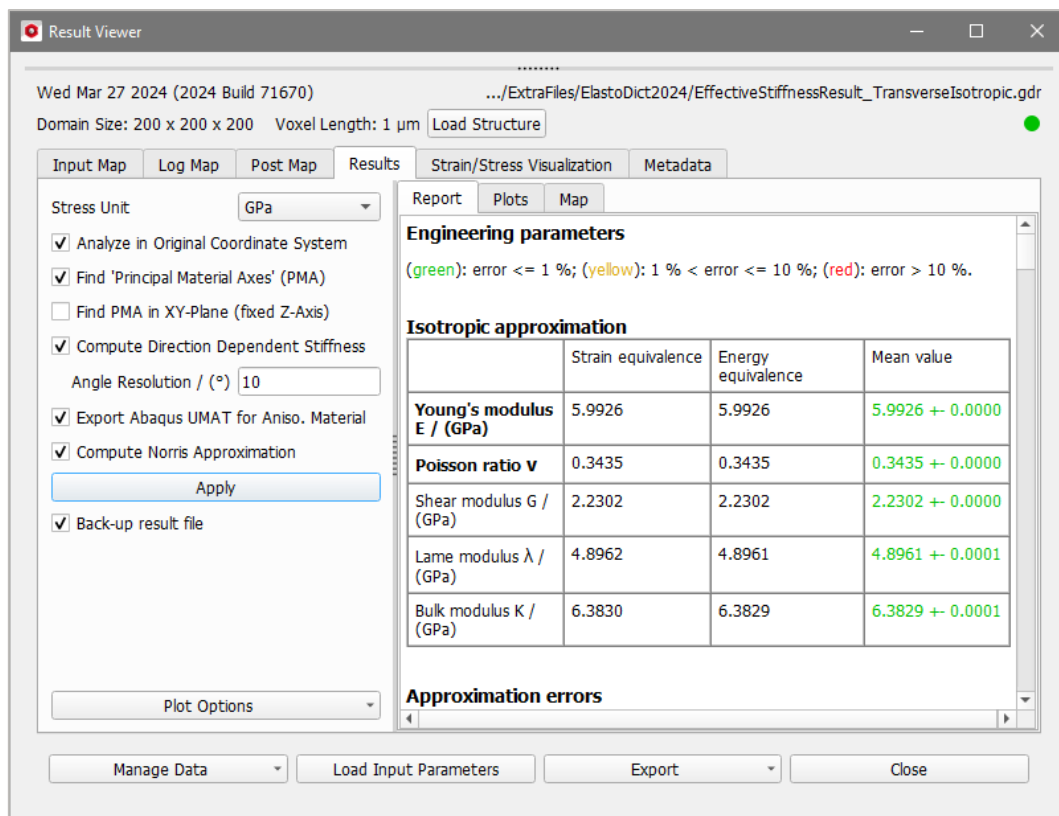

For **ElastoDict-Effective Stiffness (AF)** and **ElastoDict-Effective Stiffness**, if all 6 load cases have been computed, an analysis of the effective stiffness tensors can be carried out on the tables shown in this view. This analysis allows to judge, whether the material exhibits some degree of symmetry, such as transverse isotropy.

- In the **ElastoDict-Effective Stiffness** result file, the **Plots** subtab shows a plot of the direction dependent stiffness in the X-, Y- and Z-planes (see page 66 for further explanation). Right-clicking on the plot view allows generating an image or exporting the values as .txt file or save the image as .png file.
- The **Map** subtab shows a structured list of all result values.

If only the stiffness in one direction is computed instead of the complete stiffness tensor (by selecting e.g. **Stiffness in X-Direction** as **Stiffness Mode** under the **Load Case** tab), the results report is much simpler. It contains only the Young's modulus in the selected direction, and the average strain and the average stress in the structure (see example below).

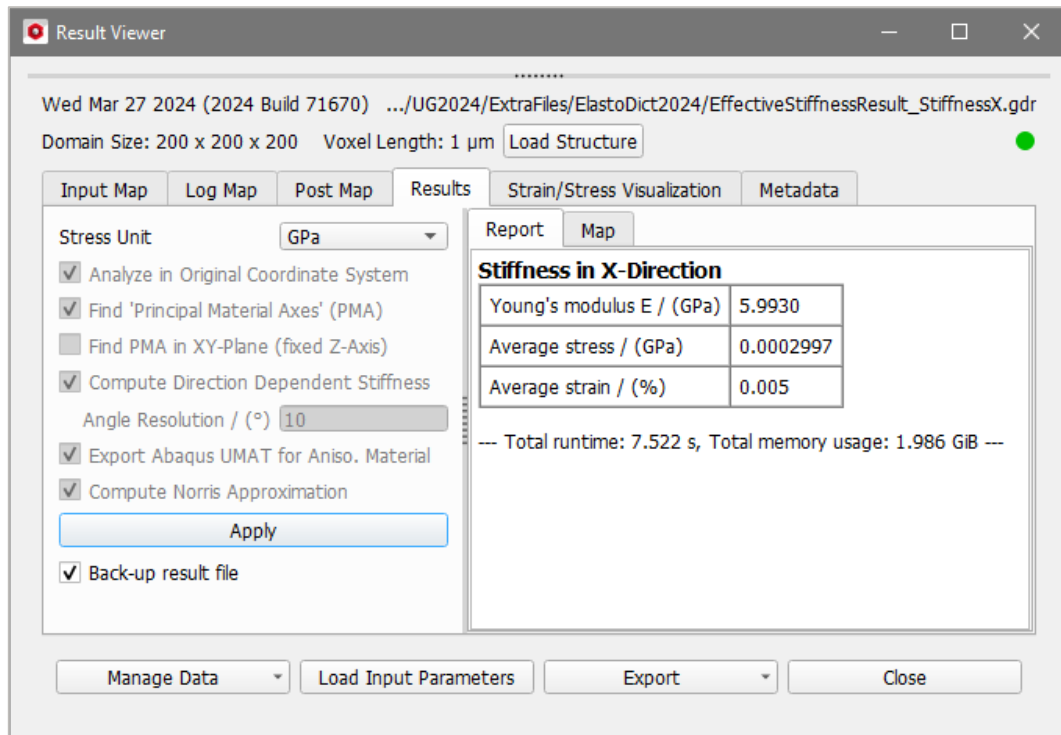

STRAIN/STRESS VISUALIZATION

In the **Visualization** tab, the computed solution volume fields (*.das) and visualizations of the principal material axes (PMA) can be loaded.

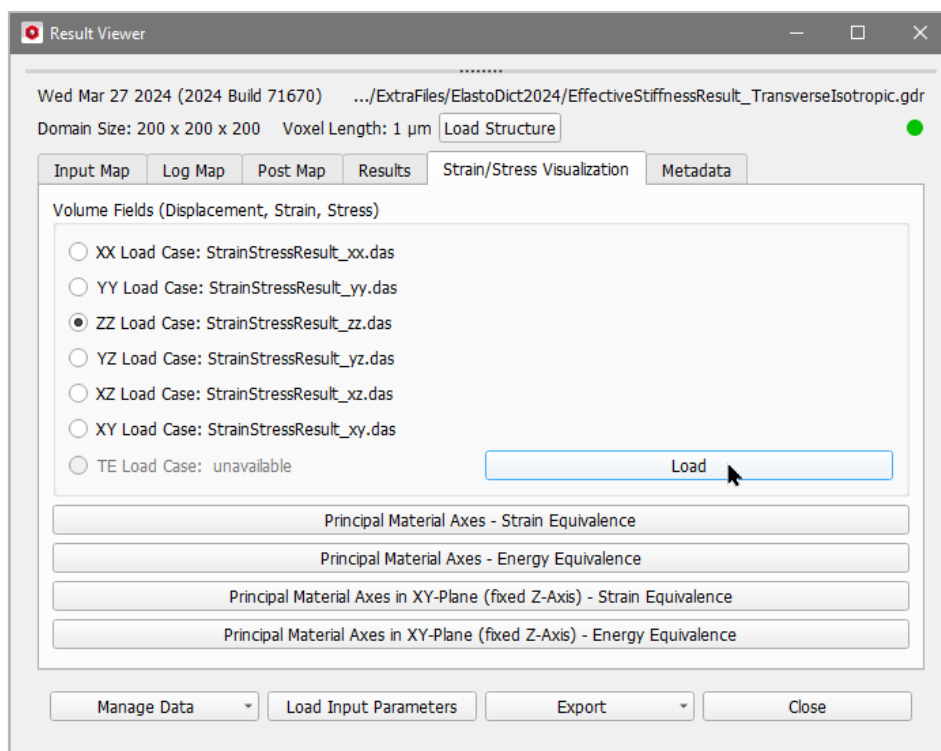

See an example of the possibilities of visualizing the results from **ElastoDict**-Effective Stiffness on page [85ff.](#) and an example on visualizations of the principal material axes (PMA) on pages [93ff.](#)

BENCHMARK RESULTS FOR EFFECTIVE STIFFNESS

For the weave structure shown here, the effective stiffness is computed with **ElastoDict**-Effective Stiffness and the FeelMath solver. All fibers are fully resolved in the structure of 2,590 x 2,590 x 821 voxels (i.e., in total ~5.5 billion voxels).

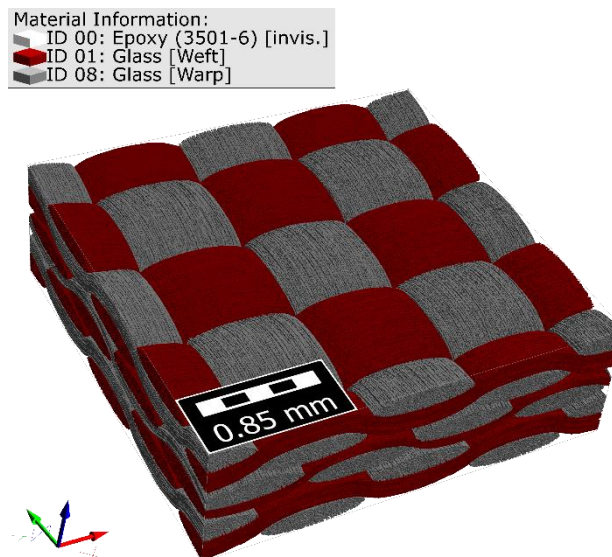

For strain load type and periodic boundary conditions, all six load cases are computed using the conjugate gradient method.

The computation was run on our server, with 2 x Intel E5-2697A v4 processors with 16 cores each, running with a maximum of 3.60 GHz, and 1024 GB RAM.

To show the possible benefit of using downsampling, runtime and memory requirements are compared with and without downsampling, for a different number of processes, using **GeoDict** 2024 (r717123).

Runtime results are shown in the following figure. The computation, which needs 40 h with 8 processes, can be run in 31 min with 32 processes and downsampling. Even without increasing the number of processes, the runtime is reduced by 97 %.

The memory requirement is reduced by 97 % as well. The computation that needed 1 TB of RAM without downsampling requires only 28 GB with downsampling and thus can be run on a standard laptop or desktop computer.

The ideal speedup, i.e., getting half the runtime for twice the number of processes is also shown in the figure for the computation with downsampling. Computations with FeelMath have a very good speedup compared to the ideal line.

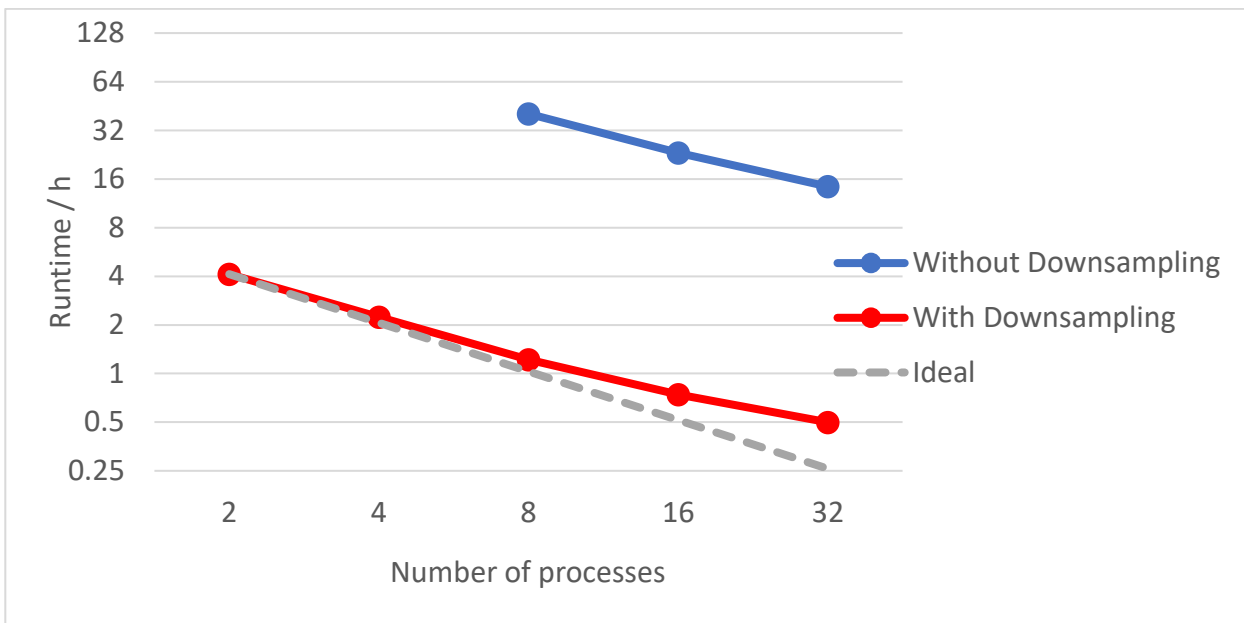

EFFECTIVE STIFFNESS (AF)

The FeelMath-AF solver provides a fast analytic approximation of the effective elastic properties. It computes the **Voigt** (upper bound), the **Reuss** (lower bound) and the **Mori-Tanaka** approximations. AF stands for analytic functions, since here the equations are solved by an analytic approximation instead by an iterative numerical solver.

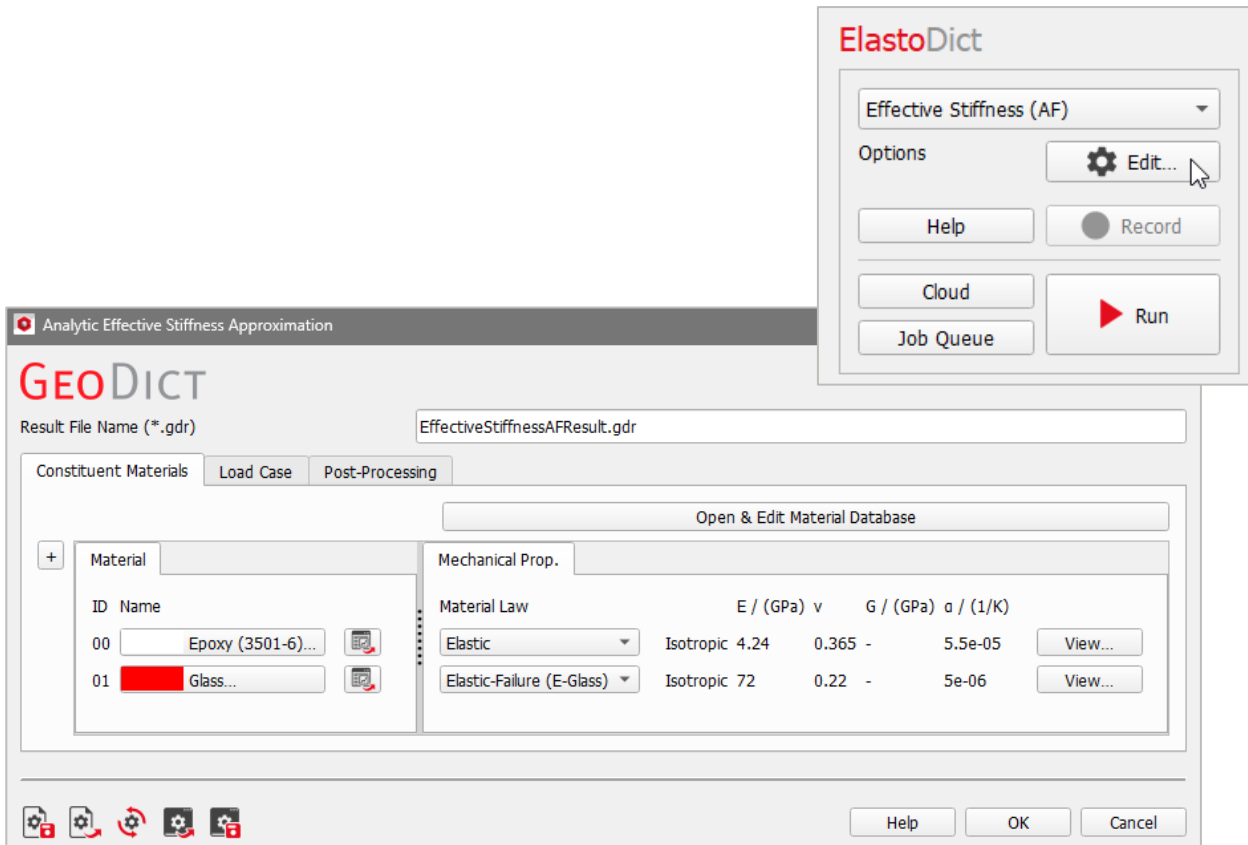

ElastoDict-Effective Stiffness (AF) only works for linear elastic materials.

CONSTITUENT MATERIALS

Select the constituent materials of the structure model as indicated above on page [11](#) for **ElastoDict-Deformations**. As mentioned above, **ElastoDict-Effective Stiffness (AF)** only works for linear materials. Choosing nonlinear materials results in an error message when starting the solver.

LOAD CASE

The **Voigt** and **Reuss** approximations can be interpreted as the ratio of average stress and average strain within the microstructure. The stress and strain are generally unknown and expected to be non-uniform.

The upper bound (**Voigt**) assumes that the strain is uniform everywhere. The lower bound (**Reuss**) assumes that the stress is uniform everywhere. The **Mori-Tanaka** approximation works for Ellipsoids and circular fibers and needs the input of analytic data (*.gad files).

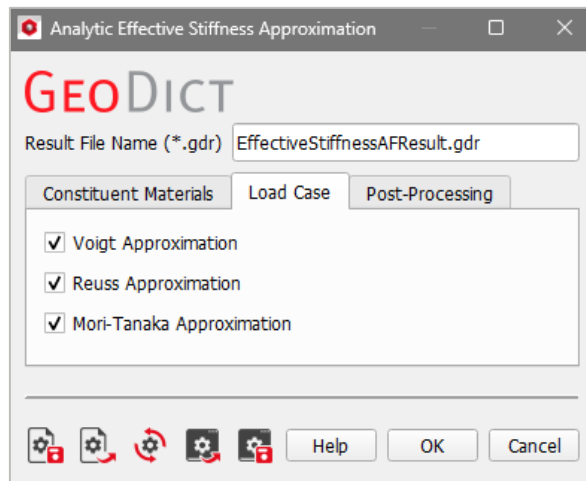

POST-PROCESSING

Analogous to **ElastoDict-Effective Stiffness**, the post-processing options can also be chosen after the computation in the Result Viewer. For **ElastoDict-Effective Stiffness (AF)**, only the option **Compute Direction Dependent Stiffness**, and the option to set a corresponding **Angle Resolution** is available. Refer to page [66](#) in the **ElastoDict-Effective Stiffness** section for further details.

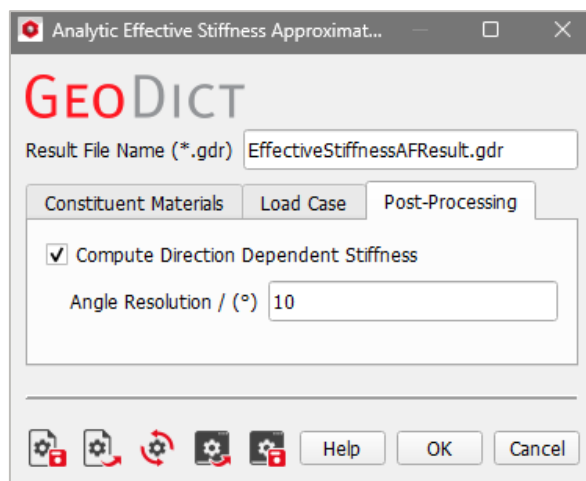

RESULT FILE (.GDR)

The handling of the result file is analogous to that of the **ElastoDict-Deformations** (see page [37](#)). Therefore, only the features specific for **ElastoDict-Effective Stiffness (AF)** are explained here in detail.

RESULTS

The **Results** tab gives access to the computed values for the parameters calculated by the selected **ElastoDict** process. The **Results** tab is divided into two or three subtabs:

- The **Report** subtab shows the values of the computed mechanical properties. These values can be exported in various ways by selecting an option from the

Export pull-down menu at the bottom of the Result Viewer, see page 38 for more details.

An analysis of the effective stiffness tensors can be carried out on the tables shown. This analysis allows to judge, whether the material exhibits some degree of symmetry, such as transverse isotropy.

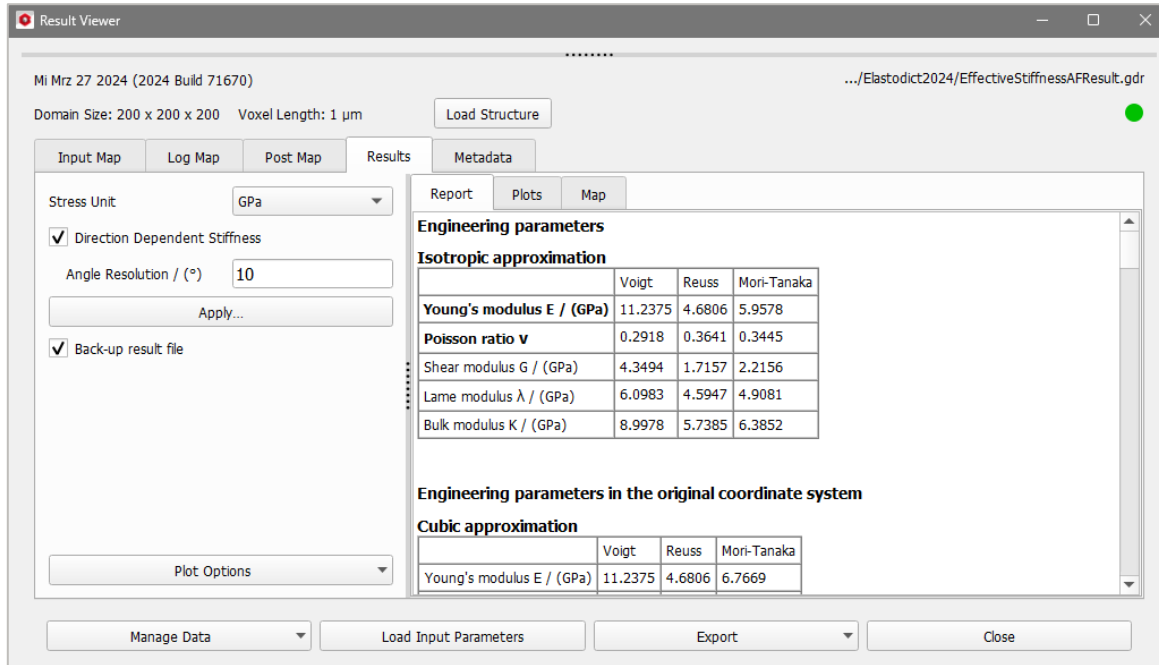

- The **Plots** subtab shows a plot of the direction dependent Mori-Tanaka stiffness in the X-, Y- and Z-planes as well as the **Voigt** (upper bound) and the **Reuss** (lower bound) approximations.

Right-clicking on the plot view allows generating an image or exporting the values as .txt file.

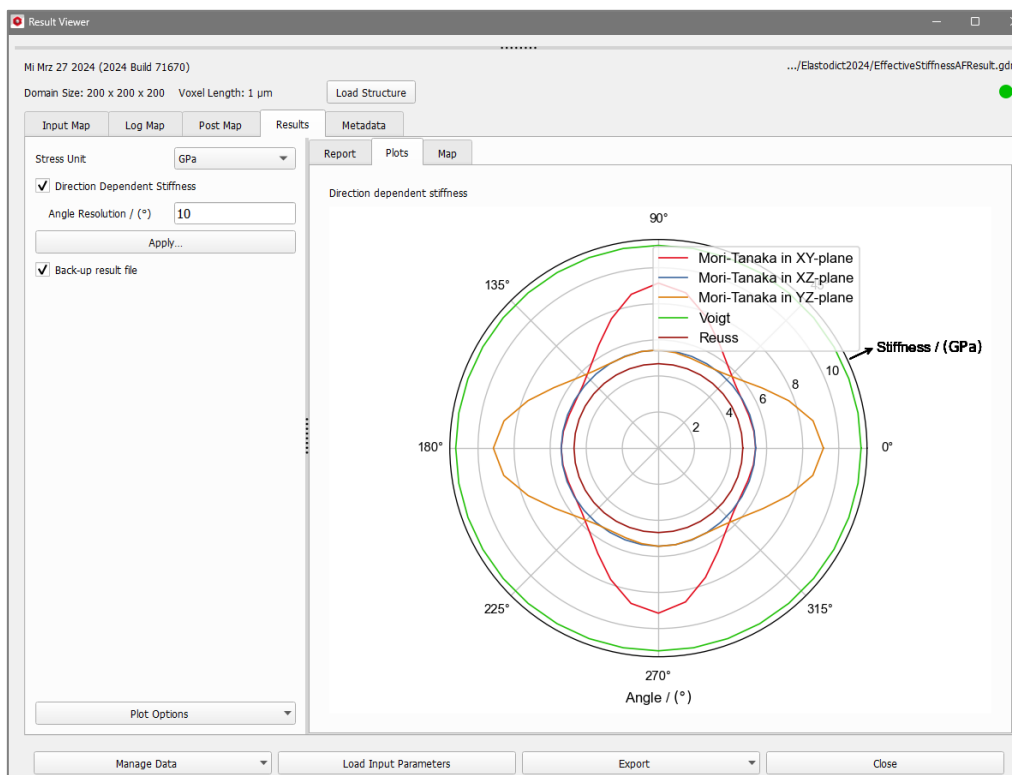

- The **Map** subtab shows a structured list of all result values.

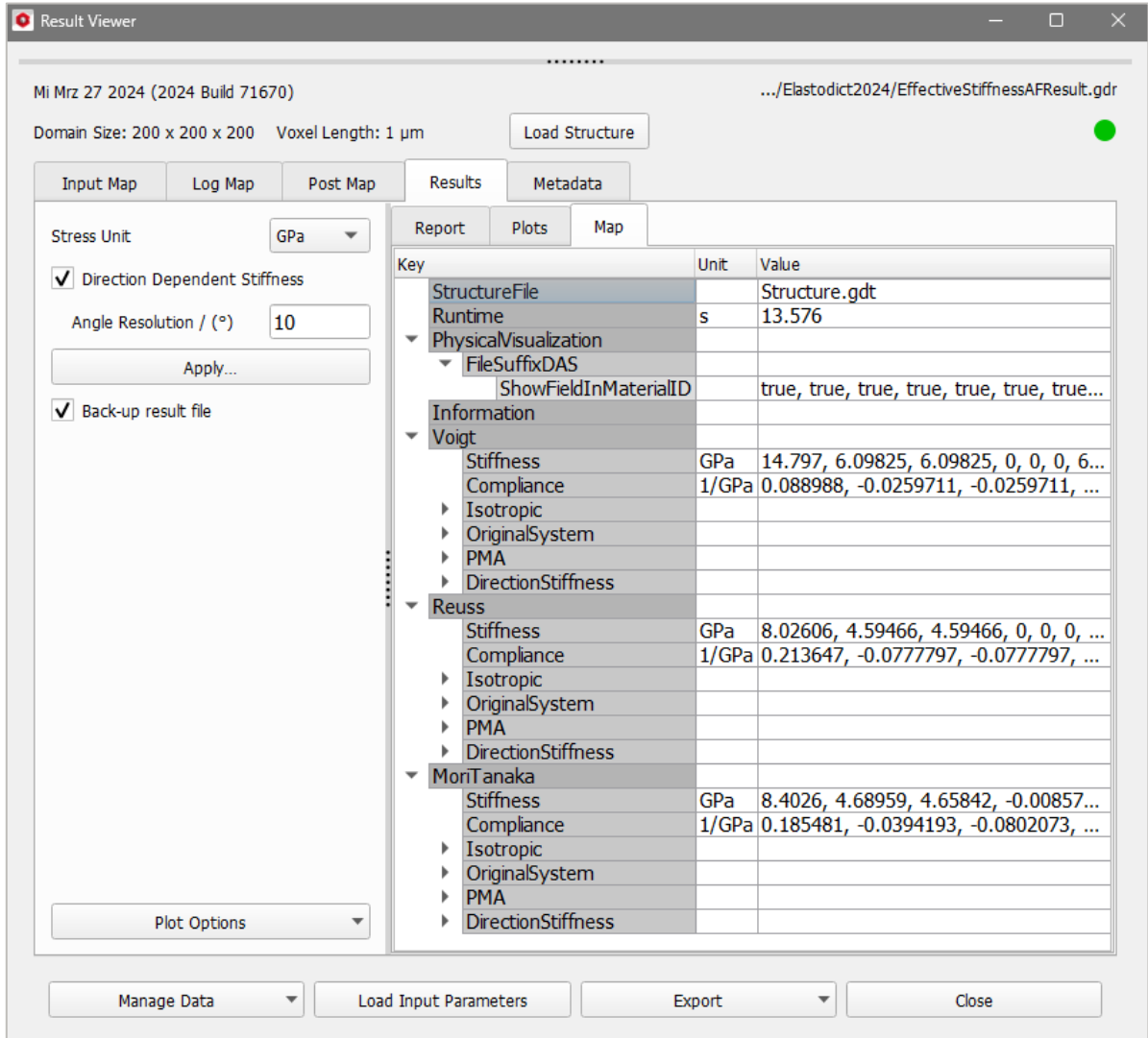

MECHANICS GEOAPPS

GeoDict offers great automation possibilities to enhance productivity in the form of GeoApps. All steps done by the user in GeoDict are recorded in macros. The **GeoApp** dropdown menu in GeoDict gives access to several pre-defined macros for workflows that are often requested.

There are two possibilities to access the GeoApps for ElastoDict.

One way is to choose **GeoApp** → **Modules** → **Mechanics GeoApps** in the GeoDict main GUI. With this option, the ElastoDict section in the main GUI changes to **Mechanics GeoApps**. The two available mechanics GeoApps are chosen from the dropdown menu.

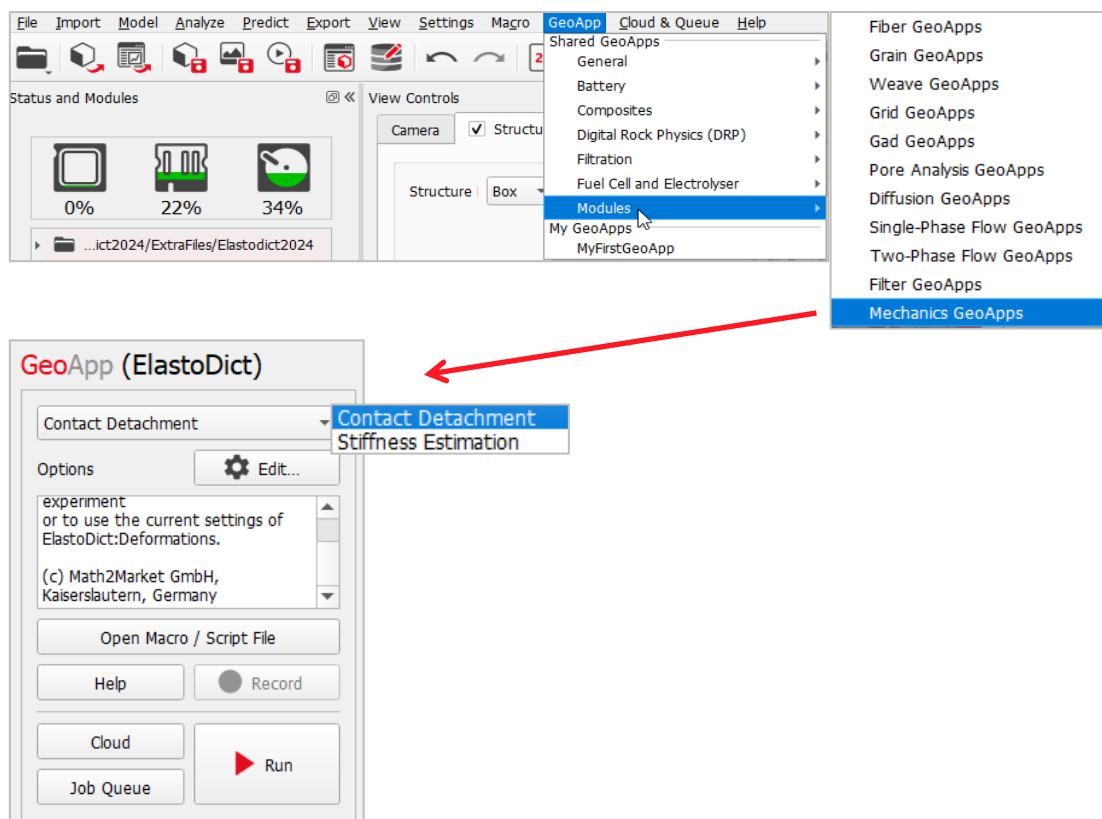

Another possibility is to choose a **Mechanics GeoApps** directly as one of the options in the ElastoDict section of the main GeoDict GUI.

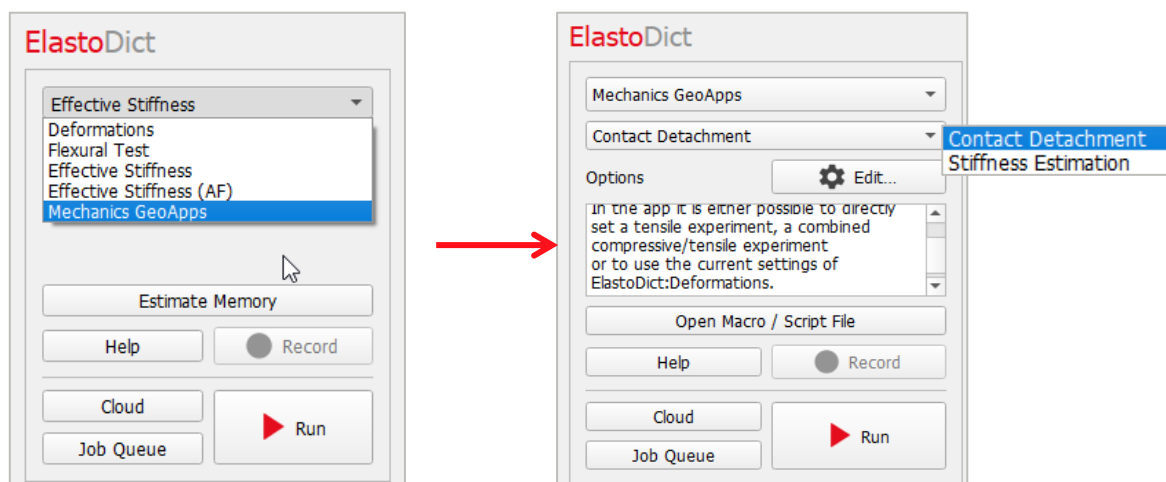

When **Mechanics GeoApps** is chosen in the module section, two representative calculations are available – **Contact Detachment** and **Stiffness Estimation**.

Choosing one of them allows the user to start a simulation much easier since only specific parameters need to be set. By clicking on **Edit...** a parameter dialog opens, which contains all relevant parameters and solver settings for each simulation in a simplified and straightforward way.

For more information on **GeoApps** in general, refer to the [GeoApps for GeoDict handbook](#).

CONTACT DETACHMENT

This **GeoApp** allows to use the early access version of the contact detachment feature introduced with **GeoDict 2024**. With this feature, it is possible to simulate detaching of contacts between objects in **ElastoDict Deformations** simulations.

By clicking **Edit...** in the **ElastoDict** section of the main **GeoDict** GUI, the **Contact Detachment Parameters** dialog opens.

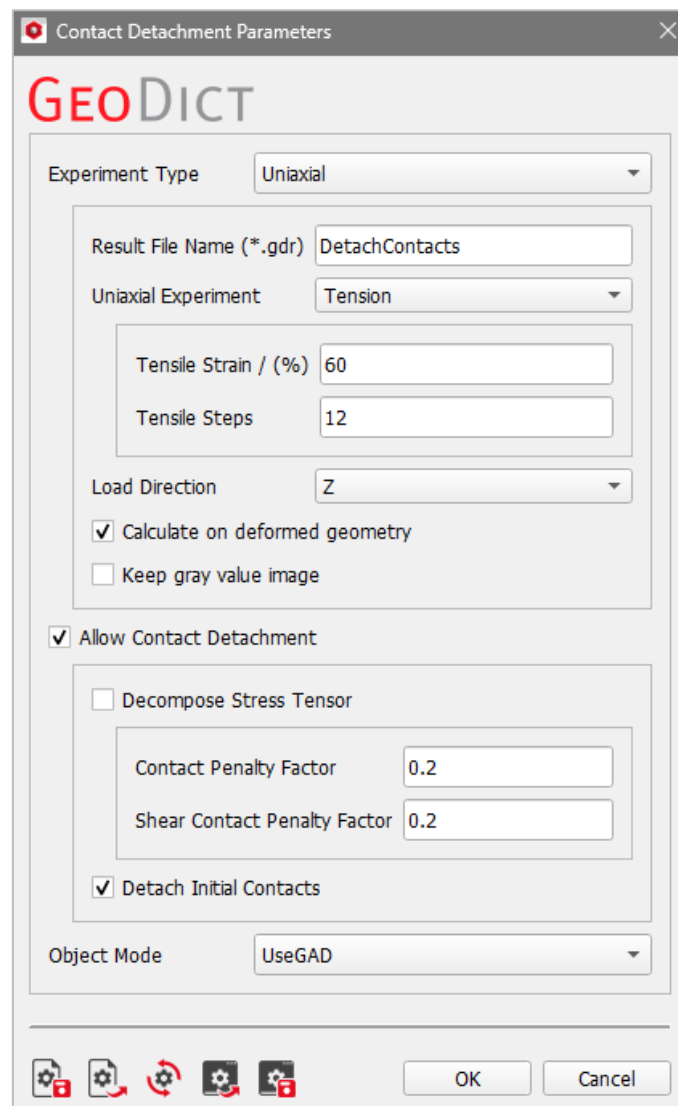

EXPERIMENT TYPE

In the **GeoApp** it is either possible to directly set a tensile experiment, a combined compressive/tensile experiment, or to use the current settings of **ElastoDict Deformations**.

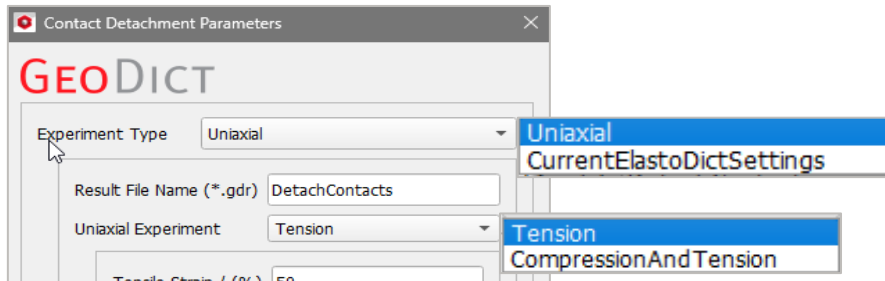

The tensile experiment is chosen by selecting **Tension** in the dropdown menu. The experiment is defined by the maximal tensile strain (in percentage with respect to the original geometry) and the number of steps to apply this strain.

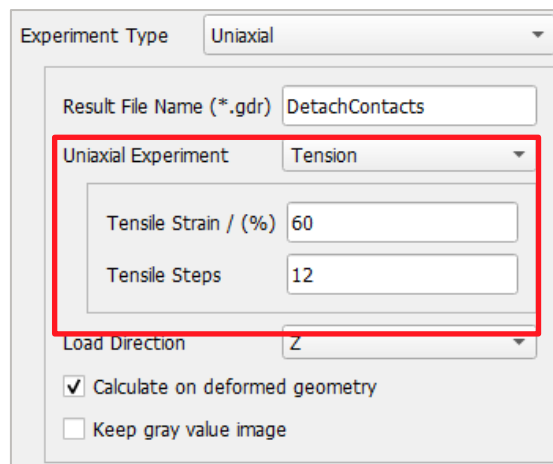

For the **Compression and Tension** experiment, a compression is applied to the geometry, followed by a tension. Again, both deformations are defined by the maximal strain (in percentage with respect to the original geometry) and the number of steps for each deformation.

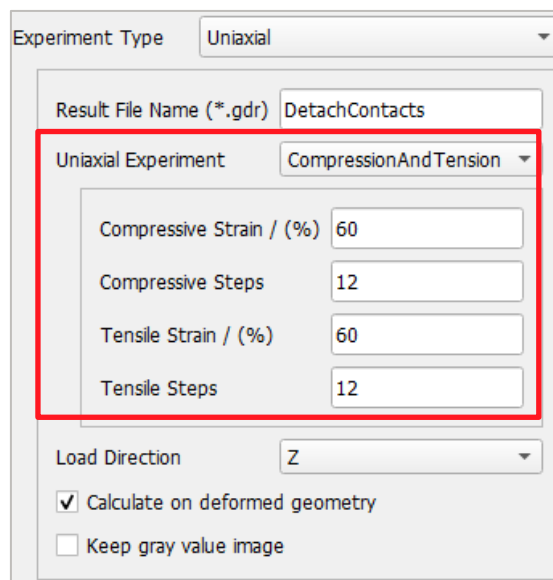

For both experiments the **Load Direction** can be chosen (X, Y or Z) and whether the load steps shall be applied on deformed geometry, which is the case if **Calculate on deformed geometry** is checked. The latter should always be selected for the **DetachContacts** **GeoApp**.

To keep the accurate volume fraction information for each material ID and update these in the memory, the **Keep gray value image** checkbox can be chosen. This option needs more memory, but leads to more accurate geometry deformation if many (small steps) are computed. If this option is not chosen the volume fractions are segmented into a structure in each deformation step and the volume fraction information is lost.

If **CurrentElastoDictSettings** is chosen, the settings, which were defined in the **ElastoDict Deformations** dialog, are taken over and used with the **GeoApp**. No additional adjustments can be made in this **GeoApp** dialog.

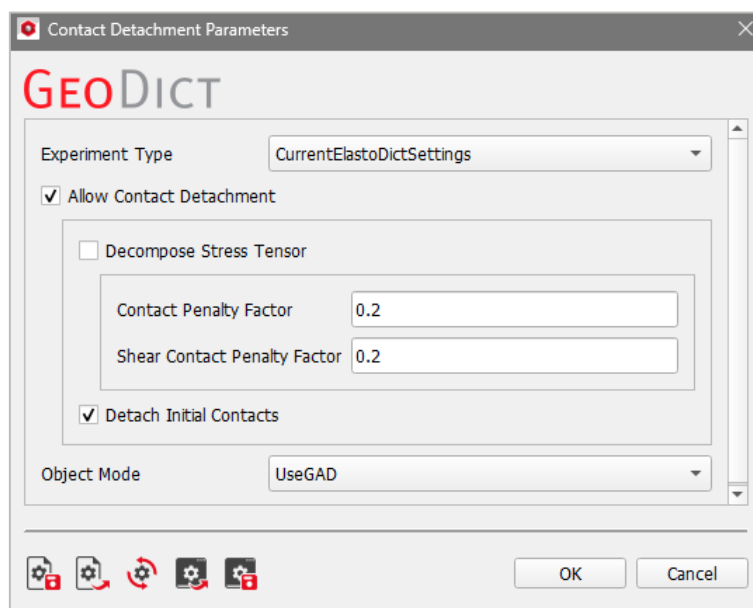

ALLOW CONTACT DETACHMENT

If the option **Allow Contact Detachment** is checked, a detachment between different objects during the simulation run is possible.

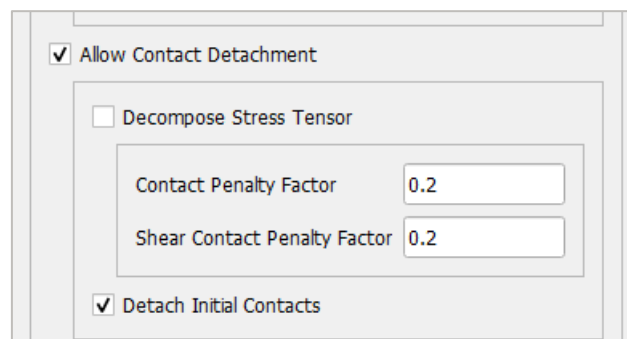

If **Decompose Stress Tensor** is chosen, detachment is detected as soon as the stress changes from compression to tension in the contact area of two objects. With the Contact Penalty Factor the detachment can be controlled. The higher the penalty factor, the later the detachment. As this option is still work in progress and the adjustment of the penalty factor highly dependent on the structure settings, it is recommended to leave this option unchecked.

By choosing **Detach Initial Contacts**, a detachment is allowed for all objects, especially also for those, which are attached to each other initially. Otherwise, only objects can be detached, which were detached initially but get attached to each other during the simulation.

OBJECT MODE

For this simulation, information about the objects in the structure is required, either in the form of GAD objects (choose **Object Mode** → **UseGad**) or via a G32 file, which can be loaded by choosing **Object Mode** → **LoadFile**.

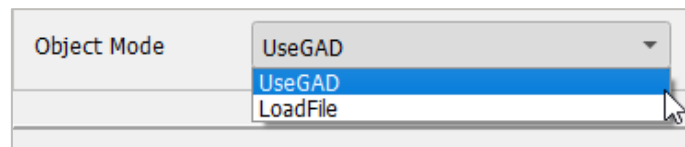

RESULT FILE (*.GDR)

After closing the **Contact Detachment Parameter** dialog by clicking on **OK**, the Contact Detachment simulation is started by clicking **Run**. The results are stored in the result file previously entered in **Result File Name (*.gdr)** of the **Contact Detachment Parameters** dialog.

After a successful run, the **Result Viewer** opens automatically at the **Results - Report** subtab.

The screenshot shows the 'Result Viewer' window. At the top, it displays 'Do Mrz 28 2024 (2024 Build 71670)' and the file path '.../Elastodict2024/DetachContacts.gdr'. Below this, it shows 'Domain Size: 64 x 64 x 64' and 'Voxel Length: 250 nm'. The 'Results' tab is active, showing a table of 'Average strain' and 'Average stress' data over time.

Coordinate system
The coordinate system of the experiment is aligned with the coordinate axis in GeoDict.

Average strain

Time / (s)	Temp. Change / (°C)	XX / (%)	YY / (%)	ZZ / (%)	YZ / (%)	XZ / (%)	XY / (%)	VonMises / (%)	Hydrostatic / (%)
0	0	0	0	0	0	0	0	0	0
1	0	-0.40091	-0.40091	5	-0.012934	-0.012934	0.0062058	5.40101	1.39939
2	0	-0.75101	-0.75101	10	-0.040552	-0.040552	0.012515	10.7515	2.83266
3	0	-1.0364	-1.0364	15	-0.029882	-0.029882	0.018236	16.0366	4.30909
4	0	-1.2494	-1.2494	20	-0.071	-0.071	0.023204	21.2502	5.83371
5	0	-1.4397	-1.4397	25	-0.087326	-0.087326	0.027174	26.4406	7.37351
6	0	-1.5872	-1.5872	30	-0.10976	-0.10976	0.031939	31.5884	8.94186
7	0	-1.6892	-1.6892	35	-0.18286	-0.18286	0.035541	36.692	10.5405
8	0	-1.7783	-1.7783	40	-0.25051	-0.25051	0.038977	41.7828	12.1478
9	0	-1.91	-1.91	45	-0.12766	-0.12766	0.04187	46.9111	13.7267
10	0	-2.0872	-2.0872	50	-0.020233	-0.020233	0.046973	52.0873	15.2752
11	0	-2.2879	-2.2879	55	0.070549	0.070549	0.052788	57.2882	16.8081
12	0	-2.4853	-2.4853	60	0.14763	0.14763	0.058575	62.4864	18.3432

Average stress

Time / (s)	Temp. Change / (°C)	XX / (GPa)	YY / (GPa)	ZZ / (GPa)	YZ / (GPa)	XZ / (GPa)	XY / (GPa)	VonMises / (GPa)	Hydrostatic / (GPa)
0	0	0	0	0	0	0	0	0	0
1	0	-0.0008683	-0.0008683	0.50281	-0.0001519	-0.0001519	6.3086e-05	0.503679	0.167025

At the bottom of the window, there are buttons for 'Manage Data', 'Load Input Parameters', 'Export', and 'Close'.

In this example, a **Tension** experiment is simulated in which two objects were pulled in the Z-direction resulting in an object detachment. In the Report tab of the Result Viewer, the strain, which the objects undergo, is documented in the first table. As the **Uniaxial Experiment – Tensile** with a maximum of 60% strain was defined in the **Macroscopic Load** tab, the values for the Average strain for the column ZZ start with 0% and end in 60% after 12 steps.

In the table below, the **Average stress** is displayed.

The figure in the **Plots** subtab of the **Results** tab shows the tensile stress plotted over the tensile strain (which is the graphical representation of the table content of the Report tab). The tensile stress has its maximum for 20% strain and becomes zero at about 55% strain. At this point the separation of the two objects begins.

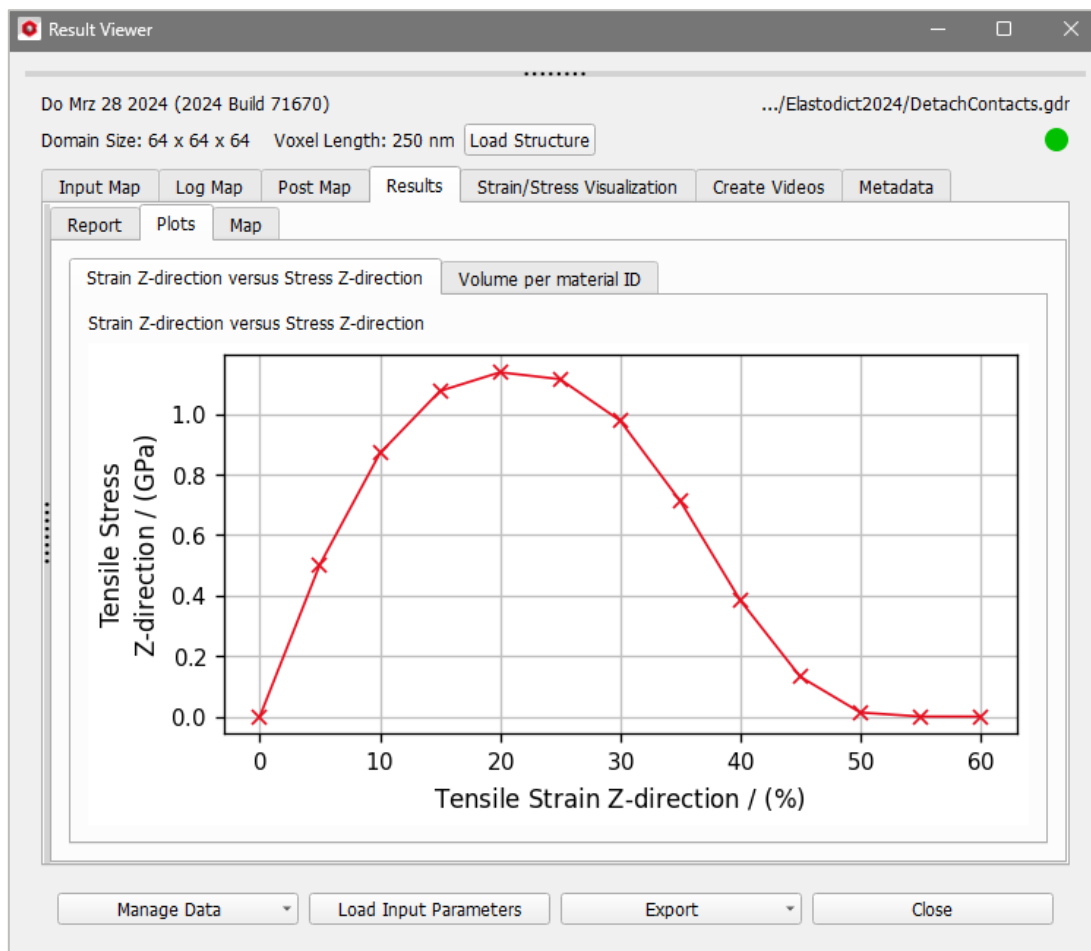

In the **Strain/Stress Visualization** tab, the different result files can be loaded according to the description on page [42](#).

Loading the Deformed Geometry (*.gdt) for **Time Steps 1, 4, 7 and 10**, for example, results in the four visualizations seen below in the **GeoDict** GUI.

For this type of experiment, the Box Structure Rendering might be the better choice (as in the pictures below) since the detachment can be seen more precisely.

Of course, the detachment process can be visualized in a video using options found under the **Create Videos** tab. See details in page [46](#).

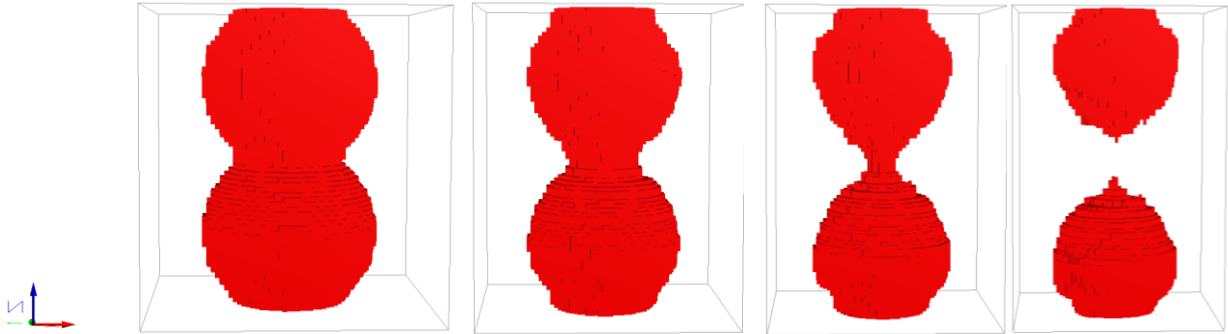

STIFFNESS ESTIMATION

This **GeoApp** estimates the stiffness for one constituent material, if the stiffness of the complete structure is known.

By clicking **Edit...** in the **ElastoDict** section of the main **GeoDict** GUI, the **Stiffness Estimation Parameters** dialog opens.

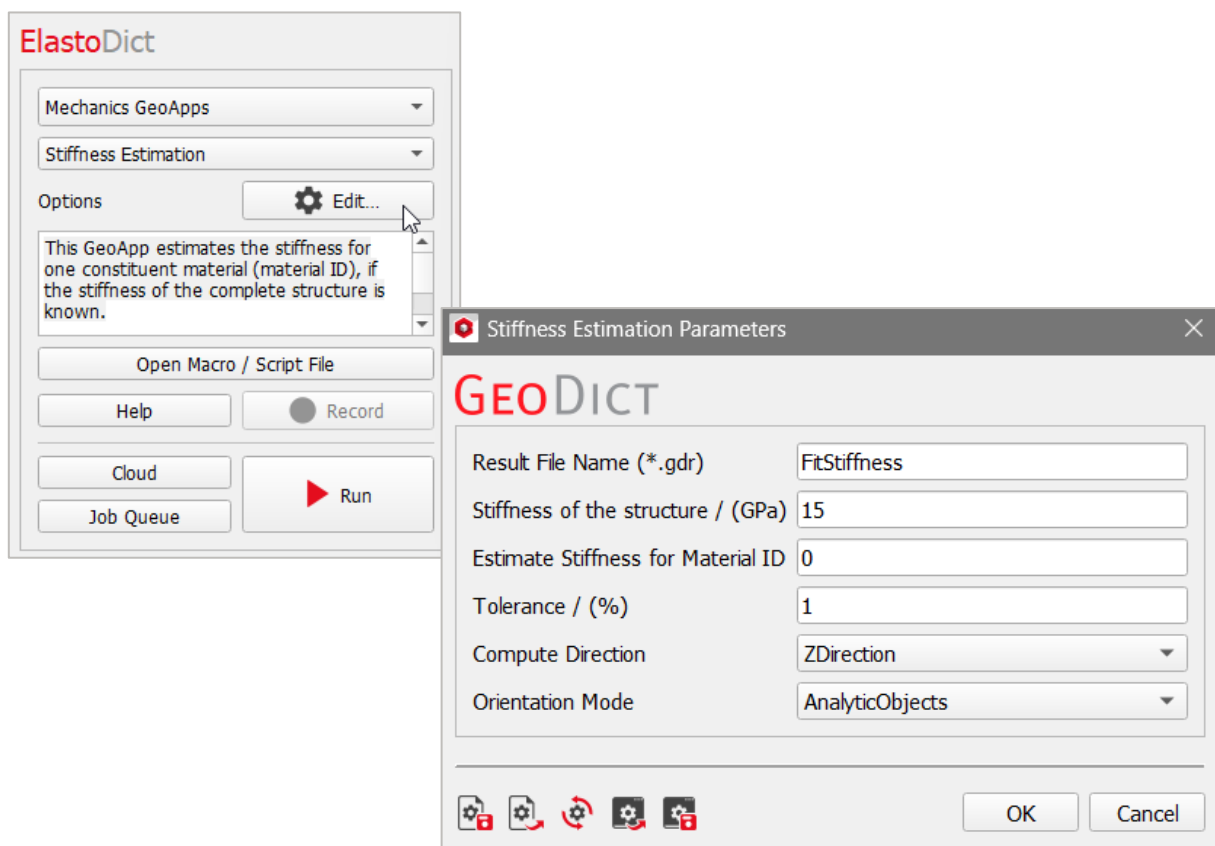

The result file name can be entered in **Result File Name (*.gdr)**.

The target stiffness of the structure is set in **Stiffness of the structure / (GPa)**.

Enter the ID number of the material for which the stiffness should be estimated in **Estimate Stiffness for Material ID**.

The stopping criteria is defined in **Tolerance / (%)**. If the relative error for the estimated structure stiffness is smaller than the specified tolerance, the estimation stops.

Finally, the **Compute Direction** (X, Y or Z) for the stiffness and the **Orientation Mode** are defined in their drop-down menus. Refer to page 32 for more details. In this example, the stiffness in Z-Direction of material with ID 01 is estimated.

After all parameters are set, clicking **OK** closes the **Stiffness Estimation Parameters** dialog and the estimation is started by clicking **Run**.

The estimation result is documented among others in the **Results** tab of the **Result Viewer**. The table shown in the Report tab summarizes the **GeoApp** results: besides the target of the structure stiffness, which is defined by the user, the stiffness, which is reached in the fitting process, is shown.

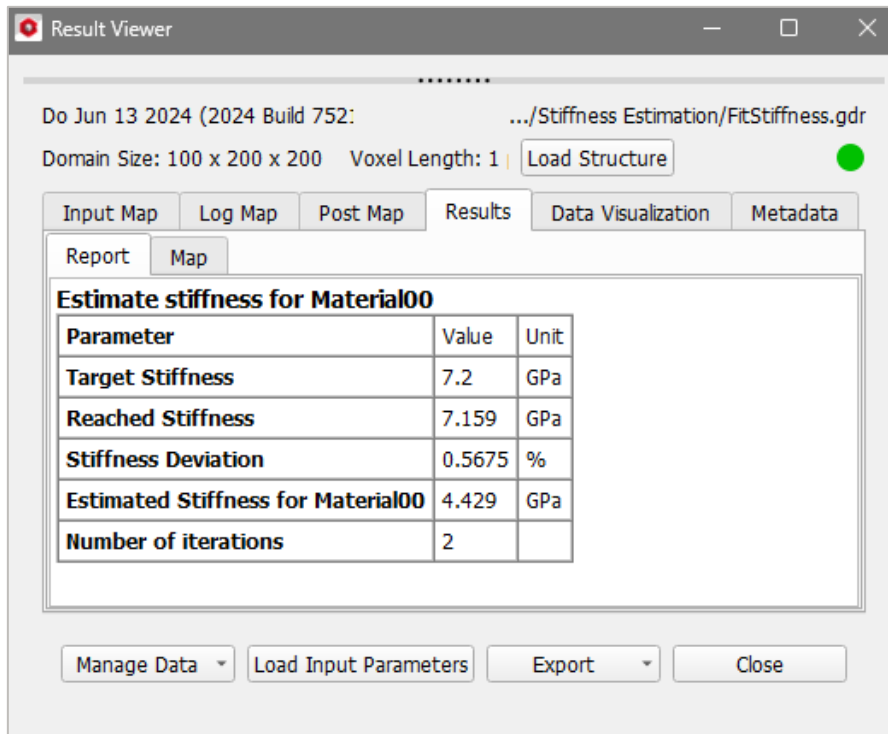

In this example, the stiffness of the epoxy matrix (material ID00) of a composite structure is estimated. The table displayed in the **Results - Report** subtab shows that the estimated overall structure stiffness (**Reached Stiffness**) is 7.159 GPa and **Estimated Stiffness for Material00**, which is the stiffness for the epoxy matrix, is 4.429 GPa. The fitting process in this example took 3 iterations.

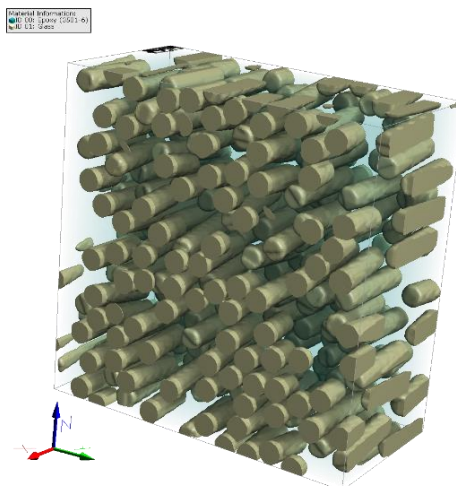

APPENDIX I: EXAMPLES AND VISUALIZATION

This section contains examples for **ElastoDict**-Effective Stiffness and for **ElastoDict**-Deformations. For some of the examples, suggestions for visualizations are made.

ELASTODICT-EFFECTIVE STIFFNESS

The general visualization options for **ElastoDict**-Effective Stiffness are presented here. These options apply for arbitrary **ElastoDict**-Effective Stiffness runs. The simulation settings are not relevant here.

VISUALIZING THE STRUCTURE

The structure used in this example is shown here and the settings for the visualization of this image are shown below.

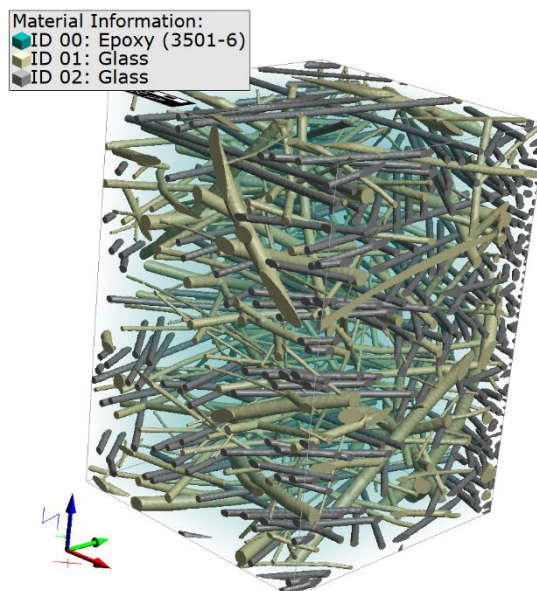

Render the structure in 3D (by clicking 3D) and go to the **Structure** tab in the visualization panel (above the Visualization area). Set the **Structure Renderer** to **Smooth**. Then, select **Transp. Mode** to **Volume**, set the **Transparent Material ID** to 00, and set the **Transparency** value to 0.10.

Usually, the material with ID 00 is set to invisible, so the transparency setting has no effect.

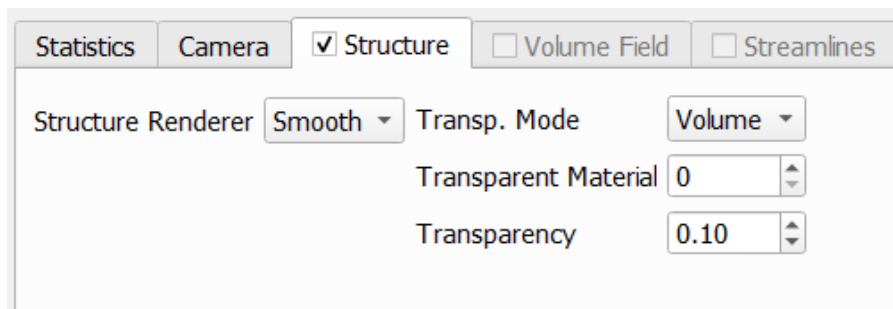

Click  to open the **Color & Visibility Settings** dialog and check **visible** to enable visibility for the material ID 00.

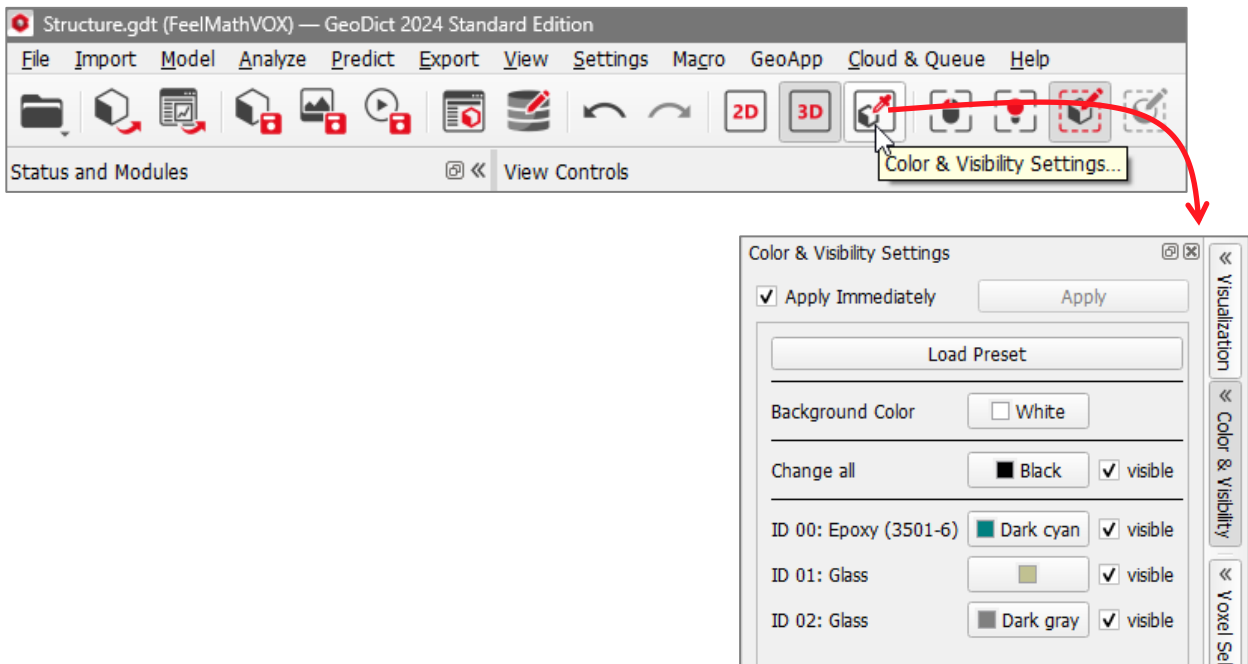

VISUALIZATION OF DISPLACEMENT AND STRESSES

After all selected load cases have been computed, result fields can be loaded by choosing the corresponding *.das file and clicking **Load Results** in the Result Viewer (*.gdr).

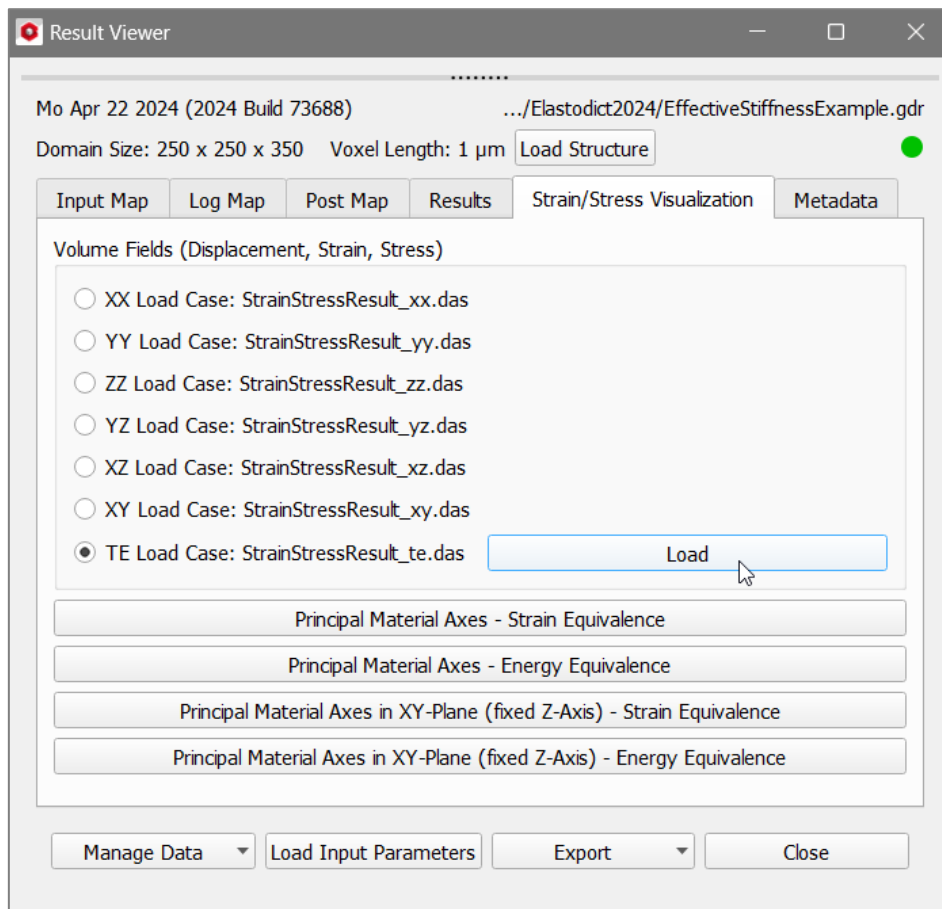

In the next dialog, choose the components which should be visualized: Strain and Stress for all calculated load cases, like e.g., von Mises Strain and Stress,

DisplacementX, DisplacementY, DisplacementZ, and Displacement. Check the load cases of interest and click **OK**.

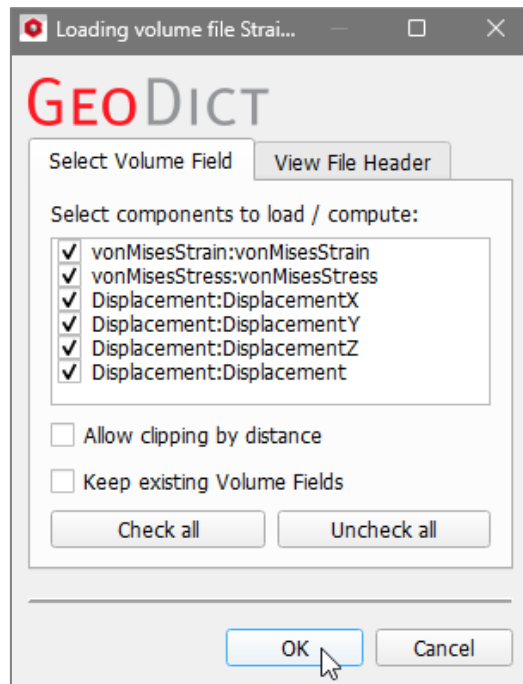

Choose the displayed data through the **Color by** pull-down menu, under the **Volume Field** tab, in the Visualization panel above the Visualization Area.

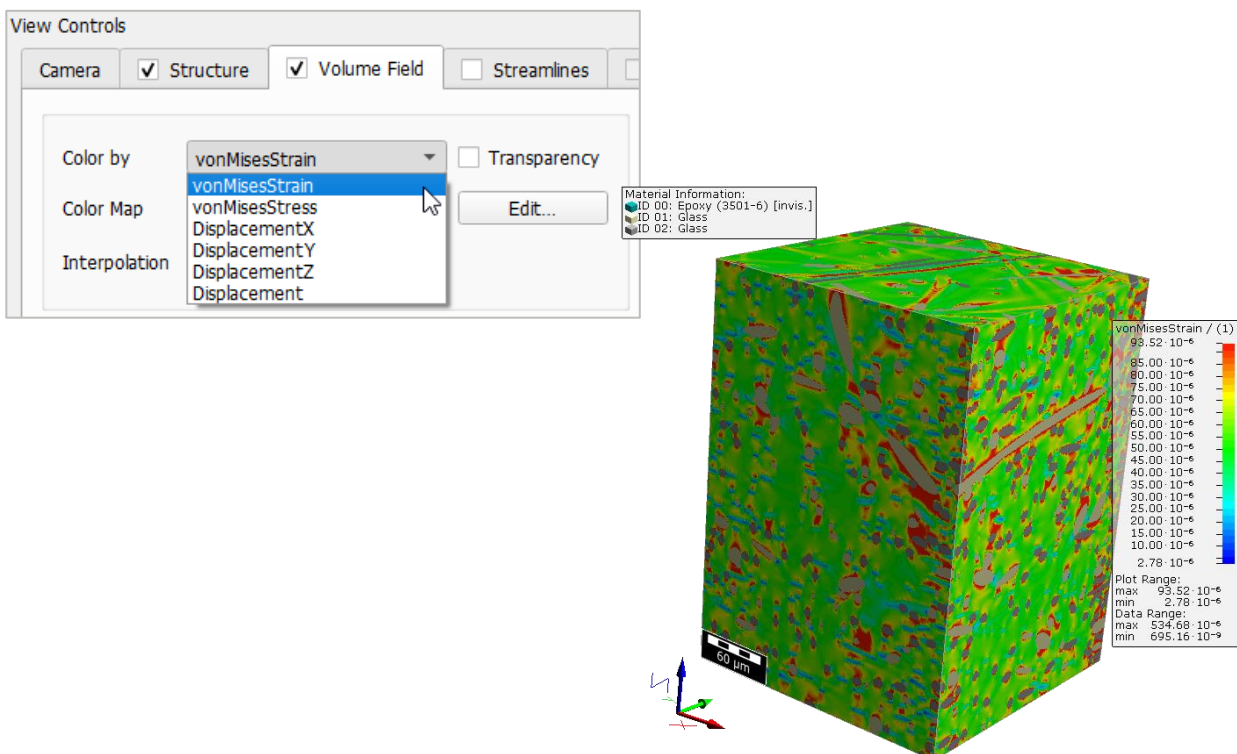

Tools are available for the visualization in 2D Cross Section (SEM) and in 3D Rendering.

For 2D visualization, select **View** → **2D Cross Section (SEM)** in the Menu bar. The control of 2D visualization parameters is also done through the Visualization panel above the Visualization Area.

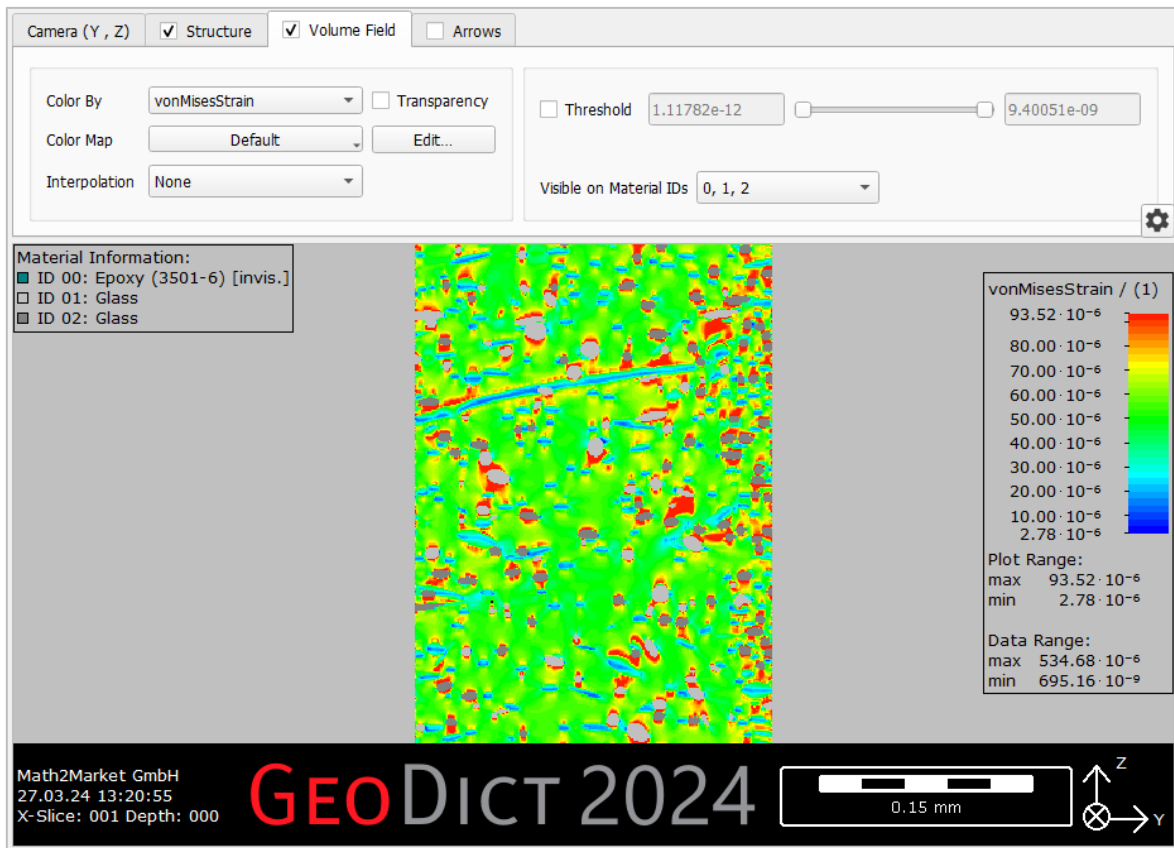

The structure in the model can be set to invisible to observe only the results (Volume Field). For this, select **View** and un-check **Structure** in the menu bar or directly in the **View Controls** tab.

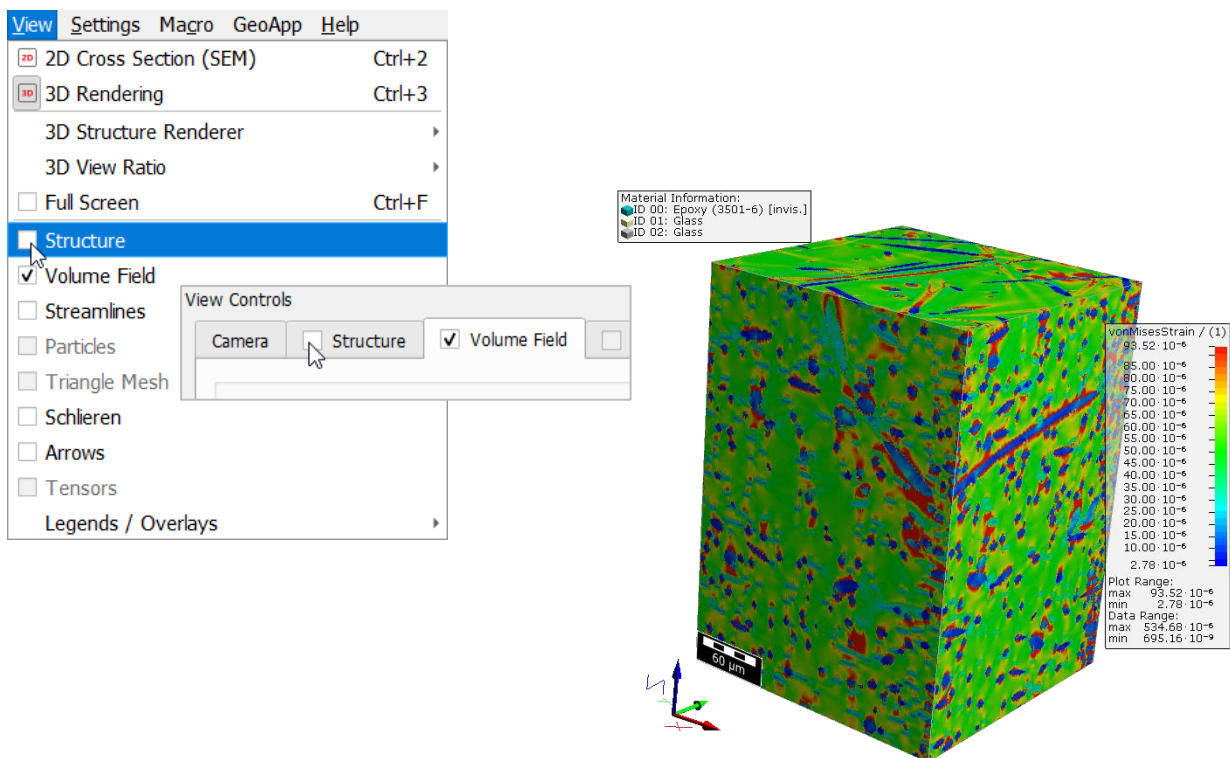

In 2D and 3D Rendering, a color bar appears to the right (if the default position is not changed) during the visualization of the result file, indicating the gradation of the currently selected property.

Click the **Edit...** button to edit the Default Color Map or add a new Colormap by choosing **Add...** in the dropdown menu (and then click the **Edit...** button). Alternatively, new colormaps can also be defined in the **Color Map** dialog.

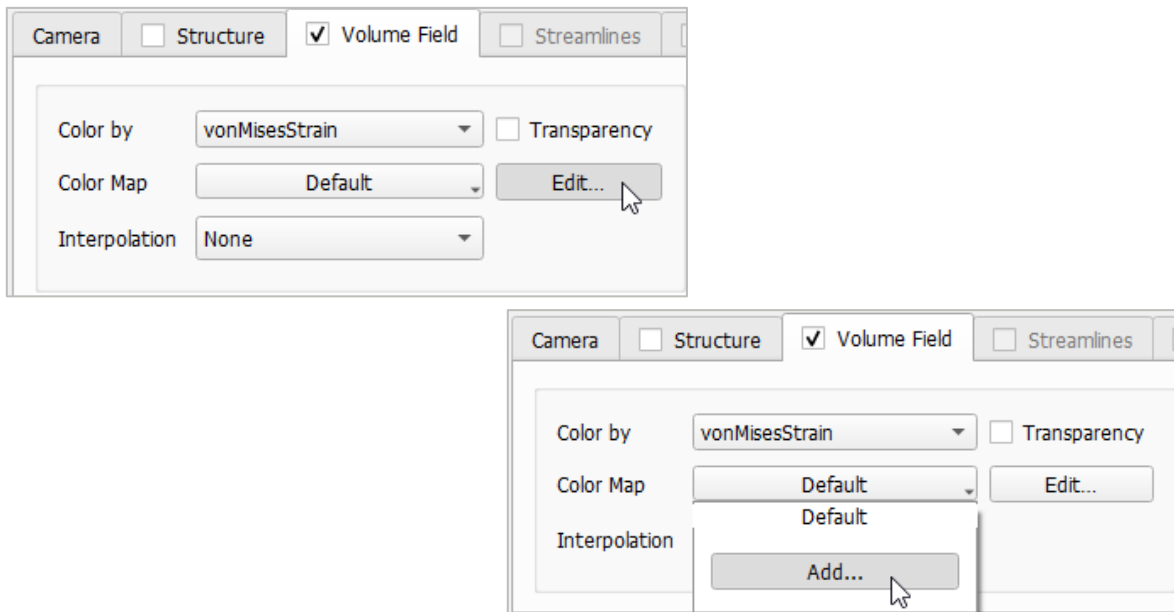

In the **Color Map** dialog, define the upper and lower limits of the color scale, add transparency to the visualized result field, and assign a particular **Color Space** (RGB, HSV, LAB).

The values entered in the **Color Map** dialog can be saved into a *.gps (GeoDict Project Settings) file by clicking on the first icon in the lower left corner. By clicking on the second icon settings can be loaded again from a *.gps file.

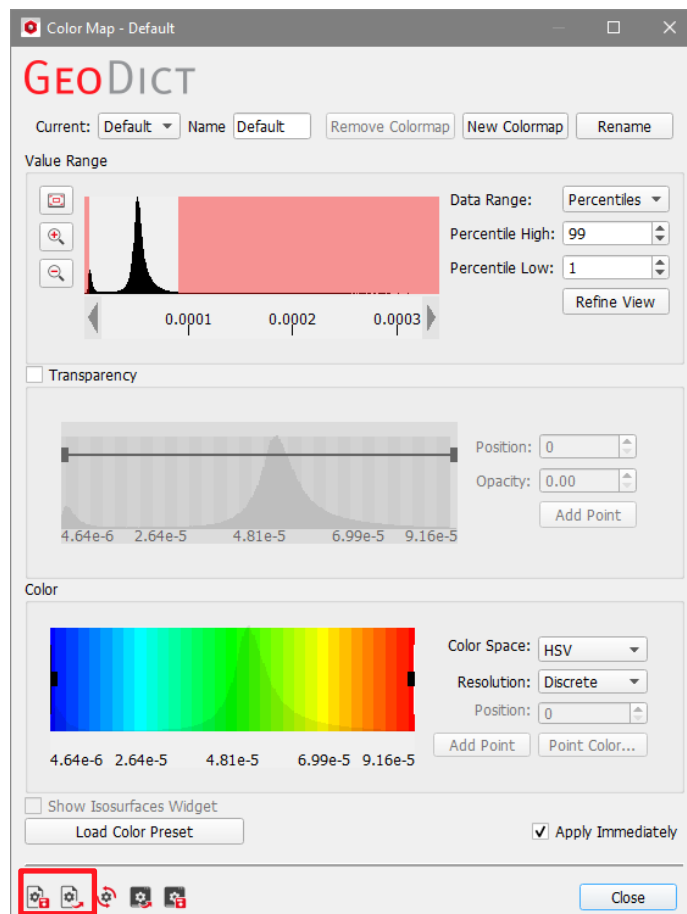

As you can observe in the histogram in the **Value Range** panel, the values concentrate in an area below a value 5.0×10^{-5} . To highlight the areas with high strain, we increase the **Percentile Low** to 80.

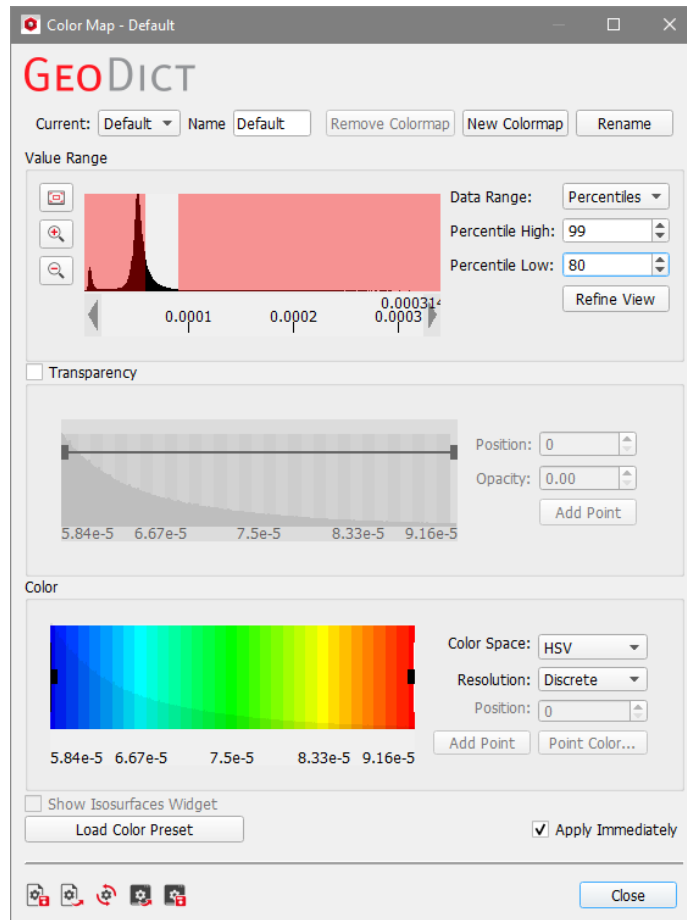

Note how the color of the result field in the Visualization area and the histogram change accordingly.

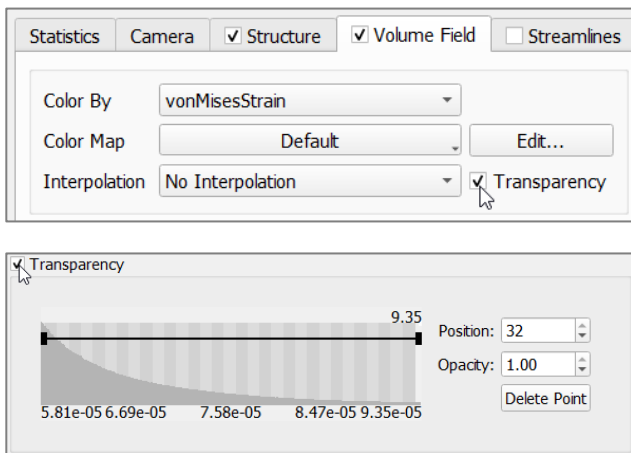

Material Information:
 ID 00: Epoxy (3501-6) [invis.]
 ID 01: Glass
 ID 02: Glass

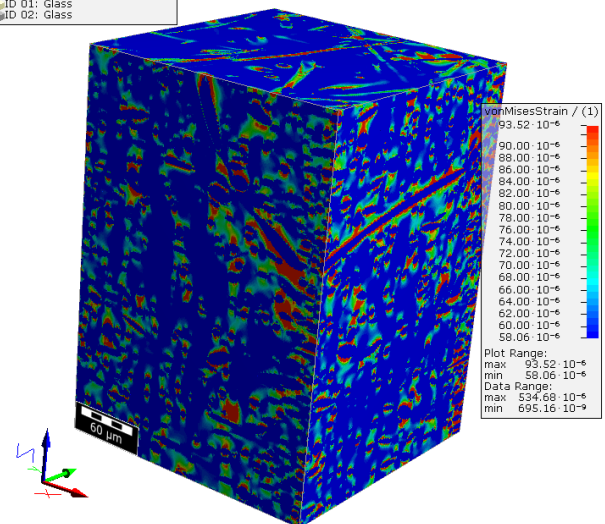

To emphasize the areas where the strain is elevated, you can activate **Transparency** under the Volume Field tab or directly in the **Color Map** dialog. Make sure that **No Interpolation** is selected in the **Interpolation** dropdown menu and then modify the transparency curve in the Color Map dialog, as indicated in the image on the right.

In the figure below, the transparency for low values is increased to see through these areas, and upper values with a high transparency are highlighted.

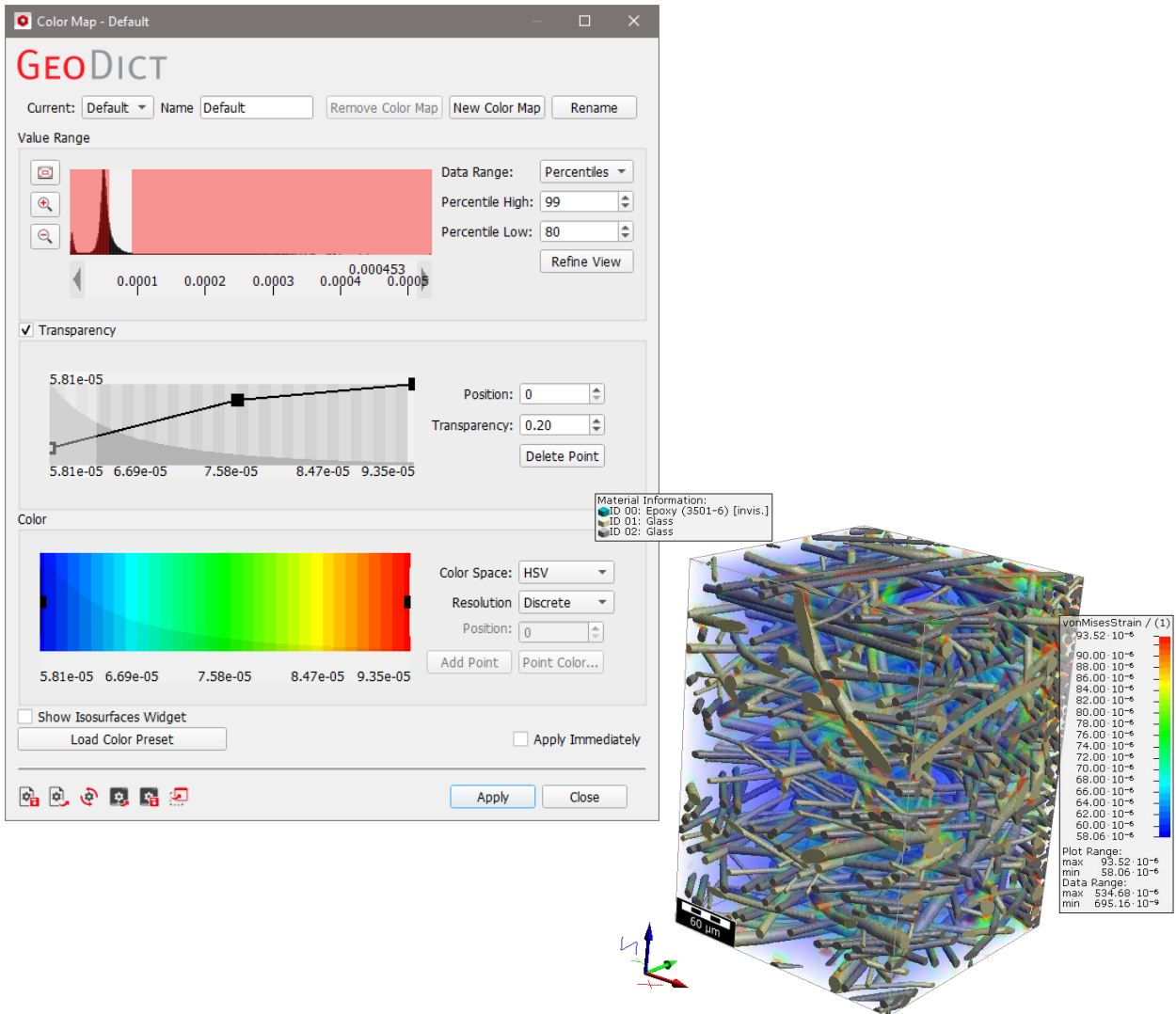

CLIPPING STRUCTURE AND RESULTS

The displayed results can also be clipped spatially in all three directions (**ClipX**, **ClipY**, **ClipZ**) with the sliders or by direct input. This enables the simultaneous visualization of the structure and the corresponding results.

Make sure that the structure is set to visible (**View** → checked **Structure**).

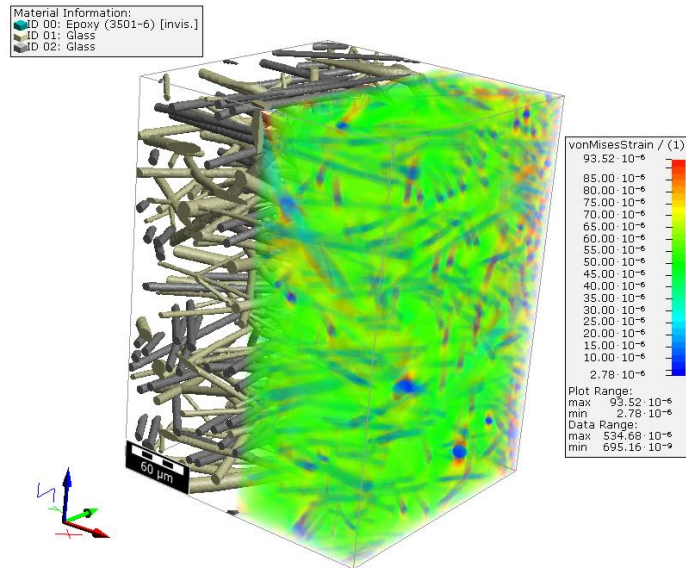
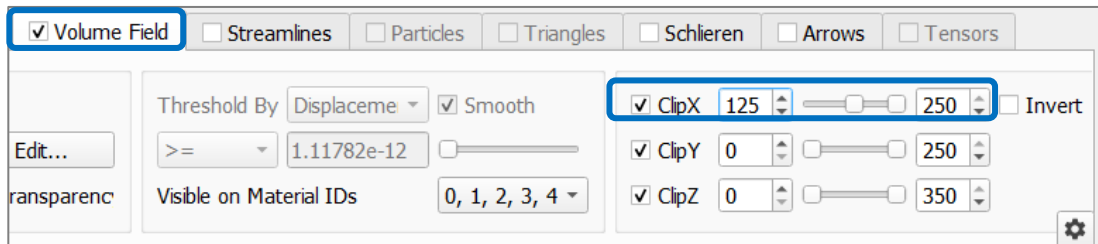
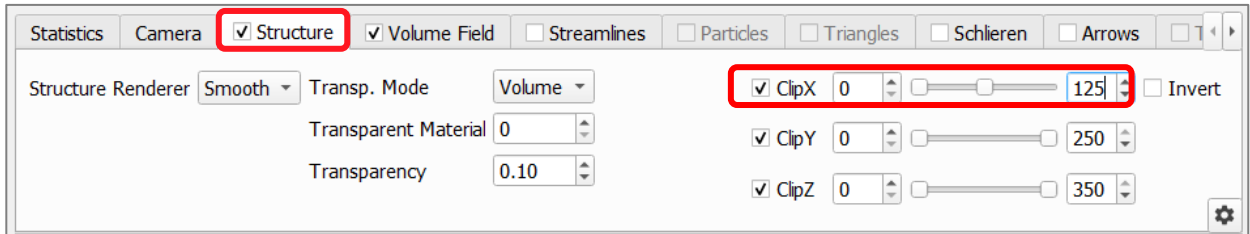

VISUALIZATION OF PRINCIPAL MATERIAL AXES

When all load cases (XX, YY, ZZ, XY, XZ, YZ) have been computed, the principal material axis can be visualized by clicking **Principal Material Axes – Strain Equivalence** or **Principal Material Axes – Energy Equivalence** under the Strain/Stress Visualization tab of the Result Viewer.

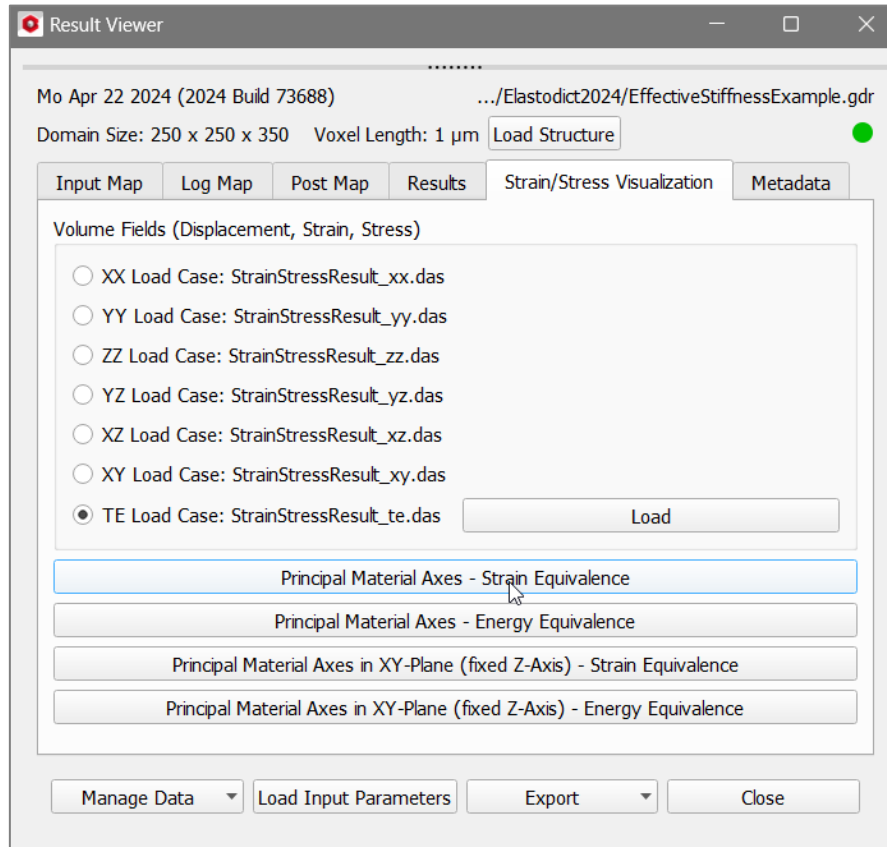

The axes are best to observe when the structure is transparent. For this, switch off the visualization of the results (**View** → uncheck **Volume Fields**), choose the Structure Renderer to **Box** and set the **Transp. Mode** to **Volume** (both options under the **Structure** tab in the Visualization panel).

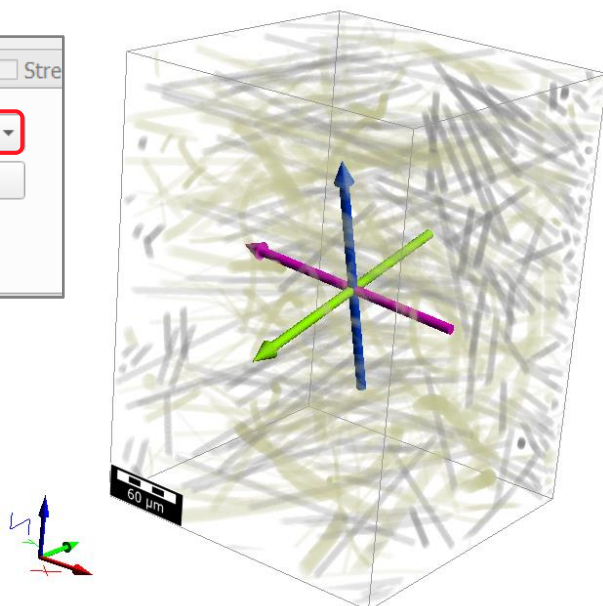
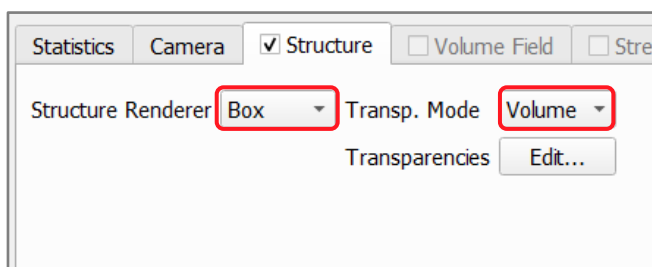

ELASTODICT - DEFORMATIONS

This section contains an example of how to simulate and visualize matrix damage with **ElastoDict** - Deformations.

MATRIX DAMAGE

ElastoDict-Deformations can be used to determine matrix damage in a composite model. In this example, E-Glass fibers are combined with an epoxy matrix. The structure used for this example is generated with **FiberGeo**.

Select **Deformations** from the pull-down menu in the **ElastoDict** module section.

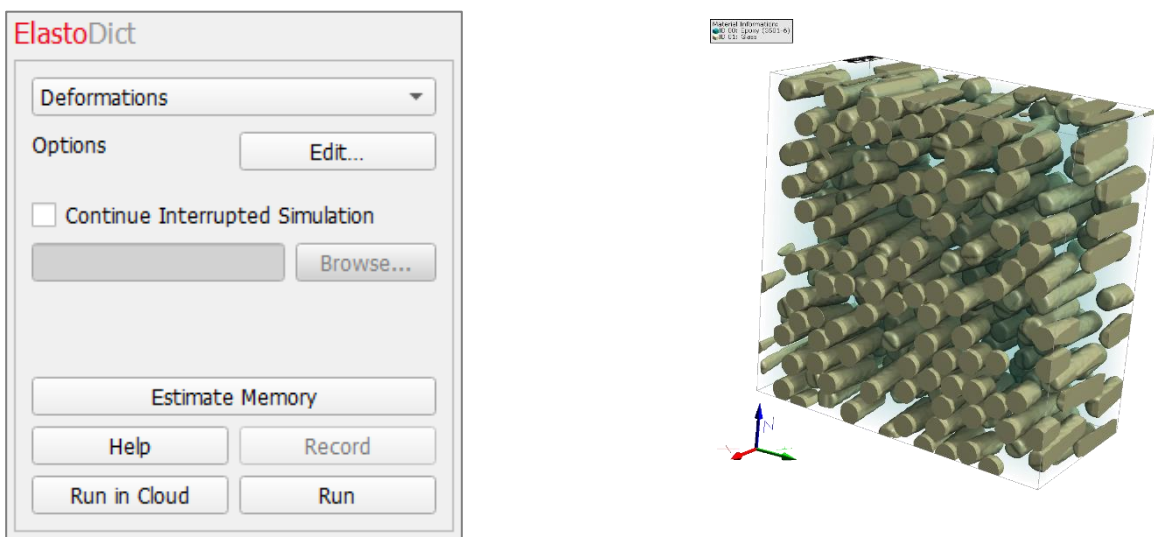

In the **Large Deformation Options** dialog, under the **Constituent Materials** tab, set the materials to *Epoxy (3501-6)* with the *Damage (UMAT)* material model and *Glass* with the *E-Glass (Isotropic)* material model. The **Failure Stress** option for *Glass* can additionally be enabled, although it is not necessary for this example.

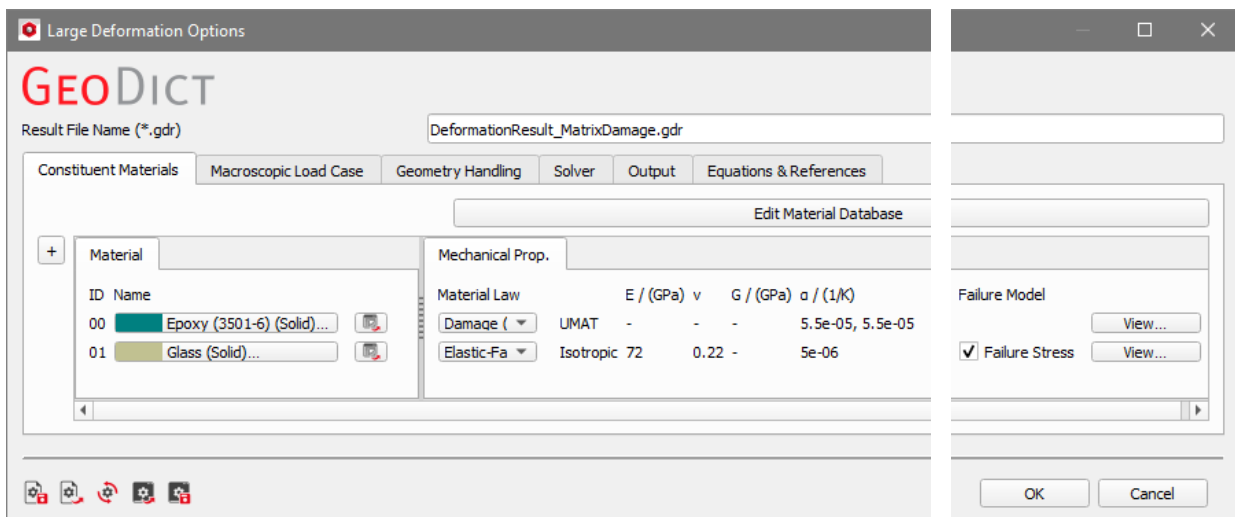

Under the **Macroscopic Load Case** tab, the experiment is set to **Uniaxial Experiment - Tensile**. A maximal strain of 0.6 % is applied in 30 steps (choose **Predefined Shape**, set **Magnitude** to 0.6 %, **Length** to 0.6 s and the **Number of Steps** to 30. Click apply to set the load in the **Load Table**). For damage simulations, it is useful to choose small steps (here, 0.02 %).

Under the **Geometry Handling** tab, keep the default settings.

Under the **Solver** tab, set the method to **Fast (Conjugate Gradient)**. Keep the **Tolerance** at the default of 0.0001 since a high accuracy is important, especially for simulations with damage.

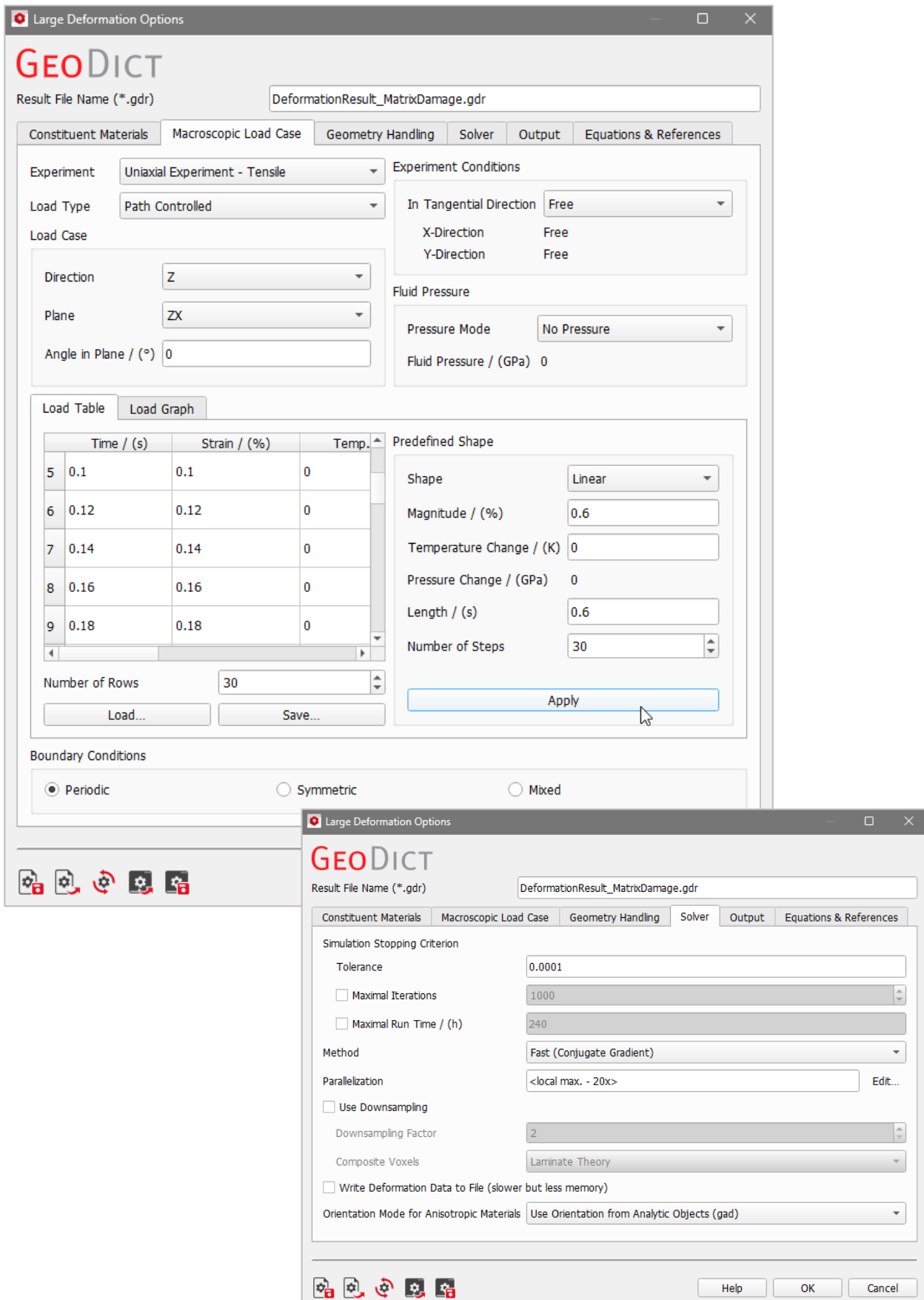

Under the **Output** tab, uncheck **Write Deformed Geometry** since generating the deformed geometries takes additional computation time and the deformed geometries are not relevant in most damage simulations (since the strain at the point of failure is often very low).

Analogously, writing volume fields might take a significant amount of disk space and time, depending on the size of the structure. Some disk-space and computational time is saved by unchecking stress, strain, and displacement fields which do not need to be visualized. Therefore, keep only the volume fields **Stress - Von Mises** and **Strain - Von Mises** and the **Material State Variables** (containing the damage and failure variables in this example).

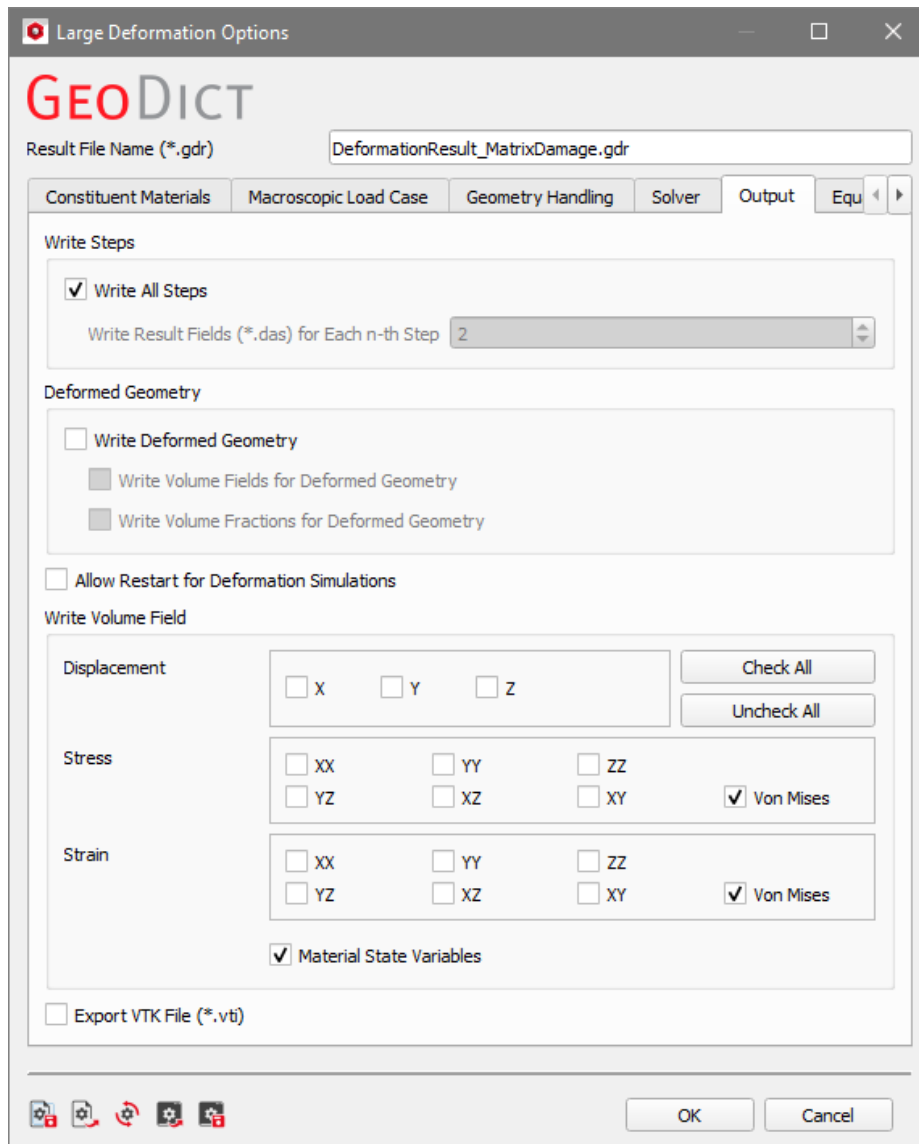

Click **OK** to close the **Options** dialog and start the simulation by clicking **Run** in the **GeoDict** GUI main screen.

After the simulation is finished, the result file is opened automatically in the Result Viewer at the **Results - Report** subtab.

Under the **Results - Plots** subtab, the results of the deformation during the time series experiment are plotted as **Stress-Strain** chart (X-Axis: Strain Z-Dir; Y-Axis: Stress Z-Dir). Increasing damage leads to decreasing stiffness in the structure.

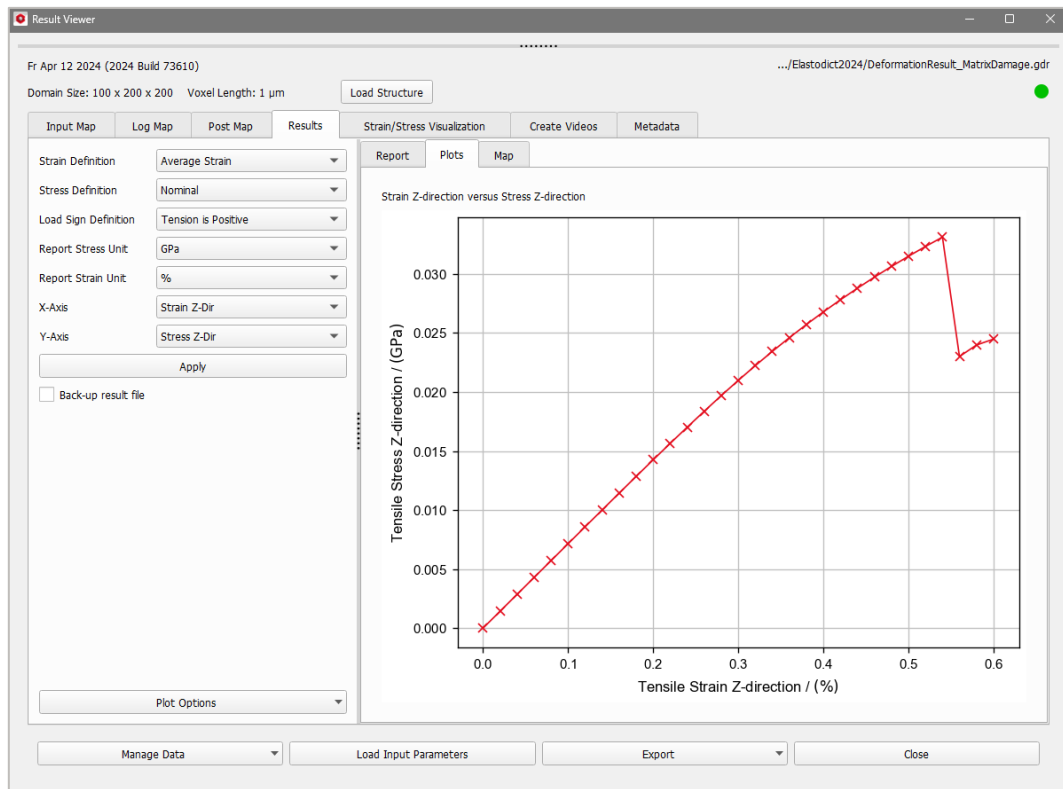

Choose **Material00_Damage** for the Y-Axis and click **Apply...** to plot the average matrix damage in the the matrix material (0 is no damage, 1 is maximal damage).

As it can be observed in the plot, the average damage increases constantly until the point of failure (which can be recognized on the drop in the stress-strain curve at a strain of 0.56 % in the plot above), but it reaches a plateau (with a much smaller increase) after failure. Failure in a composite is a local phenomenon: As soon as a crack occurs (with a high local damage), the rest of the structure is unloaded.

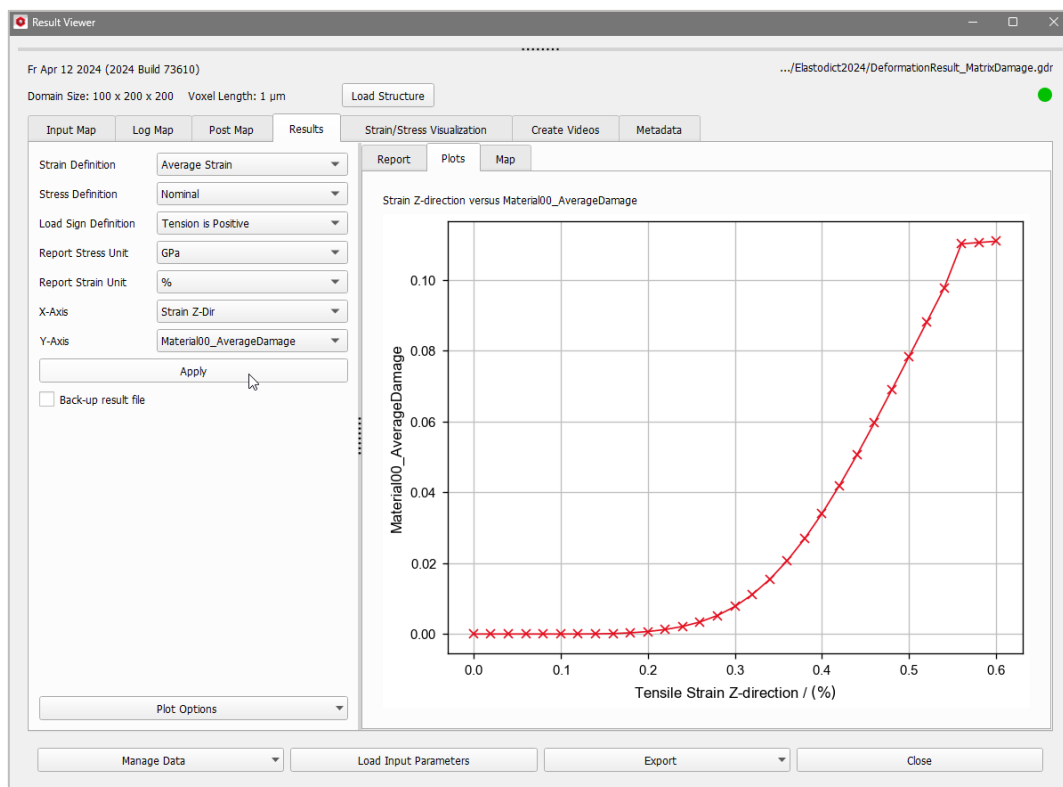

Other graphs of interest can be plotted by changing the selections of the **X-Axis** and the **Y-Axis** pull-down menus.

The original structure can be loaded with the **Load Structure** button.

The **Strain/Stress Visualization** tab contains the volume fields of the **Time Steps**, which can be selected from the pull-down menu (here, the point of failure at 0.56 s is selected) and loaded by clicking **Load**.

The components whose results can be visualized are checked in the list e.g., here von Mises Strain, von Mises Stress, Damage (Damage_0) and failure (failure_1). The numbers (0 in Damage_0 and 1 in failure_1) stand for the Material IDs to which the volume fields belong.

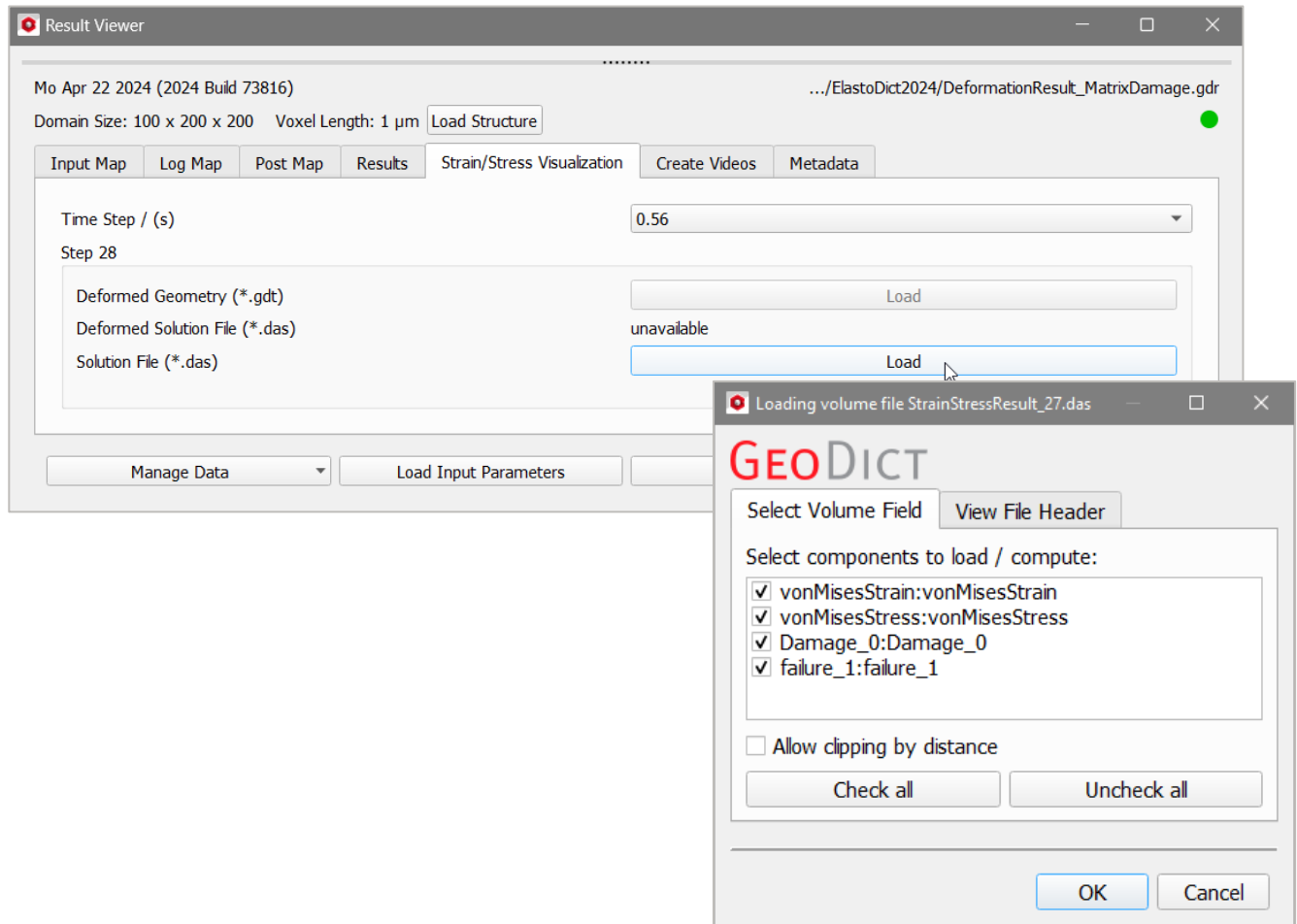

Click **OK**, to load the components.

In 2D and 3D Rendering, a color bar appears to the right (default position) during the visualization of the result file, indicating the gradation of the selected component.

Further visualization parameters can be set under the **Volume Field** tab, in the Visualization panel above the Visualization Area. For more information, see the [Visualization](#) handbook.

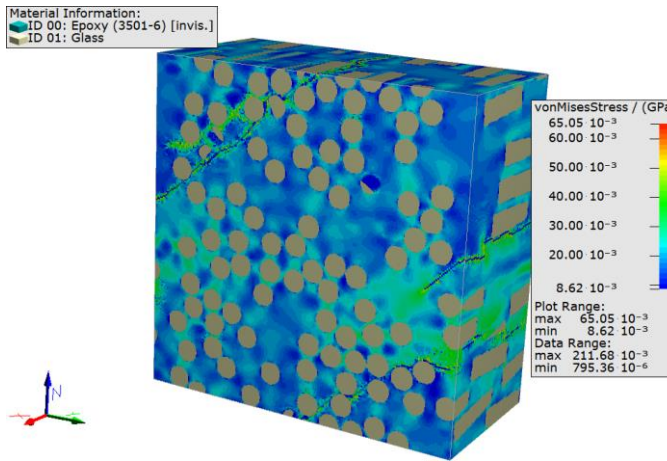

The structure is loaded in Z-direction, therefore the highest stresses in the material occur in the areas between fibers which lie closely together. Cracks in the matrix can be detected where the stresses are close to zero.

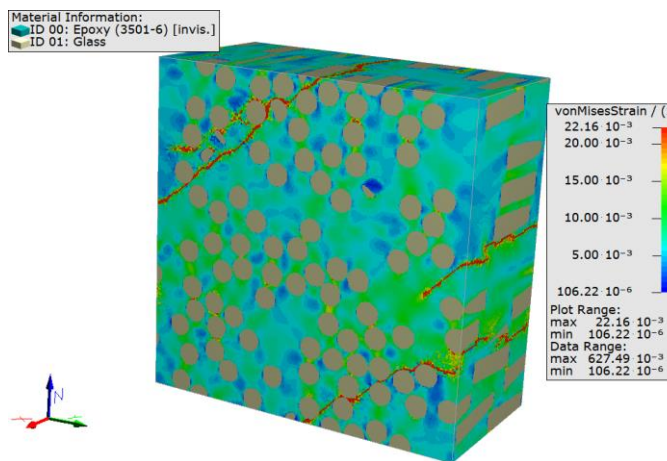

The highest strain can be observed at cracks. There, the stiffness of the matrix material is lowered due to the damage, which leads to high strain values and low stress values.

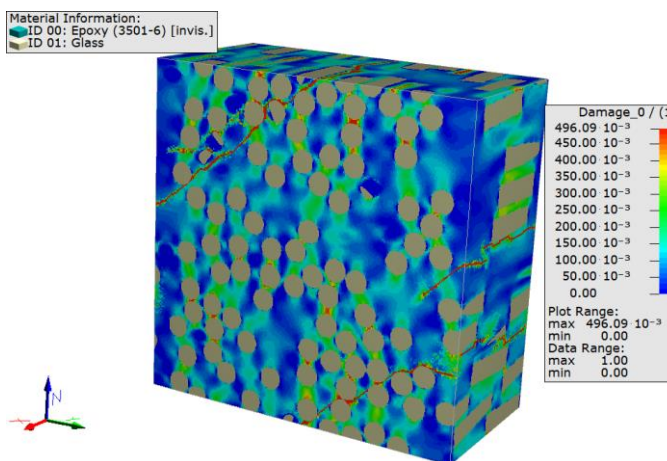

When damage is visualized, it is recommended to set the **Data Range** in the **Color Map** dialog to **Min/Max** or manually to a minimal value of 0.0 and a maximal value of 1.0 (see also screenshot on the next page). Then, the fully damaged areas are clearly visible.

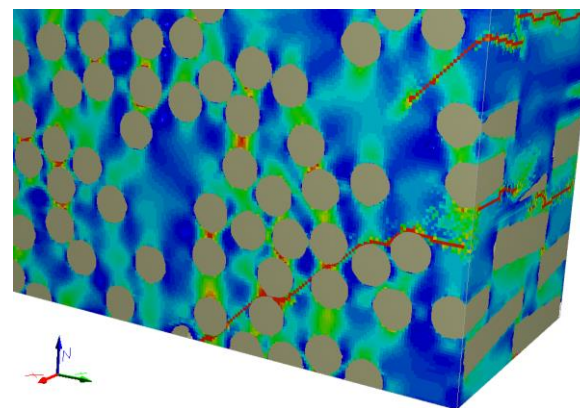

The crack in the material can be best visualized with the **Transparency** option for the volume field. For this, set the transparency as shown in the screenshot below: Choose low values (e.g. 0.2) for low damage values (in this example, for damage values lower than 0.75), and high values (1, which means no transparency) for high damage values (here, for damage values above 0.875).

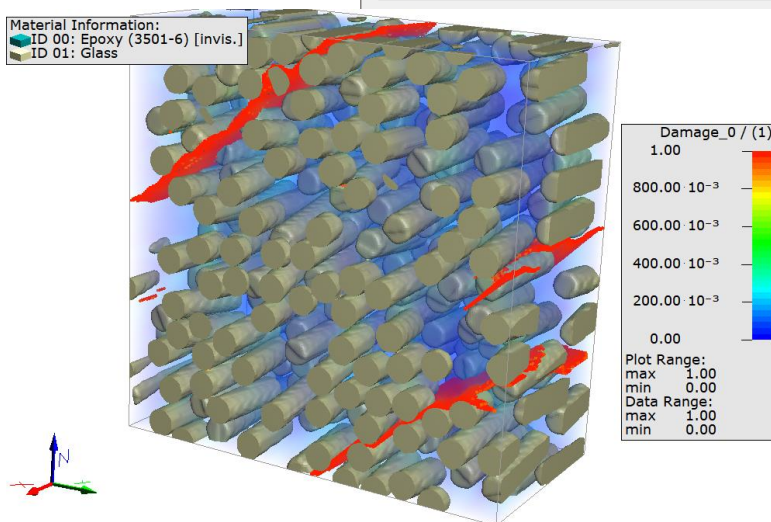
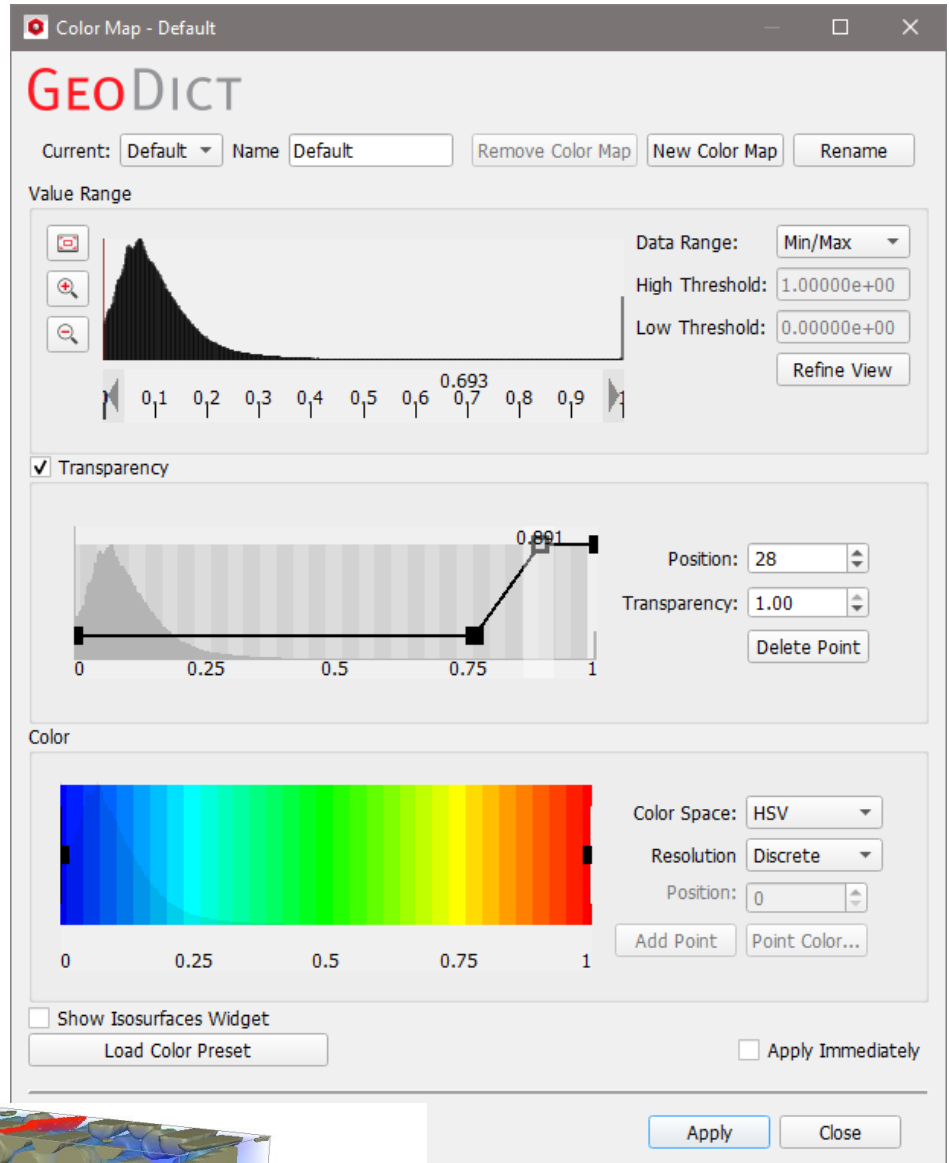

APPENDIX II: NONLINEAR MATERIAL MODELS IN ELASTODICT

In **ElastoDict**, several types of nonlinear material laws are integrated. The next section explains how these material laws can be set up. Additionally, it is also possible to program user-defined material laws through the UMAT interface (see page [114](#))

INTERNAL NONLINEAR MATERIAL LAWS IN FEELMATH

Several nonlinear material laws are delivered with **GeoDict** and may be conveniently set up in the **GeoDict** Material Database dialog. See the [Material Database](#) handbook for more information.

The available material laws are: **Plasticity**, **Damage**, **Viscosity** and **Failure**. All these material models are only available **Without Geometric Nonlinearity**.

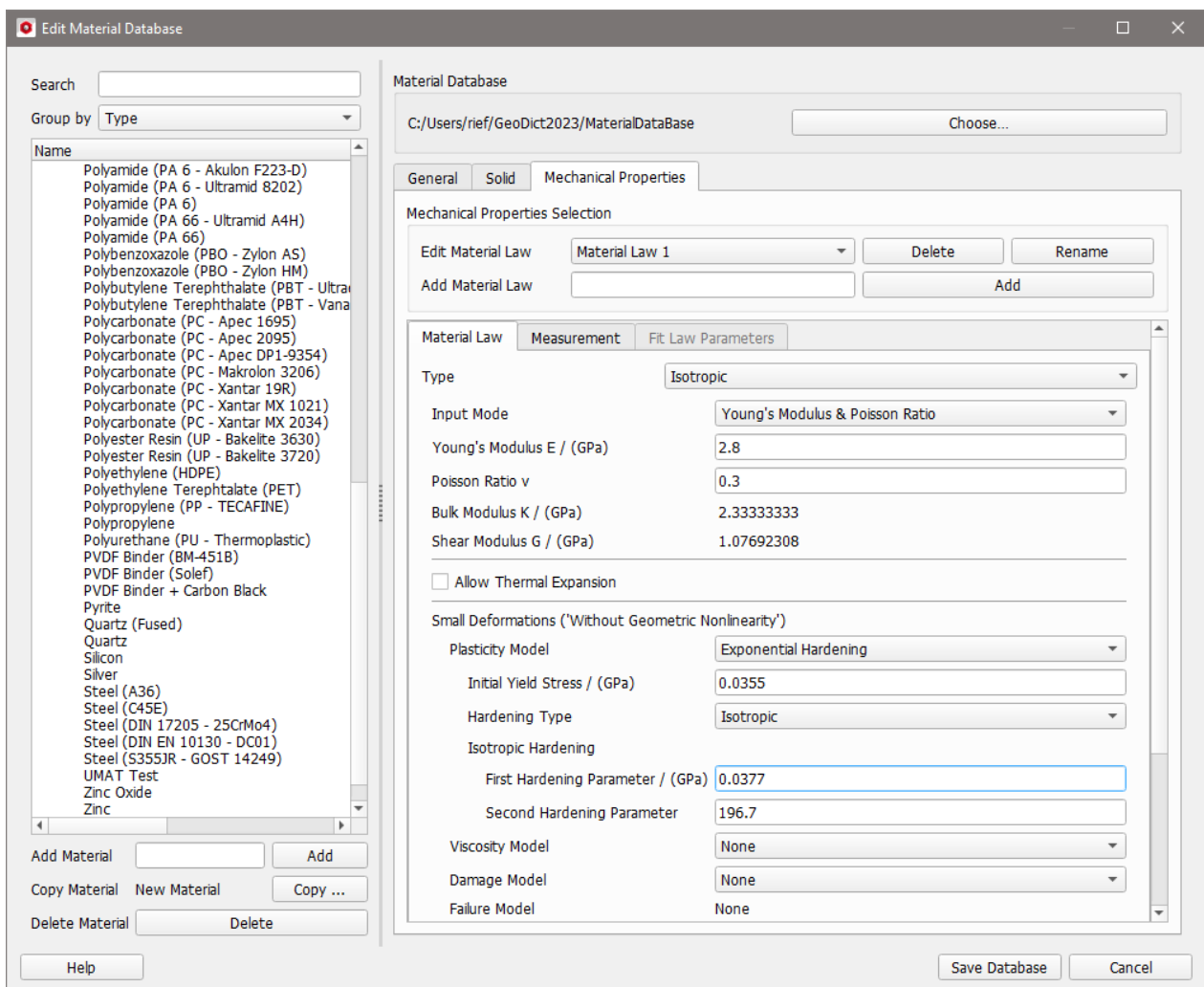

These material laws can be combined in different ways:

- Plasticity, damage, and viscosity can be combined. For these combinations, only the exponential damage model is available.
- The Mazars damage model cannot be combined with any other model.
- The Failure model cannot be combined with any other model.

LINEAR ELASTICITY

The constants for linear elastic materials need to be defined for each material law in **ElastoDict**. All nonlinear material laws that can be selected in **GeoDict**'s material Database are based on linear isotropic elastic materials, except of the failure model, which is also available for transverse isotropic materials.

Material Law	Measurement	Fit Law Parameters
Type	Isotropic	
Input Mode	Young's Modulus & Poisson Ratio	
Young's Modulus E / (GPa)	2.8	
Poisson Ratio ν	0.3	
Bulk Modulus K / (GPa)	2.33333333	
Shear Modulus G / (GPa)	1.07692308	

PLASTICITY

Plasticity in materials describes the effect that a deformation remains when the load is removed. In **GeoDict**, three different plastic material laws are available: **Perfect Plasticity**, **Bilinear Hardening** (Affine linear Hardening) and **Exponential Hardening**.

For understanding plastic material laws, the two most important parameters are the elastic strain ε_{elas} and the plastic strain ε_{plas} which add up to the strain ε . The elastic strain is recoverable, whereas the plastic strain remains in the material after unloading. The relation of the elastic strain ε_{elas} to the stress σ is described by [Hooke's law](#), and the relation of the plastic strain ε_{plas} to the stress σ is described by the chosen plastic material law.

As long as the stress is lower than the yield stress Y of the material, the deformation is purely elastic. After this point, an increase in stress leads to a combination of elastic and plastic strains. The yield stress increases through the plastic deformation, which means that the material is elastic up to this point under a new load. Nevertheless, the course of the plastic material always depends on the initial yield stress.

The three available plastic material laws differ in the relation between the plastic strain and the stress:

- **Perfect Plasticity:** As soon as the initial yield stress Y is reached, the stress remains at that level. From this point, the elastic strain stays constant, and all additional strain is purely plastic.
- **Bilinear (Affine linear) Hardening:** The stress is a linear function of the plastic strain

$$\sigma(\varepsilon_{plas}) = Y + H \cdot \varepsilon_{plas}$$

where H is the **Plastic Strain Hardening Modulus**.

The plastic strain hardening modulus is not the slope of the stress-strain curve, since it only takes the plastic strain into account. The slope of the stress-strain curve (after the yield stress is reached) is the **Tangential Modulus** T . The **Plastic Strain Hardening Modulus** and the **Tangential Modulus** are related as

$$H = \frac{T}{1 - \frac{T}{E}}$$

with the young's modulus E . In the material definition in **GeoDict**, either the **Plastic Strain Hardening Modulus** or the **Tangential Modulus** can be set.

- **Exponential Hardening**: The stress is related to the plastic strain via an exponential function

$$\sigma(\varepsilon_{plas}) = Y + a \cdot (1 - e^{-b \cdot \varepsilon_{plas}})$$

with the **First Hardening Parameter** a and the **Second Hardening Parameter** b .

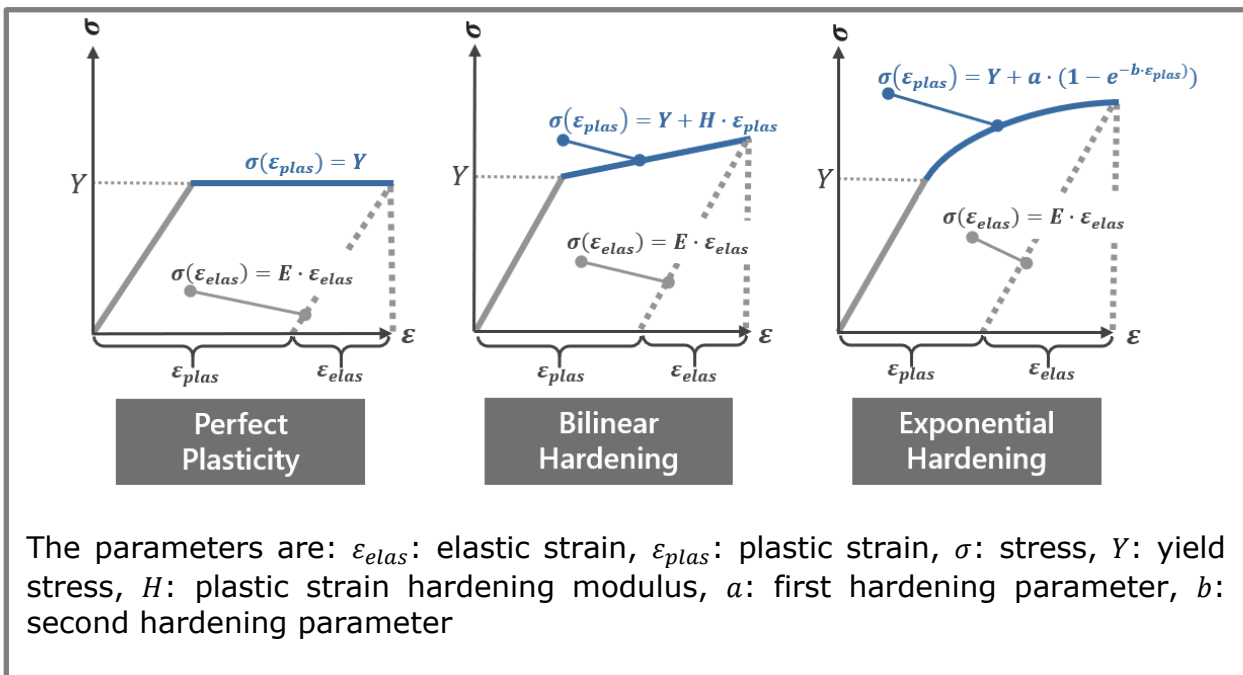

ISOTROPIC AND KINEMATIC HARDENING

Isotropic and **Kinematic Hardening** describe the effect of the plastic deformation on the yield surface (see [Wikipedia: Yield Surface](#) for further reference).

In summary, the yield surface grows isotropically with isotropic hardening, whereas it moves with kinematic hardening. In real materials, the material behavior is usually a combination of both hardening types.

How to set up the hardening type for a material is expert knowledge and can only be analyzed by measuring multiple load cycles for a material. Nevertheless, if only tension or compression is applied to a material, the results for both hardening types are the same, and it is sufficient to keep the default **Isotropic Hardening** when setting up a material law.

VISCOSITY

The material laws for plasticity can also be combined with viscosity to achieve viscoplastic material behavior. Three models are available: **linear Perzyna**, **nonlinear Perzyna** and **Michel-Suquet**.

The three models differ in their complexity. The linear Perzyna model is the least complex of the three. It has only one additional parameter (the reference strain rate) compared to time-independent plasticity. In general, one should first try if this model already fits the needs.

The other models should only be considered if the real material shows a behavior which is too complex for the linear Perzyna model. Both have the rate sensitivity parameter, which allows to define how a change in strain rate affects the material behavior. The Michel-Suquet model additionally has the drag stress parameter, which further influences the material behavior and allows to fine-tune the model.

In general, setting up a visco-plastic material law is more complex than setting up time-independent materials. Measuring a stress-strain curve is not enough to explain the behavior of a visco-plastic material. In contrast, more complex experiments are necessary, like e.g. creep tests, relaxation tests or DMA measurements (Dynamic mechanical analysis).

DAMAGE

With the damage models, the stiffness of the material is decreased with increasing material damage:

$$\sigma = (1 - D) \cdot E \cdot \varepsilon$$

with the damage variable D . The evolution of the damage D depends on the selected damage model, and the damage can only increase. The initial value is $D = 0$, and the maximal allowed value for the damage is $D = 0.99$. When unloaded, the material deforms elastically (with the decreased stiffness) back to its initial state.

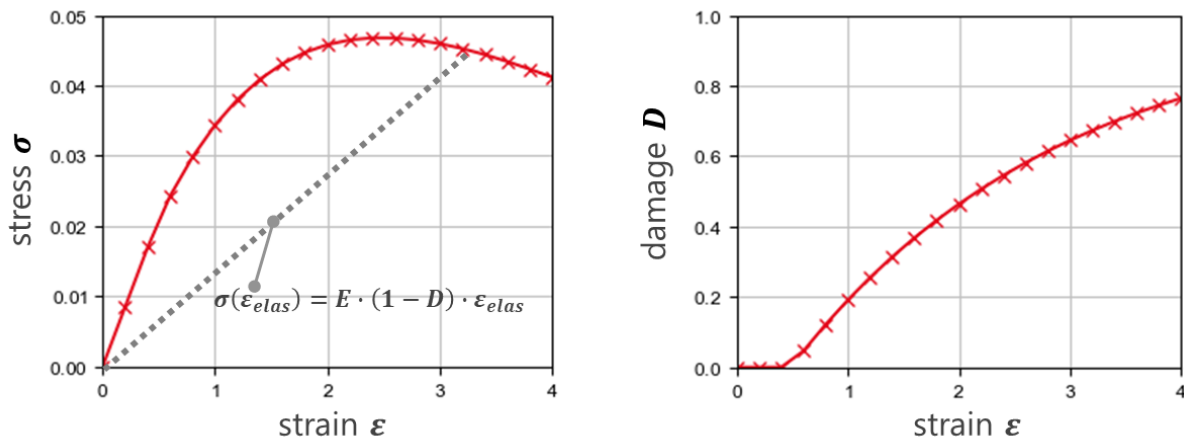

Two damage models are available in **GeoDict**: The **Exponential Damage** model and **Mazars' Damage** model (See reference on page [106](#)). Both models are very similar and differ only in the way they depend on the strain.

- **Mazars' Damage**: The damage depends on the strain, and the degradation begins as soon as the strain reaches the threshold d_0 :

$$D = 1 - \frac{d_0(1 - d_2)}{\varepsilon} - \frac{d_2}{e^{d_1(\varepsilon - d_0)}}, \varepsilon > d_0$$

with d_0 : minimal strain for damage, d_1 : damage hardening modulus, d_2 : damage evolution.

- **Exponential Damage**: The damage depends on the strain energy

$$U = U_{elas} + U_{plas} = \frac{E}{2} \cdot \varepsilon_{elas}^2 + \int_0^{\varepsilon_{plas}} (\sigma(\varepsilon_p) - Y) d\varepsilon_p$$

which is the sum of the elastic and plastic strain energies U_{elas} and U_{plas} . If no plastic deformations occur, the strain energy depends only on the elastic strains. The degradation begins as soon as the minimal energy for damage d_0 is reached:

$$D = 1 - \frac{d_0(1 - d_2)}{U} - \frac{d_2}{e^{d_1(U-d_0)}}, U > d_0$$

with d_0 : minimal energy for damage, d_1 : damage hardening modulus, d_2 : damage evolution.

The damage evolution formula is the same for both models, the significant difference is that the damage is driven by the strain for **Mazars' Damage** and driven by the elastic strain energy in the **Exponential Damage** model. In other words, the damage criterion for Mazars depends linearly on the strains, and a quadratic relation holds for the exponential damage model.

FAILURE

The **Failure** model in **GeoDict** is closely related to the damage models, but its approach is simpler. Instead of the continuous damage variable D , the failure model knows only two states: Failure or no failure. The material fails if the Failure Stress is exceeded, and the stiffness is degraded to 1 % of the original stiffness. The volume field for the failure parameter contains a 0 for voxels without failure, and a 1 for failed voxels. However, when calculating with downsampling, or when calculating on deformed geometries, there might be also failure values between 0 and 1 resulting from a combination of several voxels.

The **Failure** model is available for isotropic and for transverse isotropic materials. In the isotropic case, the reference stress is the von Mises stress, and in the transverse isotropic case, the stress in the respective directions is checked.

Check the guidelines on page [106](#) for a comparison of the damage and failure models in **GeoDict**.

GUIDELINES FOR PLASTICITY, DAMAGE AND FAILURE MODELS

The convergence for nonlinear materials can be bad if the simulation settings are not set up properly. Therefore, this section contains some best practices for these simulation types.

BOUNDARY CONDITIONS

Don't use **Force** boundary conditions, if possible:

With **Force** boundary conditions, it is possible to choose the applied load too high for the materials in the structure: For plastic materials and for the damage models, the maximal stress is limited by the material model. Therefore, applying a load which is higher than this maximal stress leads to unsolvable equations.

If it is important to use force boundary conditions (as e.g., in a cyclic load case, where the stresses should decrease to zero again), we recommend

- Do a first simulation with **Path** Boundary Conditions, to check out the maximal allowed stresses for the structure, *or*
- Check the materials carefully to estimate the maximum allowed load.

Nevertheless, even if the maximum allowed load is not reached, the convergence might be slow. For example, when using the exponential hardening model, a load slightly lower than the maximal allowed load might lead to strains near to infinity (which is also not realistic).

DAMAGE MODELS VS. FAILURE MODEL

The main difference between the damage models and the failure model is that the failure model decreases the stiffness suddenly, which introduces a discontinuity into the stress-strain relationship. The damage models lead to a gradual reduction of the stiffness. Thus, the damage models introduce no discontinuity, this means that the simulation is more stable and usually faster. Nevertheless, this gradual reduction of stiffness can be arbitrarily fast – this means that nearly the same results as with the failure model can be achieved. Additionally, the damage models can be combined with other models like e.g., plasticity.

The main advantage of the failure model is that it is easier to set up, since it contains less parameters. Additionally, the damage models are not available for the transverse isotropic case. Altogether, it is strongly recommended to use the damage models instead of the failure model, whenever possible.

NONLINEAR MATERIAL LAWS IN GEODICT - REFERENCES

J. Mazars: **Mechanical damage and fracture of concrete structures**. *Advances in fracture research*. (1981) **4**, pp. 1499 – 1506.

G. Alfano, F. De Angelis and L. Rosati: **General solution procedures in elasto/viscoplasticity**. *Computer Methods in Applied Mechanics and Engineering*, **190(39)** (2001), pp. 5123 – 5147.

J-C. Michel and P. Suquet: **A model-reduction approach in micromechanics of materials preserving the variational structure of constitutive relations**. *Journal of the Mechanics and Physics of Solids*, **90** (2016), pp. 254 – 285.

SETTING UP THE INTERNAL MATERIAL LAWS

To set up a material law in GeoDict, first open the material data base via **Settings – Edit Material Data Base ...** in the menu bar:

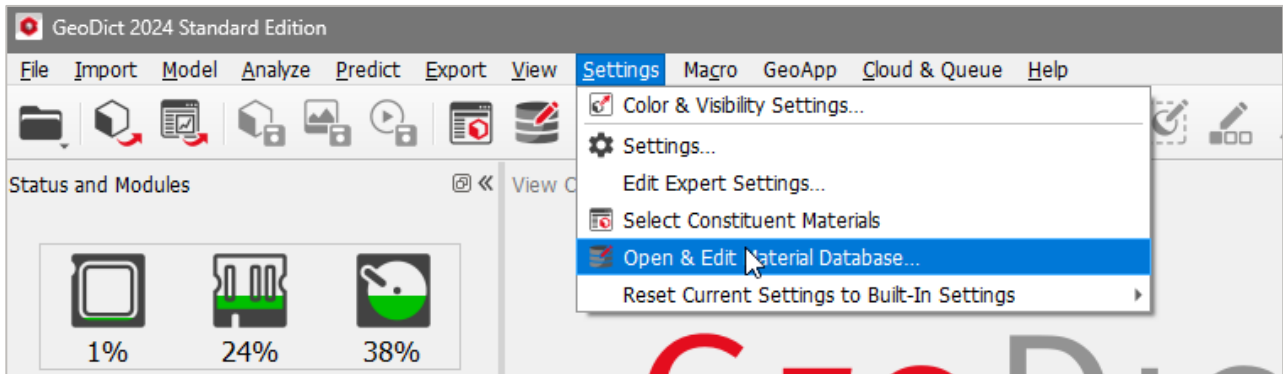

Then, either create a new material by entering a material name and clicking the **Add** button (as shown below), or open one of the materials in the database and add a material law to it.

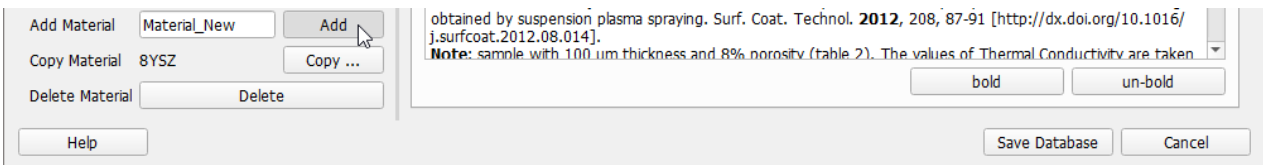

When creating a new material, make sure that the **Mechanical Properties** are activated under the **General** tab:

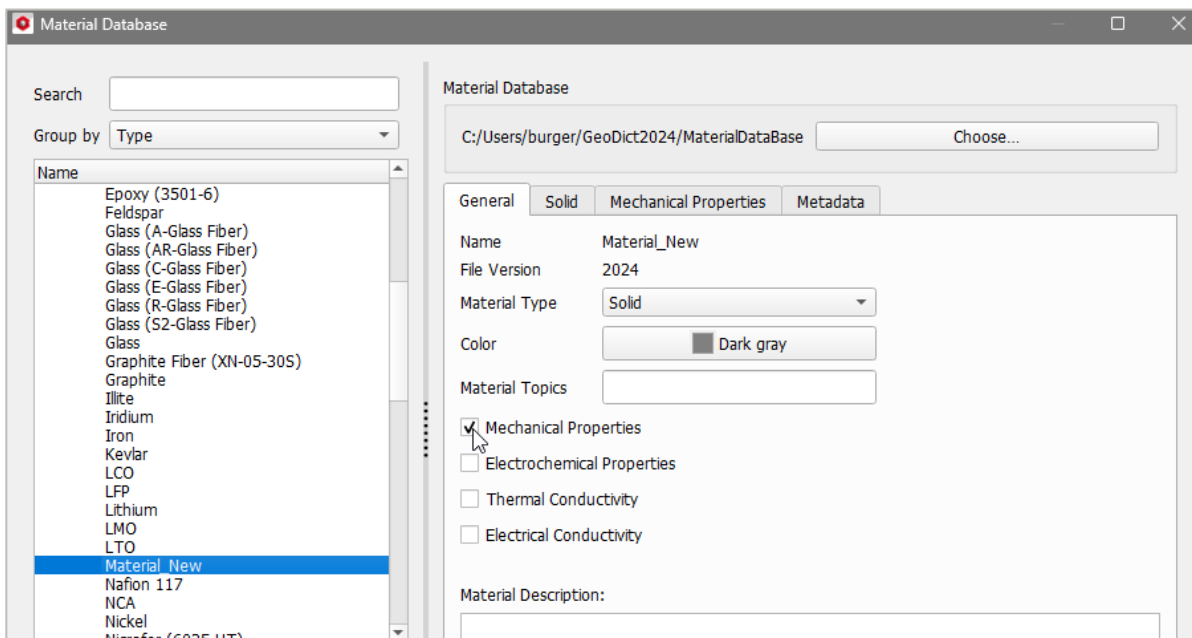

Switch to the **Mechanical Properties** tab. Here, existing material laws can be edited, or new material laws can be added. In the figure below, it is shown how to add a new material law: Enter the material law name in the field **Add Material Law** and click the **Add** button.

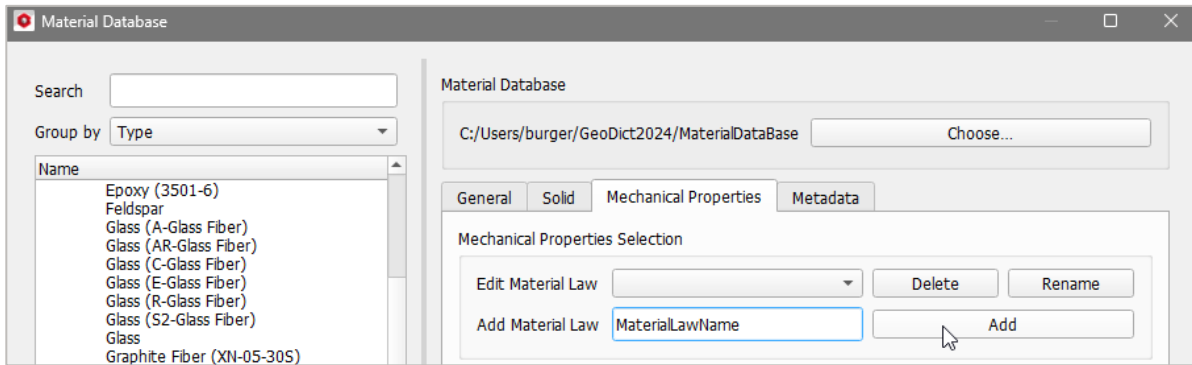

Then, the material parameters can be defined after selecting the material law. In the figure below, it is shown how to set up a material with Bilinear Hardening.

Other material laws can be defined by selecting the corresponding fields in the interface. After all material parameters are defined, make sure to save the database with the **Save Database** button in the lower right corner.

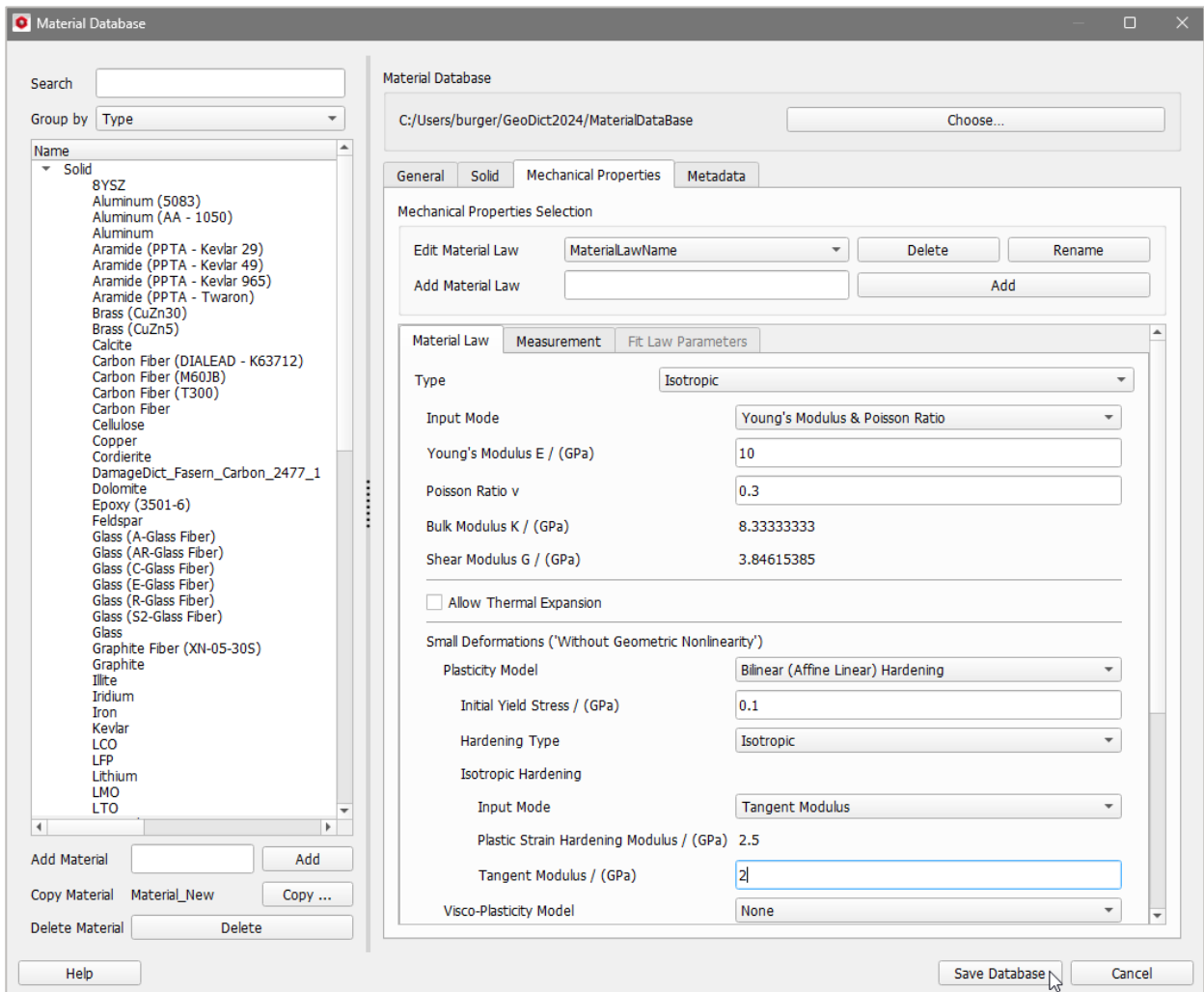

MATERIAL FITTING FOR THE INTERNAL MATERIAL LAWS

For nonlinear materials, finding the material parameters might be complicated. If measurement data for a given material is available, this data can be used to estimate the material parameters.

Material fitting is available for **Perfect Plasticity**, **Bilinear Hardening**, **Exponential Hardening** and both **Damage** models. For the material fitting, currently no combined material models are available.

Since GeoDict 2022, the material fitting routines are much faster than in previous versions. Now, the fitting relies on analytic formulas instead of repeated simulations – therefore the fitting finishes in several seconds instead of minutes as before.

MEASUREMENT

To fit a material law, a measurement must be loaded for the material. For this, check **Save a Measurement** under the **Measurement** tab of the current material law.

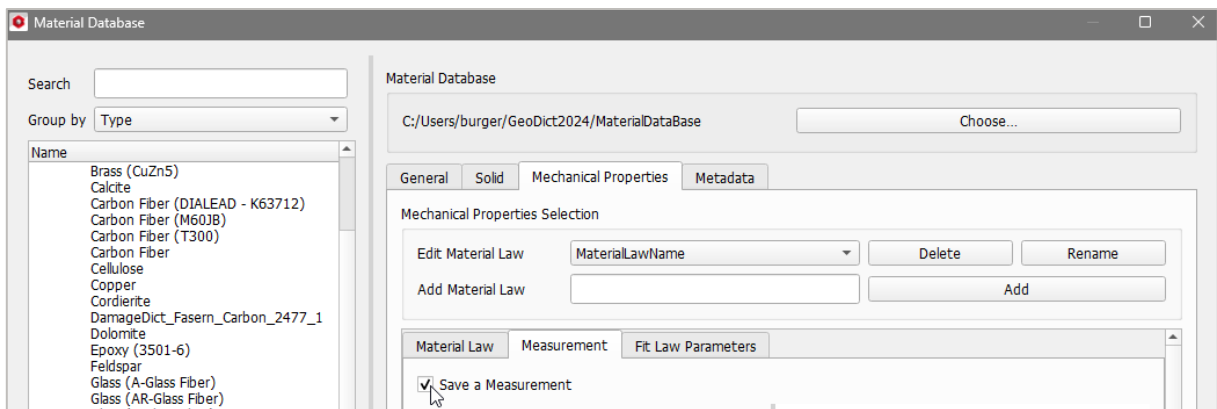

Material data can be loaded from a *.txt file with the **Load...** button.

The data must be formatted in two columns, the first column represents the strain values in percent, and the second row contains the corresponding stress values in GPa. Both columns must be separated by spaces.

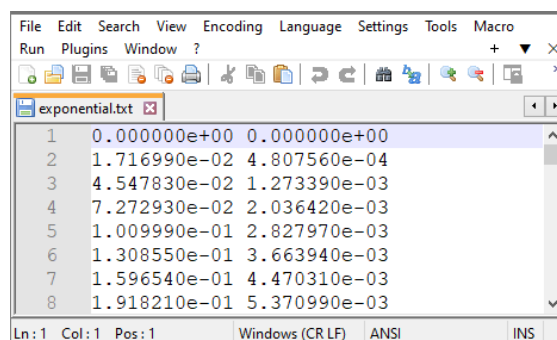
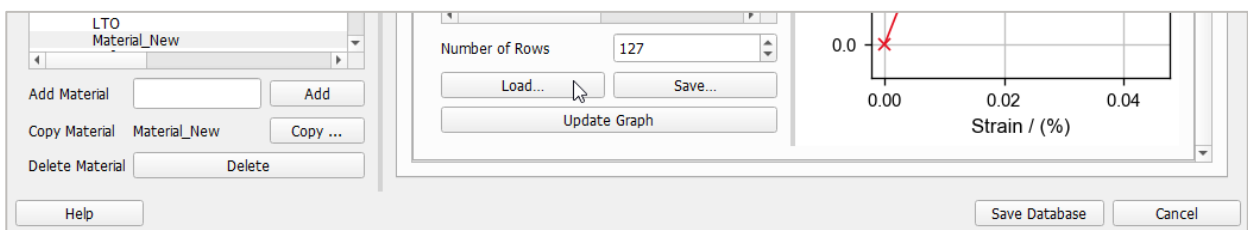

Alternatively, data can also be entered by copy-and-paste or manually and save the data as a *.txt file with the **Save...** button.

To plot the data, click the **Update Graph** button.

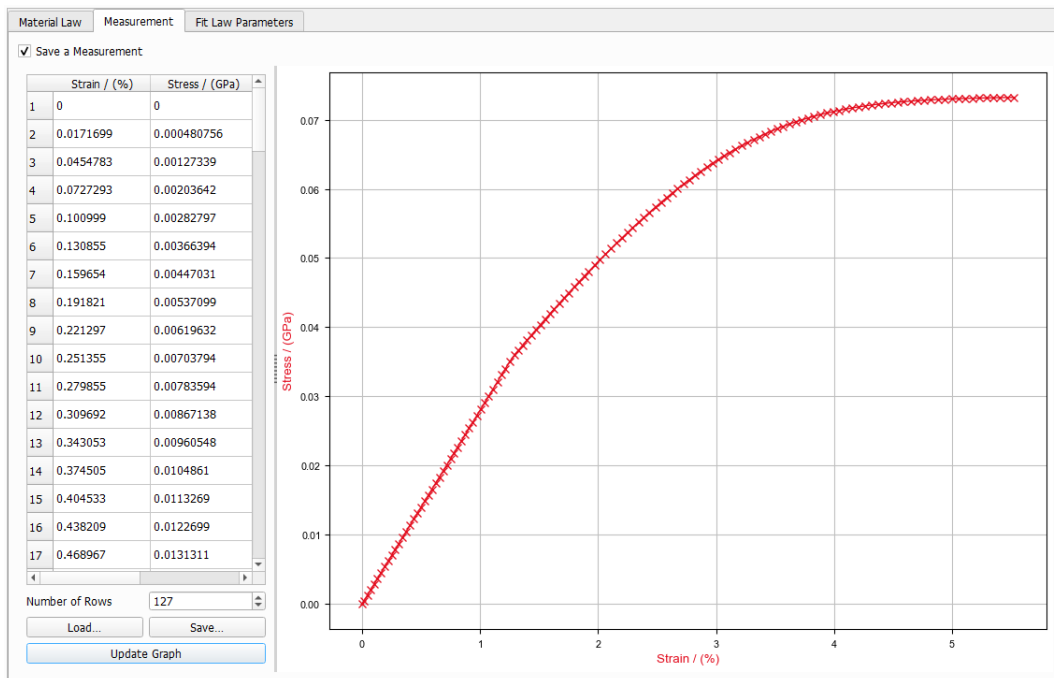

FIT LAW PARAMETERS

To fit the material law, select the **Fit Law Parameters** tab under the current material law. Choose a material law from the pulldown menu:

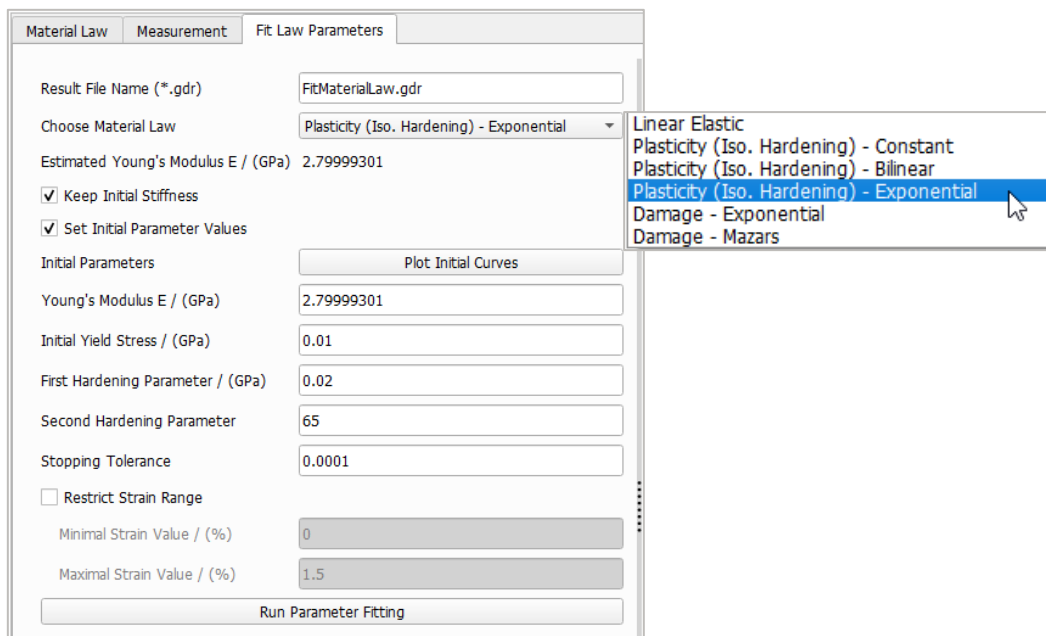

The result is dependent on the start values for the fitting process. Therefore, the initial values can be user defined by checking **Set Initial Parameters** and **Keep Initial Stiffness**.

The quality of the initial values can be checked with **Plot Initial Curves**. It is recommended to try several combinations of initial values to find good start

parameters for the material fitting algorithm. To edit the plot settings, right-click on the plot and choose **Edit Axis Settings**.

The fitting algorithm stops if the error between the fit and the target (which is the measurement curve defined in the Measurement tab) is smaller than a threshold. This threshold can be defined in the **Stopping Tolerance** field.

If only a part of the measurement data should be used for fitting the material laws, a strain range can be selected with **Restrict Strain Range**. This is especially useful if a part of the data contains effects which are not simulated by the selected material law, e.g., damage effects when fitting a material law for plasticity.

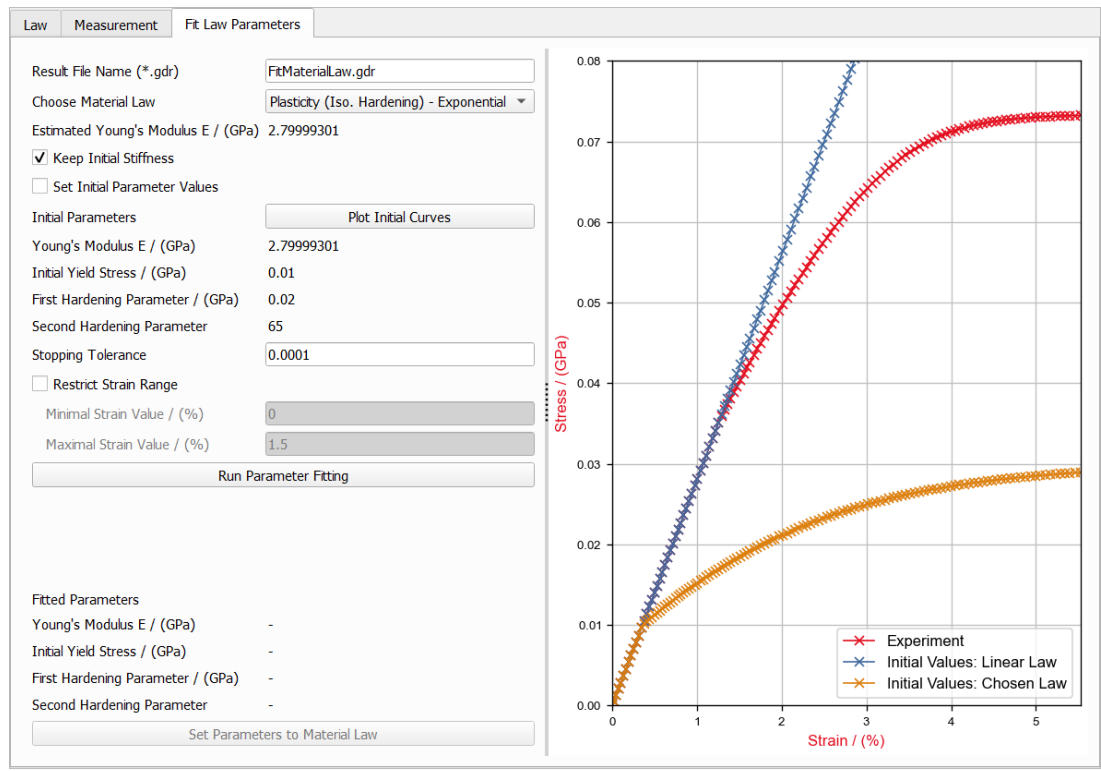

The parameter fitting can be started by clicking **Run Parameter Fitting**. The fitting process will take several seconds, and the results are directly shown in the **Fitted Parameters** section and in the plot.

If the result is not satisfying, the **Initial Parameters** can be adjusted and the parameter fitting process restarted. Another way of improving the result is to reduce the **Stopping Tolerance** and force the fitting algorithm to search longer for a solution.

In the presented example the Initial Yield Stress has to be changed from 0.01 GPa to 0.04 GPa to achieve a good fitting result. In the figure below, you can see that the curve for the exponential plasticity model lays very well over the measurement data after the parameter fit.

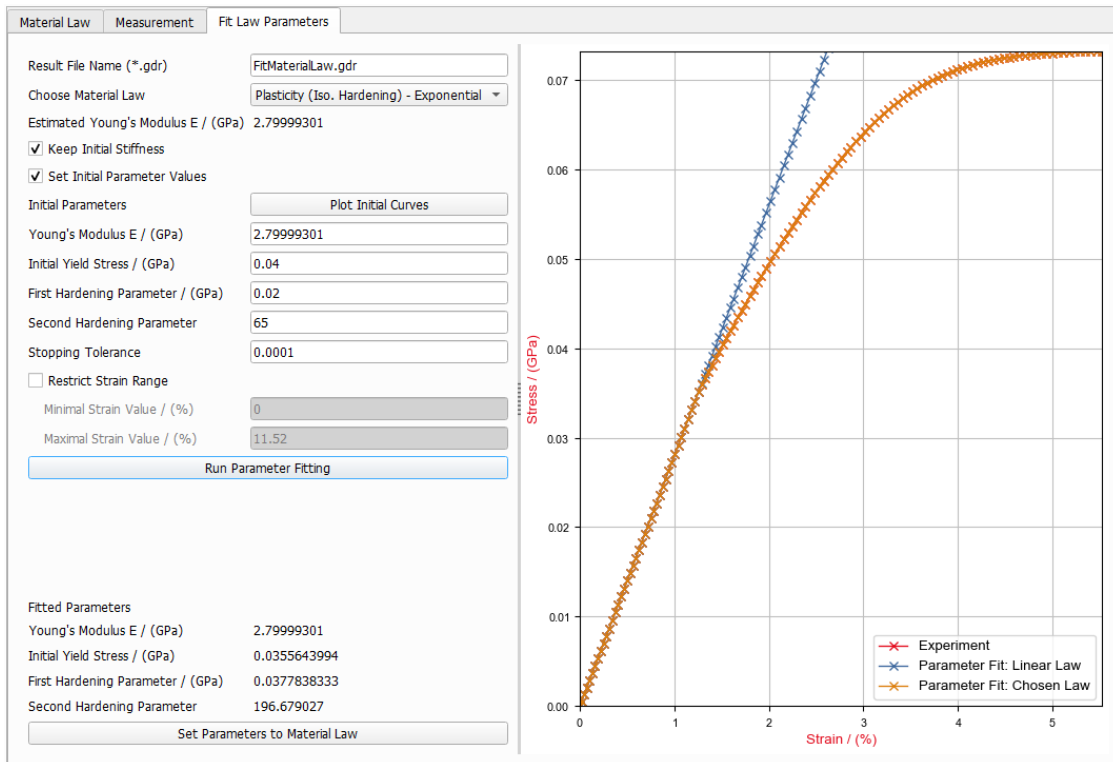

With the button **Set Parameters to Material Law**, the fitted parameters are copied to the material law under the **Material Law** tab.

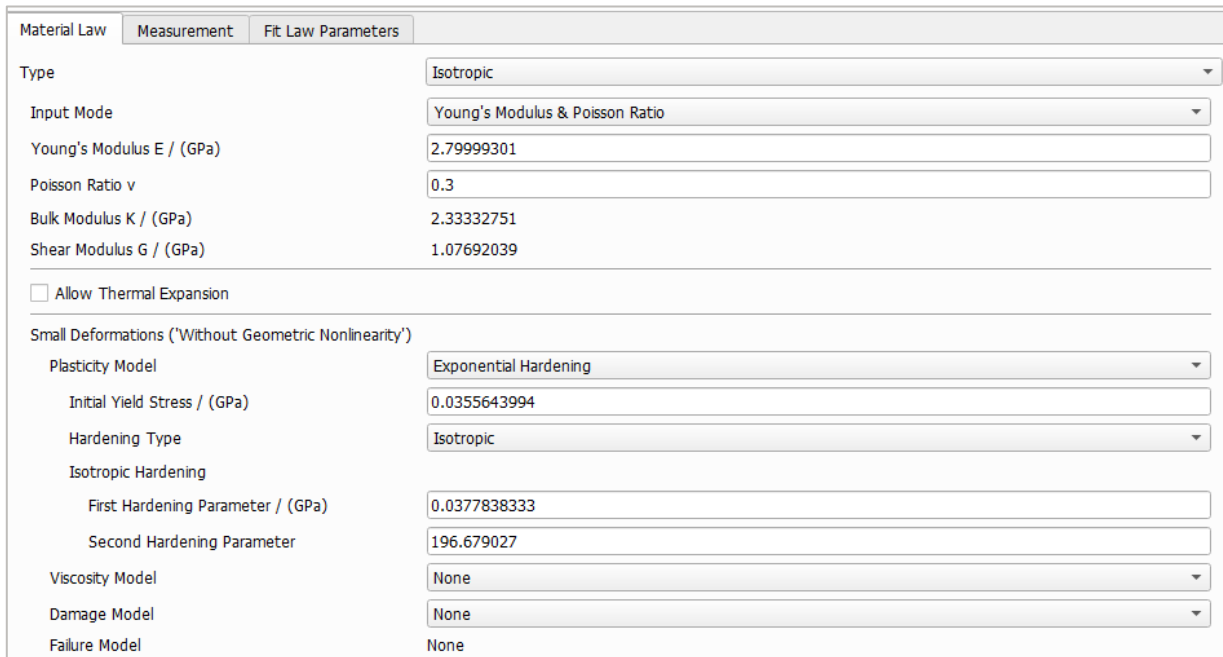

Finally, save the changes to the material database with the **Save Database** button. Now, the new material law is saved and can be used in **ElastoDict**.

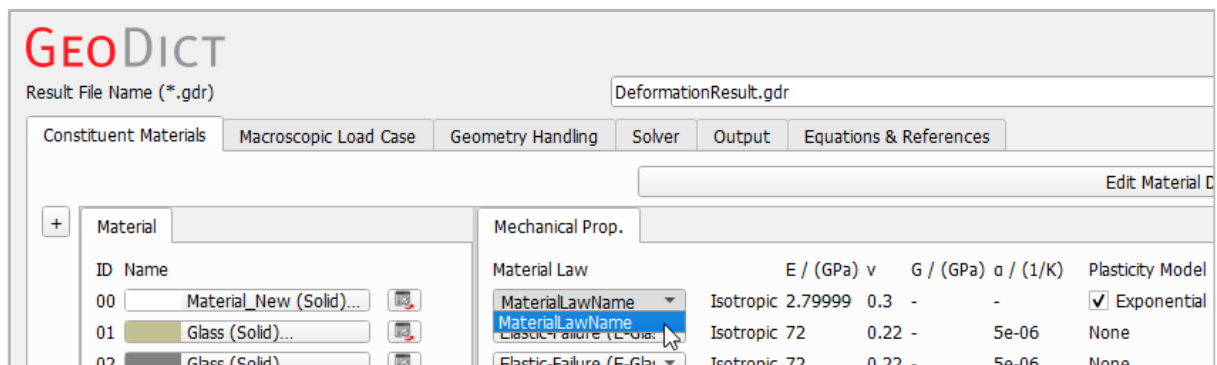

Select the material law (here Material Law1), and make sure that the nonlinear material model is enabled (here: Exponential under **Plasticity Model**).

APPENDIX III: USING UMATs FOR CUSTOM MATERIAL LAWS

The user can program their own user-defined material laws with the UMAT interface in **GeoDict**.

UMATs are a concept from the FEA software Abaqus, and the interface is compatible with **GeoDict**. This means that you can directly use your already existing user materials in **GeoDict**. To get familiar with the syntax, some UMAT files are delivered with **GeoDict**. UMATs are Fortran files (*.f or *.f90), but in **GeoDict** it is also possible to directly use the compiled files (*.so). Nevertheless, *.so files from **GeoDict** 2020 and before cannot be used in **GeoDict** 2021 and later, since the required compiler version changed. Additionally, they might be incompatible between different computers. Therefore, it is important to always keep the source files (*.f or *.f90).

However, if a material can be defined by using the internal material laws (page 116), then we recommend using those instead of UMATs, since they are deeper integrated into **GeoDict** and easier to set up.

EXAMPLE: SETTING UP A MATERIAL LAW FOR DAMAGE USING AN UMAT

This section describes how to set up a material law using an UMAT.

In the menu bar, go to **Settings** and select **Edit Material Data Base...** to access the **GeoDict** Material Database and add a new material to it.

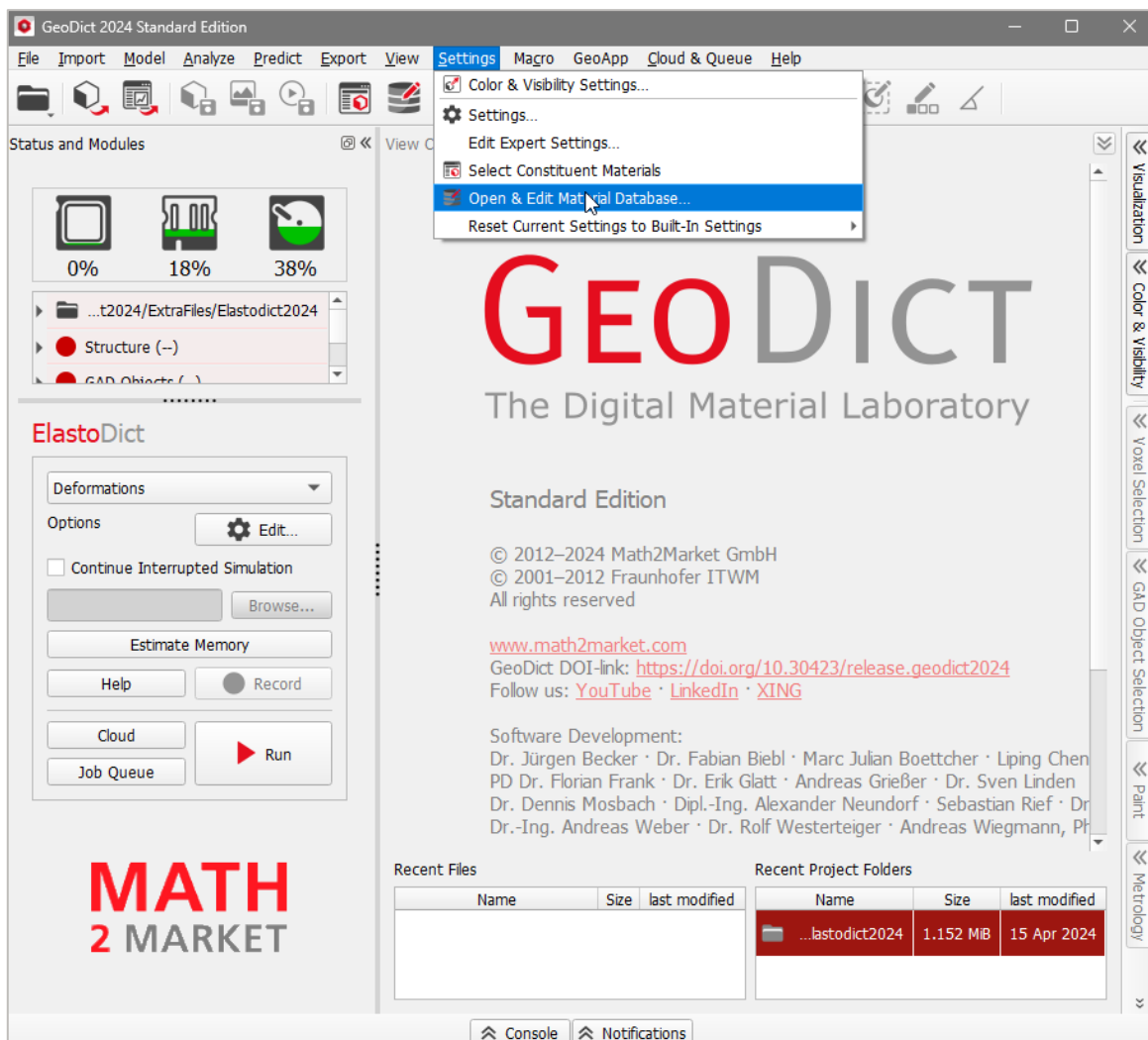

After clicking **Edit Material Data Base...**, the Material Database dialog opens:

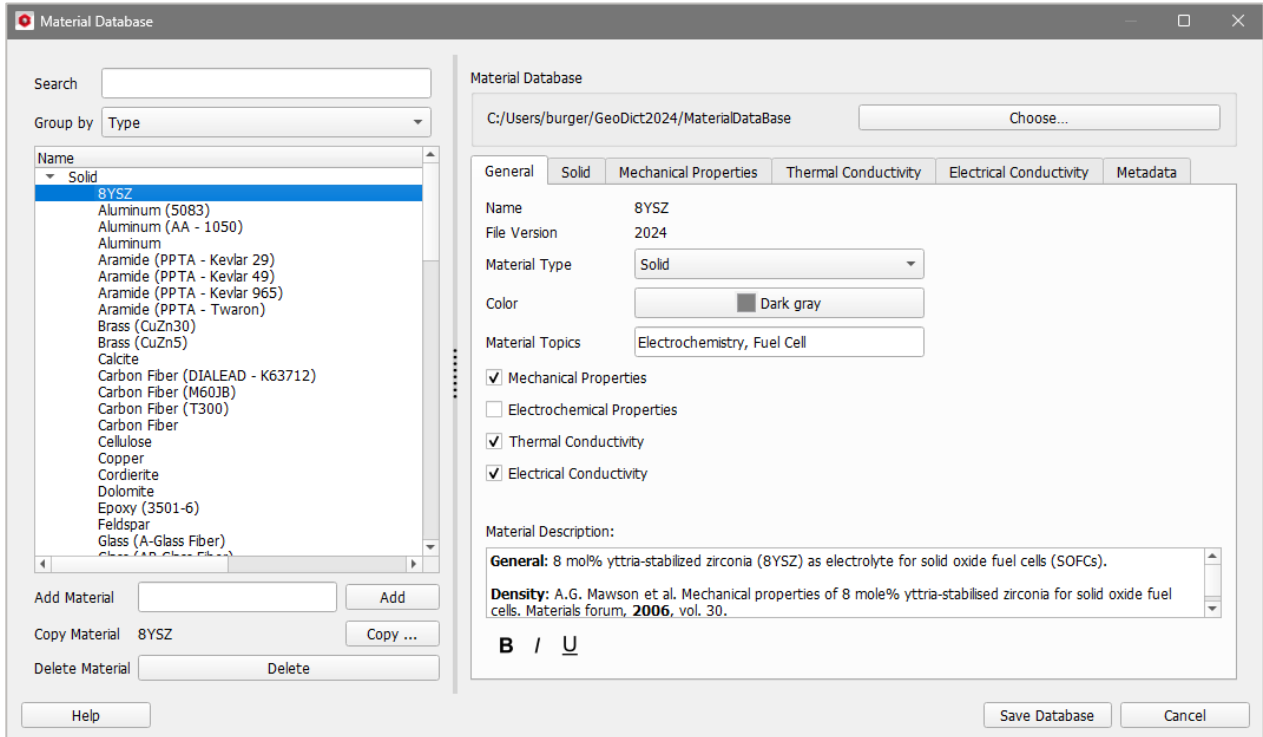

A new material can be added to the database (or a material present in the database can be deleted). To do so, enter a name for the new material (e.g., **Material_New**) and click **Add** in the lower left corner of the **Material Database** dialog.

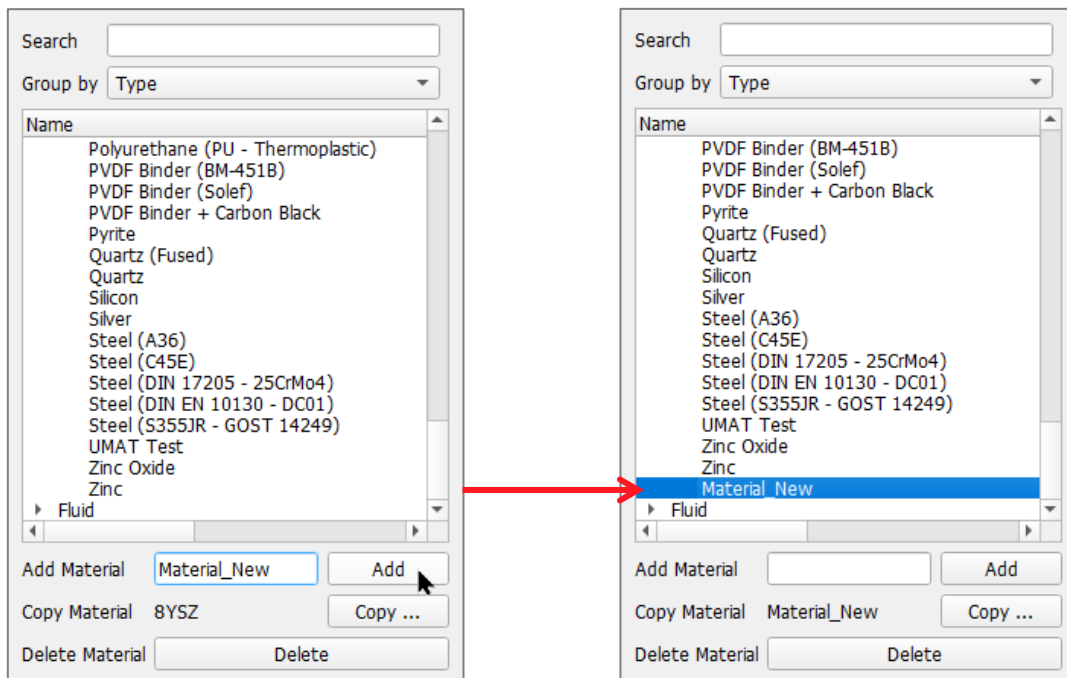

Material_New appears listed in the left panel and default values appear in the right panel.

Under the **General** tab, check **Mechanical Properties** to define those for **Material_New**.

Under the newly appearing **Mechanical** tab, inside the **Mechanical Properties Selection** panel, enter **Damage** in the **Add Material Law** box, and click **Add**.

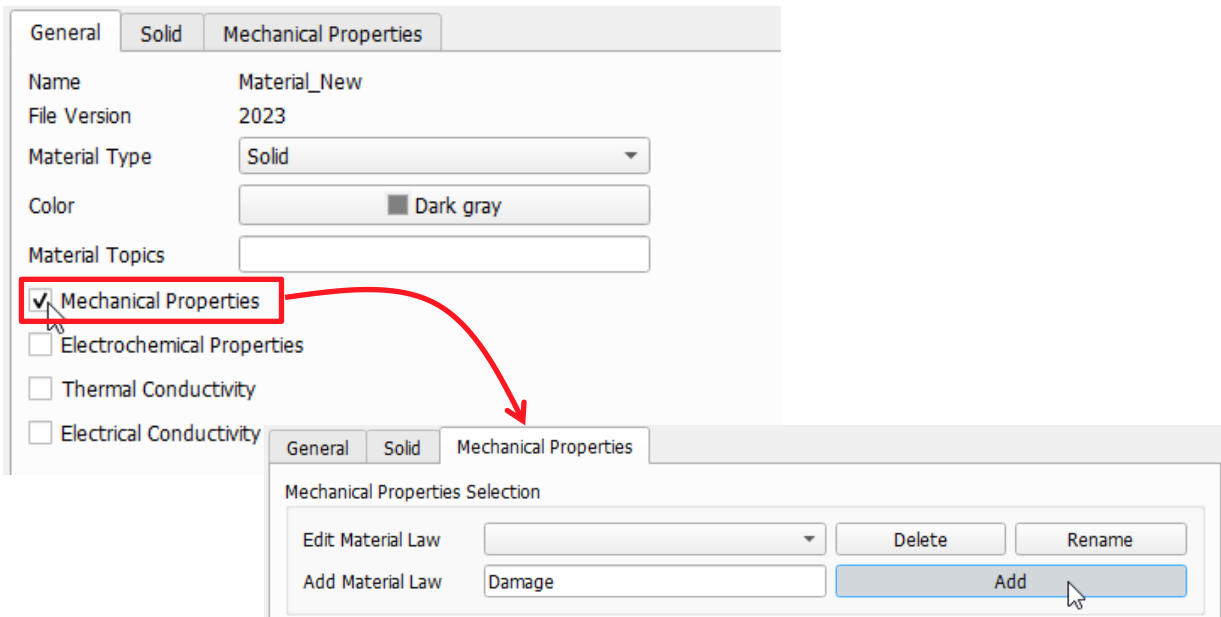

The parameters needed to define the mechanical properties of the new material appear under the panel grouped under the **Law** tab.

From the **Type** pull-down menu, select **UMAT**.

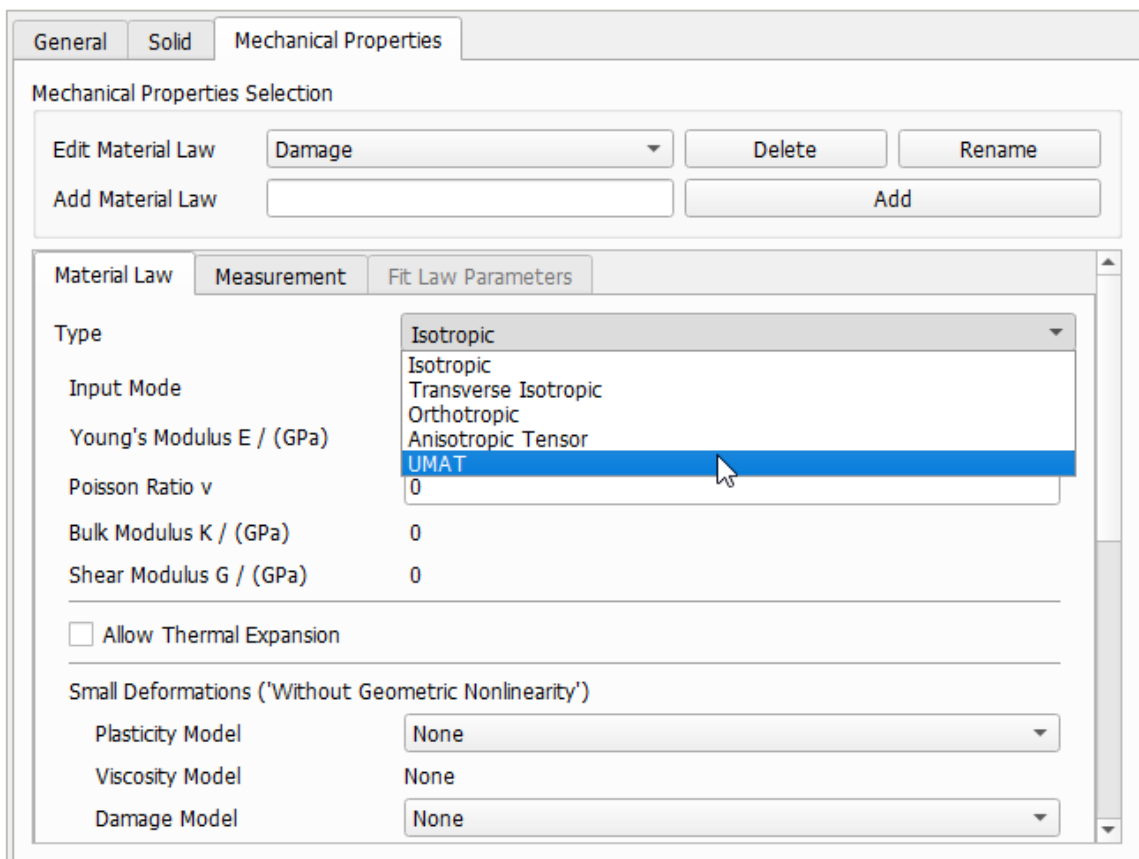

After selecting **UMAT**, a different panel opens below the **Type** pull-down menu, with the **UMAT Parameters**, **Material Parameters**, and **State Variables** tabs.

Under the UMAT Parameters tab, click **Browse** to find the UMATs for **GeoDict 2023** in your user folder. Select the file `IsotropicLinearElasticityDamage.f` UMAT and click **Open**.

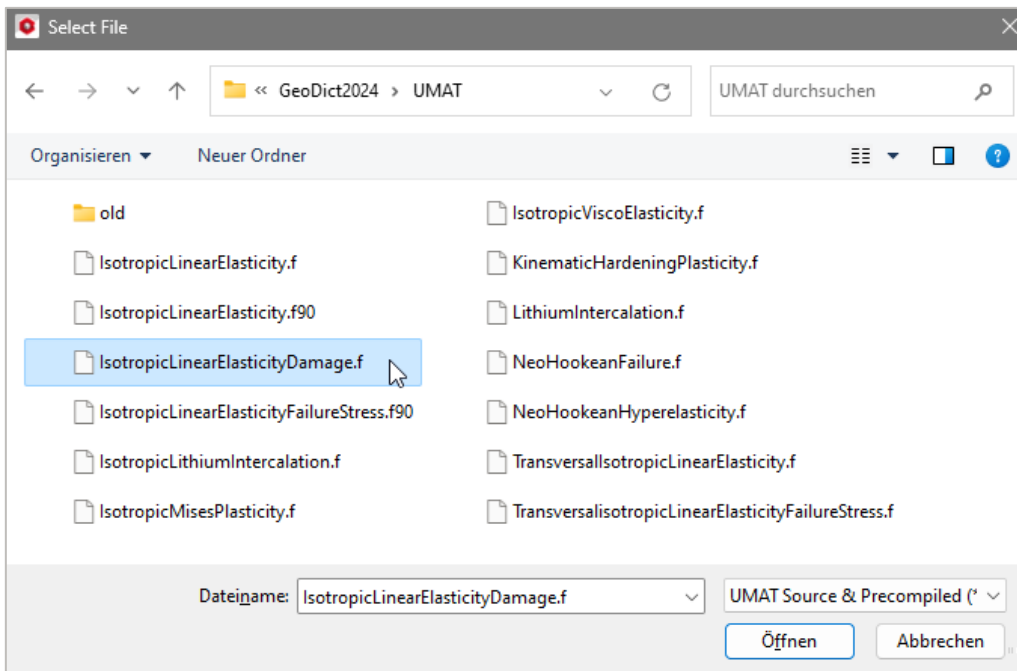

Alternatively, enter a path to the UMAT file relative to the user folder. For this example, this path would be *UMAT/IsotropicLinearElasticityDamage.f*. Relative paths have the advantage that they work independently from your username. Therefore, material database entries can be shared easily between different PCs, as long as the UMAT file is present in the UMAT folder.

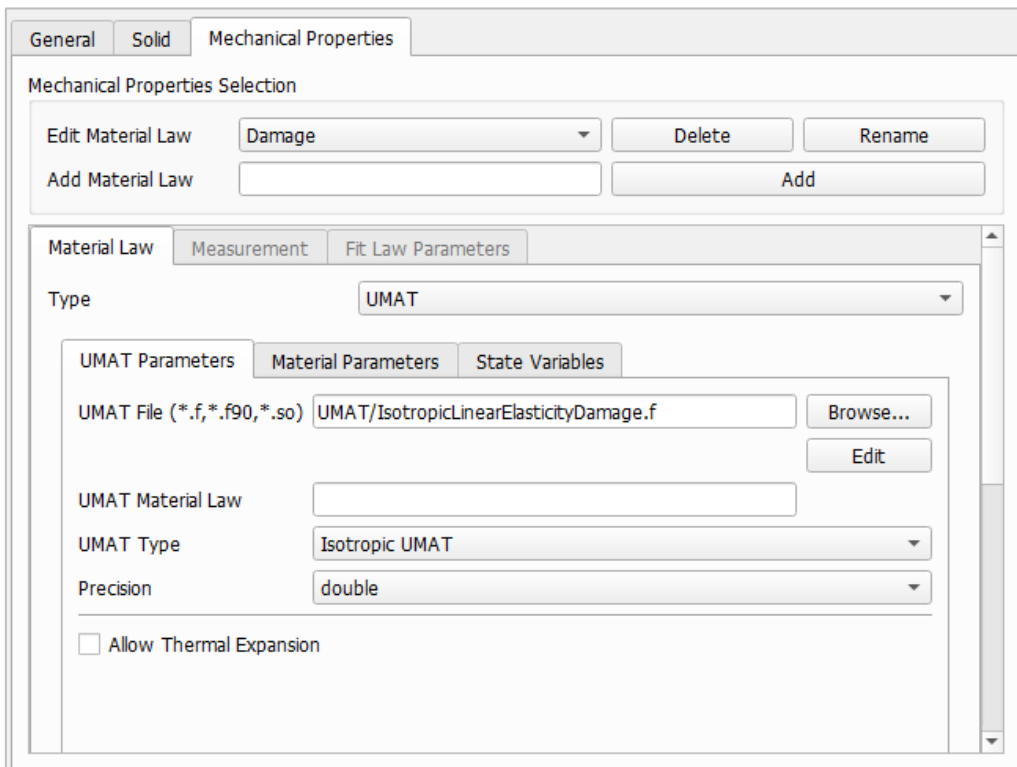

For the material law (defined in the UMAT) to be applied to the **Material_New**, some material parameters must be entered under the **Material Parameters** tab.

These material parameters, that the particular UMAT requires, can be found by opening the UMAT source file, if available (*.f or *.f90). To do so, simply click **Edit**

under the **UMAT Parameters** tab and open it with a text editor (for example, with NotePad++).

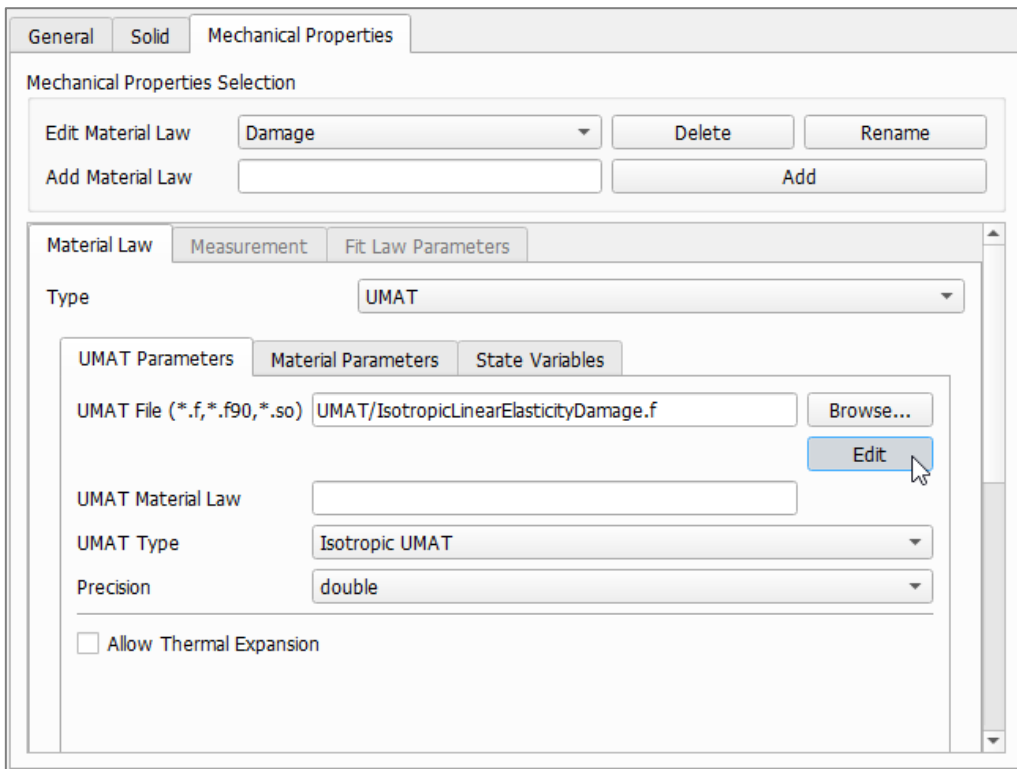

In the opened file, the text shows that applying the *IsotropicLinearElasticityDamage.f* UMAT to **Material_New** requires assigning the following material parameters or properties (PROPS):

- Young's Modulus (E)
- Poisson's Ratio (NU)
- Damage Hardening Modulus (DAMHARD)
- Initial Threshold for the equivalent strain (DAMAGE0).

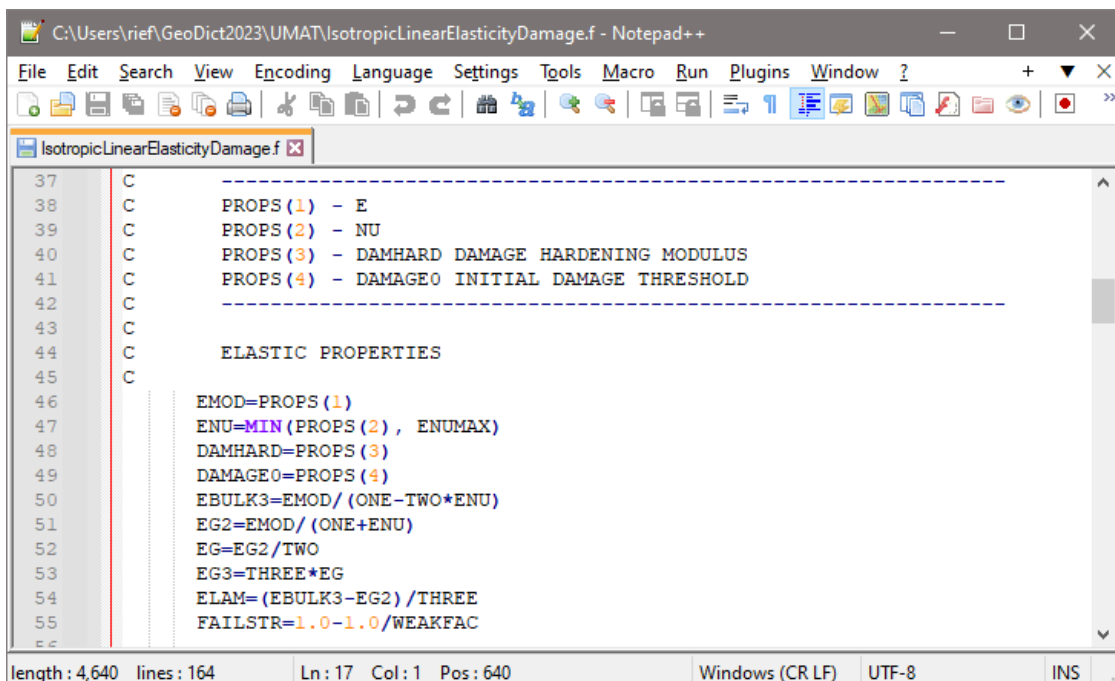

Therefore, in the table under the **Material Parameters** tab, manually enter the needed parameters (Material Parameters), their values for **Material_New** (Value), and a brief parameter explanation (Description). For example, as follows:

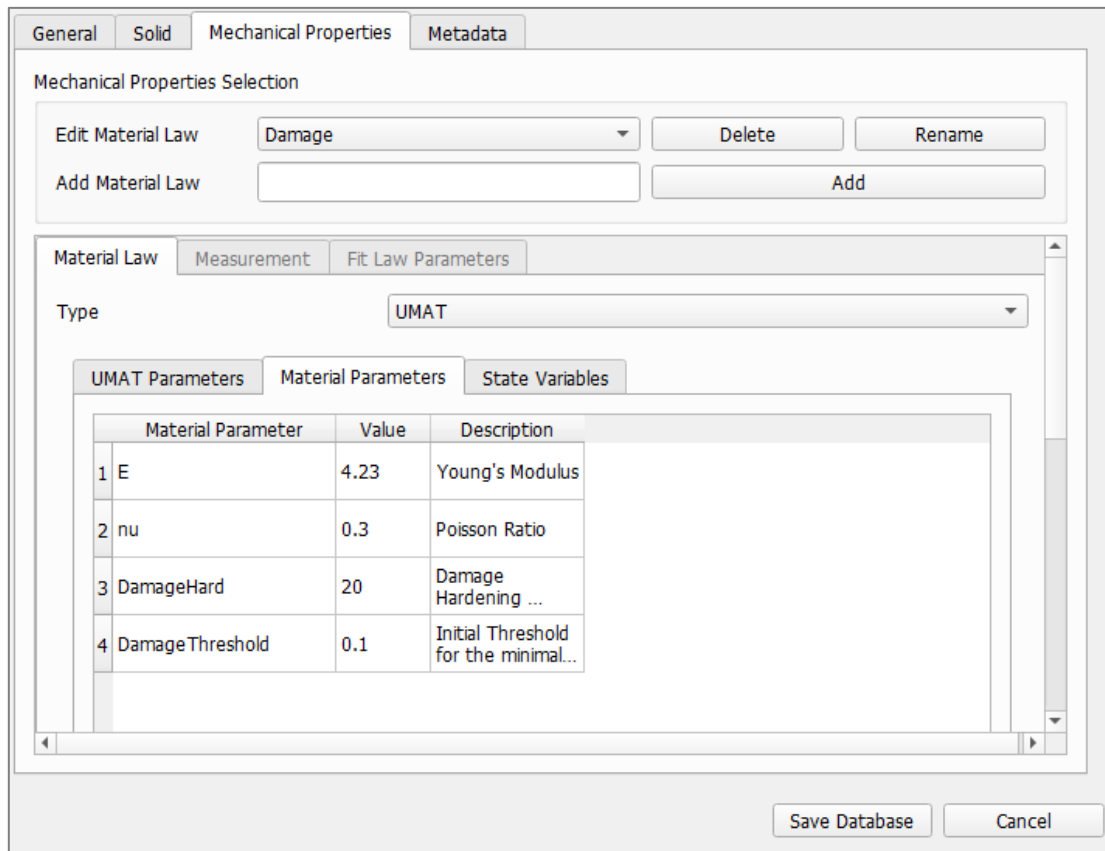

The damage model defined in the *IsotropicLinearElasticityDamage.f* UMAT depends on the equivalent strain, which is calculated as

$$\varepsilon_{eq} = \sqrt{\frac{1}{3} \left(\frac{E}{1-2\nu} - \frac{E}{1+\nu} \right) (\varepsilon_{xx} + \varepsilon_{yy} + \varepsilon_{zz})^2 + \frac{E}{1+\nu} \left[\varepsilon_{xx}^2 + \varepsilon_{yy}^2 + \varepsilon_{zz}^2 + \frac{1}{4} (\varepsilon_{xy}^2 + \varepsilon_{yz}^2 + \varepsilon_{xz}^2) \right]}.$$

The degradation begins as soon as the minimal equivalent strain for damage d_0 is reached:

$$D = 1 - e^{d_1(d_0 - \varepsilon_{eq})}, \quad \varepsilon_{eq} > d_0$$

with d_0 : minimal equivalent strain for damage, d_1 : damage hardening modulus.

Next, go to the **State Variables** tab. State variables are internal variables of the UMAT, they store information which is used in the next iteration. When the State Variables are not properly defined, the UMAT does not work as intended, or it doesn't work at all.

For the UMAT *IsotropicLinearElasticityDamage.f*, there is only one state variable which stores the damage value. It must be defined and initialized with 0, since there is no initial damage in the material. The number of state variables depends on the particular UMAT and is not always obvious. If you need more information about UMATs delivered with [GeoDict](#), ask the [Math2Market](#) support team for help.

Finally, click **Save Database** at the bottom right of the **Edit Material Data-Base** dialog.

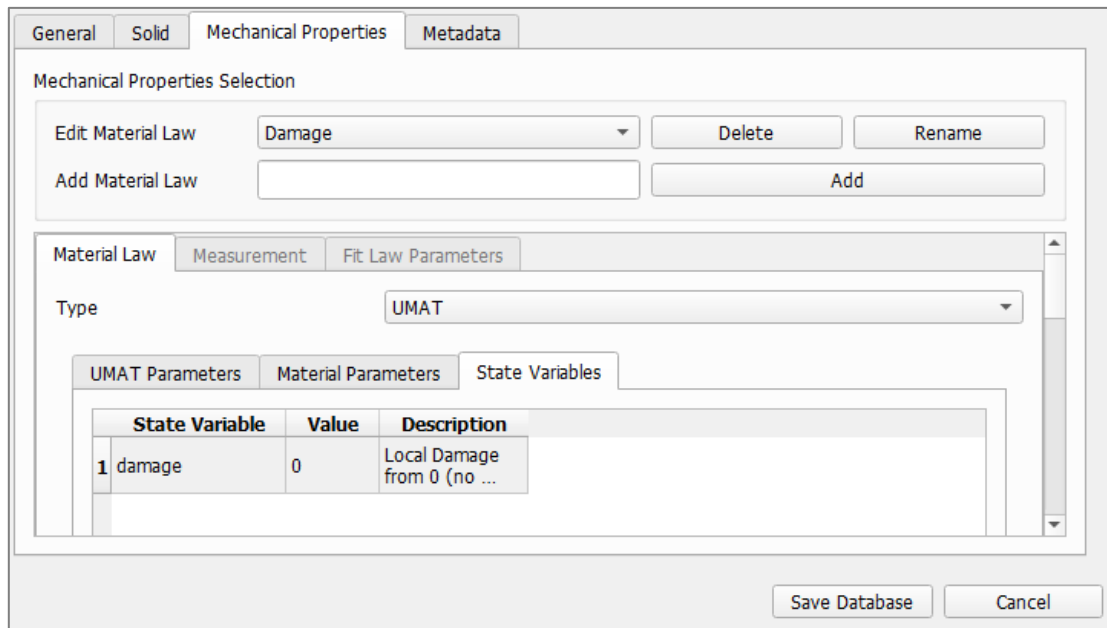

After saving, the newly defined material **Material_New** can be chosen as constituent material when using **ElastoDict**.

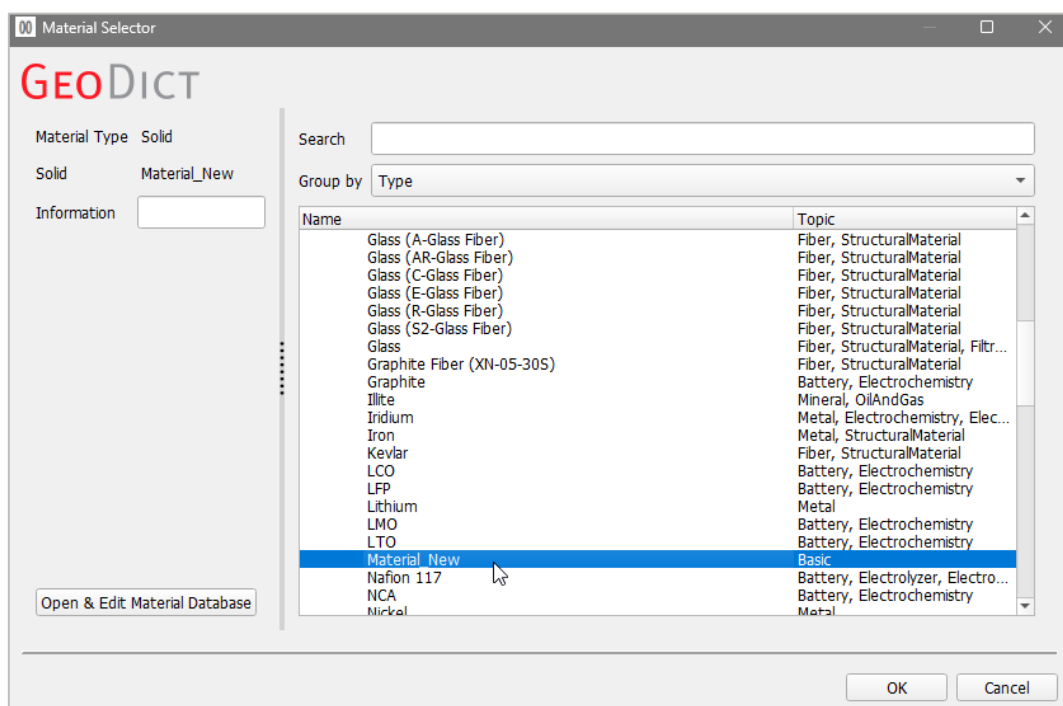
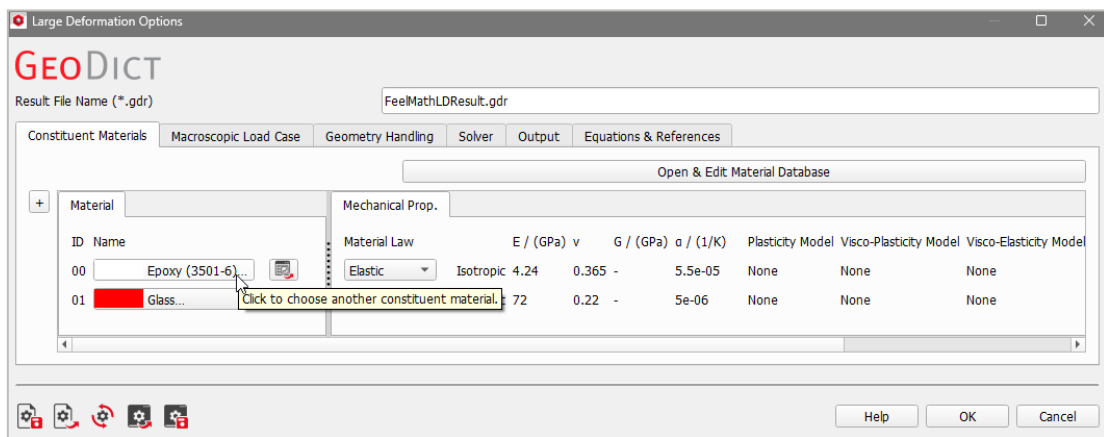

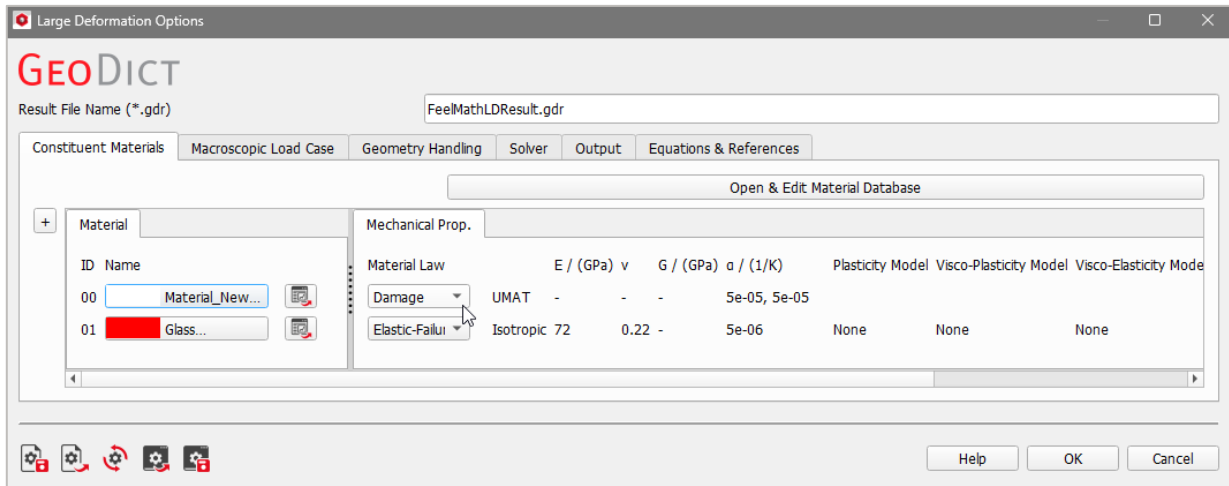

Make sure that the **Damage** material model is selected under Mechanical Properties tab. Now, the material law assigned to **Material_New** is applied in the **ElastoDict** calculations.

EXAMPLE: PLASTIC DEFORMATION WITH A UMAT

Here, another UMAT included with **GeoDict** is used to simulate plastic deformation.

In the **GeoDict** Material Database, the UMAT *IsotropicMisesPlasticity.f* is contained in the database entry for **Aluminum** and appropriate parameters are already defined when choosing **Plastic (UMAT)** and **Type - UMAT** under the **Law** tab.

Besides the linear parameters (Young’s Modulus E; Poisson Ratio ν), it includes a piecewise linear hardening curve that was entered beforehand under the **Mechanical Properties – Material Law - Material Parameters** tab.

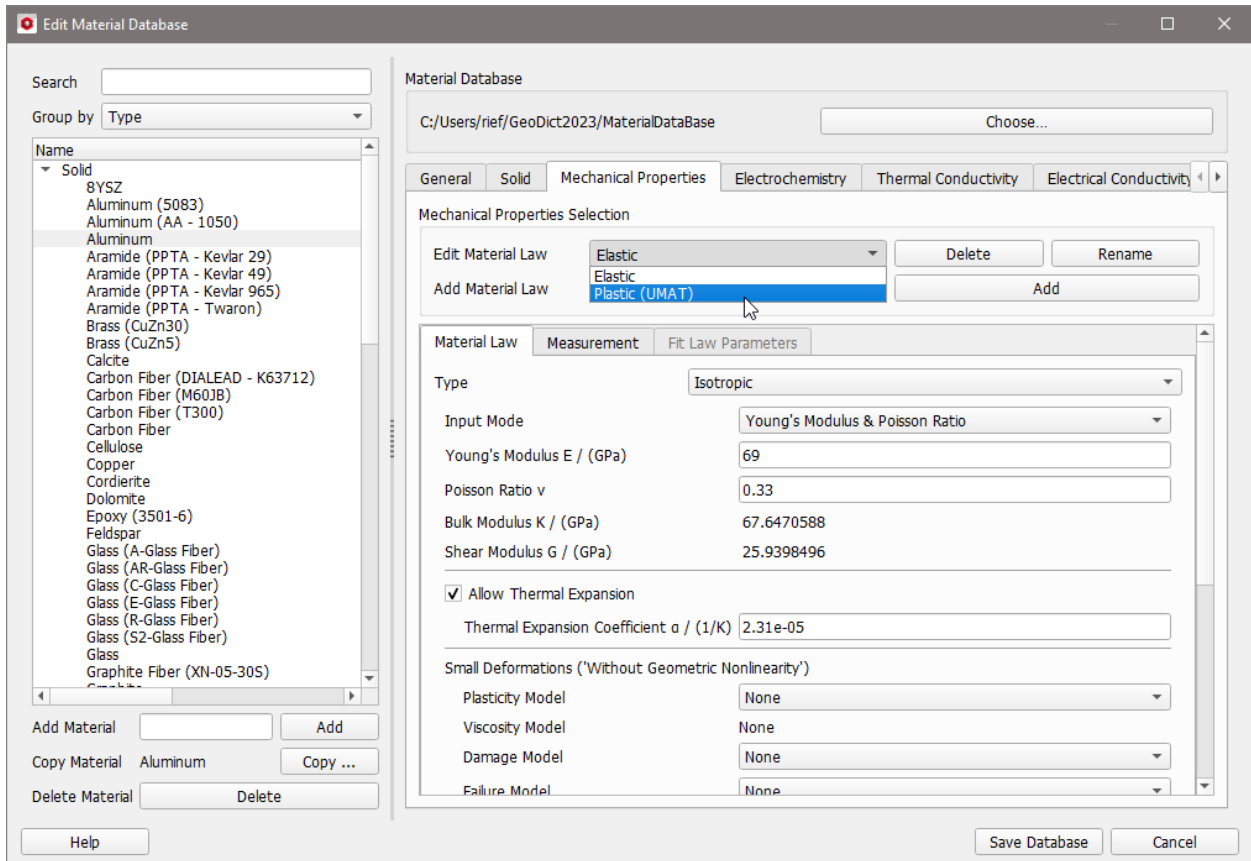

The plastic deformation of aluminum can be simulated in **GeoDict** using a solid block (generated through **Model** → **ProcessGeo** → **Empty & Invert Structure** → **Create Empty Structure**, 1x1x1 voxels, and then, **Model** → **ProcessGeo** → **Empty & Invert Structure** → **Invert Structure**).

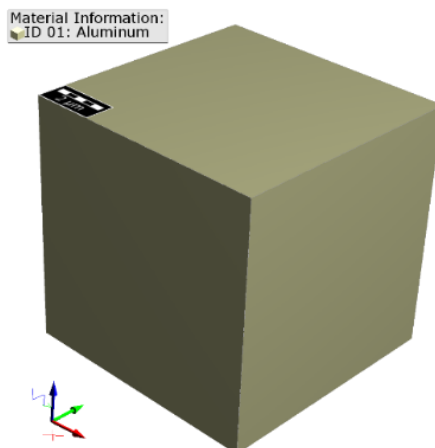

Generally, it is recommended to check the material behavior on small structures. If only a single constituent material must be investigated, a structure consisting of a single voxel is already enough.

In the menu bar, select **Settings** → **Select Constituent Materials**. You can choose the material of the voxel by clicking on the button next to the ID number under the **Material** tab (see screenshot below). In the **Material Selector** dialog, select **Aluminum** from the list of available (Solid) constituent materials.

The color of the constituent material (Aluminum) may be changed via **Settings** → **Color & Visibility Settings**.

The plastic deformation can be examined during a cyclic stress experiment which can be set up in **ElastoDict**. In the menu bar, select **Predict** → **ElastoDict**.

In the **ElastoDict** section, select **Deformations** and click the **Edit...** button. In the **Large Deformations Options** dialog, choose to apply the load in Z-direction in a **Uniaxial Experiment-Tensile**, with **Confined** boundary conditions in tangential direction. Choose the **Load Type** as **Force Controlled**.

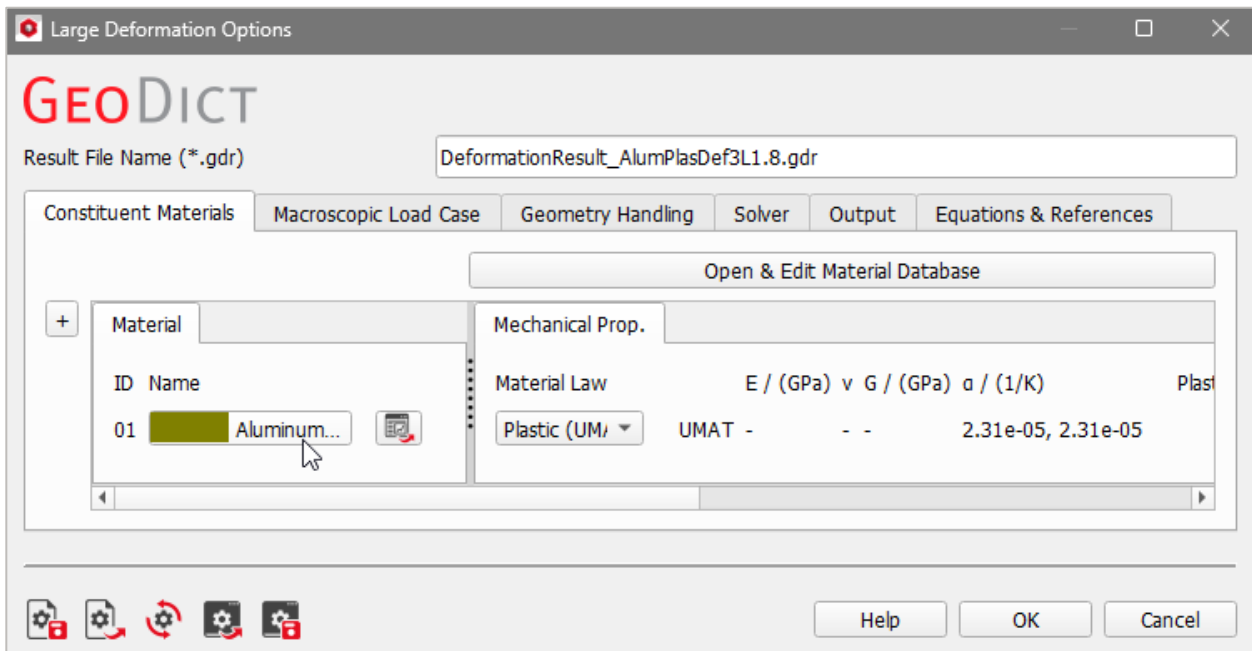

To define a cyclic load, use the **Predefined Shape** option to the right of the **Load Table** (screenshot below).

Choose the **Shape** as **Sawtooth** and the settings as shown in the screenshot.

By clicking **Apply**, the settings for the predefined shape are applied and the load table is defined automatically.

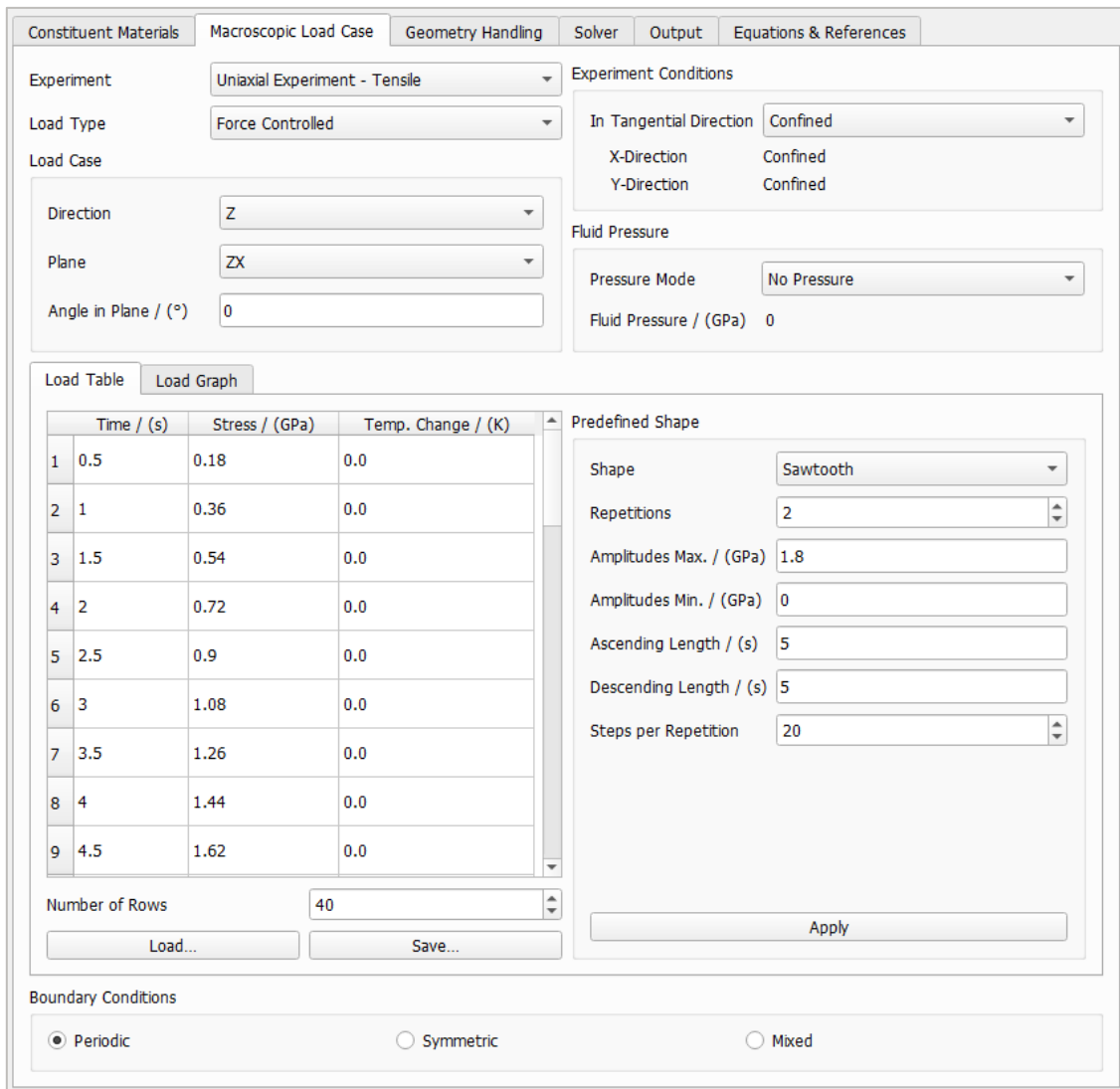

The graph of the load looks as follows:

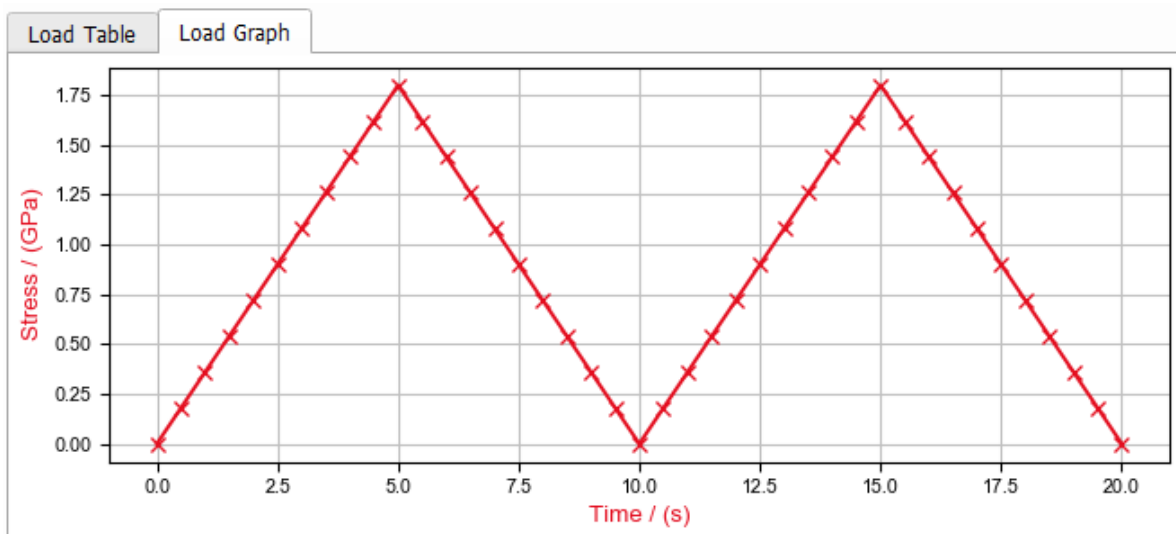

Keep the default settings under the **Geometry Handling** tab.

Under the **Solver** tab, keep the default settings as well: Before **GeoDict 2022**, it was necessary to select the **Memory Efficient (Neumann Series)** when using nonlinear material laws, but this is no longer necessary.

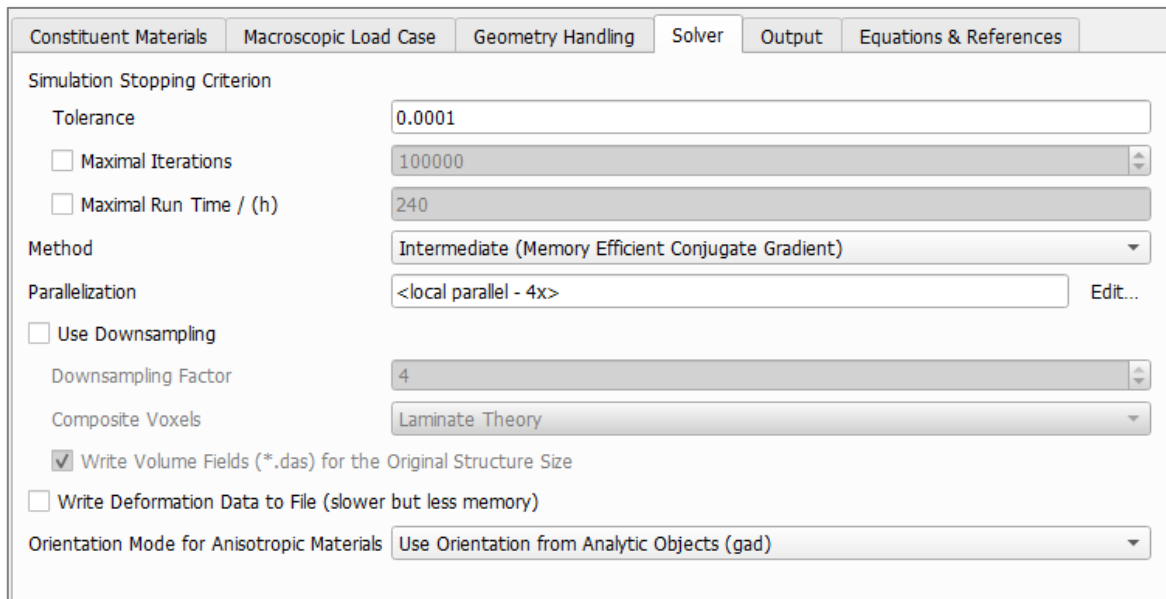

Under the **Output** tab, de-select **Write Deformed Geometry**. In this example, the simulation is done on a structure with only one voxel, and then, the deformed geometry does not provide useful information.

After running the **ElastoDict - Deformations** simulation, the Result Viewer of the result file (.gdr) opens at the **Results** tab. Under the **Results - Plots** subtab, choose to plot the Strain in Z-Direction (%) in the X-Axis against the resulting Stress in Z-Direction (GPa) in the Y-Axis, and click **Apply...**

Observe that the strain does not return to zero after the first load cycle and the plastic deformation remains in the material.

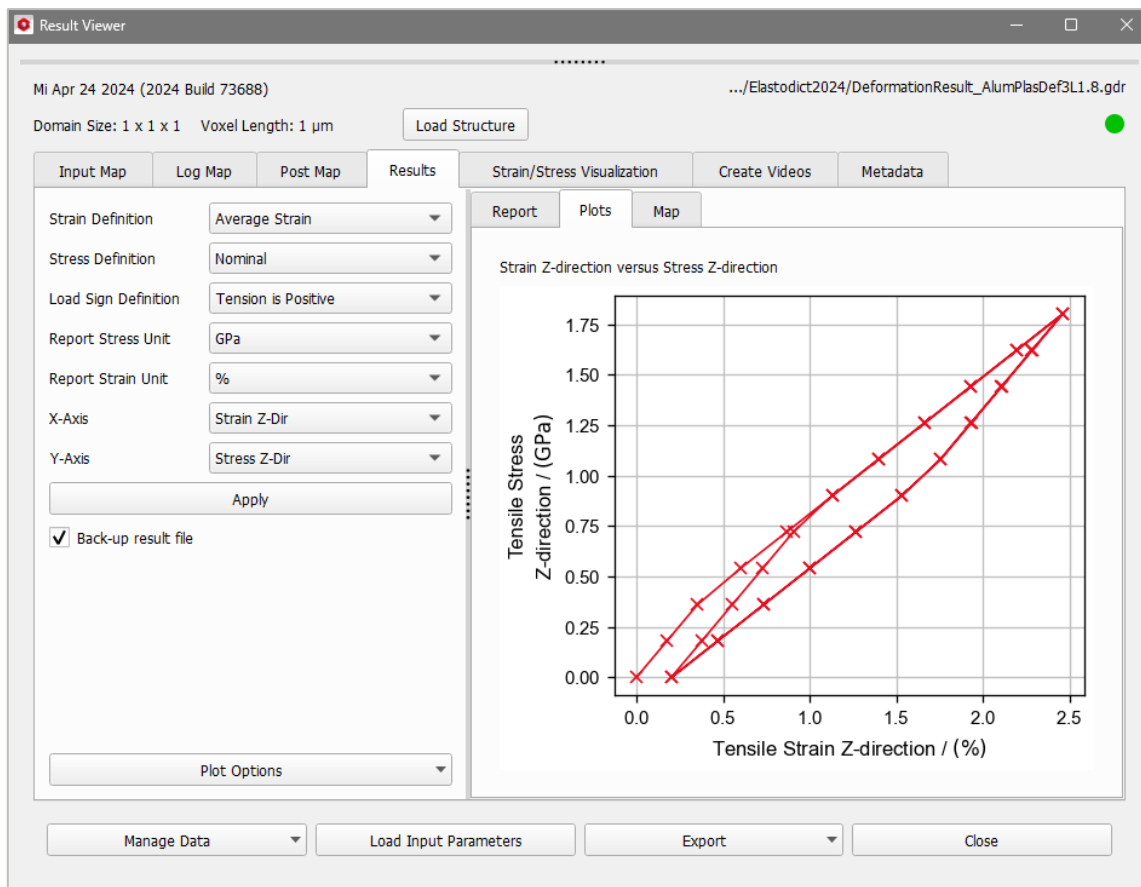

APPENDIX IV: ELASTICITY THEORY

A material is said to be elastic if it deforms under external forces (stress), but returns to its original shape when the stress is removed. For small deformations, the stress is roughly proportional to the strain in many solids. The constant of proportionality between stress and strain is given by the **Young's modulus (E)** which is a measure of *stiffness*. This linear relationship between stress and strain is called Hooke's law and is the basis for the *theory of linear elasticity*.

The general relationship (generalized Hooke's law) between multi-axial stress and strain is described by using 2nd order tensors for stress and strain and the 4th order *elasticity tensor* for their relation.

In solid mechanics, the **Young's modulus E** can be experimentally determined from the slope of a stress-strain curve created during tensile tests conducted on a test specimen of the material. Most metals and ceramics are isotropic. i.e., their mechanical properties are the same in all directions.

If e.g., metals are treated in a special way for example by deep drawing, they become anisotropic, so that the **Young's modulus** depends on the direction from which the force is applied. Some materials, which are composites of two or more constituents, such as wood or reinforced concrete, are strongly anisotropic materials and display widely different mechanical properties when load is applied in different directions. For example, they exhibit a higher Young's modulus (stiffness) when loaded parallel to the fibers. This is true under the assumption that the fibers have a higher **Young's modulus** than the surrounding matrix material.

Based on the input parameters, **GeoDict** solves six load cases or experiments (three compressions in x, y and z, and three shearing experiments) which are sequentially computed by the **ElastoDict** solver to predict the entries of the 6x6 effective elasticity tensor. Each of these six simulations is done by assigning load case-specific displacements on the boundaries of the structure and calculating the corresponding stresses. By averaging the stresses over the structure, the **Hooke's Law** in the general anisotropic case is obtained,

$$\sigma_{ij} = \sum_{r,s=1}^3 c_{ijrs} \varepsilon_{rs}, \quad i, j \in \{1, 2, 3\}$$

where c is a symmetric fourth order tensor, called also *elasticity tensor*. Usually, the elasticity tensor and the stresses and strains are written in *Voigt notation* (see [Wikipedia](#)). This way, the elasticity tensor is reduced to a 6x6 matrix, and the stresses and strains are written as 6x1 vectors. This leads to a more compact and readable notation.

Because of these symmetry properties, it is convenient to use the so-called "*reduced suffix notation*" (e.g., Chadwick et. al.) with the following index assignment:

Tensor notation Index ij	11	22	33	23, 32	31, 13	12, 21
denoted also by	xx	yy	zz	yz	zx	xy
Voigt notation index I	1	2	3	4	5	6

Then, taking into account also the symmetry of the elasticity tensor,

$$c_{ijkl} = c_{jikl} = c_{ijlk} = c_{klij}, \quad i, j, k, l \in \{1,2,3\}$$

The stress tensor σ_{ij} can be written as σ_I in Voigt notation:

$$\sigma = \begin{pmatrix} \sigma_{11} \\ \sigma_{22} \\ \sigma_{33} \\ \sigma_{23} \\ \sigma_{31} \\ \sigma_{12} \end{pmatrix}$$

The strain tensor ε_{ij} can be written as ε_I in Voigt notation:

$$\varepsilon = \begin{pmatrix} \varepsilon_{11} \\ \varepsilon_{22} \\ \varepsilon_{33} \\ \varepsilon_{23} \\ \varepsilon_{31} \\ \varepsilon_{12} \end{pmatrix}$$

With the Voigt notation, the symmetric fourth order elasticity tensor c_{ijkl} can be reduced to a symmetric matrix C_{IJ} with the following entries (coefficients):

$C_{11}=C_{1111}=C_{xxxx}$	$C_{12}=C_{1122}=C_{xxyy}$	$C_{13}=C_{1133}=C_{xxzz}$	$C_{14}=C_{1123}=C_{xxyy}$	$C_{15}=C_{1131}=C_{xxzx}$	$C_{16}=C_{1112}=C_{xxyy}$
	$C_{22}=C_{2222}=C_{yyyy}$	$C_{23}=C_{2233}=C_{yyzz}$	$C_{24}=C_{2223}=C_{yyyz}$	$C_{25}=C_{2231}=C_{yyzx}$	$C_{26}=C_{2212}=C_{yyxy}$
		$C_{33}=C_{3333}=C_{zzzz}$	$C_{34}=C_{3323}=C_{zzyz}$	$C_{35}=C_{3331}=C_{zzzx}$	$C_{36}=C_{3312}=C_{zzxy}$
			$C_{44}=C_{2323}=C_{yzyz}$	$C_{45}=C_{2331}=C_{yzzx}$	$C_{46}=C_{2312}=C_{yzyx}$
				$C_{55}=C_{3131}=C_{zxzx}$	$C_{56}=C_{3112}=C_{zxxy}$
					$C_{66}=C_{1212}=C_{xyxy}$

Therefore, the generalized Hooke's law can be written as a matrix-vector product:

$$\sigma_I = \sum_{J=1}^6 C_{IJ} \varepsilon_J, \quad I = 1, \dots, 6$$

$$\begin{pmatrix} \sigma_{xx} \\ \sigma_{yy} \\ \sigma_{zz} \\ \sigma_{yz} \\ \sigma_{xz} \\ \sigma_{xy} \end{pmatrix} = \begin{pmatrix} C_{11} & C_{12} & C_{13} & C_{14} & C_{15} & C_{16} \\ C_{12} & C_{22} & C_{23} & C_{24} & C_{25} & C_{26} \\ C_{13} & C_{23} & C_{33} & C_{34} & C_{35} & C_{36} \\ C_{14} & C_{24} & C_{34} & C_{44} & C_{45} & C_{46} \\ C_{15} & C_{25} & C_{35} & C_{45} & C_{55} & C_{56} \\ C_{16} & C_{26} & C_{36} & C_{46} & C_{56} & C_{66} \end{pmatrix} \begin{pmatrix} \varepsilon_{xx} \\ \varepsilon_{yy} \\ \varepsilon_{zz} \\ 2\varepsilon_{yz} \\ 2\varepsilon_{xz} \\ 2\varepsilon_{xy} \end{pmatrix}$$

σ : stress tensor C : elasticity or stiffness tensor ε : deformation tensor

This elasticity or stiffness tensor describes the most general stress-strain relations for a linear elastic anisotropic solid (e.g., triclinic solid which has no material symmetry, *Nayfeh, A.H. 1995*).

According to [Nayfeh](#), the constitutive relations for the different symmetry classes can be listed as follows:

Symmetry class	Number of parameters to define material	Form of elasticity tensor
Anisotropic (triclinic or general)	21 ($C_{11}, C_{12}, C_{13}, C_{14}, C_{15}, C_{16}, C_{22}, C_{23}, C_{24}, C_{25}, C_{26}, C_{33}, C_{34}, C_{35}, C_{36}, C_{44}, C_{45}, C_{46}, C_{55}, C_{56}, C_{66}$)	$C_{\text{anisotropic}} = \begin{pmatrix} C_{11} & C_{12} & C_{13} & C_{14} & C_{15} & C_{16} \\ C_{12} & C_{22} & C_{23} & C_{24} & C_{25} & C_{26} \\ C_{13} & C_{23} & C_{33} & C_{34} & C_{35} & C_{36} \\ C_{14} & C_{24} & C_{34} & C_{44} & C_{45} & C_{46} \\ C_{15} & C_{25} & C_{35} & C_{45} & C_{55} & C_{56} \\ C_{16} & C_{26} & C_{36} & C_{46} & C_{56} & C_{66} \end{pmatrix}$
Monoclinic	13 ($C_{11}, C_{12}, C_{13}, C_{16}, C_{22}, C_{23}, C_{26}, C_{33}, C_{36}, C_{44}, C_{45}, C_{55}, C_{56}, C_{66}$)	$C_{\text{monoclinic}} = \begin{pmatrix} C_{11} & C_{12} & C_{13} & 0 & 0 & C_{16} \\ C_{12} & C_{22} & C_{23} & 0 & 0 & C_{26} \\ C_{13} & C_{23} & C_{33} & 0 & 0 & C_{36} \\ 0 & 0 & 0 & C_{44} & C_{45} & 0 \\ 0 & 0 & 0 & C_{45} & C_{55} & 0 \\ C_{16} & C_{26} & C_{36} & 0 & 0 & C_{66} \end{pmatrix}$
Orthotropic	9 ($C_{11}, C_{12}, C_{13}, C_{22}, C_{23}, C_{33}, C_{44}, C_{55}, C_{66}$)	$C_{\text{orthotropic}} = \begin{pmatrix} C_{11} & C_{12} & C_{13} & 0 & 0 & 0 \\ C_{12} & C_{22} & C_{23} & 0 & 0 & 0 \\ C_{13} & C_{23} & C_{33} & 0 & 0 & 0 \\ 0 & 0 & 0 & C_{44} & 0 & 0 \\ 0 & 0 & 0 & 0 & C_{55} & 0 \\ 0 & 0 & 0 & 0 & 0 & C_{66} \end{pmatrix}$
Transversely Isotropic	5 ($C_{11}, C_{12}, C_{13}, C_{33}, C_{44}$)	$C_{\text{transv.isotropic}} = \begin{pmatrix} C_{11} & C_{12} & C_{13} & 0 & 0 & 0 \\ C_{12} & C_{11} & C_{13} & 0 & 0 & 0 \\ C_{13} & C_{13} & C_{33} & 0 & 0 & 0 \\ 0 & 0 & 0 & C_{44} & 0 & 0 \\ 0 & 0 & 0 & 0 & C_{44} & 0 \\ 0 & 0 & 0 & 0 & 0 & \frac{C_{11} - C_{12}}{2} \end{pmatrix}$
Cubic	3 (C_{11}, C_{12}, C_{66})	$C_{\text{cubic}} = \begin{pmatrix} C_{11} & C_{12} & C_{12} & 0 & 0 & 0 \\ C_{12} & C_{11} & C_{12} & 0 & 0 & 0 \\ C_{12} & C_{12} & C_{11} & 0 & 0 & 0 \\ 0 & 0 & 0 & C_{66} & 0 & 0 \\ 0 & 0 & 0 & 0 & C_{66} & 0 \\ 0 & 0 & 0 & 0 & 0 & C_{66} \end{pmatrix}$
Isotropic	2 (C_{11}, C_{12})	$C_{\text{iso}} = \begin{pmatrix} C_{11} & C_{12} & C_{12} & 0 & 0 & 0 \\ C_{12} & C_{11} & C_{12} & 0 & 0 & 0 \\ C_{12} & C_{12} & C_{11} & 0 & 0 & 0 \\ 0 & 0 & 0 & \frac{C_{11} - C_{12}}{2} & 0 & 0 \\ 0 & 0 & 0 & 0 & \frac{C_{11} - C_{12}}{2} & 0 \\ 0 & 0 & 0 & 0 & 0 & \frac{C_{11} - C_{12}}{2} \end{pmatrix}$

The 6x6 matrix C_{IJ} for the homogeneous material “nearest” to the inhomogeneous original material is shown in the *.gdr result file after the solver has finished the stiffness estimation computations.

When using ElastoDict with linear laws for the constituent materials, it is important to keep in mind that the elasticity solver is working in the range of linear elasticity. To compute large deformations, plastic yield, damage effects, possible crack initiation, crack growth, and other nonlinear effects one has to use nonlinear material laws, which describe the effects under consideration, for the constituent materials. For such cases, the Hooke’s law does not hold.

Nonlinear materials, e.g., for plastic deformation and damage laws are described in Appendix II on page 101ff. Additionally, nonlinear material laws can be defined by an Abaqus UMAT, see page 114 for further details. With the GeoDict installation several examples for UMATs are available.

REFERENCES

J.T. Browaeys and S. Chevrot: **Decomposition of the elastic tensor and geophysical applications.** *Geophys. J. Int.* (2004) **159**, pp. 667-678.

P. Chadwick, M Vianello and S.C. Cowin: **A new proof that the number of linear elastic symmetries is eight.** *Journal of Mechanics and Physics of Solids*, **49** (2001), pp. 2471 – 2492.

A.H. Nayfeh: **Wave propagation in layered anisotropic media with applications to composites.** *Elsevier Science, North-Holland series in Applied Mathematics and Mechanics*, Vol. 39, 1995.

V. Rutka and A. Wiegmann: **Explicit Jump Immersed Interface Method for virtual material design of the effective elastic moduli of composite materials.** *Technical Report of the Fraunhofer ITWM*, No. 73 (2005).

V. Rutka, A. Wiegmann, and H. Andrä: **EJIIM for Calculation of effective Elastic Moduli in 3D.** *Technical Report of the Fraunhofer ITWM* No. 93 (2006)

Wikipedia: Hooke’s law. https://en.wikipedia.org/wiki/Hooke's_law

APPENDIX V: EFFECTIVE ELASTIC PROPERTIES

To demonstrate and discuss different **ElastoDict**'s effective elastic properties, **ElastoDict-Effective Stiffness** computation results for two different fiber-reinforced composite structures are presented. The structures were generated with the **FiberGeo** module with [isotropic](#) and [transverse isotropic](#) fiber orientations.

Both composite structures contain the same type of fiber (curved elliptical, diameter $6\ \mu\text{m}$), at the same solid volume percentage, but differ in their fiber orientation. The isotropic structure has been generated with isotropic fiber orientation, while transverse isotropic structure has been generated with $Anisotropy\ 1 = 1$ and $Anisotropy\ 2 = 10$.

For more information on generating isotropic and anisotropic structures, see the [FiberGeo](#) handbook.

Isotropic structure

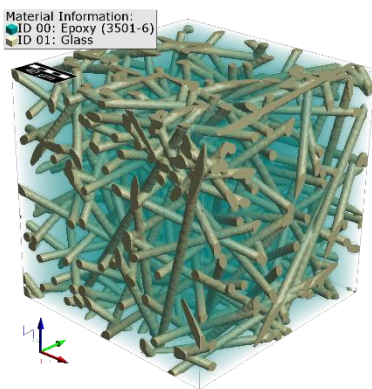

Transverse isotropic structure

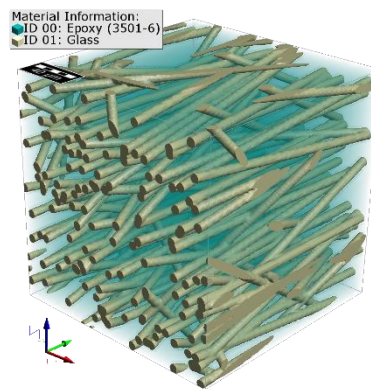

Here, already knowing that the fibers in the structure are isotropic or anisotropic helps explaining how to interpret the results obtained with **ElastoDict**. However, the true power of the **ElastoDict** analysis lies in cases where the orientation of the media is not known in advance, such as imported segmented 3D-images obtained from CT (Computed Tomography) scans.

The two composite structures generated with **FiberGeo**, can be loaded for further simulations by selecting **File** → **Open Structure (*.gdt, *.gad)...** in the menu bar.

To start **ElastoDict**, **Predict** → **ElastoDict** has to be chosen in the menu bar. For each of the two runs, **Effective Stiffness** from the pull-down menu is selected.

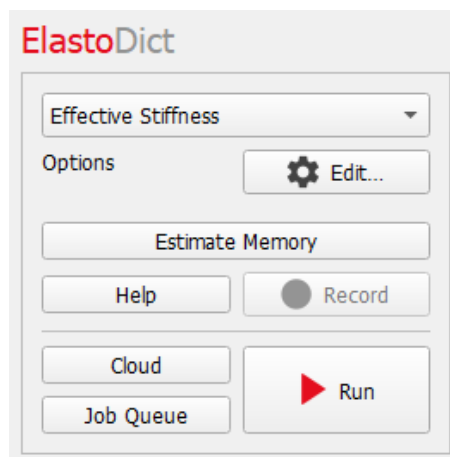

In the **Effective Stiffness Options** dialog which opens after clicking the **Edit...** button, the values under the tabs are adjusted as seen below. For example, under the Constituent Materials tab, the values are adjusted to the mechanical properties values of **Epoxy 3501-6 – Elastic** and **Glass – Elastic-Failure (E-Glass)**.

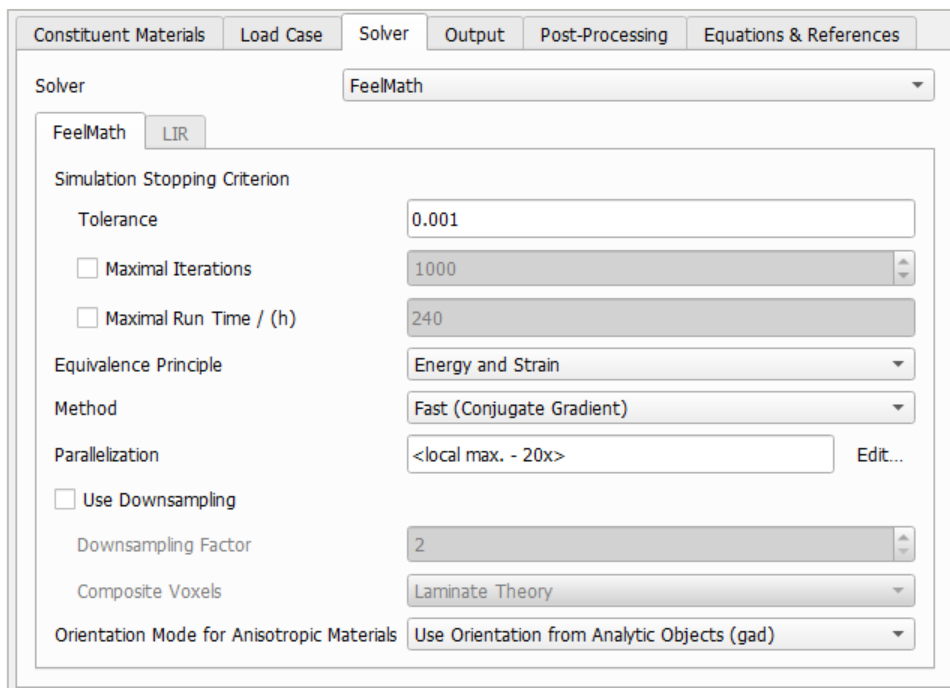
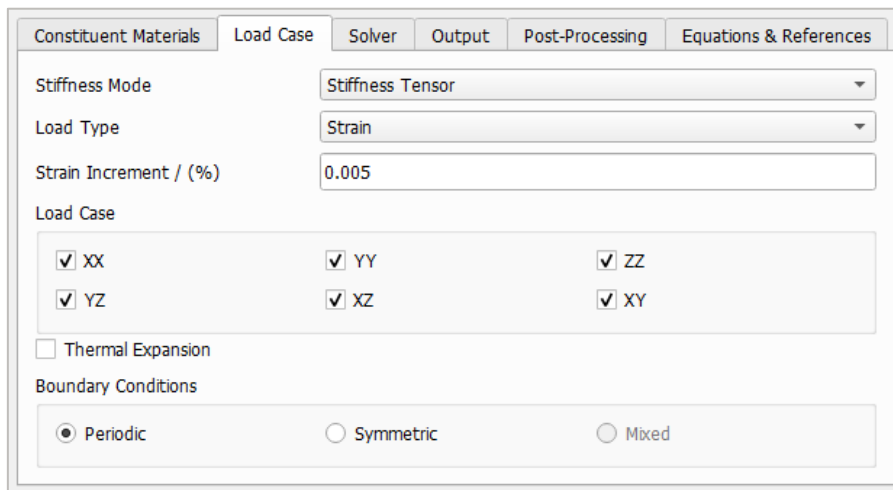
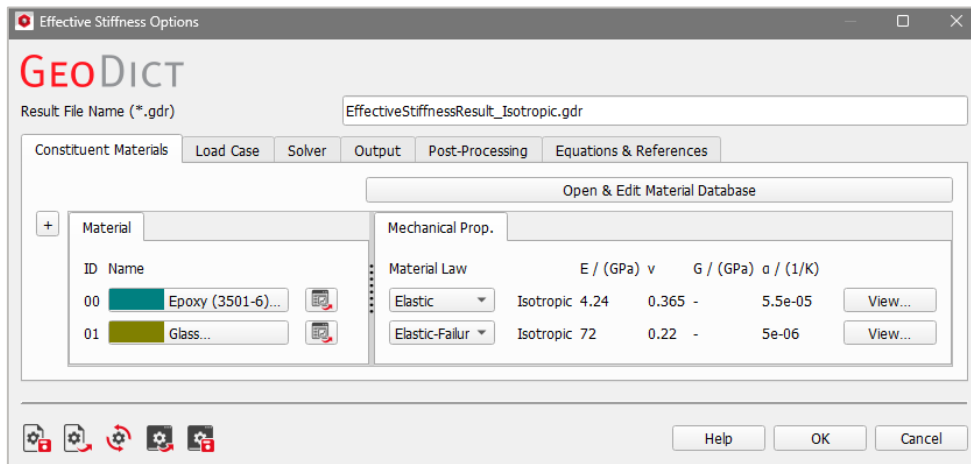

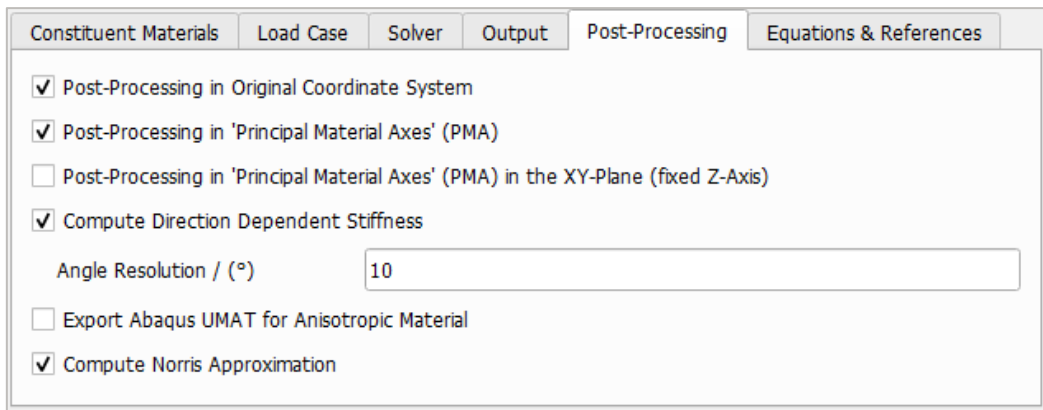
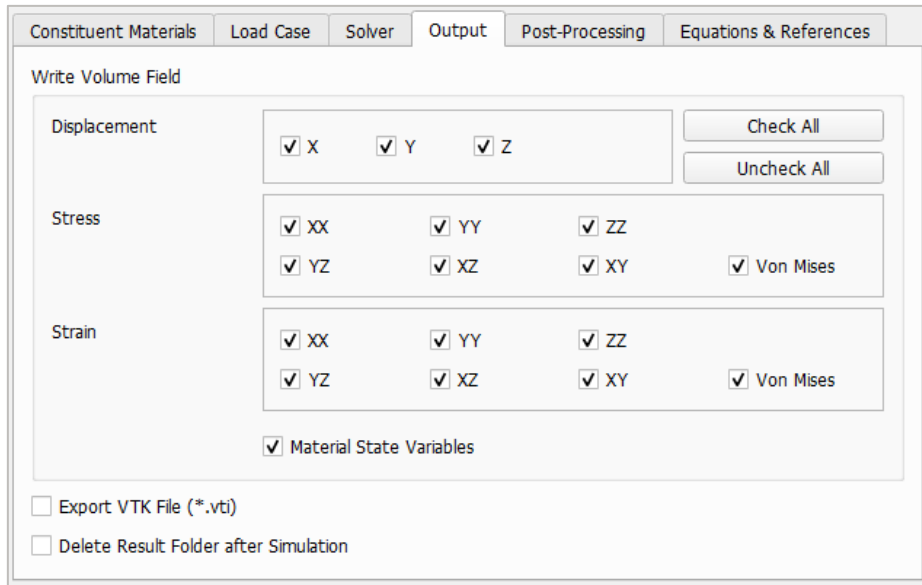

Click **OK** to close the solver options dialog and return to the **ElastoDict** section. After clicking **Run**, the iteration steps made during the calculation can be followed in the console.

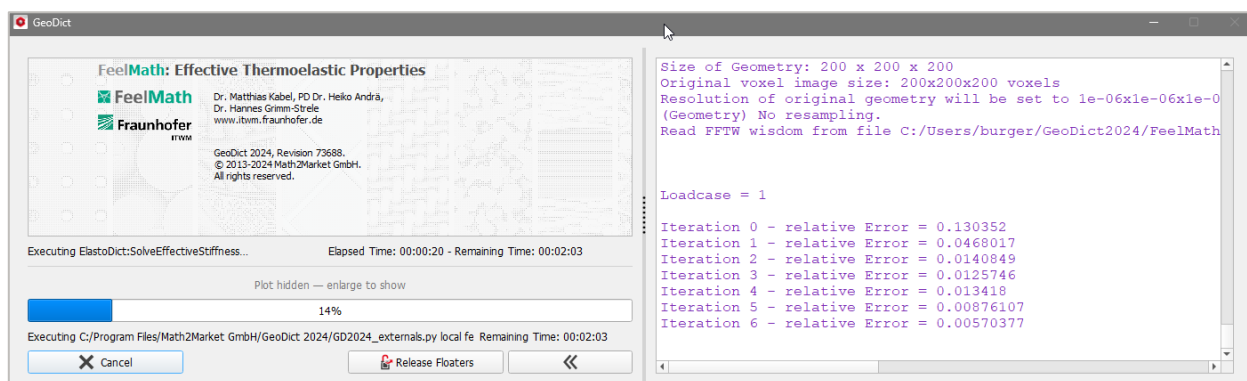

At the end of each of the two computations, the Result Viewer of the result files open.

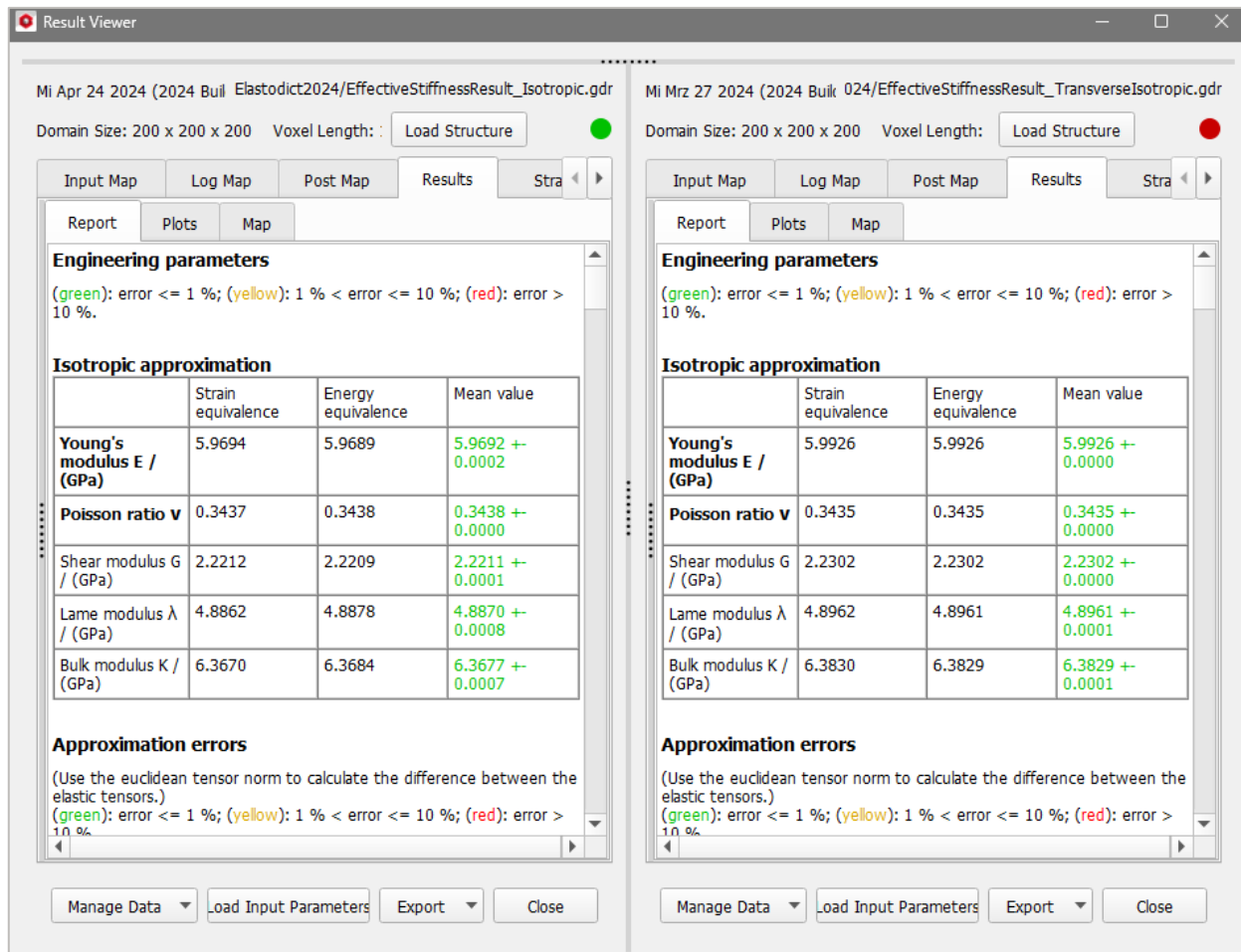

Under the **Results - Report** subtab, several outputs and approximations of the result are provided. These approximations correspond to the different symmetry classes mentioned in page [128](#).

ANISOTROPIC ELASTICITY TENSOR

The **Stiffness Formulation for Strain Equivalence (GPa)** is the first tensor displayed for the **Anisotropic Elasticity tensor**. It is the direct result of the numerical computation and the starting point for all other approximations. This tensor is important if you are not interested in engineering parameters (Lamé parameters) but instead need the most accurate relationship between the stress and the strain. A fully anisotropic material requires 21 distinct parameters to describe it.

For the isotropic and the transversely isotropic composite structures being compared here, this tensor looks as follows:

EffectiveStiffnessResult_Isotropic.gdr					
----- Anisotropic Elasticity Tensor -----					
Stiffness Formulation for Strain Equivalence / (GPa)					
9.2956	4.8686	4.844	-0.019993	0.065157	0.0065814
4.8688	9.4486	4.8987	-0.03641	0.011229	0.0041468
4.844	4.8986	9.3372	-0.060071	0.079522	0.019531
-0.020638	-0.035763	-0.059312	2.2378	0.010911	0.0060656
0.065344	0.010205	0.079742	0.010904	2.1753	-0.032123
0.0070224	0.0046522	0.018717	0.0060734	-0.032113	2.2031

EffectiveStiffnessResult_TransverseIsotropic.gdr					
----- Anisotropic Elasticity Tensor -----					
Stiffness Formulation for Strain Equivalence / (GPa)					
8.4674	4.6584	4.681	0.0043443	-0.0030822	0.016381
4.6588	12.419	4.708	0.074458	0.0054707	0.065615
4.6809	4.7075	8.4649	0.022499	0.0058024	0.005409
0.0041677	0.074371	0.022403	2.1054	0.0063247	-0.01197
-0.0030949	0.005263	0.0057977	0.0062595	1.8993	0.0058182
0.016274	0.06555	0.0052173	-0.011941	0.0058987	2.0447

The values obtained for the coefficients defining the relationship between stress and strain can be compared to the matrix for the general elasticity tensor.

$$C_{\text{general}} = \begin{pmatrix} C_{11} & C_{12} & C_{13} & C_{14} & C_{15} & C_{16} \\ C_{12} & C_{22} & C_{23} & C_{24} & C_{25} & C_{26} \\ C_{13} & C_{23} & C_{33} & C_{34} & C_{35} & C_{36} \\ C_{14} & C_{24} & C_{34} & C_{44} & C_{45} & C_{46} \\ C_{15} & C_{25} & C_{35} & C_{45} & C_{55} & C_{56} \\ C_{16} & C_{26} & C_{36} & C_{46} & C_{56} & C_{66} \end{pmatrix}$$

The other approximations of this general elasticity tensor are shown when scrolling down in the result file. A large difference between the full tensor and an approximation could mean that:

- The representative volume element is too small, and a larger structure should be used for computations.
- The chosen approximation principally does not hold. For example, it could be that assuming that a certain material is isotropic is false.

ISOTROPIC APPROXIMATION FOR STRAIN EQUIVALENCE (GPa)

Isotropy means independence of direction. An isotropic material can be described with two parameters, the Young's modulus E , and the Poisson's ratio ν , which are the same in all directions. In the isotropic case there are only two independent elastic coefficients: E, ν or alternatively, the Lamé parameters λ, μ .

For this approximation, the full 6x6 elasticity tensor is matched against the matrix for the isotropic symmetry class (see the section about Elasticity theory, page 126 ff.). From an isotropic stiffness tensor, the parameters E, ν or λ, μ can be calculated as described below.

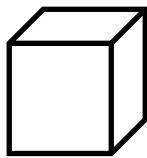

$$C_{\text{isotropic}} = \begin{pmatrix} C_{11} & C_{12} & C_{12} & 0 & 0 & 0 \\ C_{12} & C_{11} & C_{12} & 0 & 0 & 0 \\ C_{12} & C_{12} & C_{11} & 0 & 0 & 0 \\ 0 & 0 & 0 & \frac{C_{11}-C_{12}}{2} & 0 & 0 \\ 0 & 0 & 0 & 0 & \frac{C_{11}-C_{12}}{2} & 0 \\ 0 & 0 & 0 & 0 & 0 & \frac{C_{11}-C_{12}}{2} \end{pmatrix}$$

The Lamé parameters μ (Shear Modulus) and λ (Lamé Modulus) are found by calculating:

$$\mu = \frac{C_{11}-C_{12}}{2} \text{ and } \lambda = C_{12}$$

From the values of μ and λ , the estimates for the effective **Young's modulus** (E) and effective **Poisson's ratio** (ν) are computed as:

$$E = \frac{\mu(2\mu + 3\lambda)}{\mu + \lambda}$$

and

$$\nu = \frac{\lambda}{2(\mu + \lambda)}$$

Other engineering constants can also be obtained by transformation formulas (given e.g., by the [Wikipedia page on Hooke's Law](#)).

For the isotropic and transverse isotropic structures, the Isotropic Approximation for Strain Equivalence look as follows:

EffectiveStiffnessResult_Isotropic.gdr

Isotropic Approximation for Strain Equivalence / (GPa)					
9.3287	4.8863	4.8863	0	0	0
4.8863	9.3287	4.8863	0	0	0
4.8863	4.8863	9.3287	0	0	0
0	0	0	2.2212	0	0
0	0	0	0	2.2212	0
0	0	0	0	0	2.2212

EffectiveStiffnessResult_TransverseIsotropic.gdr

Isotropic Approximation for Strain Equivalence / (GPa)					
9.3565	4.8961	4.8961	0	0	0
4.8961	9.3565	4.8961	0	0	0
4.8961	4.8961	9.3565	0	0	0
0	0	0	2.2302	0	0
0	0	0	0	2.2302	0
0	0	0	0	0	2.2302

Comparing the full anisotropic stiffness matrix with the isotropic approximation, the known structure characteristics are confirmed: the approximated isotropic stiffness values fit well to the corresponding values in the full anisotropic stiffness tensor. But for the transversely isotropic case there is a discrepancy between the approximated isotropic stiffness tensor and the full anisotropic one:

EffectiveStiffnessResult_TransverseIsotropic.gdr

----- Anisotropic Elasticity Tensor -----						----- Isotropic Approximation for Strain Equivalence / (GPa) -----					
Stiffness Formulation for Strain Equivalence / (GPa)						Stiffness Formulation for Strain Equivalence / (GPa)					
8.4674	4.6584	4.681	0.0043443	-0.0030822	0.016381	9.3565	4.8961	4.8961	0	0	0
4.6588	12.419	4.708	0.074458	0.0054707	0.065615	4.8961	9.3565	4.8961	0	0	0
4.6809	4.7075	8.4649	0.022499	0.0058024	0.005409	4.8961	4.8961	9.3565	0	0	0
0.0041677	0.074371	0.022403	2.1054	0.0063247	-0.01197	0	0	0	2.2302	0	0
-0.0030949	0.005263	0.0057977	0.0062595	1.8993	0.0058182	0	0	0	0	2.2302	0
0.016274	0.06555	0.0052173	-0.011941	0.0058987	2.0447	0	0	0	0	0	2.2302

ESTIMATED PRINCIPAL MATERIAL AXES (PMA)

For non-isotropic materials, an appropriate coordinate system is given by the so-called **principal material axes**. While the Cartesian coordinates are the direction of computation (and experiment e.g., taking CT and applying loads), the structure material has its own symmetries e.g., the plane perpendicular to the mean direction of the fibers. These intrinsic symmetries may not be aligned with the Cartesian coordinates yet define another orthonormal coordinate system. The estimation of principal axes is a means to find these intrinsic symmetries.

The principal material axes are fitted as in Rutka, Wiegmann & Andrä who followed Browaeys and Chevrot (See references on page [129](#)). They are shown in the results file and are used for approximations of the elasticity tensors.

EffectiveStiffnessResult_Isotropic.gdr

----- Elasticity Tensor Approx. in the Principal Material Axes (PMA) -----		
Stiffness Formulation for Strain Equivalence		
Estimated Principal Material Axes (PMA)		
0.643979	0.715369	-0.271184
-0.48922	0.657587	0.57292
0.588179	-0.236276	0.773448

(The columns of the table give the PMA in the original coordinate

EffectiveStiffnessResult_TransverseIsotropic.

----- Elasticity Tensor Approx. in the Principal Material Axes (PMA) -----		
Stiffness Formulation for Strain Equivalence		
Estimated Principal Material Axes (PMA)		
0.999241	-0.0220307	-0.0316947
-0.0322447	-0.0244316	-0.999167
0.0218386	0.999459	-0.0256917

(The columns of the table give the PMA in the original coordinate system.)

Here, once again, if the orientation of a structure is not known, the PMAs might give a hint: the PMA of the isotropic structure are more uniformly distributed than the transversely isotropic structure. The letter has one dominant PMA (value) for each coordinate of the original coordinate system (e.g. the first column: 0.99 for the x-axis and -0.03 and 0.02 for y-and z-axis) whereas the discrepancy in magnitude between the values for the isotropic structure are not high (e.g. first column: 0.64, 0.48 and 0.58).

If we denote by U the matrix with the new coordinate vectors:

$$U = \begin{pmatrix} u_1 & v_1 & w_1 \\ u_2 & v_2 & w_2 \\ u_3 & v_3 & w_3 \end{pmatrix}$$

Then, the coordinates of the elasticity tensor c_{ijkl} in the new coordinate system are

$$c'_{\gamma\delta\kappa\lambda} = U_{\alpha\gamma}U_{\beta\delta}U_{j\kappa}U_{l\lambda}c_{\alpha\beta ij}$$

See the section about the elasticity theory, page 126 ff., for the relationship between the elasticity tensor as 4th order tensor and the matrix notation.

ANISOTROPIC ELASTICITY TENSOR IN PMA COORDINATES

The second matrix displayed for the **Stiffness Formulation for Strain Equivalence** shows the Anisotropic Elasticity Tensor (GPa) in PMA Coordinates. In particular, the difference from this tensor can be used to estimate the quality of the Orthotropic Approximation, Transverse Isotropic Approximation, Cubic Approximation (all in PMA coordinates), and Isotropic Approximation shown also in the result file.

The Anisotropic Elasticity Tensor in PMA Coordinates looks similar to the **Anisotropic Elasticity Tensor**, but it has been transformed to another coordinate system. The off-diagonal coefficients are smaller, so that setting them to zero would lead to smaller errors. For our examples, we obtain:

EffectiveStiffnessResult_Isotropic.gdr					
Anisotropic elasticity tensor / (GPa) in PMA coordinates					
9.4305	4.9201	4.896	0.006482	0.024809	-0.02704
4.9207	9.3351	4.8598	0.03097	-0.0034967	-0.043703
4.8964	4.8602	9.1847	0.086395	0.026885	-0.020382
0.0071682	0.030598	0.086158	2.1869	-0.03095	-0.008255
0.024266	-0.0026872	0.026357	-0.031149	2.2342	-4.4413e-05
-0.02761	-0.044045	-0.019464	-0.008244	-0.000	
EffectiveStiffnessResult_TransverseIsotropic.					
Anisotropic elasticity tensor / (GPa) in PMA coordinates					
8.4653	4.6854	4.6609	-0.0076955	-0.0050422	0.00053743
4.6853	8.4634	4.7068	-0.016538	-0.0049699	0.0087232
4.6623	4.7084	12.42	0.0080475	0.096185	0.0089426
-0.0083938	-0.015954	0.0076718	2.1052	-0.0093605	0.0020286
-0.0044457	-0.0055395	0.095757	-0.0093506	2.0467	-0.0034061
0.0016056	0.0097076	0.0083506	0.0021161	-0.0032948	1.8998

Technical
documentation:

Lilli Burger
Sebastian Rief
Aaron Widera
Barbara Planas

MATH
2 MARKET

Math2Market GmbH

Richard-Wagner-Str. 1, 67655 Kaiserslautern, Germany
www.geodict.com