

FIBERFIND

User Guide

GeoDict release 2024

Published: July 2, 2024

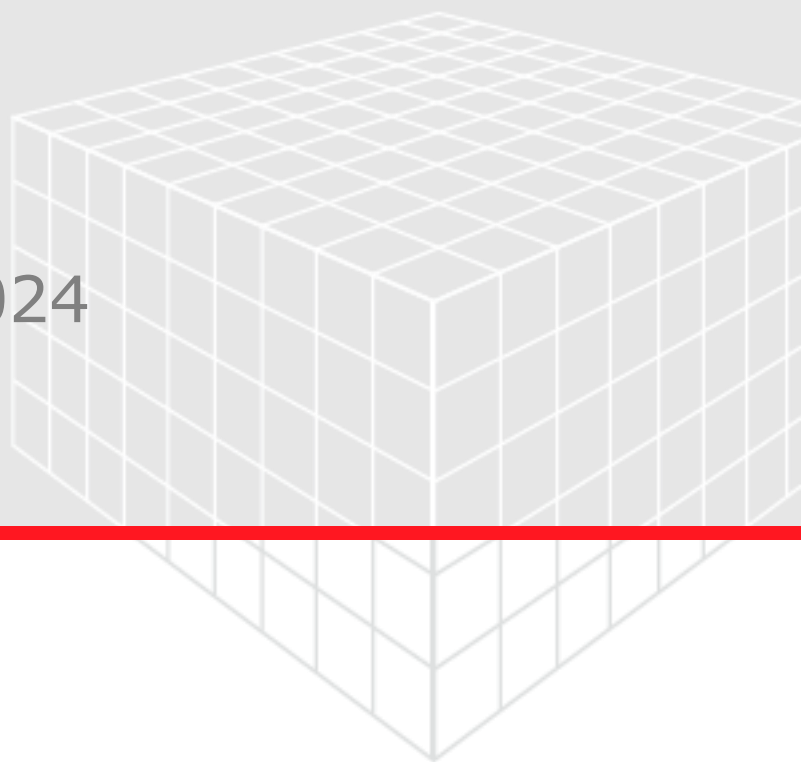

GEO DICT

<https://doi.org/10.30423/userguide.geodict>

© Math2Market GmbH 2024

Citation:

Anja Streit, Rolf Westerteiger, Lilli Burger, Barbara Planas. GeoDict 2024 User Guide. FiberFind handbook. Math2Market GmbH, Germany, doi.org/10.30423/userguide.geodict

All rights reserved. It is not permitted to reproduce the book or parts thereof in any form by photocopy, microfilm or other methods or to transfer it into a language suitable for machines, in particular data processing systems, without the express permission of the publisher. The same applies to the right of public reproduction.

The handbooks in the User Guide series of Math2Market GmbH can be obtained from:

Math2Market GmbH
Richard-Wagner-Strasse 1
67655 Kaiserslautern
Germany

Phone: +49 631 205 605 0
Fax: +49 631 205 605 99
Email: info@math2market.de
Web: www.math2market.de

IDENTIFICATION OF BINDER AND FIBERS AND ANALYSIS OF FIBER PROPERTIES IN FIBROUS MEDIA 1

INTRODUCTION	1
FIBERFIND AI MODULES	1
Using the GPU version	2
TUTORIALS	2
THEORY – APPROACHES FOR FIBER IDENTIFICATION	3
AI APPROACH TO IDENTIFY BINDER AND FIBERS	3
Current constraints of FiberFind-AI for fiber and binder identification	4
IMAGE PROCESSING APPROACH TO IDENTIFY SEPARATE FIBERS	5
ANALYSIS OF FIBER DIAMETER, ORIENTATION, CURVATURE, CURLINESS, AND TORSION	5
Computation of fiber diameters	5
Computation of fiber orientations	6
Computation of curvature and curliness	7
Computation of Torsion	8
FIBERFIND SECTION	9
ESTIMATE FIBER DIAMETERS	10
Estimate fiber diameters result file	12
ESTIMATE FIBER ORIENTATIONS	17
Estimate fiber orientation results	20
Estimating fiber orientation in layered materials	24
ESTIMATE FIBER CURVATURE	26
REPRODUCING FIBROUS MEDIA USING FIBERFIND AND FIBERGEO	28
Homogeneous Fibrous Media	29
Heterogeneous (layered) fibrous media	32
Reproducing curvature of fibrous media	38
IDENTIFY FIBERS (AI)	39
Fiber identification	40
Solver Options	43
Output Options	44
Equations & References	45
Fiber identification results	46
IDENTIFY BINDER (AI)	61
Binder identification results	65
Binder identification validation	68
Measure the quality of the algorithm	71

IDENTIFICATION OF BINDER AND FIBERS AND ANALYSIS OF FIBER PROPERTIES IN FIBROUS MEDIA

INTRODUCTION

The **FiberFind** module covers the functionalities in **GeoDict** that aim to understand 3D scans of fibrous materials, like nonwovens and fiber-based composites, e. g. glass fiber reinforced or carbon fiber reinforced composites. **FiberFind** requires as input 3D models that are previously obtained from segmented micro CT scans or FIB/SEM scans of the material.

Three distinct approaches are pursued in **FiberFind**:

1. Estimate statistical properties of fibers: diameter distribution, orientation distribution, curviness, and curliness
2. Identify individual fibers by classical image processing methods
3. Identify individual fibers and binder by Artificial Intelligence (AI) approaches

In **FiberFind**, we assume that pores have already been separated from solids, and that the solids consist of individual fibers and possibly some binder. Binder and fibers usually have the same gray values in the images. An automatic separation based on the gray value is therefore not possible. **FiberFind** with the submodule **Identify Binder (AI)** provides the possibility of separating binder from fibers automatically prior to the identification of separate fibers.

FiberFind analyzes the diameter, orientation, and curvature of fibers, to estimate the performance of fibrous structures.

FiberFind is the starting point to reproduce fibrous structures with **FiberGeo**. The user can input the statistical parameters obtained with **FiberFind** in **FiberGeo** and model isotropic and anisotropic materials. Subsequently, the statistical parameters of the modelled structure may be easily varied to investigate the effect of material structure on the performance of materials. By being used together, **FiberFind** and **FiberGeo** are intended to close the digital fibrous material design loop.

FiberFind is particularly well suited for the analysis in fibrous structures made of non-hollow fibers with circular cross-section.

FIBERFIND AI MODULES

The AI modules of **FiberFind** – **Identify Fibers (AI)** and **Identify Binder (AI)** - are only available in the **GeoDict** GUI if a corresponding license (**FiberFind-AI**) is available. Otherwise, only the analytic modules of **FiberFind** can be used.

FiberFind - Identify Fibers (AI) and **Identify Binder (AI)** uses PyTorch, one of the most used and well-known machine learning libraries. The required version of PyTorch will be installed during **GeoDict** installation and **FiberFind** will work out of the box. Install **GeoDict** with administrator rights on your machine to install PyTorch correctly.

FiberFind can run on the CPU (the main processor) or on the GPU (the graphics card). If a suitable GPU is detected, **FiberFind- Identify Fibers (AI)** and **Identify Binder**

(AI) will run on the GPU, otherwise on the CPU. An example of how to choose the **Batch Size** is given on page [43](#).

Since **FiberFind** ships with a limited number of neural networks for fiber and binder identification, currently some constraints on the input data exist that are listed under [Current constraints](#).

USING THE GPU VERSION

The **GPU version** is usually **much faster** (roughly factor 10) than the CPU version, but it requires:

- An NVIDIA graphics card (GPU) with compute capability of at least 3.5.

Please make sure your drivers are installed and up to date. For the version of CUDA required by **GeoDict**, you need at least version 450.80.02 of the NVidia driver for Linux or version 452.39 for Windows.

See more information on graphics cards in <https://developer.nvidia.com/cuda-gpus>. This webpage contains a helpful section with Frequently Asked Questions.

TUTORIALS

Besides this handbook of the User Guide, several tutorials showing the possibilities of the AI based **FiberFind** approach for different application cases are available on the [GeoDict website](#).

One tutorial is dealing with the analysis of four samples of different carbon paper gas diffusion layers used for a proton-exchange membrane in a fuel cell (*Digital analysis of fibers and binder content of a carbon paper GDL*). Synchrotron scan data for the sample is provided with the tutorial. The tutorial contains a detailed description of the import and preprocessing of the data, the binder and fiber identification using the AI approach, and postprocessing options for the results.

A second tutorial deals with the **FiberFind** identification of fibers of a composite material, a glass-fiber reinforced polymer, as well as the mechanical analysis of the digital 3D model with **ElastoDict** (Digital analysis of a GFRP and generation of statistical Digital Twin). Input data and detailed description about preprocessing of the data is provided with the tutorial.

THEORY – APPROACHES FOR FIBER IDENTIFICATION

The following section explains the algorithms used by **FiberFind**. First, we explain the identification of binder and fibers with the AI approach, and the identification of fibers using the classical image processing approach.

Then follows a short explanation of the estimation of statistical fiber properties, diameter distribution, orientation distribution, curviness, curliness and torsion.

AI APPROACH TO IDENTIFY BINDER AND FIBERS

The **FiberFind** module provides the possibility of using Artificial Intelligence (AI) approaches for the separation of binder and fibers as well as the identification of individual fibers in a fibrous structure.

In the image taken from a material, fibers and binder often have the same gray values, and therefore cannot be separated based on this value. The same holds true for the separation of different fibers. However, it is possible to separate binder from fibers and fibers from each other based on the shape in the image.

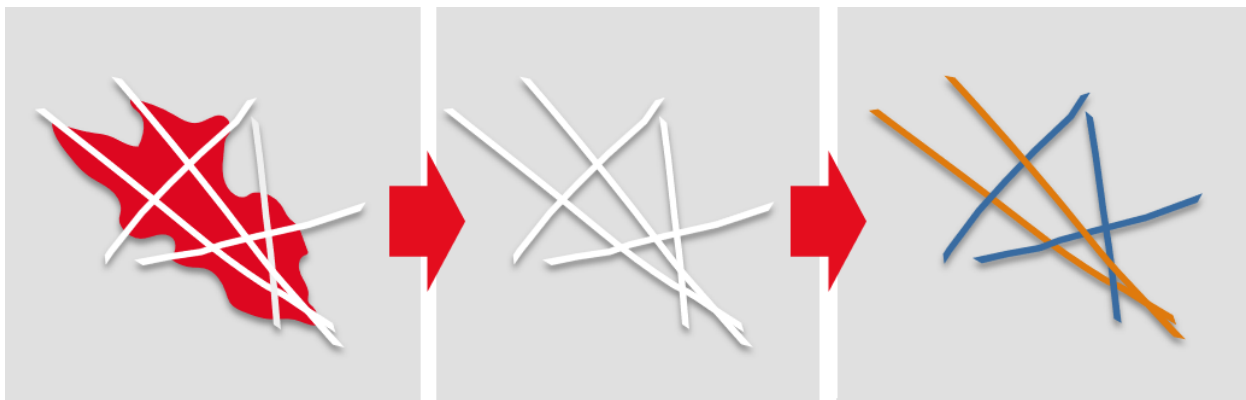

The **fundamental idea of AI** is that a neural network is trained to perform a special task, here the identification of separate fibers or the differentiation between fibers and binder. To train the neural network, enough examples need to be available to teach it. Clearly, for 3D-scans it is a very hard and time-consuming task to manually label materials or objects for the number of examples required, which are typically hundreds of millions. This is where **GeoDict's unique structure-generation capabilities** come in.

The **FiberGeo** module can create innumerable models of fibrous media and can also add binder to these models. Variations of fiber diameters, fiber shape, fiber length, fiber curvature, fiber density, etc. and also the amount and location of binder can be carried out as needed.

As long as the models are close enough to the real 3D-scans, **GeoDict** is capable of providing the needed ground truth data for the neural networks that embody the AI capability in **FiberFind**. Since **GeoDict 2021**, the capability to create and parameterize these neural networks is available in the module **GeoDict-AI**. For more details see the [GeoDict-AI](#) handbook of the [User Guide](#).

Based on the trained neural network, **FiberFind** decides for each voxel of the structure whether it is binder or fiber and sets the material ID accordingly.

In the same way, a trained neural network for **FiberFind-Identify Fibers (AI)** decides for each voxel to which fiber it belongs.

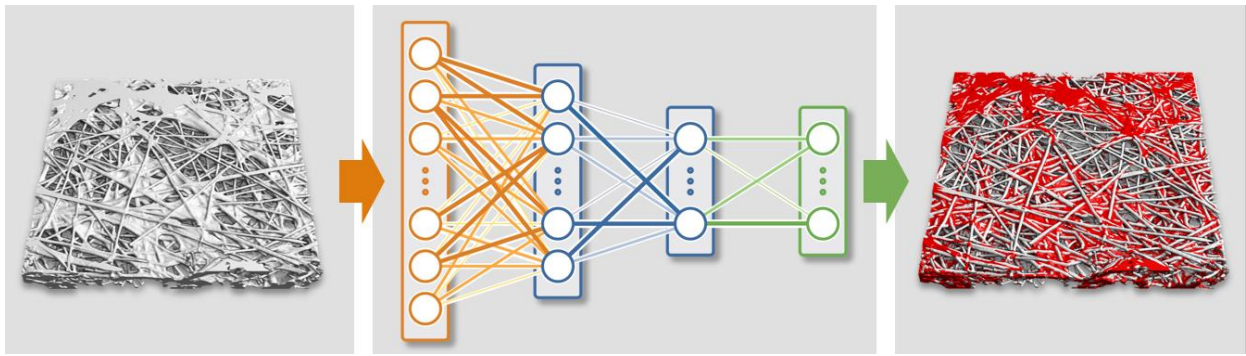

The current version of **FiberFind-Identify Fibers (AI)** and **FiberFind-Identify Binder (AI)** come with a single neural network each that can be applied to segment data sets in the **FiberFind** module. Therefore, currently some constraints on the input data exist which may make it necessary to preprocess the input data before applying the AI approach.

CURRENT CONSTRAINTS OF FIBERFIND-AI FOR FIBER AND BINDER IDENTIFICATION

- Fiber diameters should be 4 to 10 voxels for binder identification and 4 to 40 voxels for fiber identification.

If fiber diameters differ from this value, **ImportGeo-Vol** can be used to resample the voxel length. During the import of an image, the 3D Image Processing functionality **Image Size**→**Scale** can be used for scaling the 3D image with a different voxel length. Details can be found in the [ImportGeo-Vol](#) handbook, in the section **3D Image Processing in ImportGeo-Vol** → **Image Processing Tools** → **Image Size** → **Scale**.

- If fiber diameters in the structure are very different, and therefore, after resampling, not all diameters lie in the range listed above, we suggest separating the fibers and applying **FiberFind - Identify Fibers (AI)** for each kind of fiber.

To separate the fibers, **Estimate Fiber Diameters** in **FiberFind** can be used. Run the fiber diameter estimation and choose the number of fiber types in the Result Plots to fit to your structure. On the tab **Result Visualization**, you can then load a .gdt file with the fibers separated according to different fiber types. See [Estimate fiber diameters](#) below for detailed instructions and an example.

- Some networks require fibers to be oriented mainly in the x-y plane. Please see the individual network description in the dialog. If necessary, the structure can be rotated to fulfill this condition.

Changing the coordinate axis is done easily through **ProcessGeo** → **Permute** functionality. Details can be found in the [ProcessGeo](#) handbook.

Changing the coordinate axis or applying complex rotations to the structure by defining Euler angles is also possible through **ImportGeo-Vol**. Details are explained in the [ImportGeo-Vol](#) handbook in **3D Image Processing in ImportGeo-Vol** → **Image Processing Tools** → **Image Alignment** → **Rotation**.

- Fiber identification works for circular and elliptical fibers right now, not for other cross sections such as hollow or trilobal fibers.

IMAGE PROCESSING APPROACH TO IDENTIFY SEPARATE FIBERS

For the identification of separate fibers using the image processing approach, **FiberFind** identifies fibers using a skeletonization algorithm which thins out the fiber structure until the fibers are reduced to a skeleton which represents the center lines of the individual fibers.

The identification of fibers with classical image processing methods is optimized for low density fibrous materials.

ANALYSIS OF FIBER DIAMETER, ORIENTATION, CURVATURE, CURLINESS, AND TORSION

The computation of the fiber diameter, fiber orientation, fiber curvature, and fiber curliness are explained directly below.

If analytic object data (GAD) is available, the properties are computed directly based on these objects. This is usually only true for structures generated with **GeoDict**. Otherwise, if only a voxel image is available, the fibers are identified first using image processing before running the analysis.

COMPUTATION OF FIBER DIAMETERS

The algorithm to estimate fiber diameters works as follows: At the start, each fiber voxel gets assigned the value of the largest sphere fitting into the fiber in this position. Then, it is checked for each fiber voxel if it lays inside of a larger sphere compared to the diameter of the sphere already assigned to the voxel under consideration.

For this comparison, there are two possibilities:

- The center of the smaller sphere is contained within the larger sphere. Then, the diameter value of the larger sphere is assigned to all voxels in the smaller sphere. Voxels at the end of a fiber get like this the same diameter as neighboring parts of the fibers and not a smaller one. See the following figure.

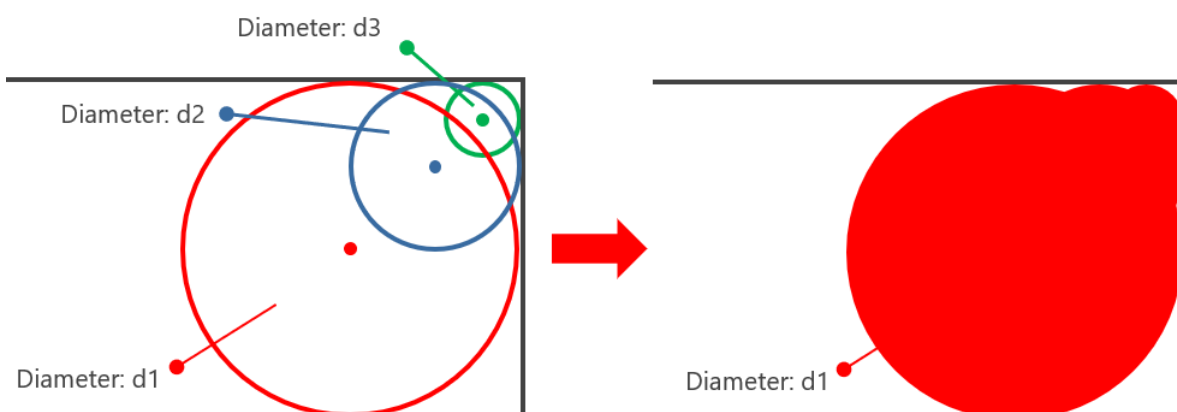

- The center of the smaller sphere is not contained within the larger sphere. Then, the overlapping area between both spheres is partitioned between both diameters. Like this, fibers overlapping each other both get the correct diameter. See the following figure.

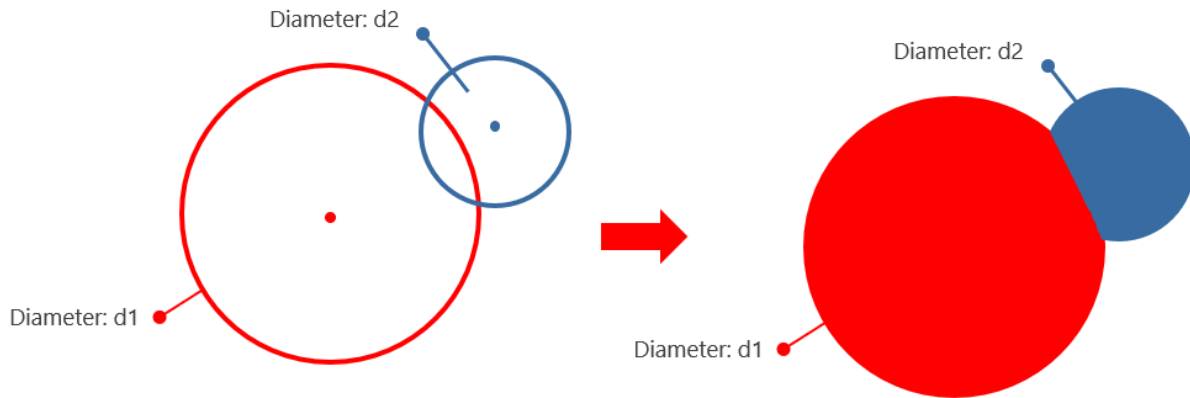

COMPUTATION OF FIBER ORIENTATIONS

To compute fiber orientations, two algorithms are used:

- Star Length Distribution (SLD):
 1. Analysis is done on a per-voxel basis.
 2. For each voxel, it analyzes chord lengths through the voxel for a pre-defined set of directions.
- Principal Component Analysis (PCA):
 1. The domain is cut into blocks of a fixed size (currently 32x32x32).
 2. For each block, all connected components are found. Ideally, they correspond to segments of individual fibers.
 3. For each component, it is assumed that the voxels of the component form a point cloud. An ellipsoid which best approximates this point cloud is computed using the PCA method (Principal Component Analysis) and provides the principal orientation.
 4. The principal orientation vectors are averaged to get a per-block orientation.
 5. Per-block orientations are averaged to obtain the desired number of orientation tensors.

In summary, the PCA method cuts the fibers into segments and determines the local average of the orientation of these segments to obtain an orientation tensor.

For both algorithms, GOF files (GeoDict Orientation Files) can be saved to allow for simulation of anisotropic properties (e.g. transverse isotropic) of fibrous structures. In case of transverse isotropy, the material properties in fiber direction differ from properties in the perpendicular direction.

These GOF files can be used e.g. in [ElastoDict](#) for computations of mechanical properties in anisotropic materials.

COMPUTATION OF CURVATURE AND CURLINESS

FiberFind can calculate curliness and curvature distributions in models of fibrous structures. Curved fibers occur in materials for numerous industrial sectors: synthetic filter media, cellulose filter media, gas diffusion layers (GDL) in fuel cells, insulation materials, nonwovens for many applications, etc.

The calculated curvature is based on the definition of geometric curvature. At any point on the curve, the curvature is defined as the inverse radius of the osculating circle. The osculating circle has the same tangent vector as the curve at that point and approximates the curve locally.

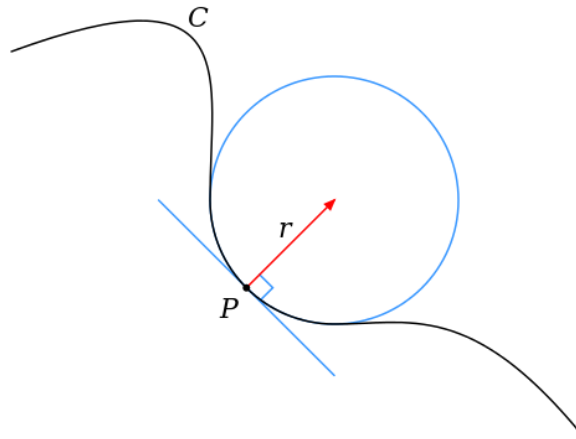

The curl-index measured by **FiberFind** is the length of the fiber divided by the distance between its start and its end. For straight fibers, this results in a curl-index of 1.



FiberFind calculates the curvature and curliness based on the centerline and the length of fibers. If no analytic data (.gad) is available, e.g., from a previously run fiber identification, **FiberFind** identifies the fibers with the classical image processing approach first.

The curvature estimation component is intended to be used with highly porous fibrous media (>90%). Solid volume fractions above 10% can decrease the accuracy of the result.

Since **GeoDict 2023**, additionally the autocorrelation of the curvature is computed for the fibers identified. This is done by interpolating first the curvature over each fiber and computing the autocorrelation from the interpolated values. The mean of these autocorrelation is then computed over all fibers. The autocorrelation function is cut at the fiber length that is exceeded by only 20% of the fibers.

COMPUTATION OF TORSION

Since **GeoDict** 2023, the computation of the torsion of the cross-section area is available for the fibers identified. The torsion is computed for each fiber segment and as mean value for each whole fiber.

Like for the curvature, the autocorrelation of the torsion is computed as well. The torsion is first interpolated over the length of each fiber, and the autocorrelation is computed for each fiber separately. Then, the mean of this autocorrelation is computed over all fibers. At a fiber length that is exceeded by only 20% of the fibers, this autocorrelation function is cut.

The result of the torsion computation is available so far only in the **GeoDict** result file, see page [50](#).

FIBERFIND SECTION

FiberFind starts when selecting **Analyze** → **FiberFind** in the menu bar.



Five processes are listed and can be selected from the pull-down menu in the **FiberFind** section: **Estimate Fiber Diameters**, **Estimate Fiber Orientations**, **Estimate Fiber Curvature**, **Identify Fibers (AI)** and **Identify Binder (AI)**.

The options for each process can be edited after selecting it from the pull-down menu and clicking the **Options' Edit...** button.

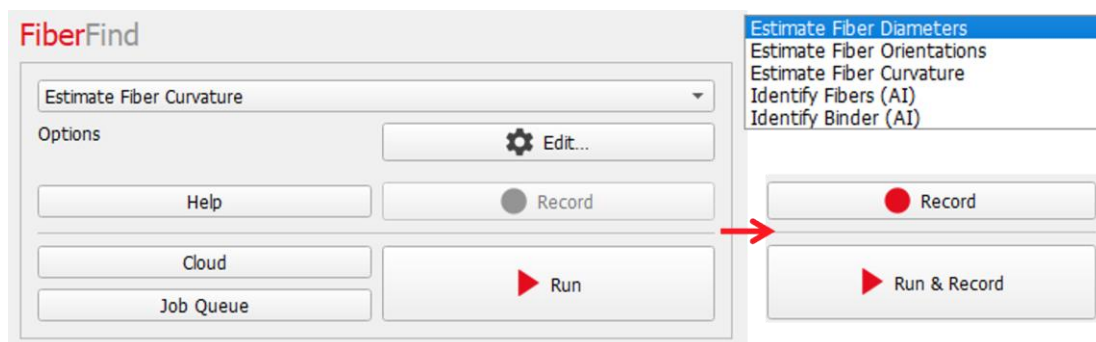

When the options for the selected **FiberFind** process have been entered, clicking **Run** starts the computation.

When recording a macro, e.g. to run parameter studies, the **Record** button becomes active and the **Run** button changes to **Run & Record**.

The results from all **FiberFind** computations are saved as ***.gdr** files in the project folder. **GeoDict** result files (*.gdr files) can be opened with the **GeoDict** Result Viewer by selecting **File** → **Open Results (*.gdr)** from the menu bar.

For the analysis with **FiberFind**, a segmented image of the material needs to be available. **ImportGeo-Vol** can be used to import data of (μ)CT (or FIB/SEM) scans, to get a segmented three-dimensional model (see the [ImportGeo-Vol](#) handbook).

The button **Cloud** allows to perform the calculations in the **GeoDict** Cloud and with **Job Queue** the simulation run can be executed on a job queue server. More information on how to start a calculation in the cloud or the job queue can be found in the [High Performance Computing](#) handbook of the **GeoDict** User Guide.

If interested in cloud simulations contact Math2Market to apply for a **GeoDict** cloud license.

ESTIMATE FIBER DIAMETERS

Start with a 3D-model of a fibrous material that has been loaded in memory and is displayed in the Visualization area.

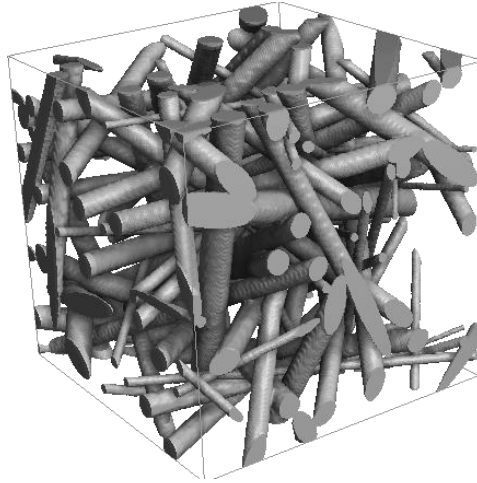

In the **FiberFind** section, select **Estimate Fiber Diameters** from the pull-down menu and click the **Options** → **Edit...** button.

In the opening **Fiber Diameter Estimation** dialog, enter the desired **Result File Name (.gdr)** or keep the default **FiberDiameters.gdr**.

From the **Material to Analyze** pull-down menu, select to analyze **All Solid Materials** in the 3D-model (analyze all solid and porous materials), only a **Chosen Material**, or materials of the **Chosen Material IDs**.

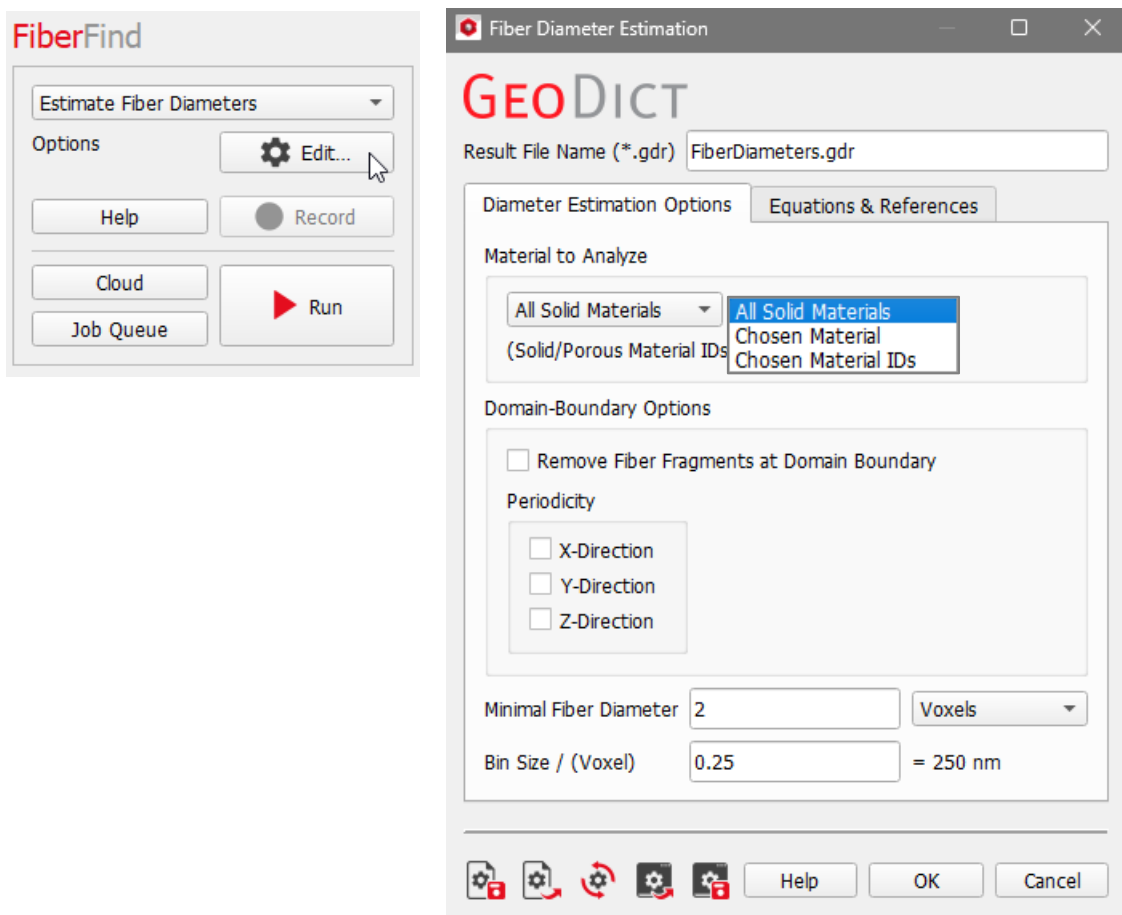

When **Chosen Material** is selected, it is possible to analyze any material included in the model.

When **Chosen Material IDs** is selected, the user can choose to analyze any of the 256 Material IDs that could appear in a model. This can be used when a material appears through overlapping of fibers, or to exclude binder from the fiber diameter analysis.

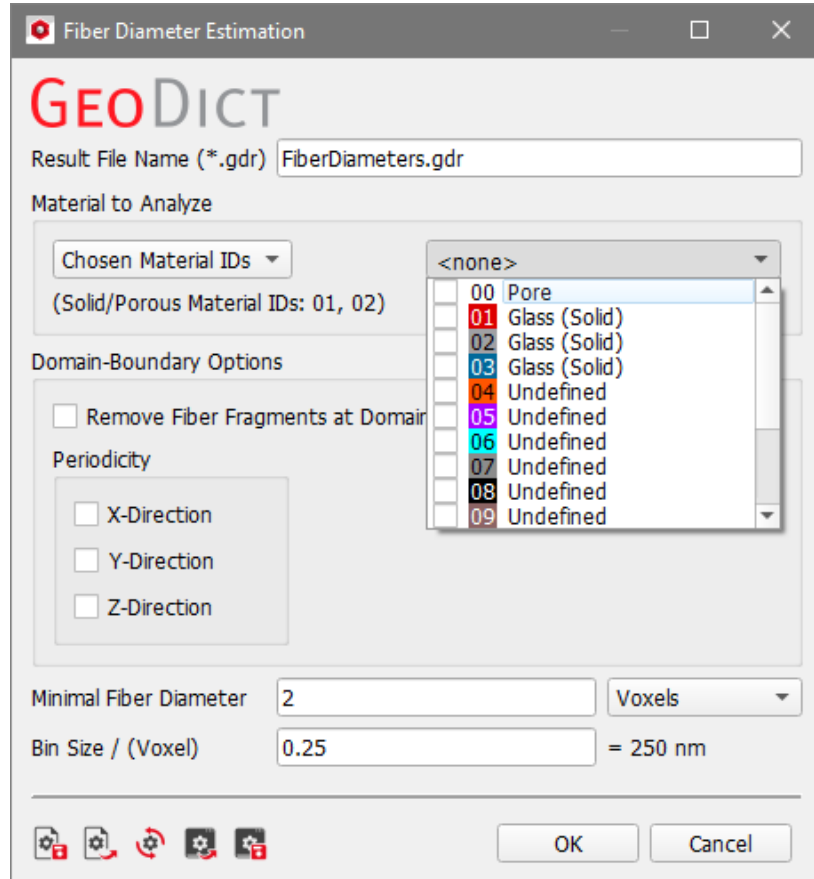

Check **Remove Fiber Fragments at Domain Boundary** to remove fragments of fibers that touch the domain boundary after running the fiber identification algorithm. Fibers which are cut at the domain boundary might distort the resulting statistics towards shorter lengths if this option is not selected. The diameter statistics might also be affected.

If the material is periodic in one or several directions, this can be accounted for by checking the boxes for **Periodicity**. For example, for periodicity in x-direction, fibers leaving the domain on one end in x-direction will be considered to relate to a fiber starting at the other end of the domain with similar y and z values. This is usually only true for periodically generated **FiberGeo** structures or e.g. for weave structures. Most scans of real material will not exhibit periodicity.

If any information is available about the minimal fiber diameter, this information can be entered in **Minimal Fiber Diameter**. This speeds-up the computation, as the algorithm starts with this minimal diameter and not with zero for the diameter estimation. However, since fiber segments with diameter smaller than the value given are ignored if they are not connected to a larger fiber, the recommendation is to enter a fiber diameter slightly smaller than the one known, to make sure that all fiber segments are considered. The minimal diameter can be given in meter or as number of voxels.

Identification of binder and fibers, and analysis of fiber properties

The **Bin Size** (in Voxels) defines the resolution of the diameter analysis for the result visualization as histogram and for the computation of diameter distribution for one or several types of fibers. It can also be changed after the run from within the **GeoDict** Result Viewer.

A result file with the given Result File Name is saved in the chosen project folder (**File** → **Choose Project Folder...**) after the analysis, and a Result Viewer opens, showing the calculated values.

ESTIMATE FIBER DIAMETERS RESULT FILE

If the fiber diameter estimation ran successfully, a **GeoDict** Result Viewer opens. The header section can be collapsed and expanded. In the Result Viewer, the results are organized into **Input Map**, **Log Map**, **Post Map**, **Results**, **Data Visualization** and **Metadata**, which are accessed through the corresponding tabs.

Under the **Results - Report** sub-tab, the average diameter and the corresponding standard deviation for all fibers, as well as averages, standard deviations and medians of the binned histogram values for each fiber type are displayed. An example of two different fiber types is shown below. The histogram is also shown in tabular form, giving the minimum and maximum diameter of each bin, as well as the volume fraction of fibers with this diameter range.

The screenshot shows the **Result Viewer** window with the **Results** tab selected. The **Report** sub-tab is active, displaying a **FiberFind** report. The report includes a general analysis of the size distribution, a fiber type analysis table, characteristic diameters, and a histogram table.

Type	Average inner diameter / (μm)	Standard deviation / (μm)	Median diameter / (μm)	Volume fraction / (%)
Type 1	7.68574	2.44857	9.375	15.9505
Type 2	13.063	1.87531	12.375	84.0495

Min. diameter / (μm)	Max. diameter / (μm)	Volume fraction / (%)
0	0.25	0
0.25	0.5	0
0.5	0.75	0
0.75	1	0

In the post-processing section, left of the Results tab, the **Bin Size** (in Voxels), the **Thresholding Method**, and the **Number of Fiber Types** can be changed. These post-processing commands allow control on the display of the result data. The post-processing section can also be collapsed and expanded.

Changing the **Bin Size** changes the width of the histogram bin and, therefore, its resolution.

The **Thresholding Method** for the separation between fibers of different fiber types allows to choose between the **K-Means**, **Otsu's** method and a **Manual** selection of the threshold. This option is only relevant for two or more different fiber types.

If the analyzed structure contains fibers of different types, specify the **Number of Fiber Types**, and for each type, a Gaussian is fitted to the data.

Click **Apply** to apply the changes to all presented results, like the distribution values shown in the **Report** subtab and the histogram plots on the **Plots** subtab.

If **Back-up result file** is checked, a back-up file describing the previous results is stored in a directory named as your result file in your project folder (e.g. FiberDiameters.gdr.bck1).

The histogram shown under the **Results - Plots** subtab shows the volume fraction of the fibers for each fiber diameter, together with a Gaussian fit to the histogram data. In the example shown below the highest volume fractions for one fiber type correspond to fibers with diameters around 12 μm .

However, in the example shown here, the structure consists of two fiber types: fibers with small diameter between 2-8 μm , and fibers with diameter between 9-18 μm .

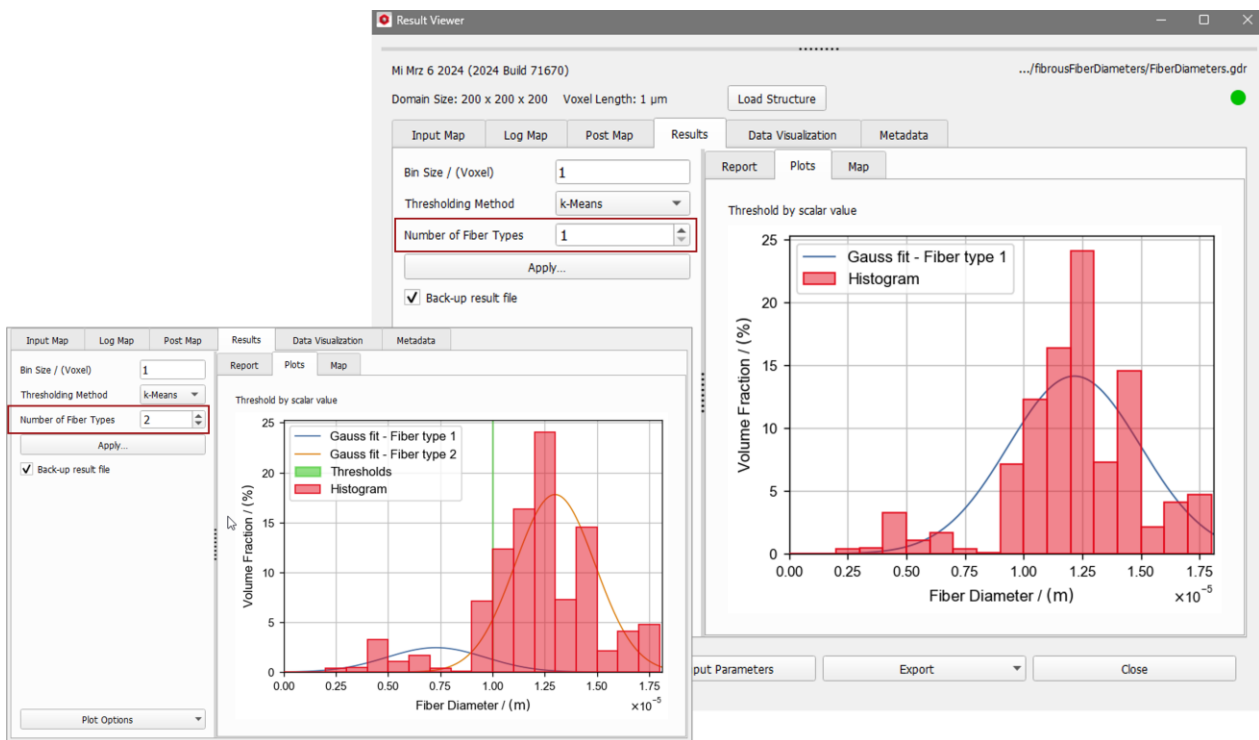

Choosing two different fiber types instead of one type, leads to Gaussian distributions that fit much better to the fiber diameters present in the structure. The structure with a separation of the two different types of fibers is shown on page 14.

Under the **Data Visualization** tab, the **Fiber Type Structure** and the **Fiber Diameter Distribution** can be loaded.

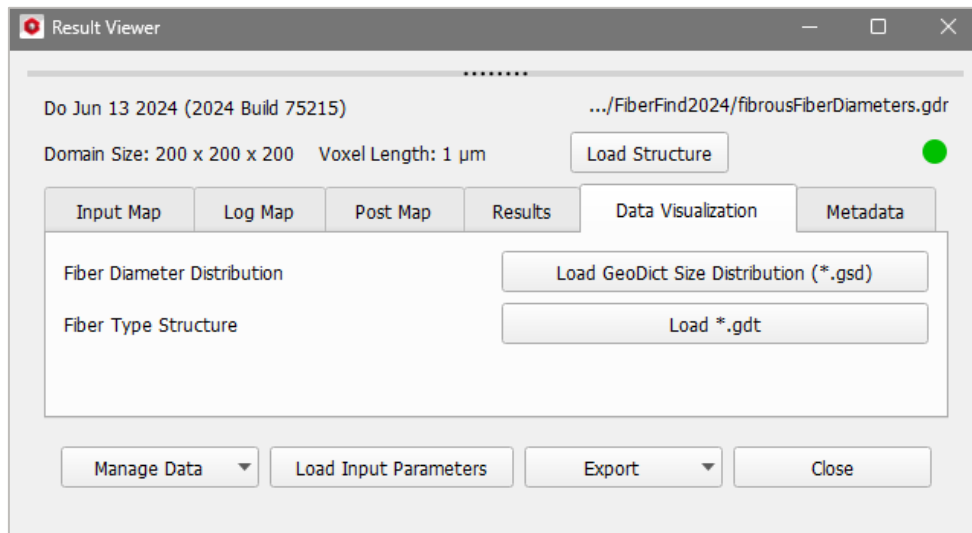

Clicking **Load *.gdt** opens a **GeoDict** structure. All fibers assigned to one fiber type have the same Material ID in this structure. In case of two different fiber types, as shown in the example here, fibers with small diameter have the Material ID 01 (here in yellow). Fibers with large diameter have Material ID 02 (here shown in grey) and are assigned to Fiber Type 2. The corresponding histogram of fiber diameters is shown on page [13](#).

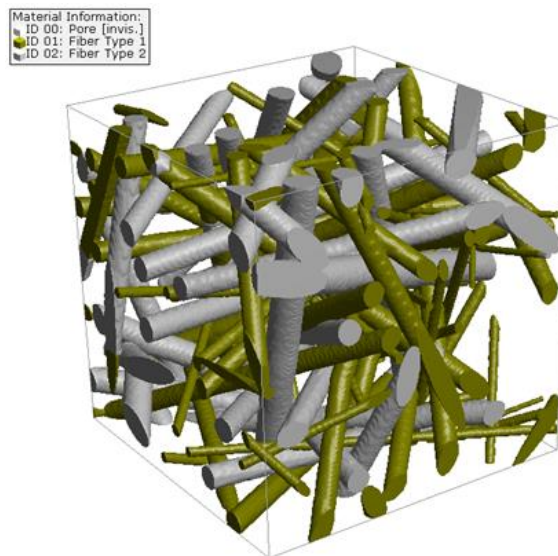

If postprocessing parameters in the **Results** tab (Bin Size, Thresholding Method, or Number of Fiber Types) are changed, the information in the .gdr file also changes.

This information can be used for the separation of fibers with different fiber diameters. Reassign e.g. all voxels with Material ID 01 to ID 00 with **ProcessGeo**. In this way, only solid voxels with Material ID 02 remain in the structure and can be analyzed separately.

Now, click the **Load GeoDict Size Distribution (*.gsd)** button to observe the computed fiber diameter distribution. Check **Diameter** as the volume field to be loaded and click **OK**.

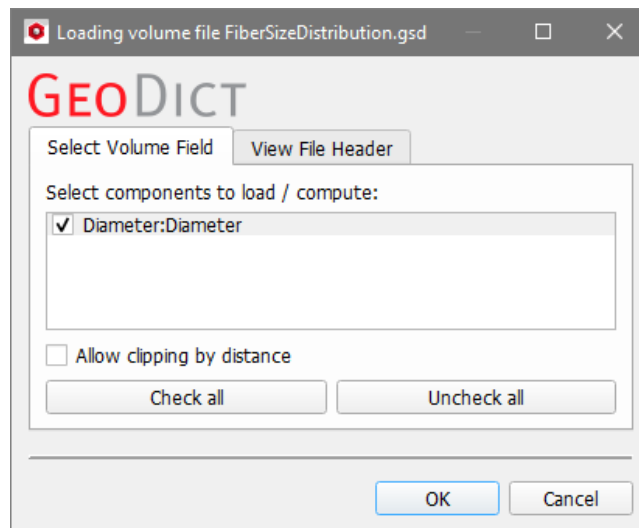

Then, deselect the visualization of the structure, by clicking **Yes** in the dialog that pops up (or by choosing **View** in the Menu bar and uncheck the **Structure** box).

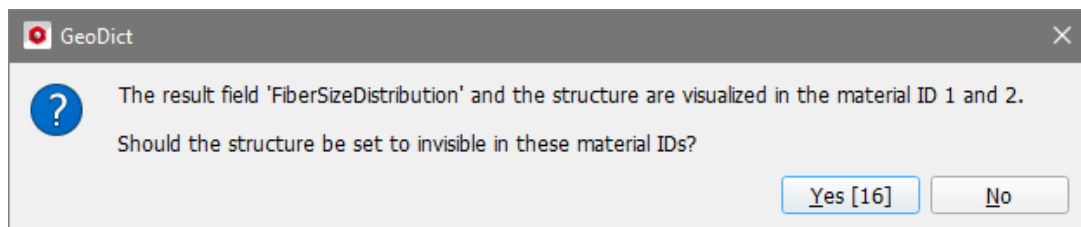

In the **Volume Field** tab of the Visualization panel (above the Visualization area), with the **Visibility** set to material IDs 01 and 02, only the fibers are shown and not the pore space.

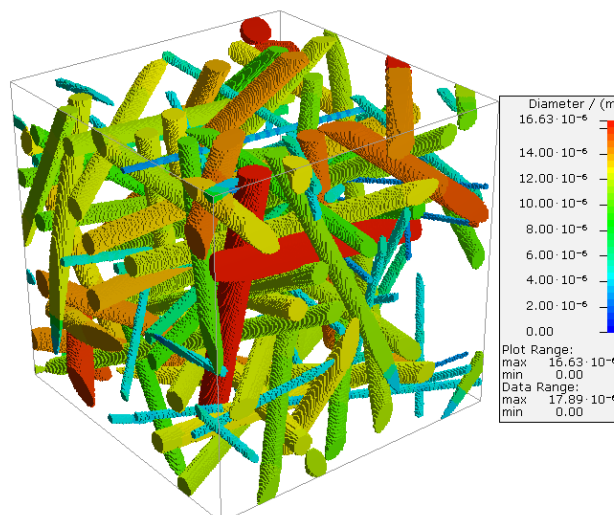

The buttons for data management available at the bottom of the Result Viewer are explained in detail in the [Result Viewer](#) handbook.

The units of length are meters (m) because, internal to GeoDict, all units are SI (Système International d'Unités) for which meter is the base unit for length.

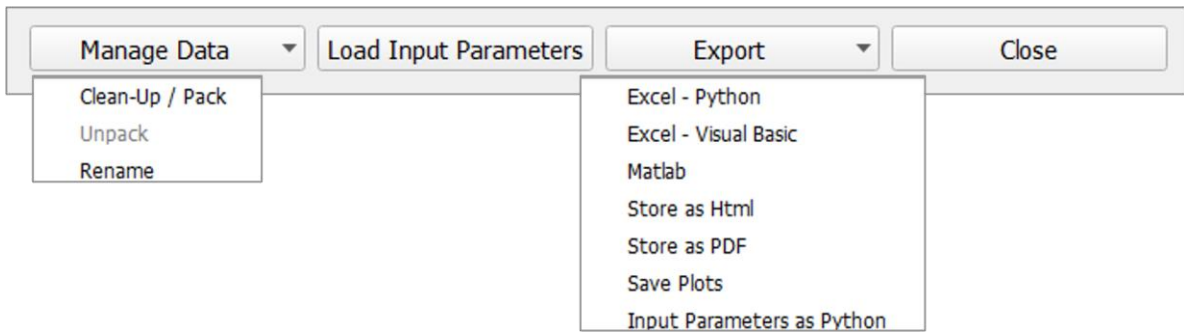

ESTIMATE FIBER ORIENTATIONS

Start with a 3D-model of a fibrous material that has been loaded in memory and is displayed in the Visualization area. In the **FiberFind** section, select **Estimate Fiber Orientations** from the pull-down menu and click the **Options' Edit...** button.

In the opening **Fiber Diameter Estimation** dialog, enter the desired **Result File Name (.gdr)**, and select the **Material to analyze** as explained on page [10](#).

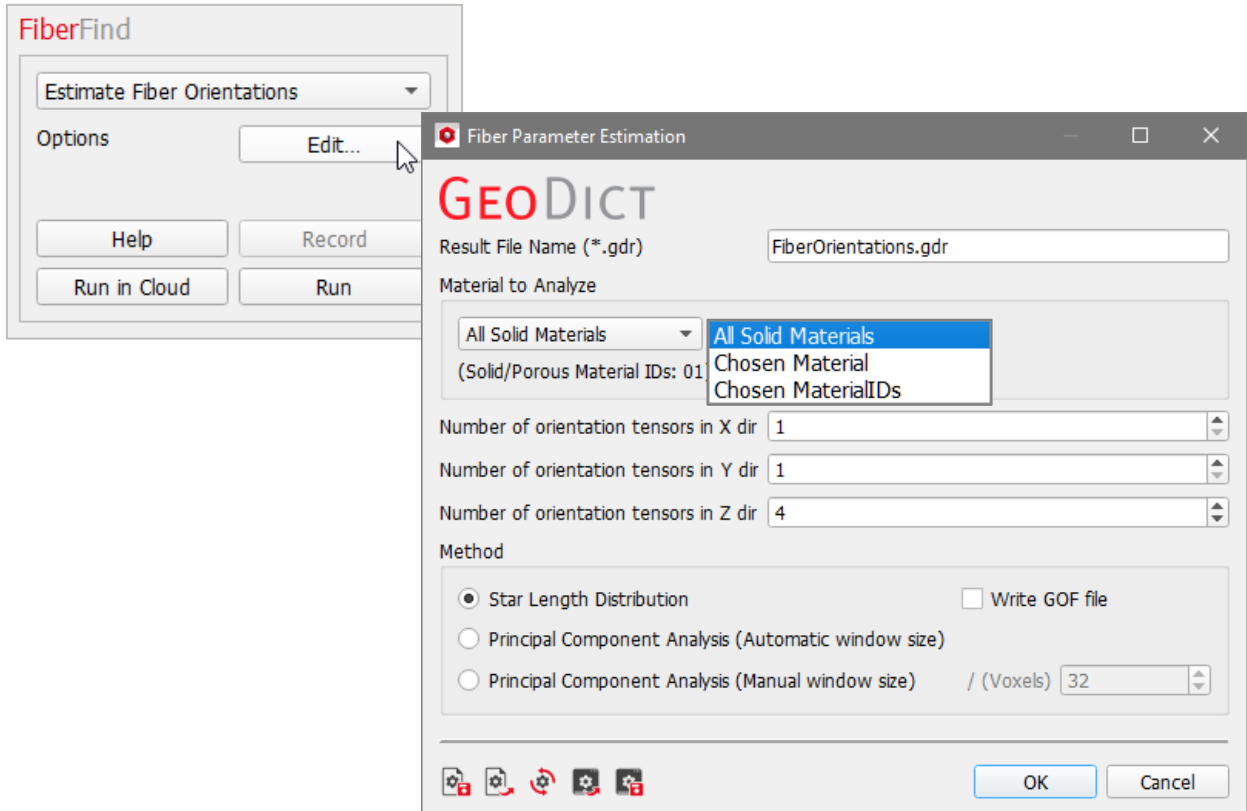

For homogeneous materials, without variations in orientation, the domain can be analyzed as a whole and, therefore, the **Number of orientation tensors in X direction, in Y direction, and in Z direction** can be set to 1, 1, and 1.

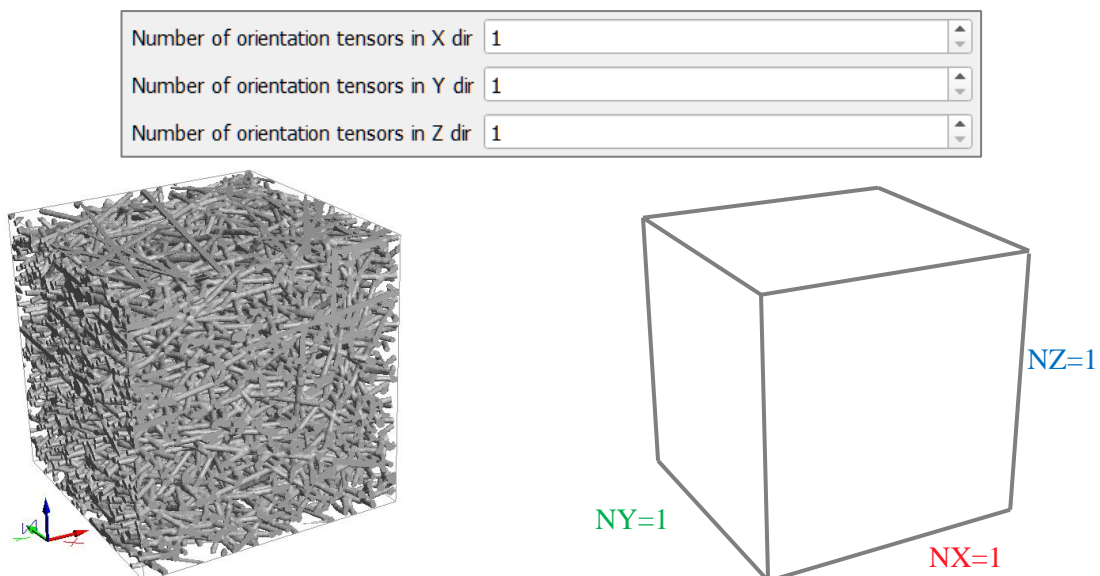

Identification of binder and fibers, and analysis of fiber properties

For non-homogenous fibrous materials, where fiber layers with varying orientations are present, the domain must be subdivided into blocks and an orientation tensor can be estimated for each block. The partition allows to analyze fiber orientation in these diverse areas of the domain, instead of having to cut the structure in parts and to analyze them separately.

The size of the blocks is defined by setting the **Number of orientation tensors**, for which values can be set, e.g. to 3, 3, and 2, producing 18 blocks.

Number of orientation tensors in X dir	3
Number of orientation tensors in Y dir	3
Number of orientation tensors in Z dir	2

These 18 blocks are labeled later in the result file as Block 0,0,0, Block 1,0,0, Block 2,0,0, Block 0,1,0, Block 1,1,0, etc.

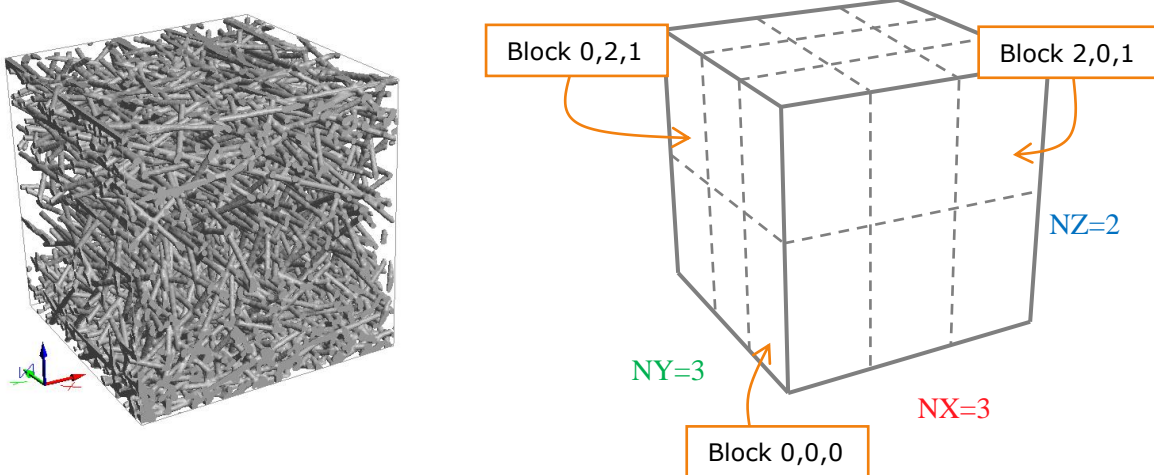

Next, choose a method for the analysis of fiber orientation: **Star Length Distribution** (SLD) or **Principal Component Analysis** (PCA, Automatic or Manual window size).

Method	
<input checked="" type="radio"/> Star Length Distribution	<input type="checkbox"/> Write GOF file
<input type="radio"/> Principal Component Analysis (Automatic window size)	
<input type="radio"/> Principal Component Analysis (Manual window size)	/ (Voxels) 32

The Star Length Distribution (SLD) method works on a per-voxel basis. For each voxel, it analyzes chord lengths through the voxel for a pre-defined set of directions. The relative length of the chords gives the per-voxel orientation tensor. Then, the tensors are averaged over all voxels included in a block.

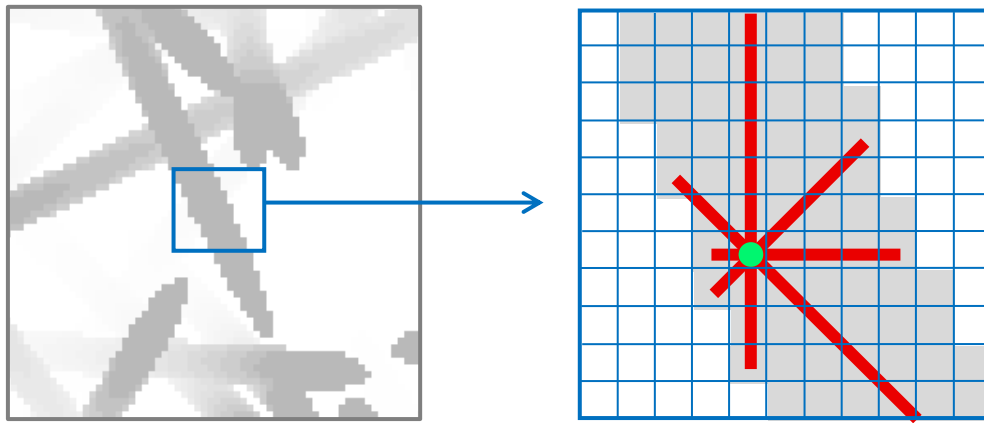

The PCA method is an alternative approach that subdivides the domain into windows of a given size. The size of the window can be automatically determined based on maximum fiber diameter (Automatic window size) or manually entered in voxels (Manual window size).

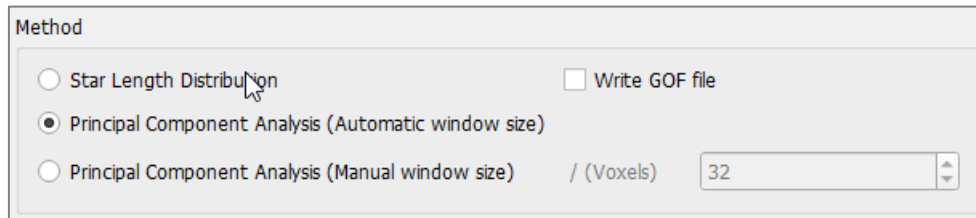

The subdivision into windows is applied to eliminate the influence of fiber crossings. Our PCA-based algorithm identifies fiber fragments and analyzes the direction tensor within each window. Then, it averages the direction tensors over all windows within a block to obtain the orientation tensor for that block.

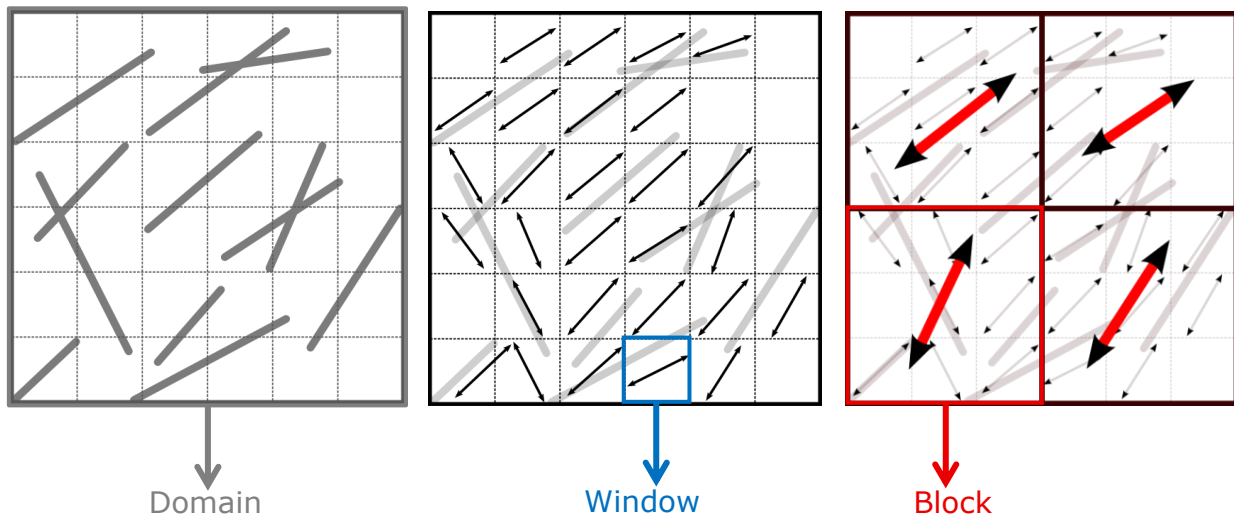

When needed, check **Write GOF file** to save a GeoDict Orientation File (GOF) with the per-voxel fiber orientation information.

ESTIMATE FIBER ORIENTATION RESULTS

After the calculations, a Result Viewer opens showing the calculated fiber orientation tensors and solid volume fraction for each block. The tensor describes the statistical distribution of orientation in that particular block.

With an undivided domain (1x1x1 blocks), only one tensor for the complete domain appears in the Result Viewer.

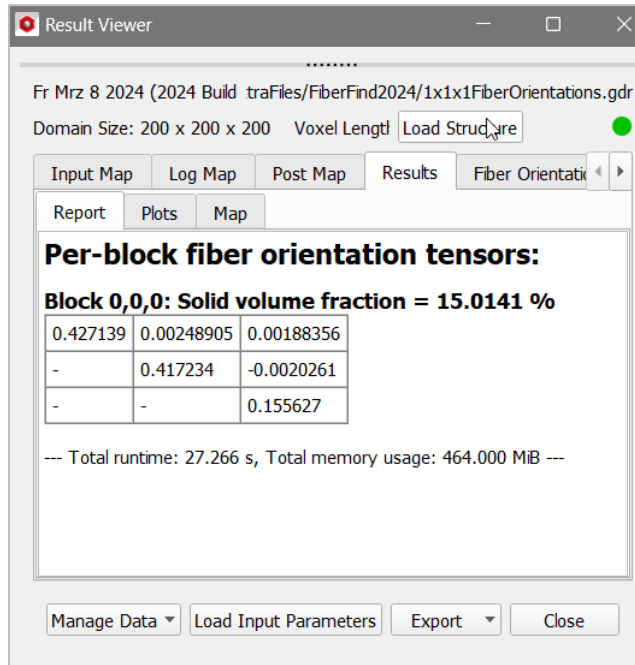

With the domain subdivided into 3x3x2 blocks, the number of tensors is 18.

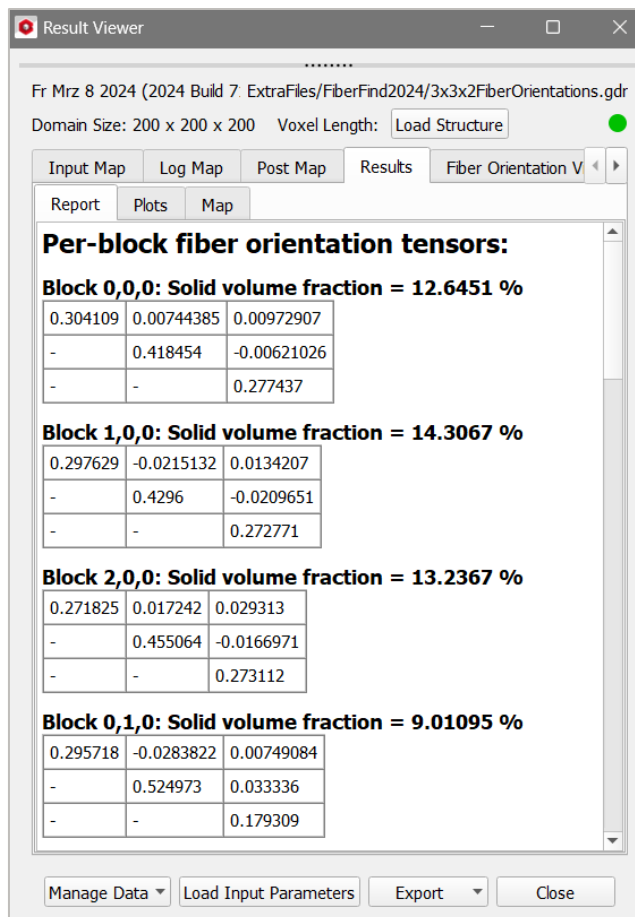

A detailed description of the orientation tensor and its components is also given in the [FiberGeo handbook](#) (see [Orientation](#)).

The components of the orientation tensor in X, Y and Z direction are shown for all three coordinate directions in the **Results - Plots** subtab.

These components are shown here in a single Result Viewer: on the left for the undivided domain and on the right for the second domain subdivided into 3x3x2 blocks.

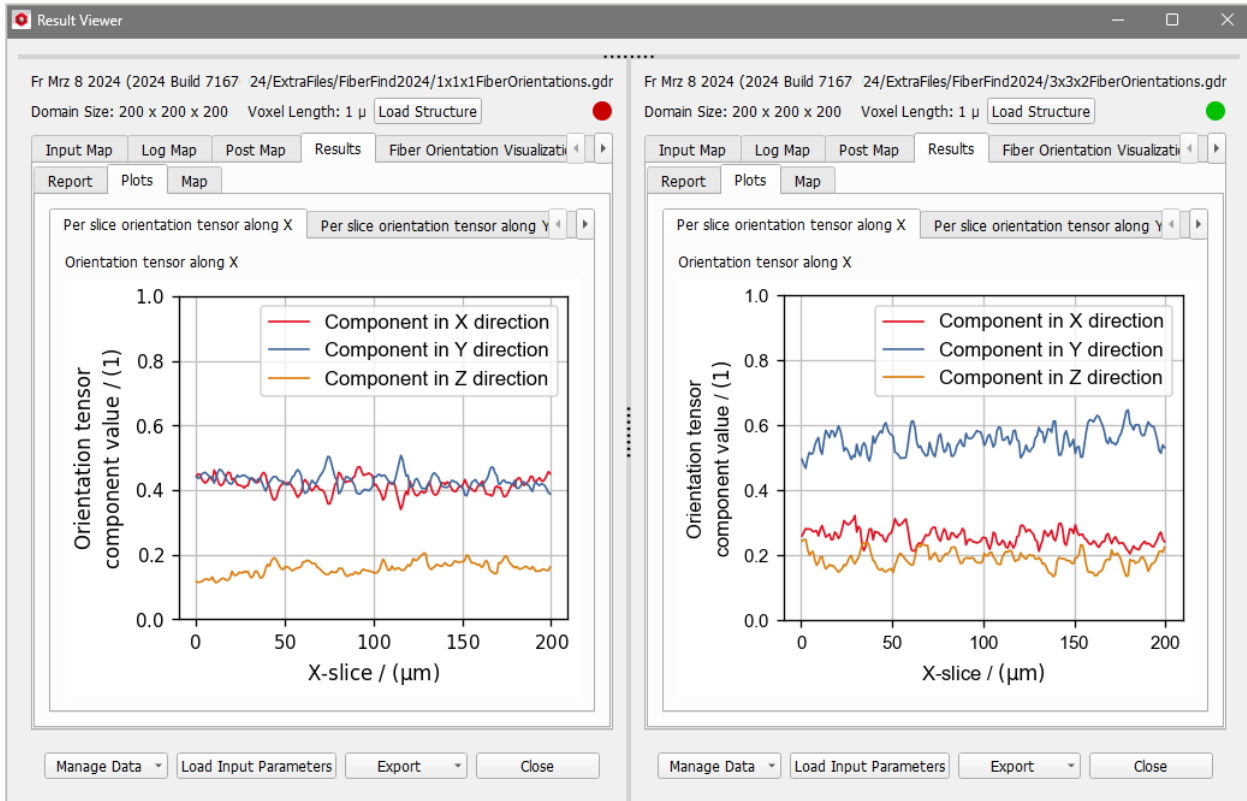

The fiber orientation in the blocks can be visualized by clicking **Load .stl** to get the **3D Orientation Arrows** under the **Fiber Orientation Visualization** tab.

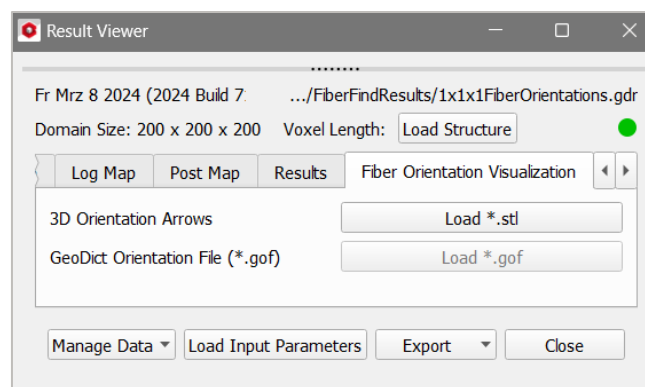

The fibers of the structure obscure the orientation arrows. Go to the menu bar and turn off the visualization of the fibers by un-checking **View** → **Structure**. Orientation arrows are visible only in 3D view. Switch to it by selecting **View** → **3D Rendering**.

The **direction** of an arrow in a particular block shows the main fiber orientation in the block, and its length shows the strength of this main fiber orientation. The **color** of the arrows indicates the fiber solid volume fraction (SVF) in a block. The color range is green-yellow-orange-red. Assignment of color in a block depends on its SVF relative

Identification of binder and fibers, and analysis of fiber properties

to the SVF of the other blocks. The block with the highest SVF gets a green arrow. The block with the lowest SVF gets a red arrow. When there is only one block (homogeneous material), the arrow is red.

For a homogeneous material structure (no subdivision), only one arrow appears in the center of the single block. Here, the short arrow pointing in the X-direction indicates that although the fibers' main orientation is on the X-axis, there is a great deal of dispersion.

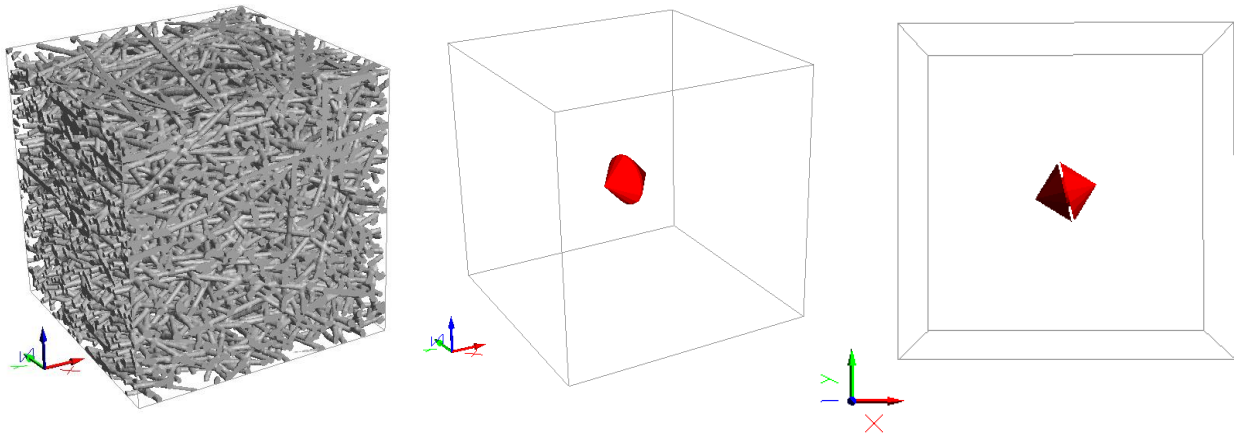

For a heterogeneous material structure, divided into 3x3x2 blocks, 18 arrows appear that occupy the centers of each of the 18 blocks. All arrows are oriented closely to the Y-axis. The range of colors indicates that the SVF of some blocks (green arrows) is higher than that of others (red arrows).

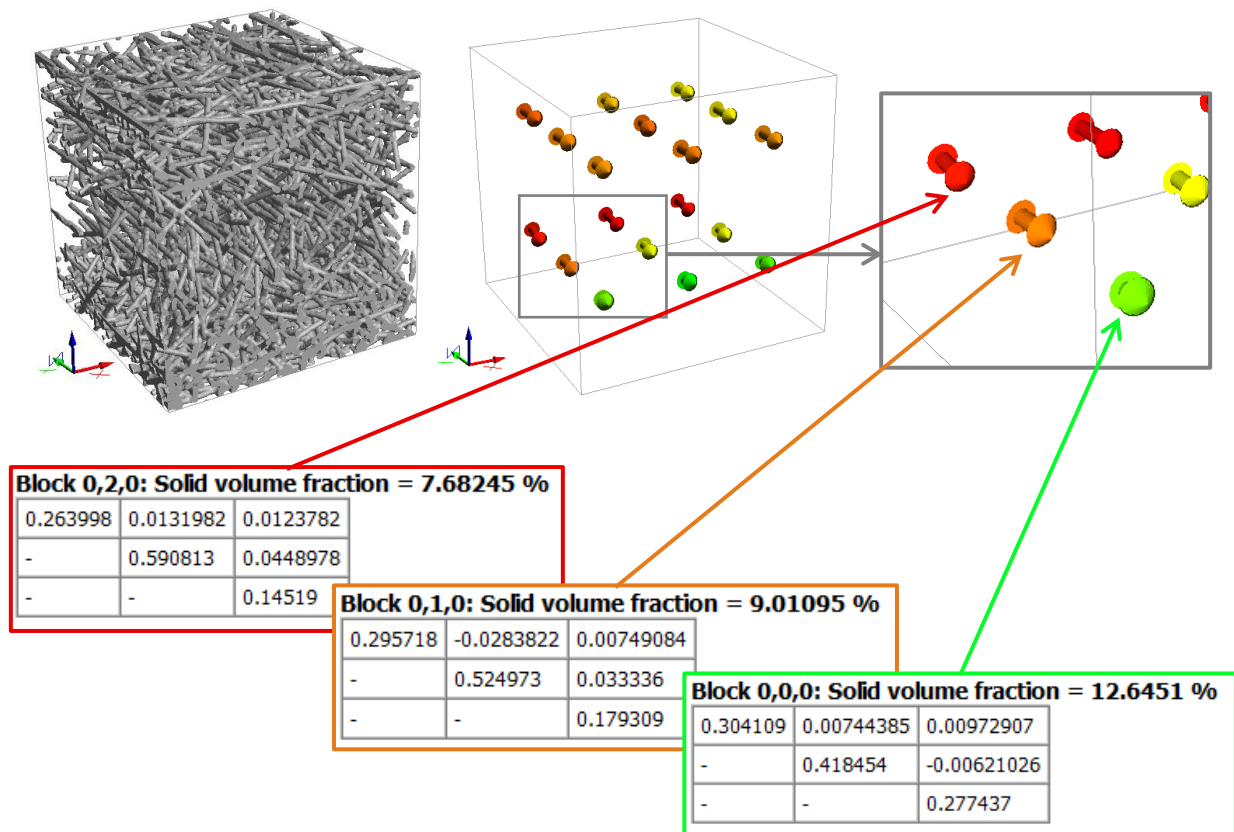

Besides the 3D orientation arrows it is possible to visualize the GOF file (if one was calculated). Click **Load *.gof** under the **Fiber Orientation Visualization** tab of the Result Viewer.

Select, e.g., to load the Orientation:AngleToX to get for each fiber segment the angle to the x axis.

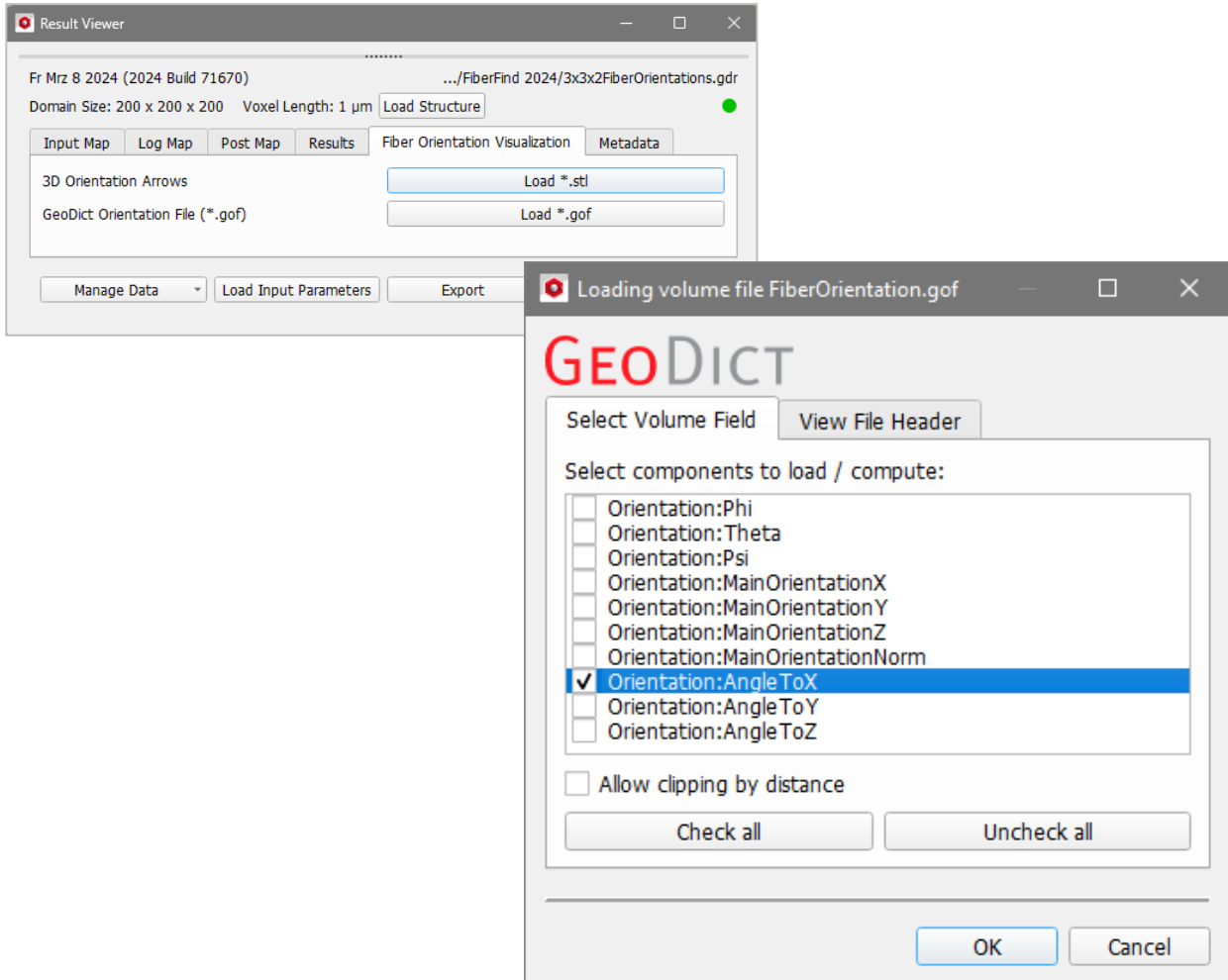

In the Visualization panel, above the Visualization area, uncheck the check box in the **Structure** tab. In the **Volume Field** tab, deselect **Visibility** for the pore space (Material 00).

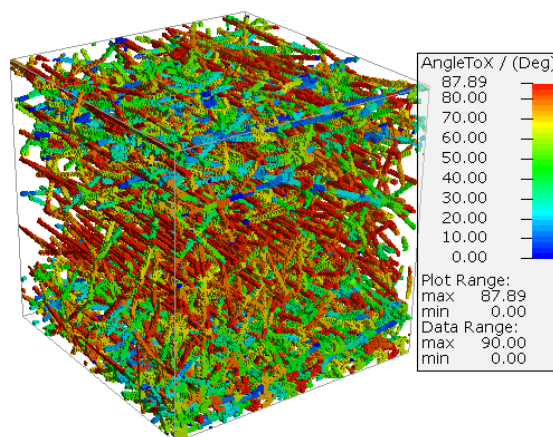

ESTIMATING FIBER ORIENTATION IN LAYERED MATERIALS

For a layered heterogeneous material, **FiberFind** can be used to estimate the fiber orientation in the layers by subdividing the domain according to the layers. For example, the domain of a material with three layers would be subdivided as follows:

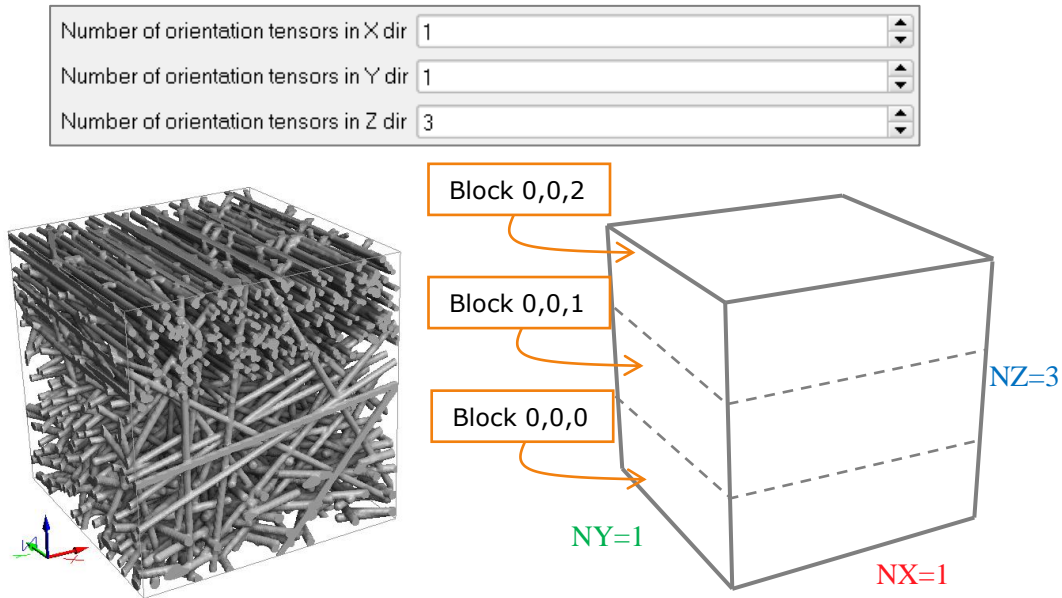

When the calculations with **FiberFind** are finished, the Result Viewer for the fiber orientation result file (.gdr) opens showing the calculated fiber orientation tensors and solid volume fraction for each of the three blocks. The highest fiber solid volume fractions are in the top (Block 0,0,2) and bottom (Block 0,0,0) layers as can be seen in the **Results - Report** subtab.

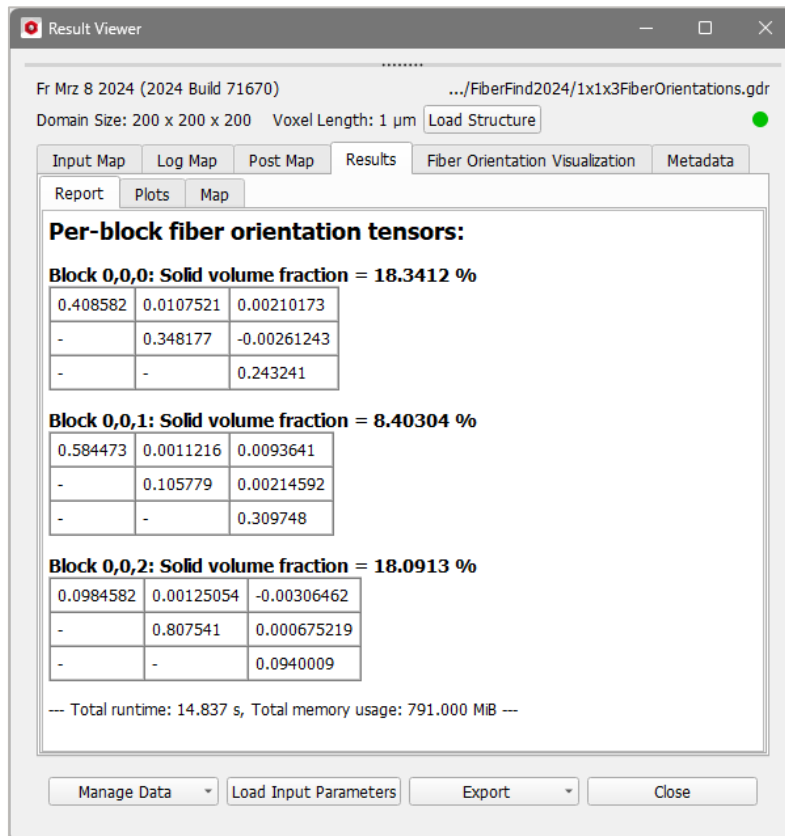

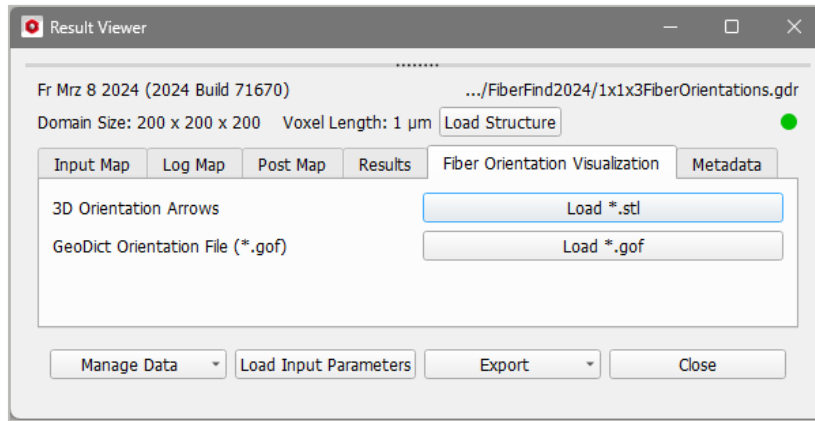

The main orientation of the top layer (Block 0,0,2) is in Y-direction, the main orientation of the middle layer (Block 0,0,1) is in X-direction and the main orientation of the bottom (Block 0,0,0) layer is in the X-Y-direction.

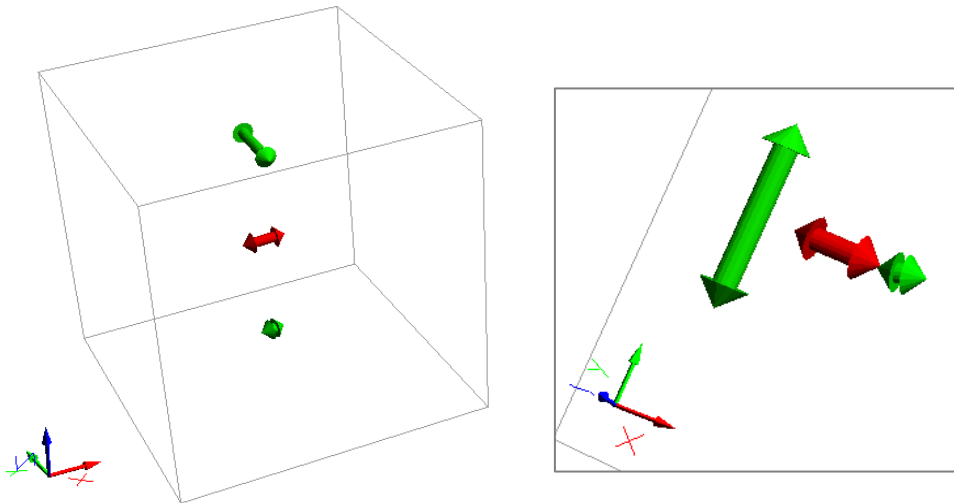

Whereas a great majority of fibers in the top layer are oriented in the Y-direction, the orientation in the middle layer and, particularly in the bottom layer, is more scattered.

ESTIMATE FIBER CURVATURE

An analytic representation of the fibers (.gad file or .gdt file containing analytic data in GeoDict) is used for the estimation of curvature and curliness in FiberFind.

If such analytic data is available and loaded into the GeoDict GUI, the algorithm works directly on this representation, which can be created e.g. by running a fiber identification with FiberFind (see [Identify Fibers](#)). The computation of curvature works for all fibers of one of the curved fiber types available in FiberGeo (Curved Circular, Curved Hollow, Curved Rosetta, Curved Elliptical, Curved Cellulose, Curved Rectangular, Curved Angular). For more details, see the [FiberGeo](#) handbook, section **Create**, subsection **Fiber Options-Fiber Type**.

If no analytical data is available, i.e., the computation is started on a voxel image, the analytic fiber identification algorithm (i.e., the one available for the Identification Method **Analytic**, see page [40](#)) is applied to the structure before the curvature estimation. In that case a warning appears to inform the user:

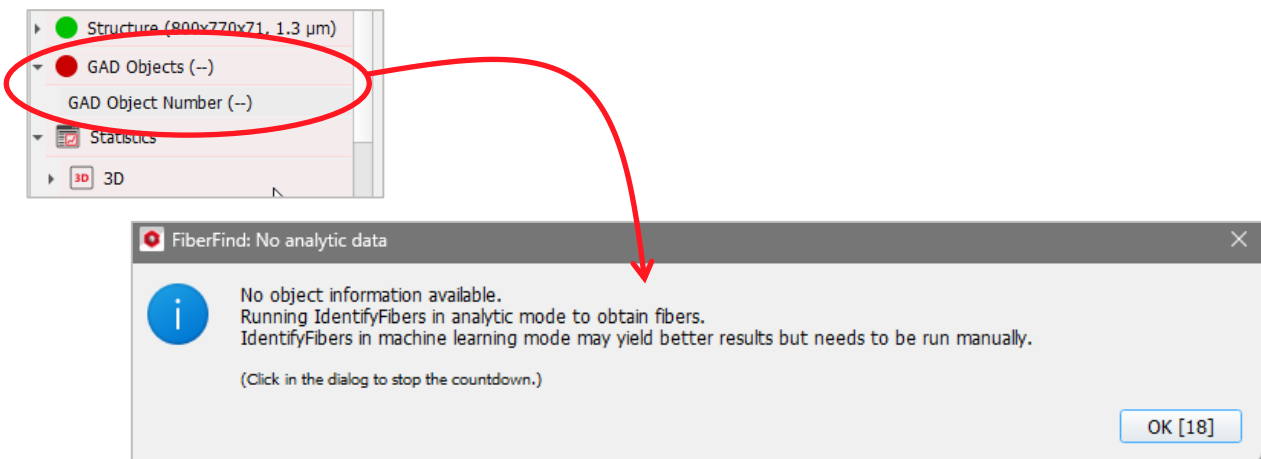

For the estimation of curvature and curliness in FiberFind, in the **FiberFind** section, select **Estimate Fiber Curvature** from the pull-down menu and click the **Options' Edit...** button.

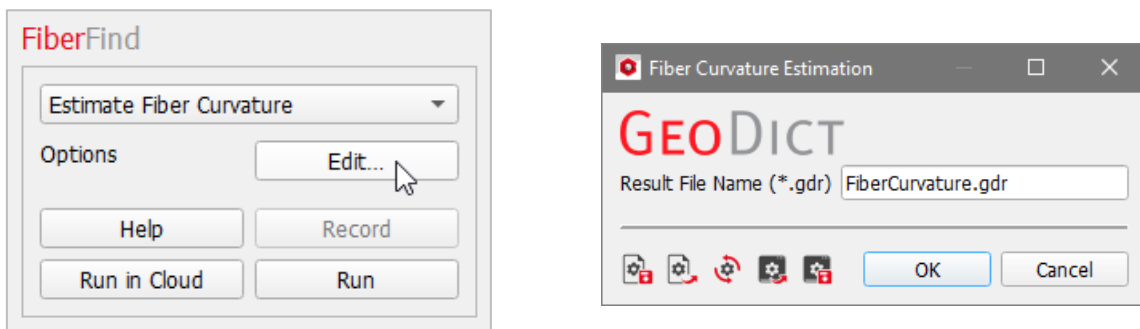

In the **Fiber Curvature Estimation** dialog, enter the desired **Result File Name (.gdr)**.

After the fiber curvature calculations are finished, a Result Viewer for the FiberCurvature.gdr file opens.

Under the **Results - Report** tab, it displays the identified **Average fiber curvature** (and its **Standard deviation**) and the **Average fiber Curl-Index** for the given **Number of analyzed fibers**.

Below, a table gives the distribution of fiber curvature, listing the **Count Fraction (%)** for the ranges of calculated fiber curvatures.

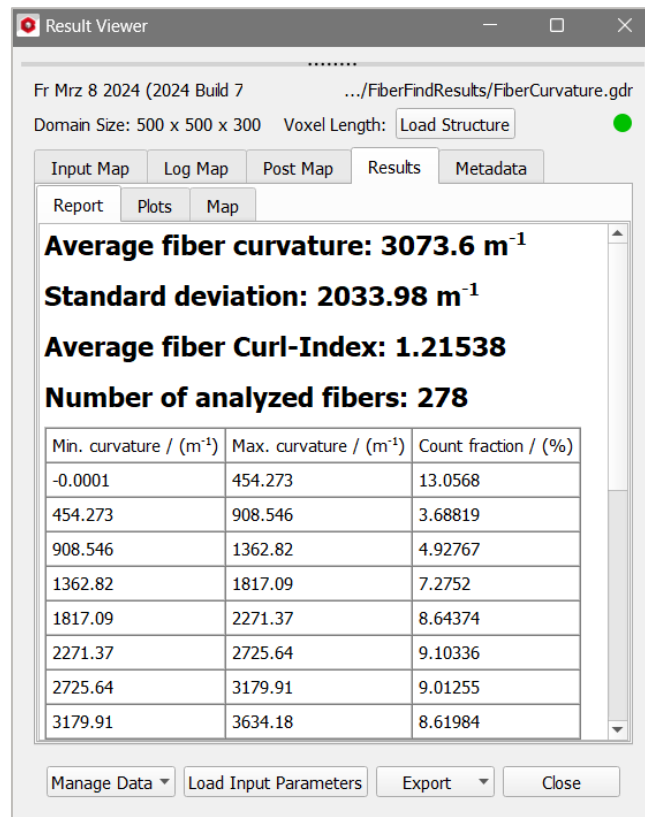

Under the **Results - Plots** sub-tab, diagrams show the distribution of fiber curvature and fiber curl-index, corresponding to the count fractions for curvatures and curl-index of fibers present in the domain.

In our example, the highest count fractions correspond to fibers with low curvature and low curl-index.

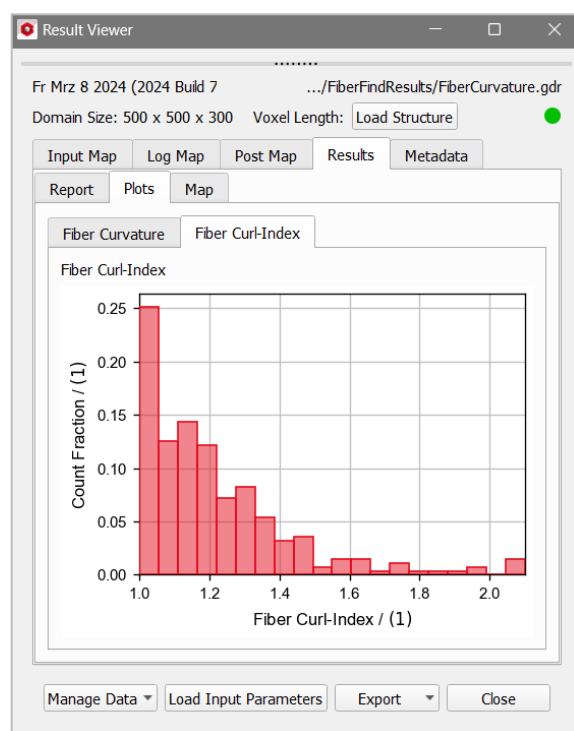
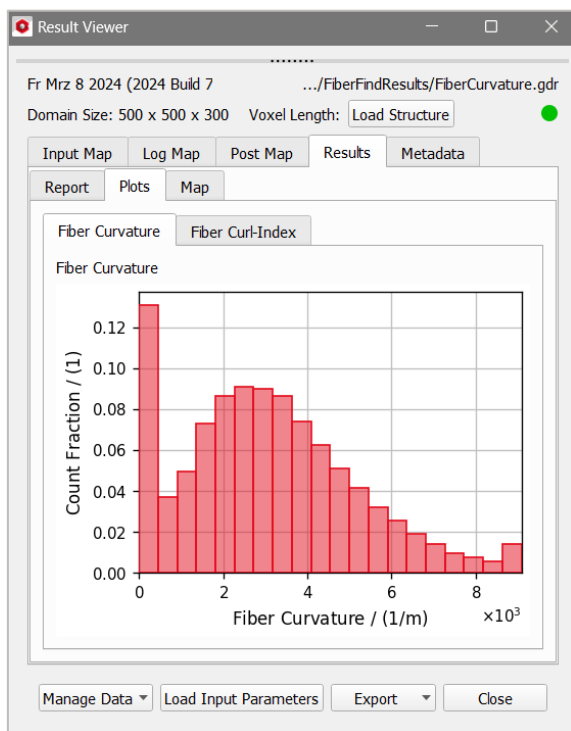

REPRODUCING FIBROUS MEDIA USING FIBERFIND AND FIBERGEO

The values of the orientation tensors and the calculated diameters can be entered in **FiberGeo** to generate a matching digital material model.

Start with the values estimated by **FiberFind** for the fibrous material: the average fiber diameter and the diameter distribution for the whole domain, as well as the fiber orientation tensors for each block. This diameter distribution and the per-block orientation tensors can now be entered in **FiberGeo** to reproduce the fibrous material.

Select **Model** → **FiberGeo** in the menu bar and click the **Options' Edit...** button in the **FiberGeo** section.

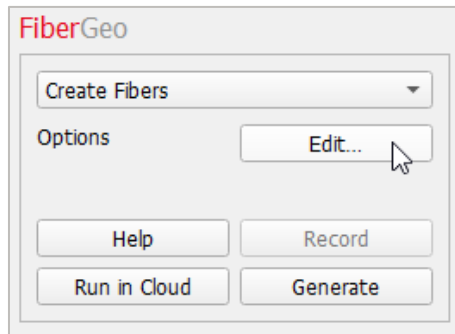

In **FiberGeo**, go to the **Fiber Options** tab and begin entering as many fibers of type Short Circular or Infinite Circular as the number of blocks in which the domain has been subdivided. For a homogeneous material, this is a single fiber type. For a layered heterogeneous material, this is a fiber type per media layer. In **FiberGeo**, it is possible to use up to 8 different fiber types.

Later, all fibers can be assigned to the same Material ID.

Set the **Percentages are** as Volume % (bottom right) to be able to define the desired fraction of the total volume of the fibrous structure according to an Object Solid Volume Percentage (SVP) value. Please refer to the [FiberGeo handbook](#) for a more detailed description of the different **FiberGeo** Create Options.

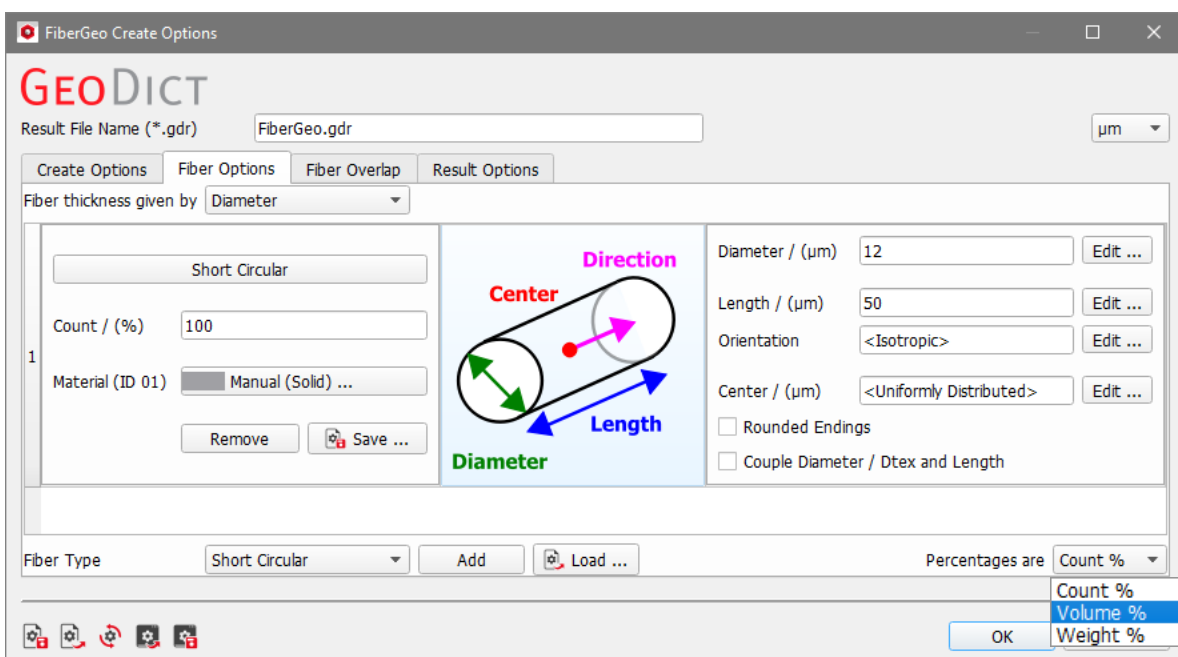

HOMOGENEOUS FIBROUS MEDIA

For a homogeneous material (no layers), for the single fiber type, use the data from a fiber diameter result file (*.gdr) obtained with **FiberFind** and, for **Diameter**, enter the value of the estimated **Average inner diameter**.

Alternatively, click the **Diameter's Edit...** button and choose **Gaussian** (or Log-Normal) to enter the values of the **Average inner diameter** and the **Standard deviation** from the fiber diameter result file.

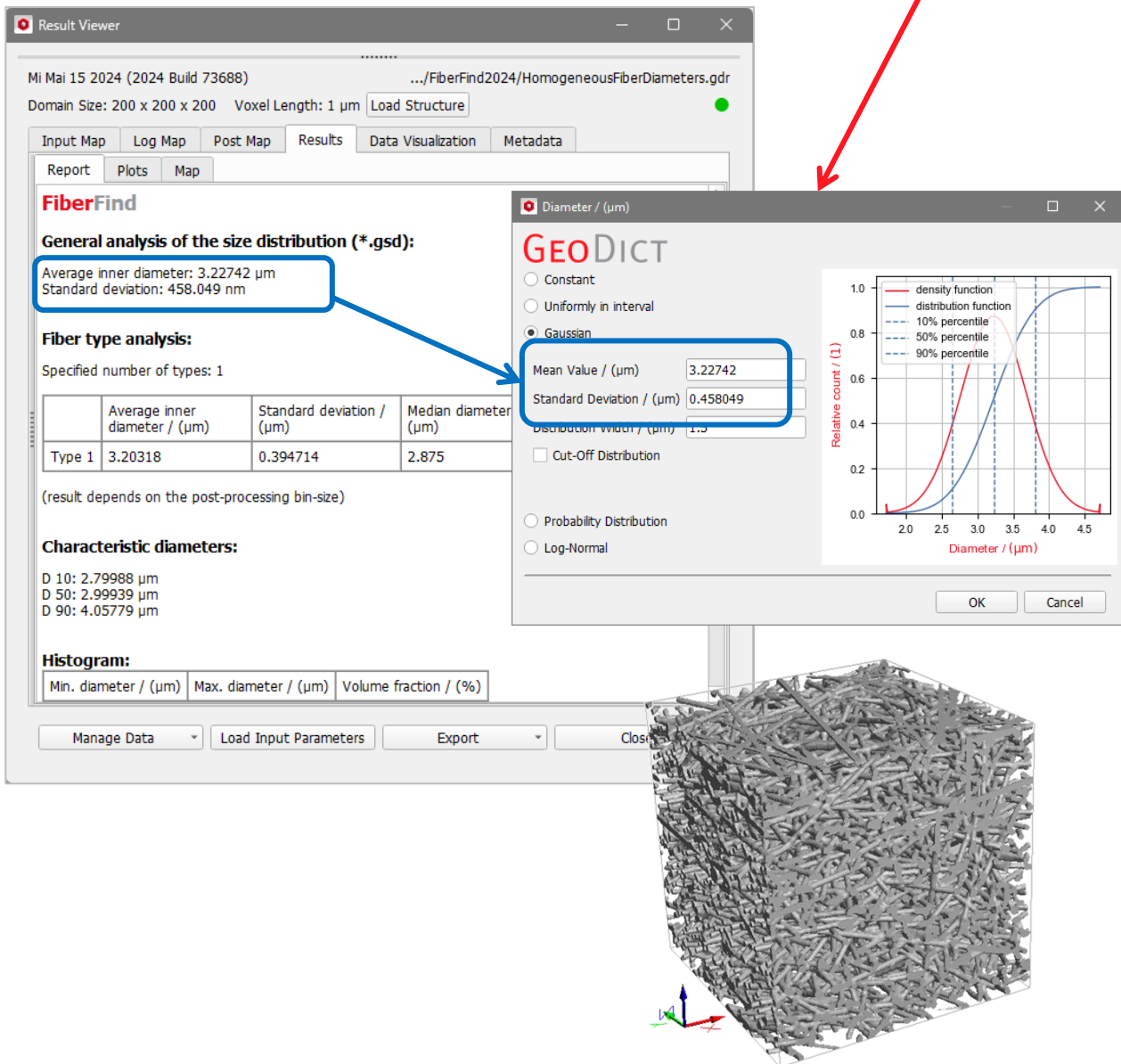
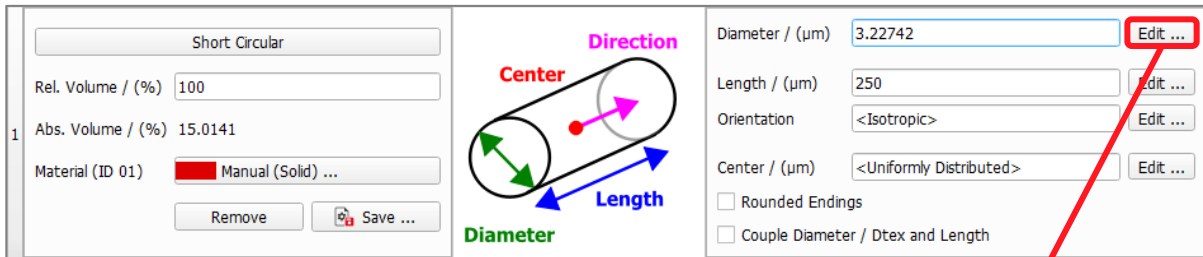

It is also possible to choose **Probability Distribution** and to enter a stepwise distribution, e.g. from the histogram values of the fiber diameter count estimation.

Identification of binder and fibers, and analysis of fiber properties

Enter a **Length** that fits to the length of fibers in the structure (e.g. the length estimated during fiber identification (see [Identify Fibers](#)).

For the example shown above, with fibers having their start and end points beyond the domain, enter a **Length** that is larger than the largest side of the domain. For a domain of 200 x 200 x 200 used here, enter e.g. a length of 250 μm . Infinite circular fibers could be chosen as fiber type as well here. They already extend beyond the domain.

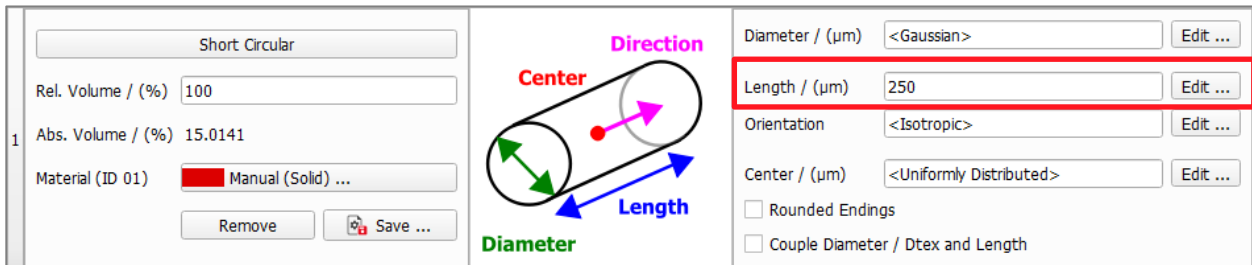

Using a fiber orientation file (*.gdr) obtained with **FiberFind**, click now the **Orientation Edit...** button to enter these computed values.

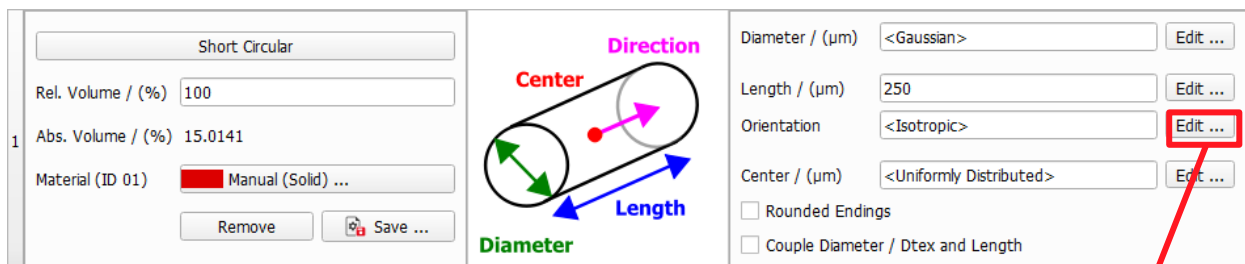

Result Viewer

Fr Mrz 8 2024 (2024 Build 7 .../FiberFindResults/1x1x1FiberOrientations.gdr

Domain Size: 200 x 200 x 200 Voxel Length: Load Structure

Input Map Log Map Post Map Results Fiber Orientation

Report Plots Map

Per-block fiber orientation tensors:

Block 0,0,0: Solid volume fraction = 15.0141 %

0.427139	0.00248905	0.00188356
-	0.417234	-0.0020261
-	-	0.155627

--- Total runtime: 27.266 s, Total memory usage: 464.000 MiB ---

Manage Data Load Input Parameters Export

Orientation

GEODICT

Isotropic

Anisotropic Direction

Direction Mode Orientation Tensor

Anisotropy 1 1

Anisotropy 2 1

Phi / ($^{\circ}$) 90.0000

Euler Angles Theta / ($^{\circ}$) 180.0000

Psi / ($^{\circ}$) 0.0000

0.42723	0.00248611	0.00187929
-	0.417382	-0.00200235
-	-	0.155627

Orientation Tensor

Normalize + Calculate Anisotropy Parameters

Anisotropic Orientation

Given Directions

In XY-Plane

Angle Around Direction

OK Cancel

Now, under the **Create Options** tab of **FiberGeo**, enter the estimated **Solid Volume Fraction** as **Object Solid Volume Percentage** in the Stopping Criterion panel. There are no layers and, thus, the calculated SVF corresponds to the **Object Solid Volume Percentage** of the complete media.

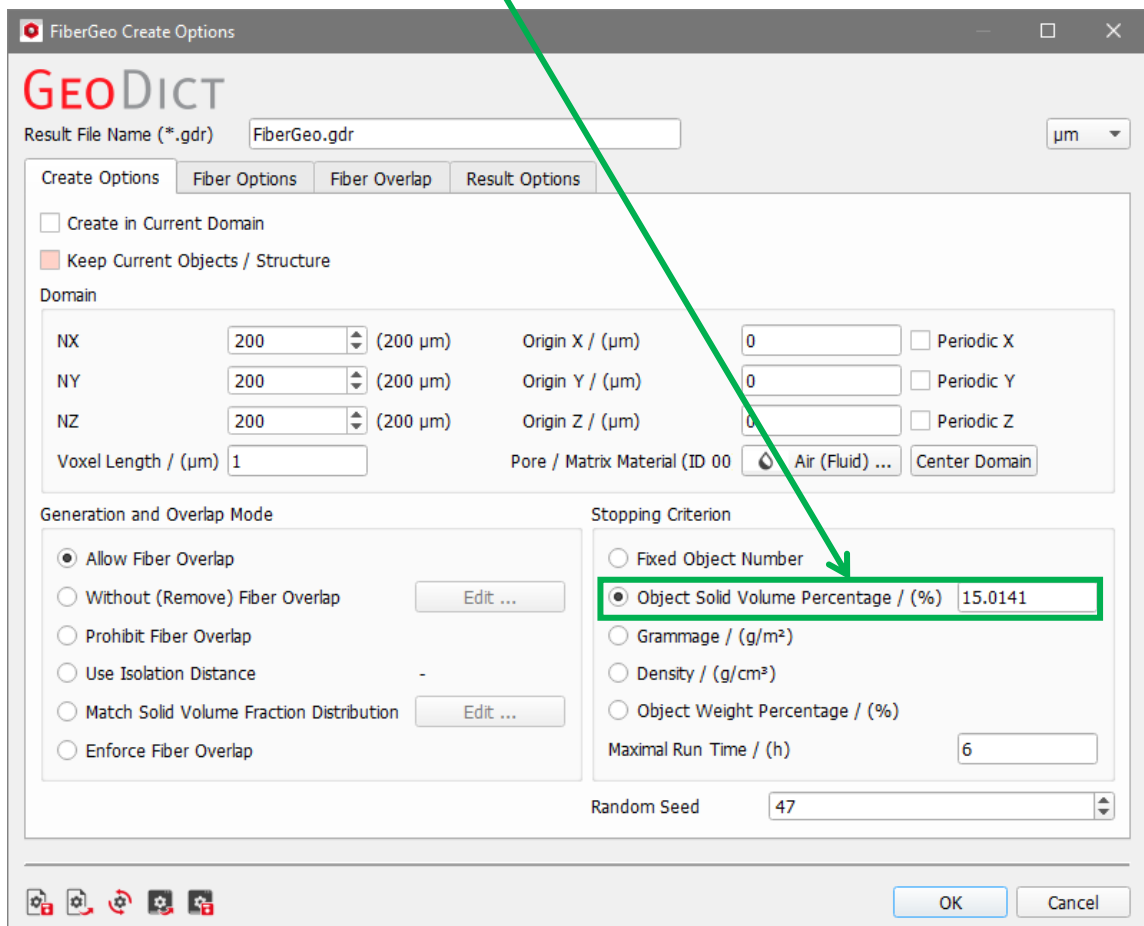
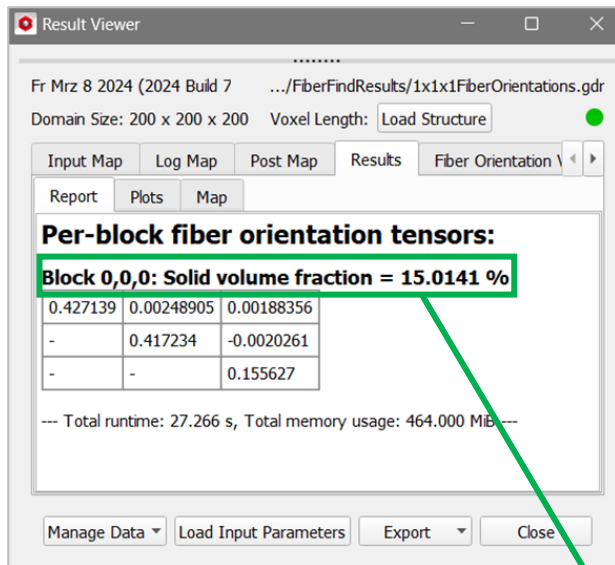

Remember to set the correct domain size (**NX**, **NY**, **NZ**) and **Voxel Length** in the Domain panel (**Create Options** tab).

Click **OK** to close the **FiberGeo Create Options** dialog and click **Generate** in the **FiberGeo** section.

The reproduced fibrous material model appears in the Visualization area, matching the values estimated by **FiberFind** for the 3D material model obtained from importing (μ)CT images.

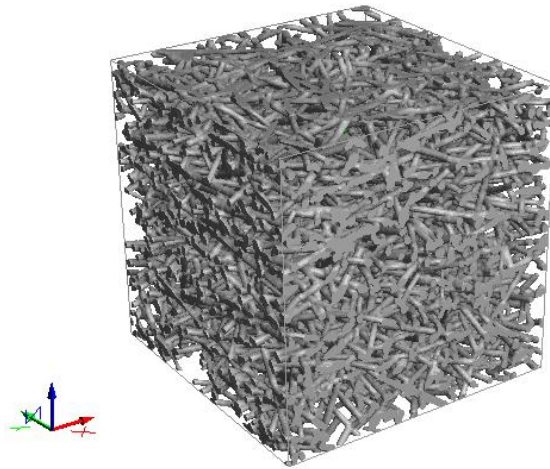

HETEROGENEOUS (LAYERED) FIBROUS MEDIA

For a heterogeneous material (layered), add as many fiber types as layers are in the media, corresponding to the blocks estimated by computations with **FiberFind** (for example, on a 3D material structure model obtained from importing a (μ)CT image).

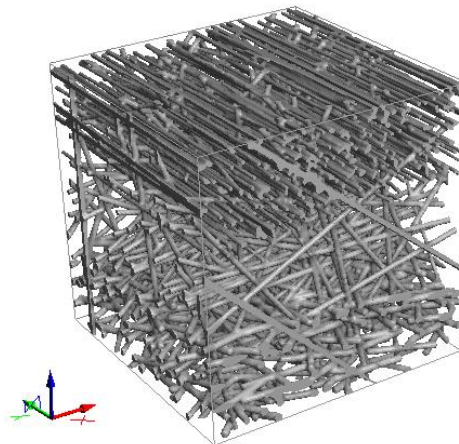

To enter the fiber type and the fiber diameter for each of them, use the data from the fiber diameter estimation result file (*.gdr) obtained with **FiberFind** and enter the estimated **Average inner diameter** directly.

Alternatively, click the **Diameter Edit...** button for each fiber type, choose **Gaussian** (or Log-Normal), and enter the value of the estimated **Average inner diameter** and the value of **Standard deviation** for all fiber types (as shown above on page [29](#)).

Notice that the fiber diameters of the different layers look fairly similar in the example shown. Because of this, only one fiber type (short circular) and the same values for the Gaussian distribution are selected. If the diameters should be different in each layer, it is possible to choose three different fiber types and a different diameter distribution for each layer under the **Fiber Options** tab in **FiberGeo**.

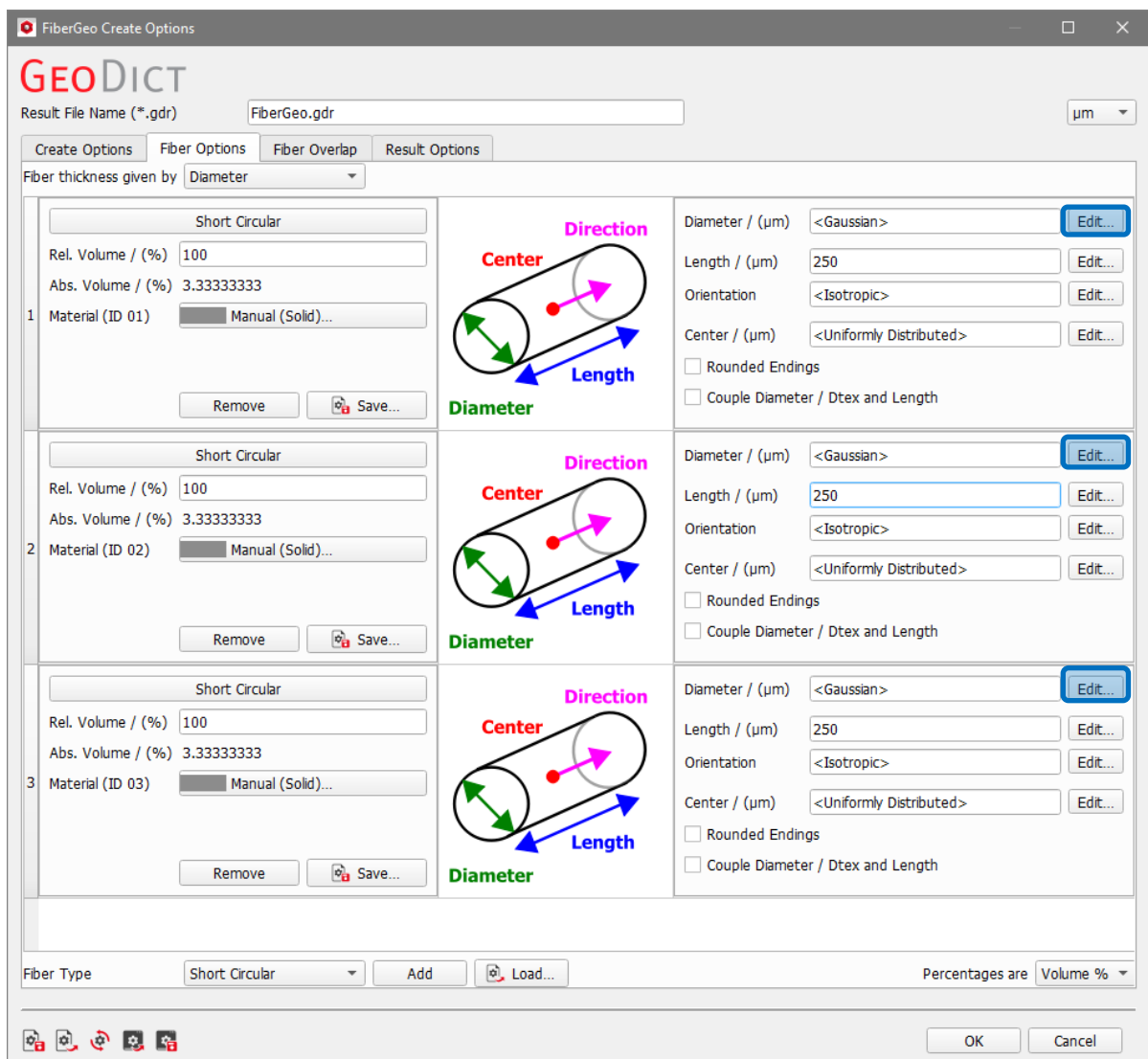
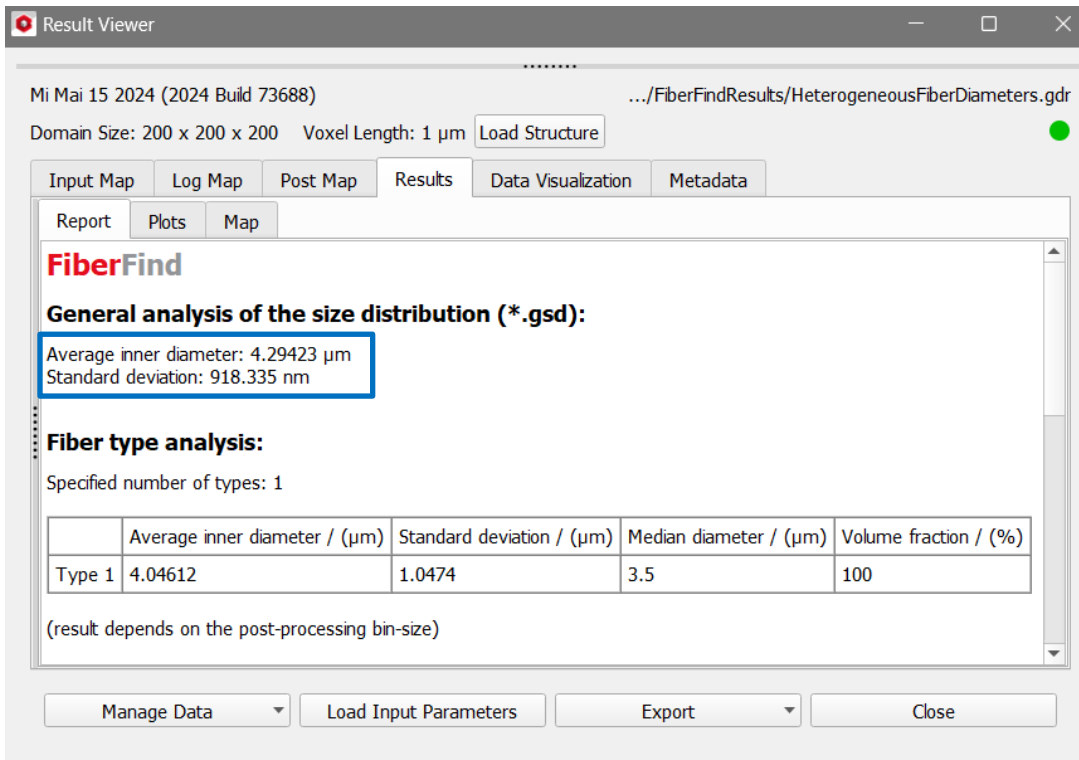

Identification of binder and fibers, and analysis of fiber properties

In the example shown, most fibers do not end inside the domain. For short circular fibers, enter therefore a **Length** that is larger than the largest side of the domain. For example, being the domain 200x200x200, enter a length of 250 μm .

The fiber type Infinite Circular cannot be used here, since we want to model a structure with three different layers and therefore also need to define the center of the fibers for each layer, see below.

From the fiber orientations file (*.gdr), enter the values from the orientation tensors calculated for each block (layer) by clicking the **Orientation's Edit...** buttons in the right panels.

The image displays a software interface for fiber orientation analysis. The main window, 'Result Viewer', shows the 'Per-block fiber orientation tensors' for three blocks. Each block's tensor is a 3x3 matrix. Blue arrows point from these tensors to three separate 'Orientation' dialog boxes, each for a specific block. The dialog boxes are titled 'Block 0,0,0', 'Block 0,0,1', and 'Block 0,0,2'. Each dialog box has a 'GEO-DICT' header and a 'Block' label. The 'Anisotropic Direction' radio button is selected. The 'Orientation Tensor' field is populated with the values from the corresponding block in the 'Result Viewer'. The 'Normalize + Calculate Anisotropy Parameters' button is visible at the bottom of each dialog box.

Per-block fiber orientation tensors:

Block 0,0,0: Solid volume fraction = 18.747 %

0.4135	0.0101681	-0.00474351
-	0.343832	0.00361791
-	-	0.242668

Block 0,0,1: Solid volume fraction = 8.294 %

0.581382	-0.00328144	0.000782094
-	0.118961	0.00136107
-	-	0.299657

Block 0,0,2: Solid volume fraction = 17.7374 %

0.0819457	0.00125646	0.00187785
-	0.836602	0.000883724
-	-	0.0814521

--- Total runtime: 29.614 s, Total memory usage: 943.000 MiB ---

Orientation Dialog - Block 0,0,0

GEO-DICT
Block 0,0,0

Isotropic
 Anisotropic Direction

Direction Mode: Orientation Tensor

Anisotropy 1: 1.585
Anisotropy 2: 0.8457

Phi / (°): 37.7818
Euler Angles Theta / (°): 2.8147
Psi / (°): -29.4101

0.4135	0.0101681	-0.00474531
-	0.343832	0.00361791
-	-	0.242668

Normalize + Calculate Anisotropy Parameters

Anisotropic Orientation
 Given Directions
 In XY-Plane
 Angle Around Direction

OK Cancel

Orientation Dialog - Block 0,0,1

GEO-DICT
Block 0,0,1

Isotropic
 Anisotropic Direction

Direction Mode: Orientation Tensor

Anisotropy 1: 1.849
Anisotropy 2: 0.2696

Phi / (°): -160.5822
Euler Angles Theta / (°): 0.4737
Psi / (°): 160.1732

0.581382	-0.00328144	0.000782094
-	0.118961	0.00136107
-	-	0.299657

Normalize + Calculate Anisotropy Parameters

Anisotropic Orientation
 Given Directions
 In XY-Plane
 Angle Around Direction

OK Cancel

Orientation Dialog - Block 0,0,2

GEO-DICT
Block 0,0,2

Isotropic
 Anisotropic Direction

Direction Mode: Orientation Tensor

Anisotropy 1: 1.062
Anisotropy 2: 6.675

Phi / (°): 89.7936
Euler Angles Theta / (°): 26.9975
Psi / (°): 69.8815

0.0819457	0.00125646	0.00187785
-	0.836602	0.000883724
-	-	0.0814521

Normalize + Calculate Anisotropy Parameters

Anisotropic Orientation
 Given Directions
 In XY-Plane
 Angle Around Direction

OK Cancel

Next, for each layer, click the **Center' Edit...** button and place the three types of fibers in layers by setting their centers uniformly in a box.

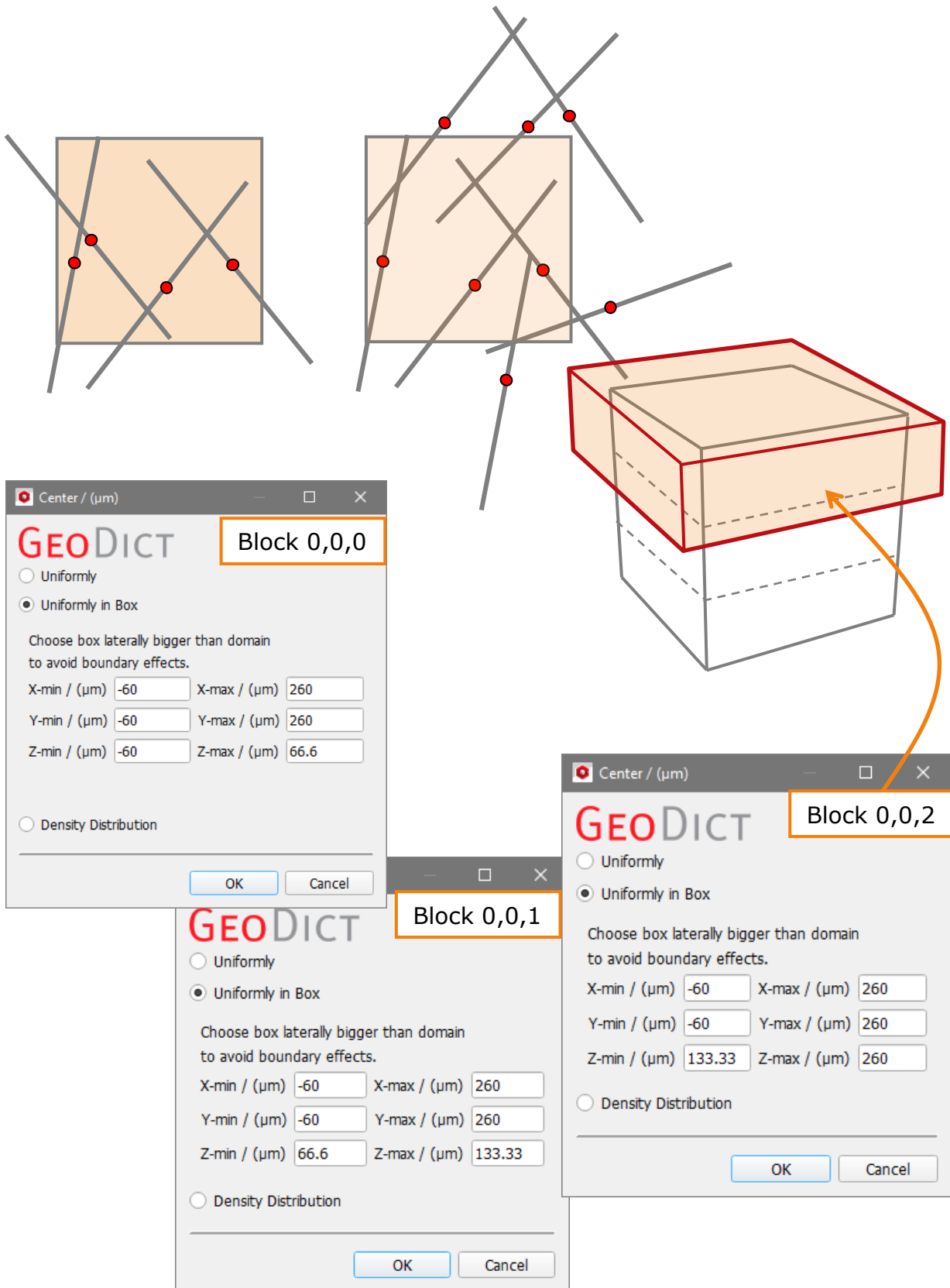

Identification of binder and fibers, and analysis of fiber properties

The box for each layer should be constructed laterally bigger than the domain (200x200x200 μm). When the box is constrained to the domain, only fibers whose centers are inside of the domain are created. For a larger box, also fibers with a smaller part inside the domain are possible (see also the illustration below).

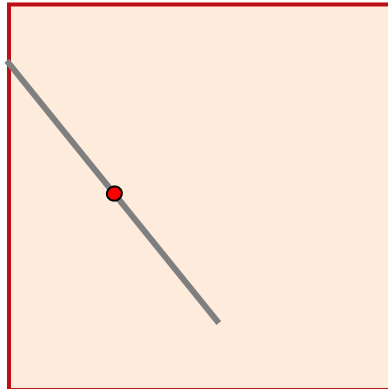

Finally, it is necessary to consider the contribution of every layer (fiber type) to the domain's solid volume fraction (object solid volume percentage).

Under the **Fiber Options** tab, the percentages had been selected to be viewed as **Volume%** (bottom right, see page 28). Enter the estimated solid volume fractions of the three blocks (18.747%, 8.294%, 17.7374%).

After clicking **OK** in the dialog, **FiberGeo** adjusts the percentages automatically to sum up to 100%. For example, for Block 0,0,0 with SVP of 18.747%, the contribution is 41.8662% after percentages are automatically updated.

The screenshot shows the 'Result Viewer' window on the left and the 'Fiber Options' dialog on the right. The 'Result Viewer' displays the 'Per-block fiber orientation tensors' for three blocks. The 'Fiber Options' dialog shows the 'Rel. Volume / (%)' for each block, which are 18.747, 8.294, and 17.7374 respectively. Blue boxes highlight these values in both windows, with arrows pointing from the 'Result Viewer' to the 'Fiber Options' dialog.

Per-block fiber orientation tensors:

Block 0,0,0: Solid volume fraction = 18.747 %

0.4135	0.0101681	-0.00474351
-	0.343832	0.00361791
-	-	0.242668

Block 0,0,1: Solid volume fraction = 8.294 %

0.581382	-0.00328144	0.000782094
-	0.118961	0.00136107
-	-	0.299657

Block 0,0,2: Solid volume fraction = 17.7374 %

0.0819457	0.00125646	0.00187785
-	0.836602	0.000883724
-	-	0.0814521

--- Total runtime: 29.614 s, Total memory usage: 943.000 MiB ---

Fiber Options Dialog:

Short Circular

Rel. Volume / (%) 18.747

1 Abs. Volume / (%) 6.27992514

Material (ID 01) Manual (Solid) ...

Remove Save ...

Short Circular

Rel. Volume / (%) 8.294

2 Abs. Volume / (%) 2.77834849

Material (ID 02) Manual (Solid) ...

Remove Save ...

Short Circular

Rel. Volume / (%) 17.7374

3 Abs. Volume / (%) 5.94172637

Material (ID 03) Manual (Solid) ...

Remove Save ...

Enter the Solid Volume Percentage of fibers in the structure as the Object Solid Volume Fraction in the Stopping Criterion panel, under the **Create Options** tab. You can find the **Statistics** information in the **Status and Modules** field on the left side of the GeoDict GUI.

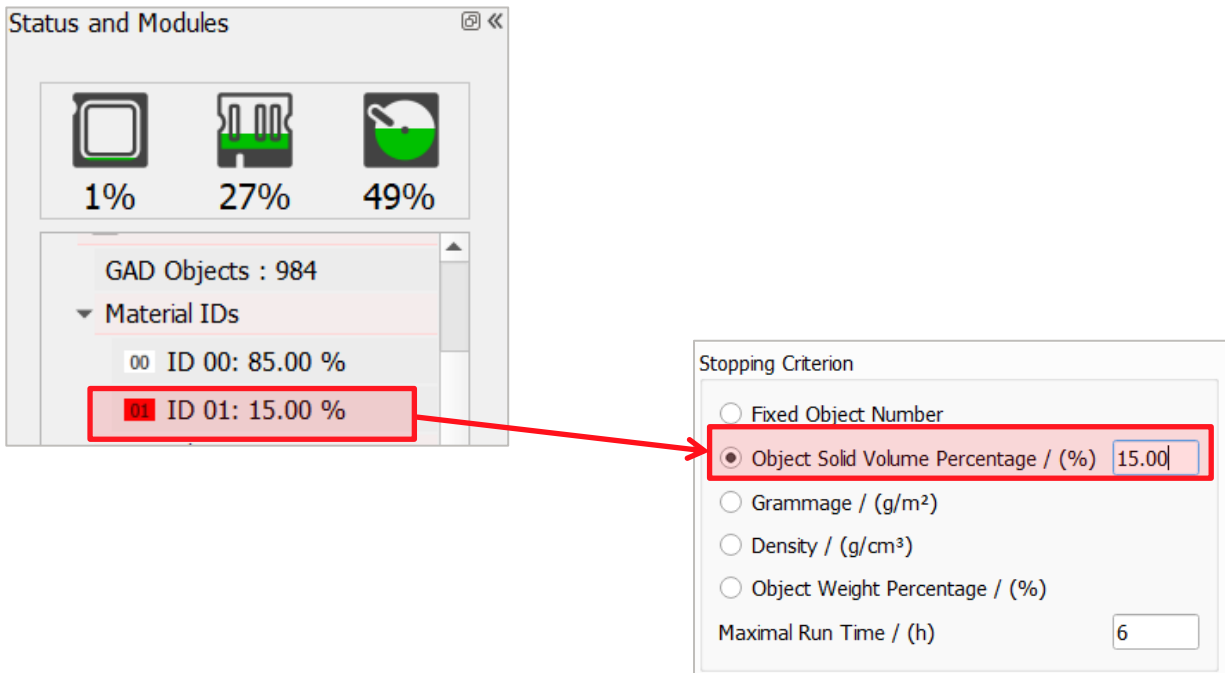

Remember to set the correct domain size (**NX**, **NY**, **NZ**) and **Voxel Length** in the Domain panel.

Click **OK** to close the **FiberGeo Create Options** dialog and click **Generate** in the **FiberGeo** section.

The reproduced fibrous material model is shown in the Visualization area, matching the values estimated by FiberFind for the 3D material model obtained from importing (μ)CT images.

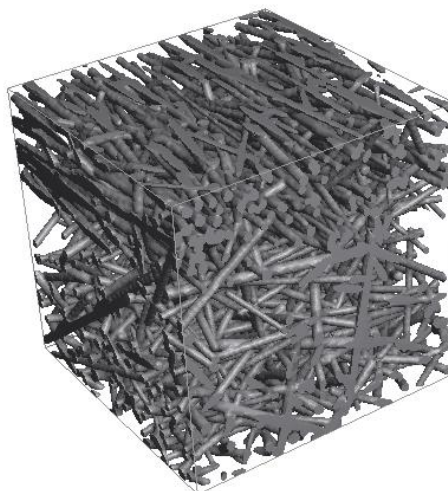

REPRODUCING CURVATURE OF FIBROUS MEDIA

Like the fiber diameter and fiber orientation, it is also possible to create a model of a fiber structure with **FiberGeo**, using the curvature computed in **FiberFind** (see page [26](#)).

For a curved fiber type, like Curved Circular, the Curl Mode **Curvature** can be chosen, and the **Curvature Radius** as well as other parameters can be defined. The Curvature Radius is the inverse of the curvature computed in **FiberFind**. For more details on using this feature, see the [FiberGeo](#) handbook section **Curl Parameters**.

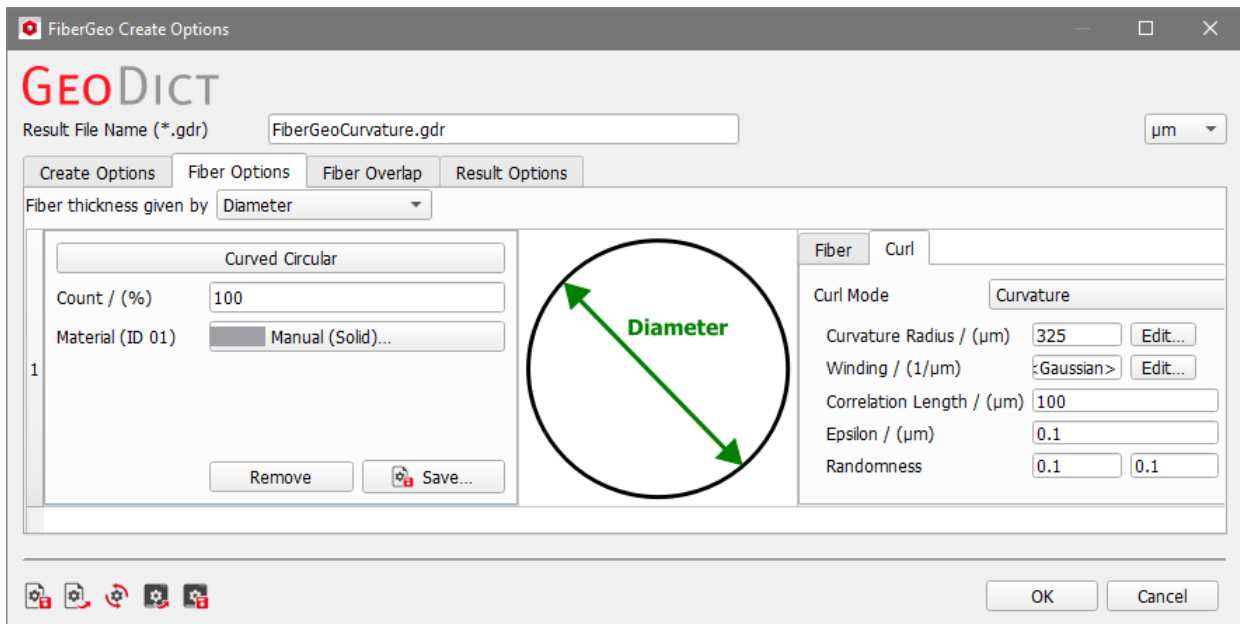

The calculated curvature information (among others) can be used to model a statistical digital twin of the structure. For this, e.g., the **GeoApp Generate Nonwoven Statistical Digital Twin** (under GeoApp → General → Structure Generation) can be used. For more information about GeoApps please refer to the [GeoApps for GeoDict](#) handbook.

IDENTIFY FIBERS (AI)

The final goal of all **FiberFind** tools is to obtain accurate statistical parameters for advanced material design, that can be used e.g., as input data for **FiberGeo**.

There are two distinct approaches for the identification of individual fibers available in **FiberFind**. The first approach uses classical image processing methods, the second one is an Artificial Intelligence (AI) approach. See [Theory – Approaches for fiber identification](#) for more details.

1. The identification of fibers with classical image processing methods is optimized for low density fibrous materials. **FiberFind** identifies fibers by creating a skeleton, that preserves the topology of the fibers. This skeleton is used to determine the center lines of the fibers.
2. The AI approach uses a neural network that has been trained with great amounts of input data. The training data for ground truth is created with **FiberGeo**. Therefore, this approach is capable of identifying individual fibers in a structure, as long as the input data for the training was close enough to the fiber properties in the real 3D-scan.

The start of the computation is a three-dimensional model obtained from segmented computer tomography (or FIB/SEM) scans of the material. Fiber identification provides advanced structure statistics, such as fiber length, number of fibers and better local fiber orientation, as well as object-based image manipulation (for example, changing the diameter of fibers directly from the imported CT-scan images).

As an example for available **FiberFind – Identify Fibers (AI)** options serves a sample of a scan of bulky nonwoven fabric.

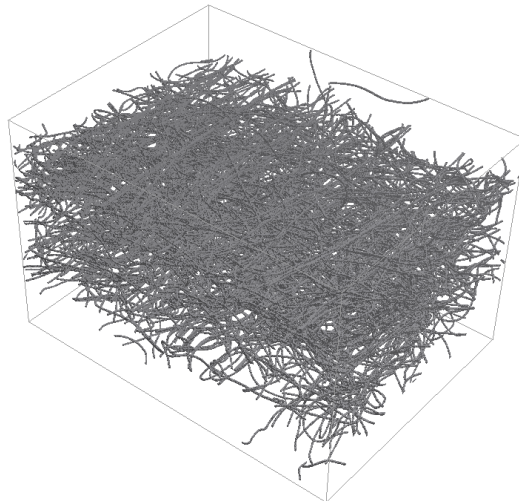

To start, select **Identify Fibers (AI)** from the pull-down menu in the **FiberFind** section. Click the **Options' Edit...** button.

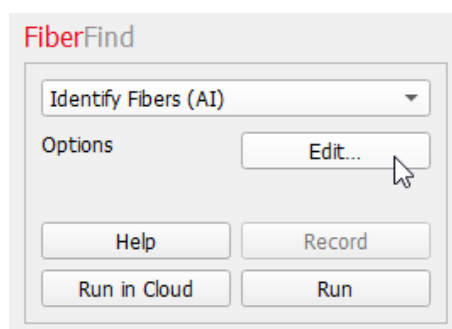

The **Fiber Identification** dialog that opens contains four tabs: **Fiber Identification**, **Solver Options**, **Output Options** and **Equations & References**.

FIBER IDENTIFICATION

First, choose between two **Identification Methods**: **Machine Learning** for the AI approach, or **Analytic** to use the classical image processing approach. Note, that the **Analytic** method is deprecated and will be removed in future **GeoDict** versions.

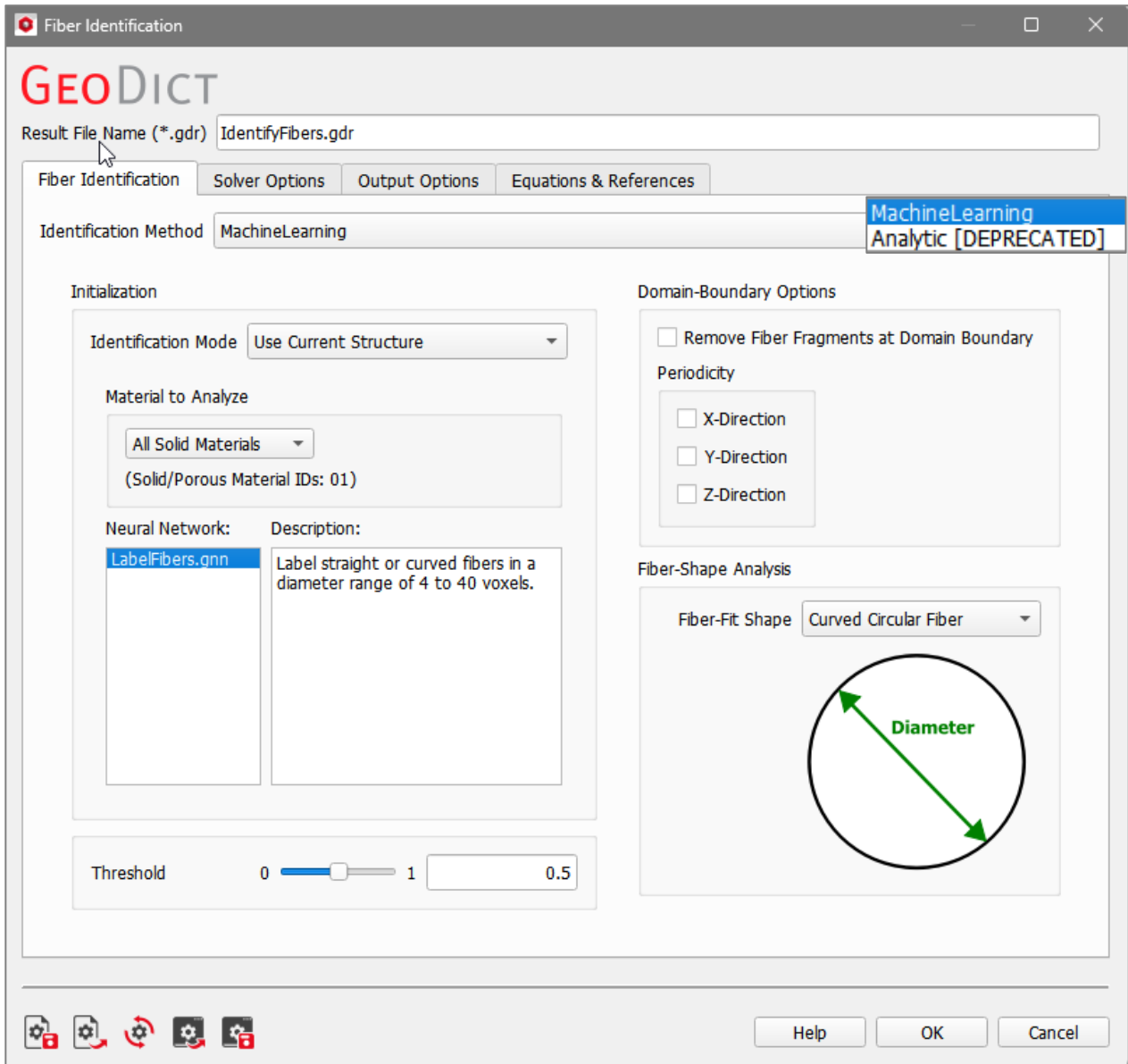

If **Analytic** is selected as **Identification Method**, the **Fiber Identification** dialog changes and then contains the single option to **Do Shape Analysis** only.

Checking **Do Shape Analysis** allows a more detailed analysis of the fiber shape to detect parallel fibers but increases the runtime significantly. If the user does not check **Do Shape Analysis**, the regular analytic fiber identification method is carried out.

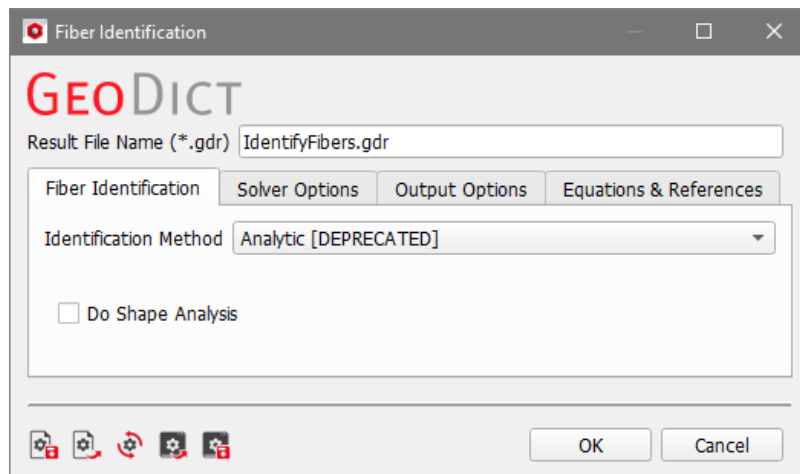

After choosing **Machine Learning** as the **Identification Method**, several options are available in the **Fiber Identification** dialog. However, for most of the application cases, the default values can be kept for most of the options.

Select the neural network listed under **Neural Network** (.gnn stands for **GeoDict neural network**). Besides the latest Neural Network provided with the software (LabelFibers.gnn), Neural Networks trained with **GeoDict-AI** can be used, too. Therefore, the corresponding .gnn-file has to be copied into the installation directory for **Identify Fibers (AI)** (e.g. C:\Program Files\Math2Market GmbH\GeoDict 2024\FiberFind\IdentifyFibers) in order to be selectable in the **Neural Network** field.

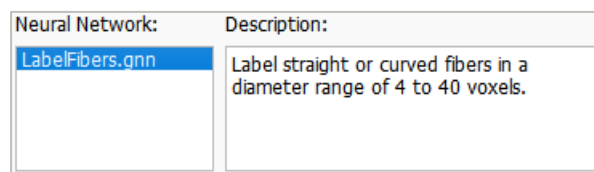

In the **Description** field, the current constraints for the application of the neural network are listed, such as the compatible fiber diameter range.

The **Material to Analyze** panel offers the choice of whether **Identify Fibers (AI)** should be applied to all solid and porous materials in the structure or only on a subset, defined either by choosing material IDs or materials.

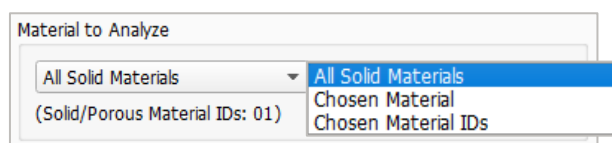

The neural network provides probabilities about whether a solid voxel is a fiber centerline voxel or not. The **Threshold** parameter defines the limit for this labelling and can therefore be defined by the user between 0 and 1 (default 0.5). If the identified fibers are over-segmented, choosing a smaller threshold can lead to better results, see example on page [56](#).

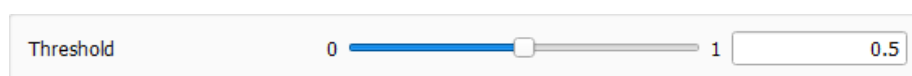

Two choices are available as **Identification Mode: Use Current Structure** and **Load Neural Network Output**.

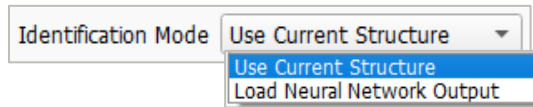

The default **Use Current Structure** should usually not be changed, meaning that **Identify Fibers (AI)** will be applied to the structure that **GeoDict** currently has in memory.

On occasion, the user may want to change the threshold without having to run the identification for each voxel with the neural network again, the option **Load Neural Network Output** may be very useful. Starting with a given Neural Network Output saves calculation time, as the Neural Network probability results can be used before new threshold-based calculations are made.

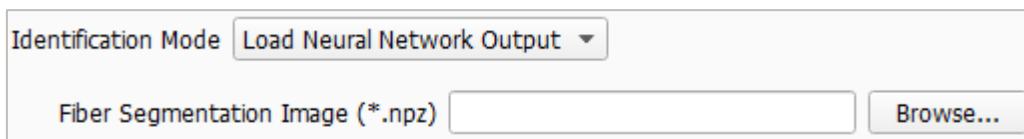

Browse to a **GeoDict** result folder of a previous run of **Identify Fibers (AI)** and select a `nnOutput.npz` file from that folder. Accordingly, the **Material to Analyze** and the **Neural Network** to be used cannot be changed, and the loaded structure needs to be the same.

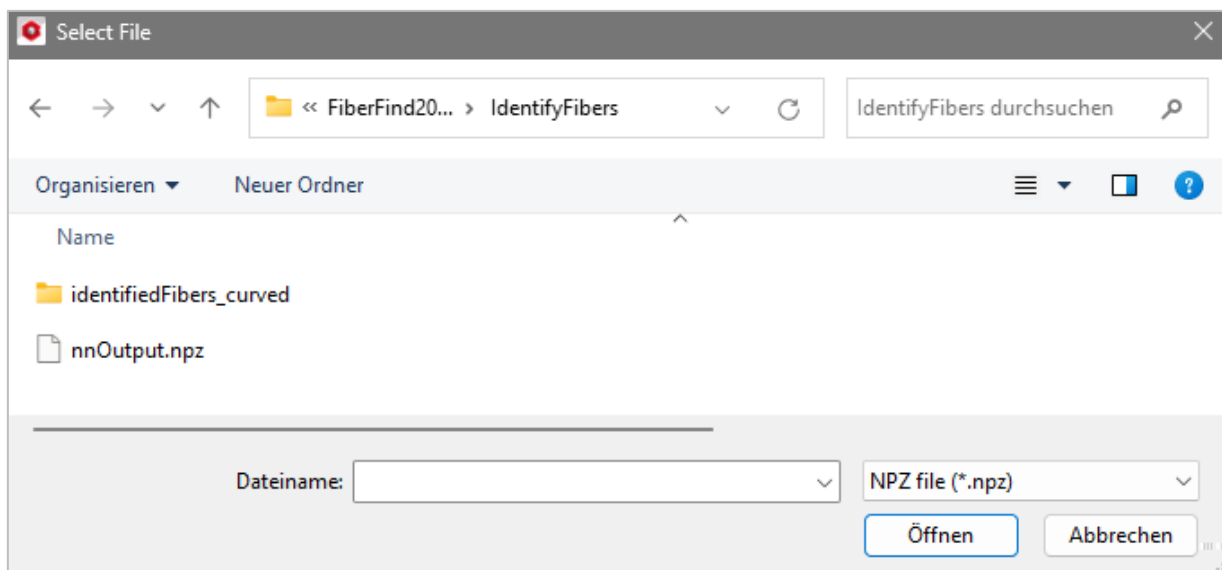

The underlying domain can be set as periodic for the fiber identification by checking one or several of the boxes in the **Domain-Boundary Options** panel. However, periodicity is unusual for most 3D scans and this setting is rarely changed.

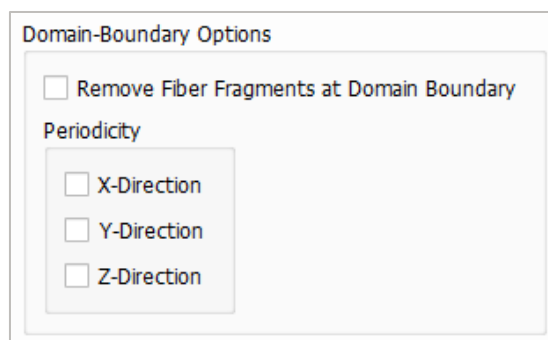

Check the **Remove Fiber Fragments at Domain Boundary** in this panel, to remove all fibers that touch the boundary of the domain after the fiber identification algorithm.

Finally, in the lower right of the **Fiber Identification** dialog, in the **Fiber-Shape Analysis** panel, select the type of fibers in the structure. **Curved Circular Fiber** or **Short Circular Fiber** are available.

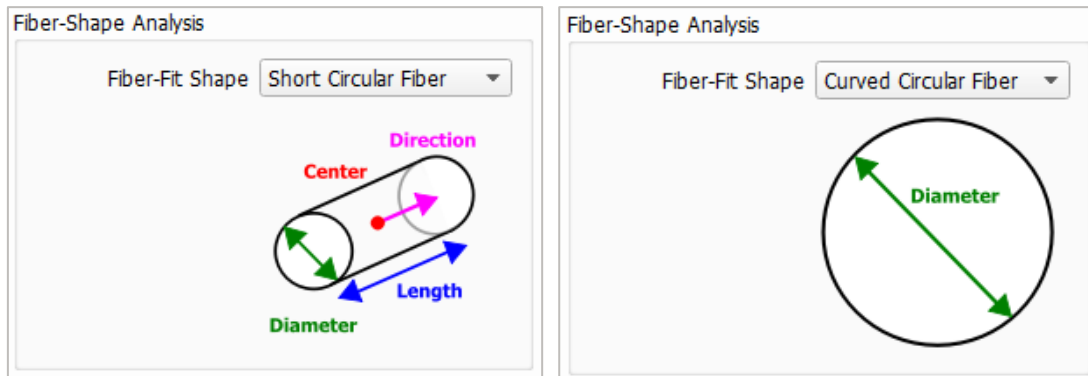

Selecting **Curved Circular Fiber**, FiberFind performs the identification under the assumption that the structure might contain curved fibers.

If **Short Circular Fiber** is chosen, fibers are identified twice: once with the default option of curved fibers and once under the assumption of straight fibers only. For the computation of fiber length distribution and fiber orientation, the result of the curved fiber identification is always used.

SOLVER OPTIONS

Note that this tab is only used, as long as **Machine Learning** is selected from the **Identification Method** pull-down menu under the **Fiber Identification** tab.

If suitable graphics cards are detected during installation of GeoDict, the preferred GPU can be chosen via a checkbox and will be used for running **Identify Fibers (AI)**, otherwise it is running in CPU mode.

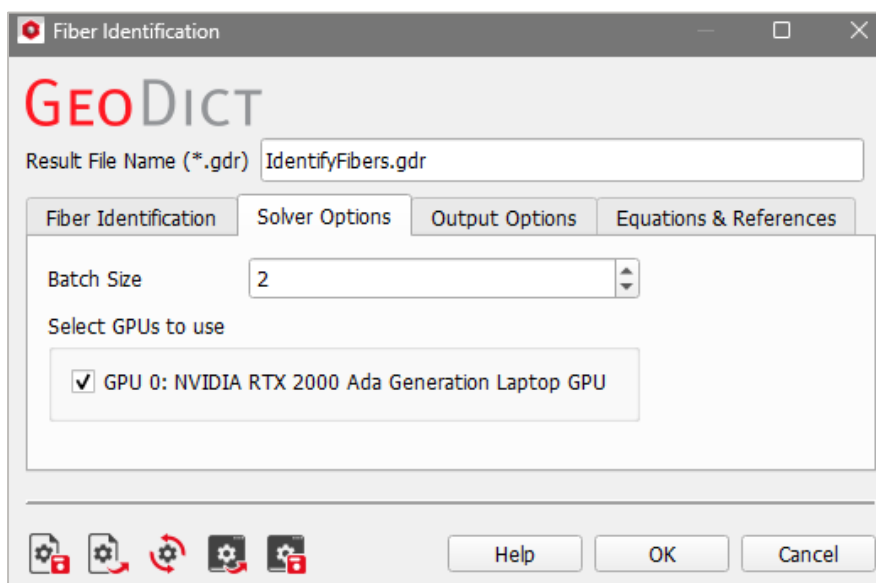

The choice for **Batch Size** is related to the memory available on the graphics card (GPU). Conceptually, FiberFind loads the graphics card with portions of work called **batches**. The higher the number of batches, the faster the computation. Currently,

Identification of binder and fibers, and analysis of fiber properties

the selection must be made manually by entering an appropriate value in the **Batch Size** field.

In case of a Batch Size, which is too large for the available graphics card, the following error message appears.

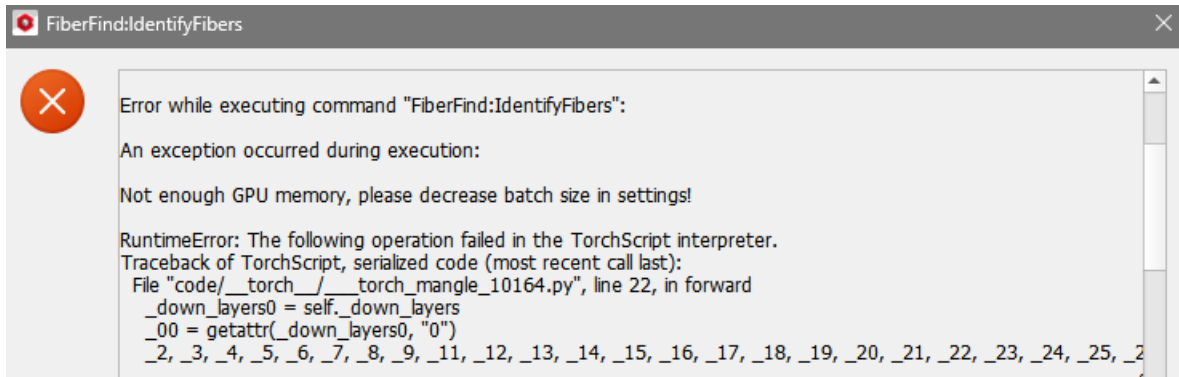

EQUATIONS & REFERENCES

In the **Equations & References** tab recent publications on this topic are listed.

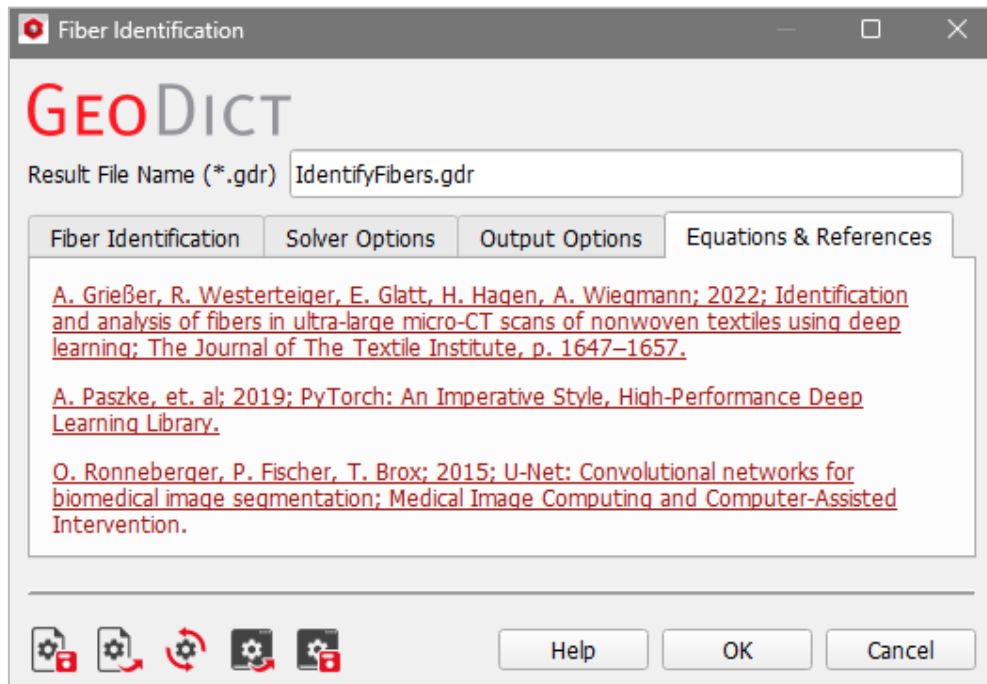

FIBER IDENTIFICATION RESULTS

After running the fiber identification, a folder with the same name as the **GeoDict** result file is saved in the chosen project folder (**File** → **Choose Project Folder...** in the menu bar). This folder contains folders and files needed internally for the calculations. The content of the folder depends on the selected **Identification Method** and parameters. The original structure model on which the identification was done is also saved in the folder.

The **GeoDict** Result Viewer opens for the result file and statistical properties of the identified fibers are shown.

In the Result Viewer, under the **Results - Plots** subtab, the user finds histogram plots of the fiber length distribution and, for **Identification Method Machine Learning**, the distribution of fiber diameter.



On the left panel of the **Results** subtab, the number of bins for all distributions shown in the plots can be selected. Click **Apply** to generate the plots for a different number of bins.

Other options that can be selected in the post-processing panel on the left, are explained below, see page [47](#).

Also available are curvature and orientation information, under the **Results - Plots** subtab plots of the **Fiber Curvature Distribution**, the **Curvature Autocorrelation** and the **Fiber Curl-Index Distribution** as well as three plots showing the fiber orientation as histograms of projections of the fibers to two-dimensional planes can be found.

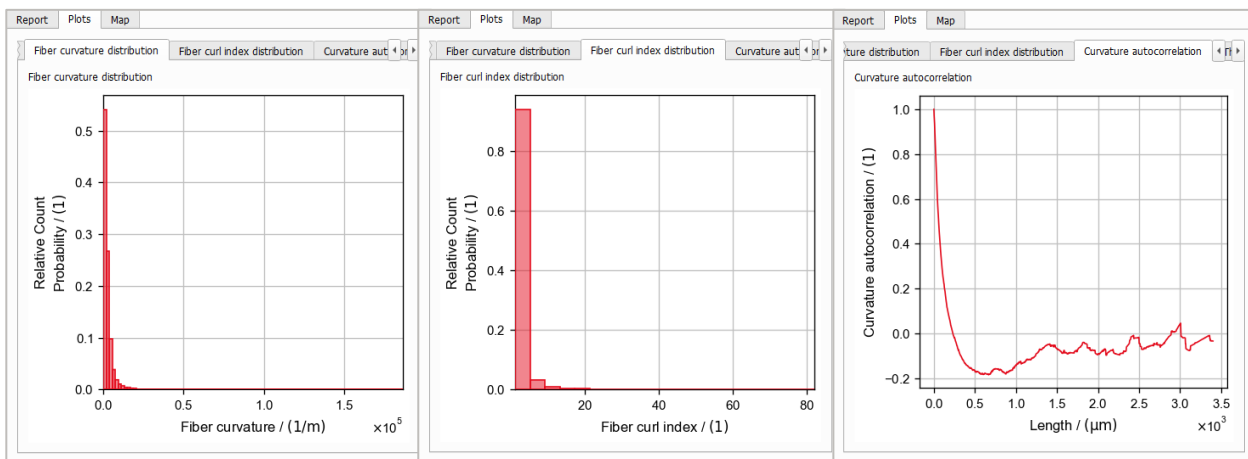

To compute the three orientation histograms, each fiber is projected to the two-dimensional plane. The angle of each fiber segment, weighted with the length of the segment, gives an entry in one bin of the histogram, i.e., in one segment of the circle.

The number of fiber segments for an orientation in the plane is given by the size of a segment of the circle. Since the histograms are normalized, this number is always a value between 0 and 1. The histogram is symmetric since fiber orientations of 0° and 180° are undistinguishable.

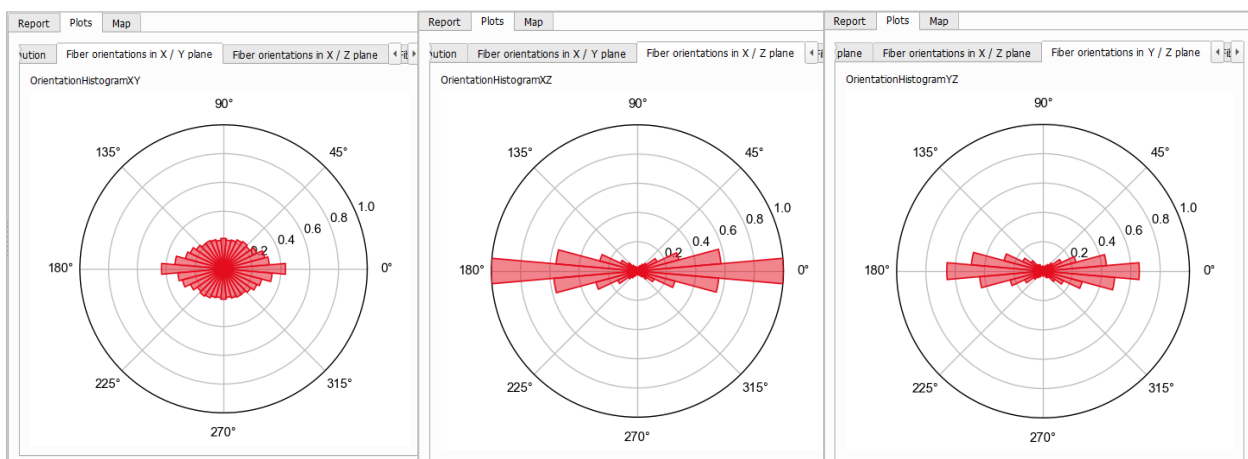

Fibers in this example are oriented mainly in the X/Y plane with a bias in X-direction. Histograms of X/Z plane and Y/Z plane show large segments for 0° and 180°, and segments in Y-direction are even a bit larger. In contrast, the plot of X/Y plane shows a more homogeneous distribution of fibers in this plane, but the preference for X-direction is also visible there.

Besides the bin size for each of the histograms shown, that can be selected by the user, additional post-processing options are available.

In the histograms of fiber length and diameter, the fibers can be classified with respect to many fiber properties.

Fiber Property	Diameter	Length Diameter CurlIndex Curvature CenterOfMassZ AngleToX AngleToY AngleToZ
Number of Bins	100	
Thresholding Method	Otsu	k-Means Otsu Manual
Number of Fiber Types	2	

Select a **Fiber Property** for the classification and define the number of different classes by choosing the **Number of Fiber Types**.

In this example, the fiber diameter distribution (page 46) implies that fibers are of mainly two different diameter classes. To classify the result accordingly choose **Diameter** for **Fiber Property** and the number **2** for **Number of Fiber Types**.

Select a **Thresholding Method** for the differentiation of fibers of different type (**k-Means**, **Otsu's method** or define a **Manual** threshold) and the **Number of Bins** used for the separation of fibers.

Here, 100 bins are used to separate the fibers according to the Otsu's method. Click **Apply** to change the **Fiber length distribution** histogram and, if available, the **Fiber diameter distribution** histogram. These histograms are shown now as stacked values for both fiber types.

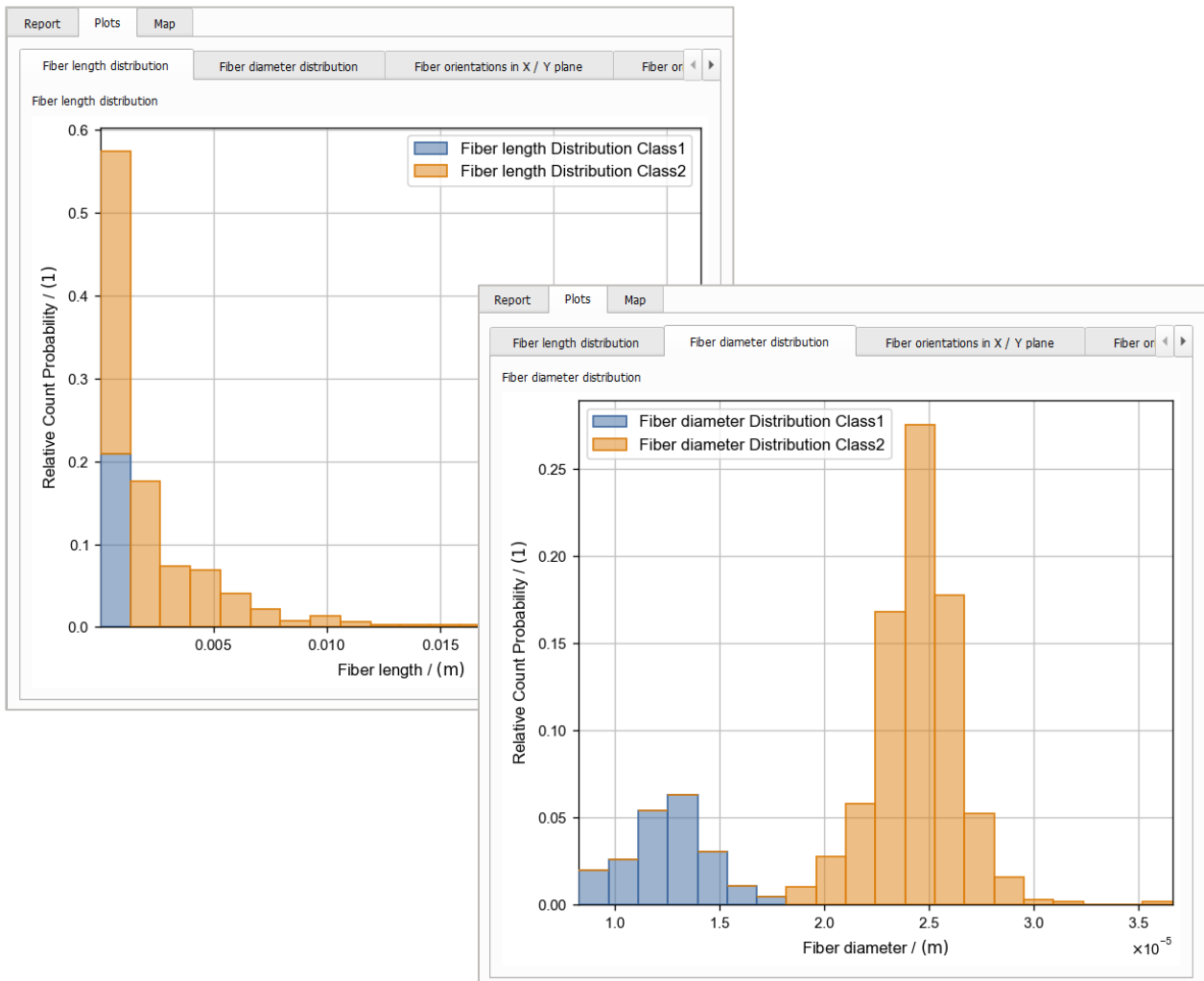

An additional tab (**Threshold by scalar value**), containing the fiber diameter distribution with the number of bins defined for the thresholding, the resulting threshold(s) for the selected method and a Gaussian fit for both fiber types, is created.

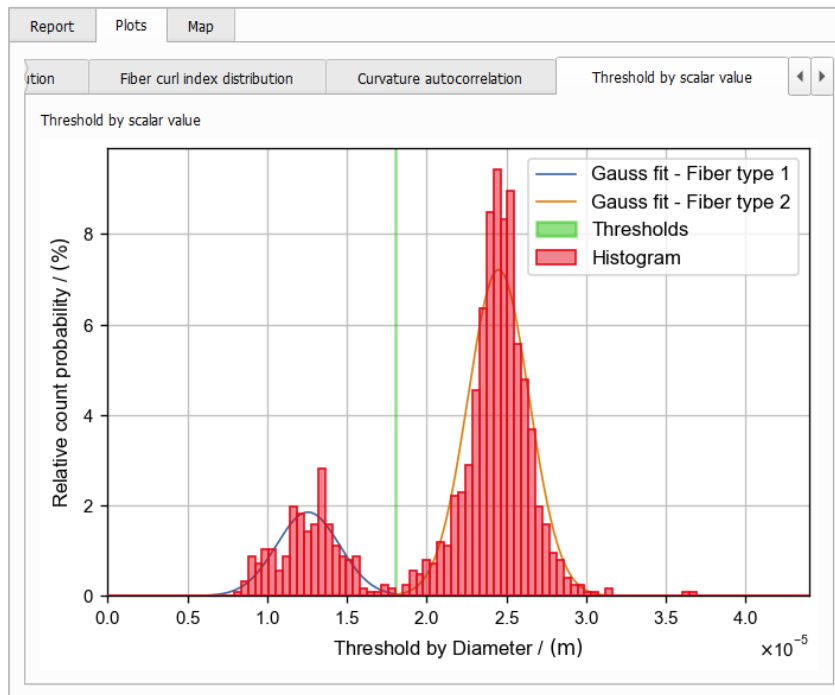

Note that the threshold (the green vertical line in this example) changes for different Thresholding Methods or can directly be defined by the User after choosing **Thresholding Method – Manual**.

The classification of fibers is also included in the Results Report, see page 50.

The structure with the separated fiber types, can be loaded to the Visualization Area under the **Fiber Identification Visualization** tab, see page 52.

To create an additional tab, showing the layered values in z-direction for a fiber property, select a **Layered Fiber Property** from the pull-down menu. With **Layered Fiber Property Weighting** define if the mean in each layer is computed with respect to the number, the volume or the length of the fibers.

Click **Apply**.

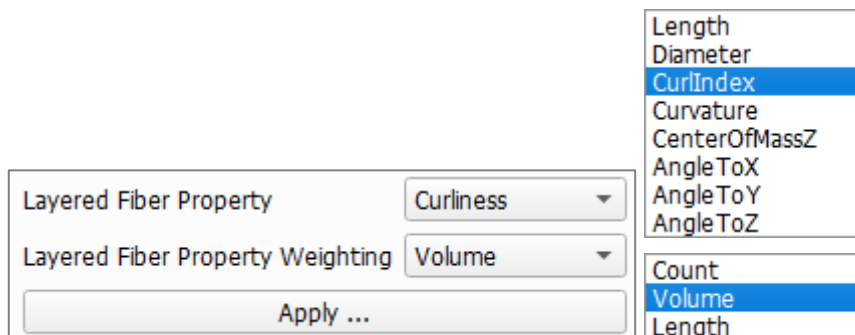

A new tab for the layered distribution is added to the **Plots** subtab, according to the values selected.

For the example shown here, the tab **Layered fiber curl index distribution** is created, showing the mean fiber curl-index (weighted with respect to the fiber volume) for each layer in z-direction of the structure.

Note that the visualization of layered fiber properties in z-direction is only possible for **Identification Method Machine Learning**.

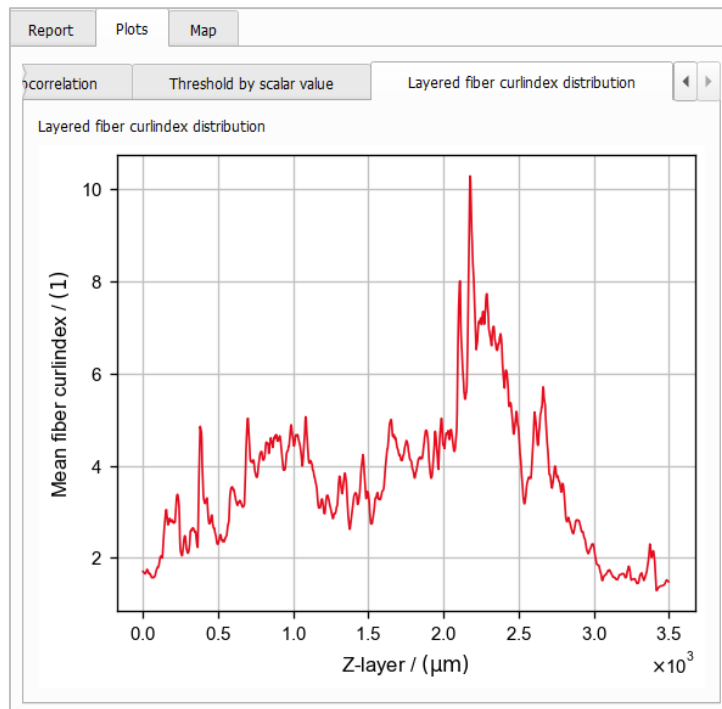

Click on **Plot Options** and select one of the histograms available, to access directly the dialog boxes for changing the Axis Settings or Graph Styles. These dialogs can be accessed as well by a right mouse-click in the histogram.

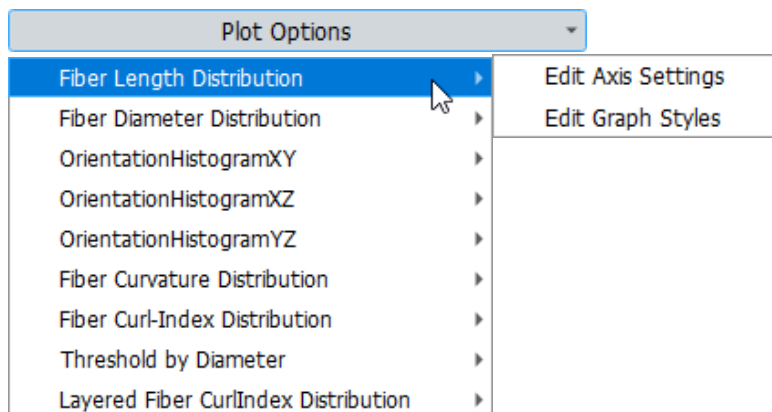

For more details on modifying plot settings, see the [Result Viewer](#) handbook.

The torsion of the fibers as well as the torsion autocorrelation are available in the **GeoDict** result file (*.gdr), but currently not on the **Plots** subtab. They are shown on the **Results-Map** subtab, and can be found in the *.gdr file under the keys *DerivedResults:Torsions*, for the torsion of each identified fiber segment, *DerivedResults:MeanTorsions*, for the mean torsion of each identified fiber and *DerivedResults:TorsionAutocorrelation* for the autocorrelation function of the torsion values.

The information about fiber orientation, fiber length distribution, fiber diameter distribution, fiber curvature distribution and fiber curl-index distribution is also available in tables under the **Results - Report** sub-tab.

In this report, first the total number of identified fibers is shown. Here 1274.

Key	Unit	Value
CoreResults		
NumberOfFibers		1274
MaterialID		2
DerivedResults		
FiberLengths	m	0.0007581399887, 0.0004678936732, 0.0019...
FiberDiameters	m	2.697383118e-05, 2.351415431e-05, 2.37297...
MeanCurvatures	1/m	1758.132769, 2761.060315, 2274.961742, 42...
CurlIndexValues		1.038918489, 1.063133079, 1.48462046, 6.4...
FiberAnglesToX	Deg	81.37744281, 35.66760291, 37.83609155, 56...
FiberAnglesToY	Deg	33.69777158, 65.79378063, 72.71726419, 48...
FiberAnglesToZ	Deg	58.70212809, 69.18986423, 61.5448646, 67....
MeanTorsions	1	0.1222681637, -0.07100059048, 0.05813754...
Curvatures	1/m	1755.903037, 1755.903037, 1755.903037, 17...
Torsions	1	0.3181359114, 0.3181359114, 0.3181359114...
CurvatureAutocorrelation		1, 0.9725138916, 0.9568992896, 0.93692437...
TorsionAutocorrelation		1, 0.9080634574, 0.893911455, 0.876121113...
BoundaryContacts		2, 2, 2, 2, 2, 2, 2, 2, 2, 2, 2, 2, 2, 2, 2,...
OrientationTensor		0.4970645773, 0.4062961055, 0.0966393171...
Anisotropy1		3.636530926
Anisotropy2		0.8284817238
Phi	Deg	-156.7126588
Theta	Deg	1.585829334
Psi	Deg	157.7210978
Diameter		
Length		
CurlIndex		
Torsion		

Next, a table shows the number of fibers, the mean diameter, mean length, mean curvature, mean curl-index and mean torsion and the orientation for each fiber type, defined via the **Threshold by Fiber Property**, see page 57.

The screenshot shows the 'Result Viewer' window with the following settings and results:

- Domain Size: 1500 x 2000 x 1296, Voxel Length: 2.7 μm
- Input Map: 20 bins for Fiber Length Distribution, 20 bins for Fiber Diameter Distribution, 18 bins for Orientation Distribution, 100 bins for Curvature Distribution, 20 bins for Curl-Index Distribution.
- Threshold by Fiber Property: Fiber Property: Diameter, Number of Bins: 100, Thresholding Method: Otsu, Number of Fiber Types: 2.
- Layered Fiber Property: CurlIndex, Layered Fiber Property Weighting: Volume.
- Back-up result file:

FiberFind Results:

Found 1274 individual fibers in the structure.

Fiber properties segmented by Diameter:

Property	Class1	Class2
Number of fibers	266	1008
Diameter	12.5574 μm	24.5014 μm
Length	85.6375 μm	2.59967 mm
Curvature	0.0209785 1/μm	0.00321565 1/μm
Curl-Index	1.26449	2.40999

Orientation tensor for Class 1:

0.3593	0.0089	-0.0026
-	0.4311	-0.0075
-	-	0.2095

Orientation tensor for Class 2:

0.5009	0.0015	0.0045
-	0.4056	-0.0079
-	-	0.0935

Orientation tensor for all fibers:

0.4971	0.0017	0.0043
-	0.4063	-0.0079
-	-	0.0966

Summary statistics for all fibers:

- Anisotropy 1: 3.637, Anisotropy 2: 0.828
- Euler angles (Phi, Theta, Psi): -156.713, 1.586, 157.721

The fiber type specific information is followed by the values for all fibers. First, the orientation of all fibers is reported.

Since most of the fibers in the example are oriented in X/Y plane, the diagonal entries of the orientation tensor for X-direction (0.4971) and Y-direction (0.4063) are larger than for Z-direction (0.0966). The value for X is higher than the one for Y, showing again the dominance of X- over Y-direction.

The anisotropy values, together with the Euler angles, are another representation of the orientation tensor.

Both representations of the orientation tensor can be used directly in **FiberGeo** to create a structure with the same properties than the structure analyzed (see [Reproducing fibrous media using FiberFind and FiberGeo](#)).

Next, in the **Report**, the mean value and the standard deviation for fiber length and fiber diameter and the mean values for fiber curvature and fiber curl-index are shown, followed by tables with the histogram values of the **Plots** subtabs.

Note that for the mean values of fiber curvature shown here, a mean over all curvature values of all fibers is computed. In contrast to this, the mean curvature of each fiber class is obtained by computing first the mean curvature of each fiber of the fiber class individually and then taking the mean over all these values.

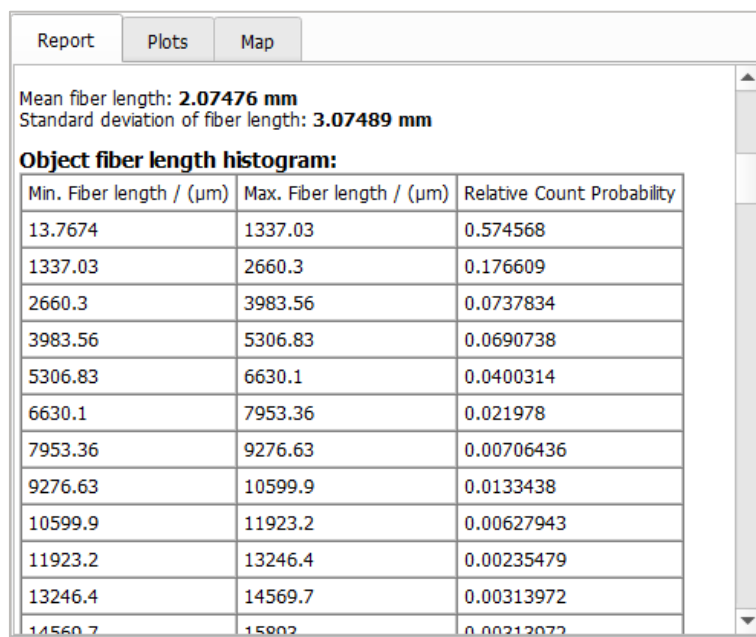

The screenshot shows a software interface with three tabs: 'Report', 'Plots', and 'Map'. The 'Report' tab is active and displays the following information:

Mean fiber length: **2.07476 mm**
Standard deviation of fiber length: **3.07489 mm**

Object fiber length histogram:

Min. Fiber length / (μm)	Max. Fiber length / (μm)	Relative Count Probability
13.7674	1337.03	0.574568
1337.03	2660.3	0.176609
2660.3	3983.56	0.0737834
3983.56	5306.83	0.0690738
5306.83	6630.1	0.0400314
6630.1	7953.36	0.021978
7953.36	9276.63	0.00706436
9276.63	10599.9	0.0133438
10599.9	11923.2	0.00627943
11923.2	13246.4	0.00235479
13246.4	14569.7	0.00313972
14569.7	15892	0.00212022

On the **Fiber Identification Visualization** tab next to the Results tab, several possibilities of visualizing the results are listed. If **Identification Method** was set to **Analytic** (see page [40](#)) only the .gad file with the curved fiber fit and the segmented analytic fibers are available for visualization.

To visualize the fibers identified by the algorithm, click **Load *.g32** in the **GeoDict** Result Viewer under the **Fiber Identification Visualization** tab.

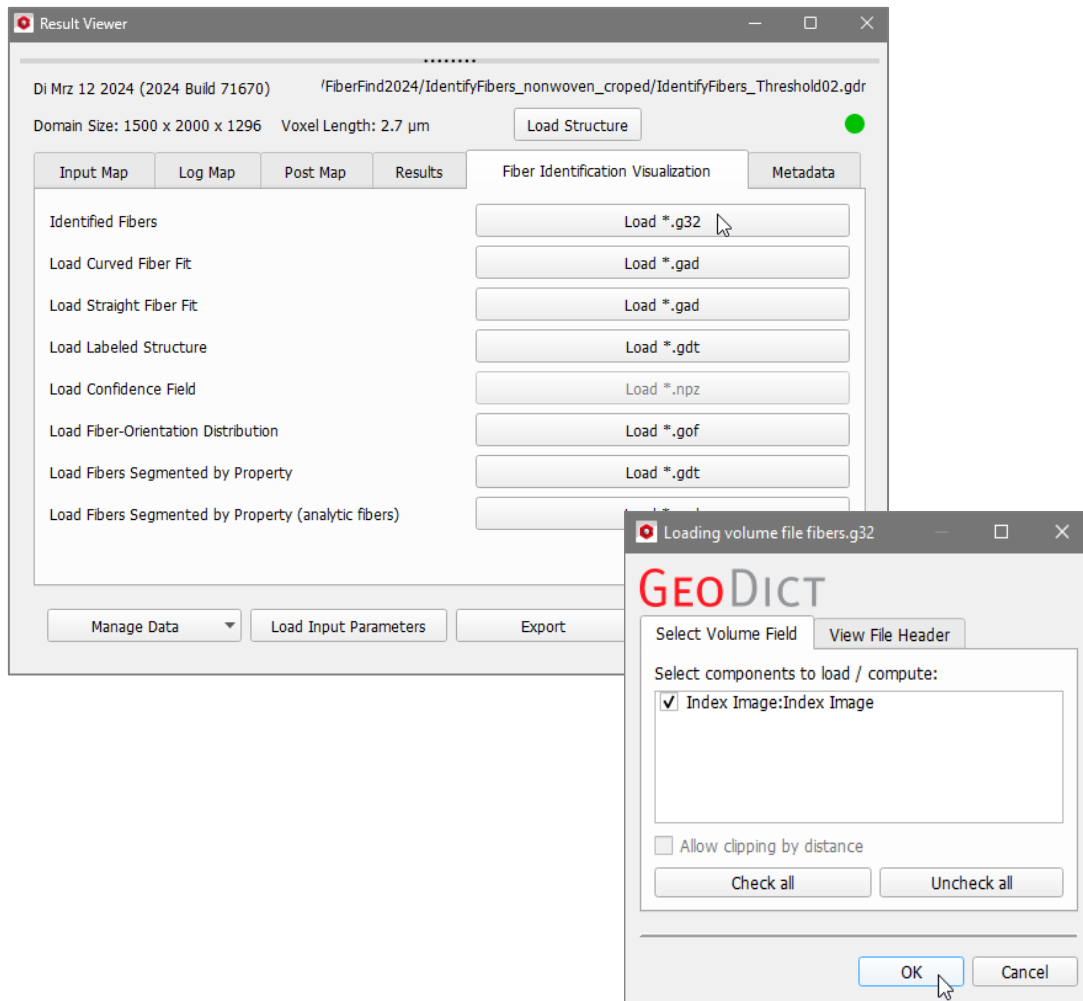

Set the structure to invisible, to see only the identified fibers, by clicking **Yes** in the opening dialog.

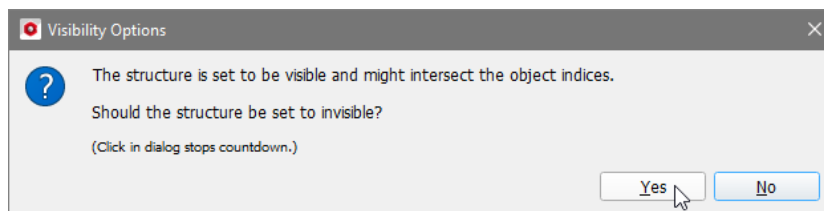

The identified fibers are shown in a variety of colors.

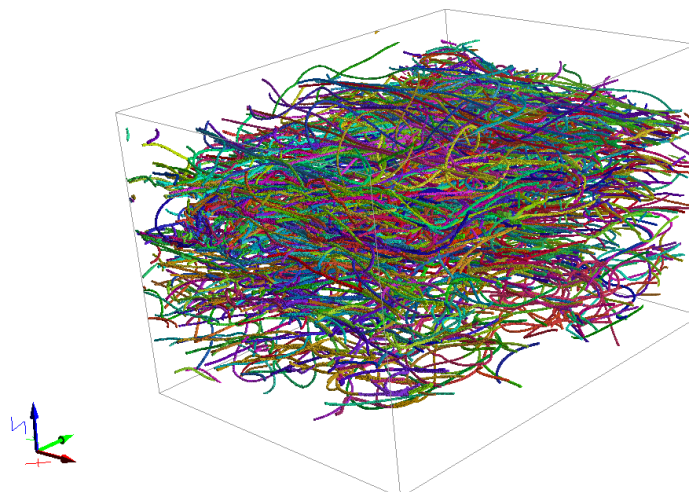

Identification of binder and fibers, and analysis of fiber properties

In the same way, the curved fiber fit (and the straight fiber fit if **Short Circular Fiber** was selected in the **Fiber-Shape Analysis** panel of the **Identify Fibers (AI)** options) can be loaded by clicking on their **Load *.gad** buttons under the **Fiber Identification Visualization** tab. In the loaded .gad files, fibers are contained as analytical objects, with information about fiber diameter, etc. After the identification of fibers, the analytic information contained in the .gad files can be used for modifications of the structure model or further calculations that require fiber analytic data.

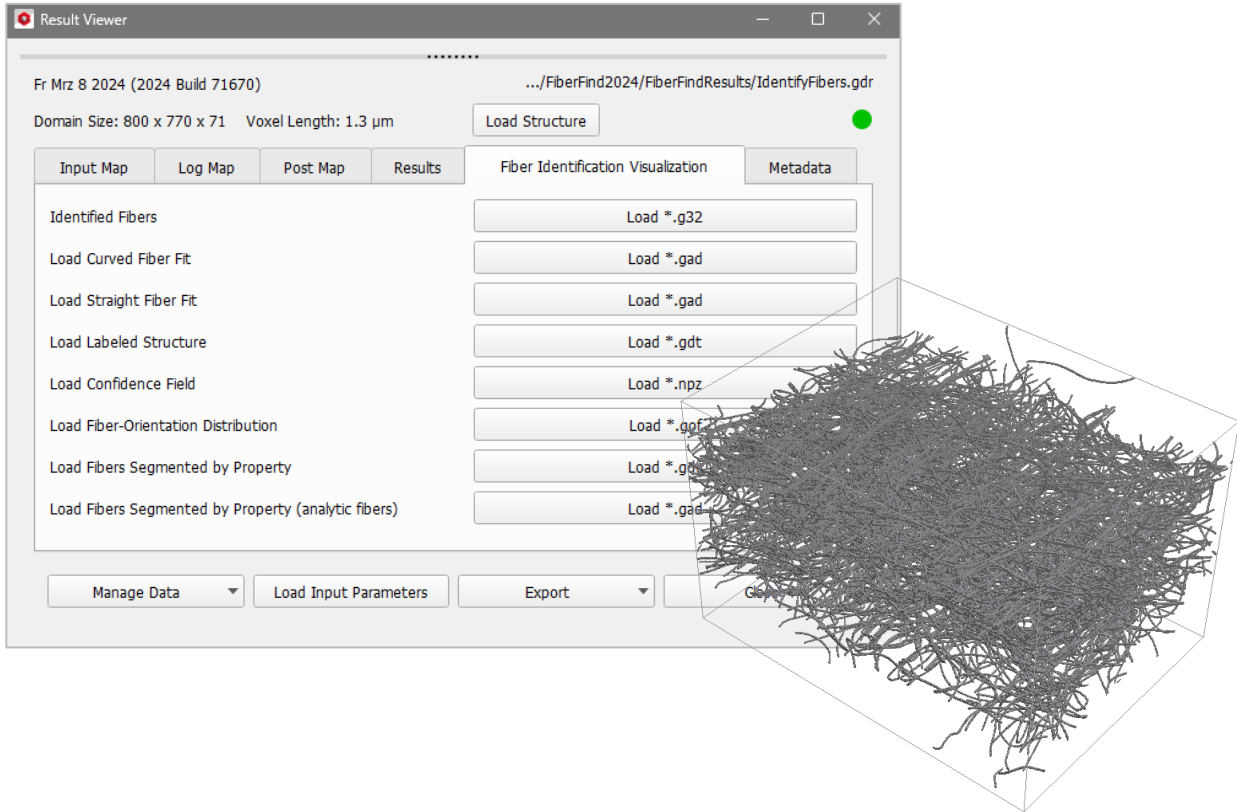

Clicking the (Load labeled structure) **Load *.gdt** button under the **Fiber Identification Visualization** tab, loads the fibers together with the identified centerlines.

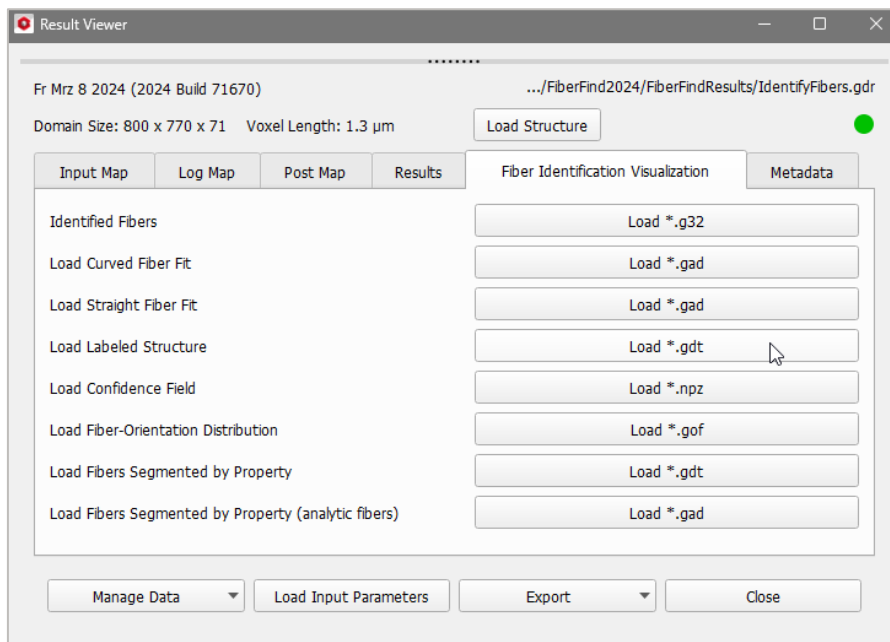

Visualize the loaded labeled structure with the centerlines in 2D (**View** → **2D Cross section** in the menu bar).

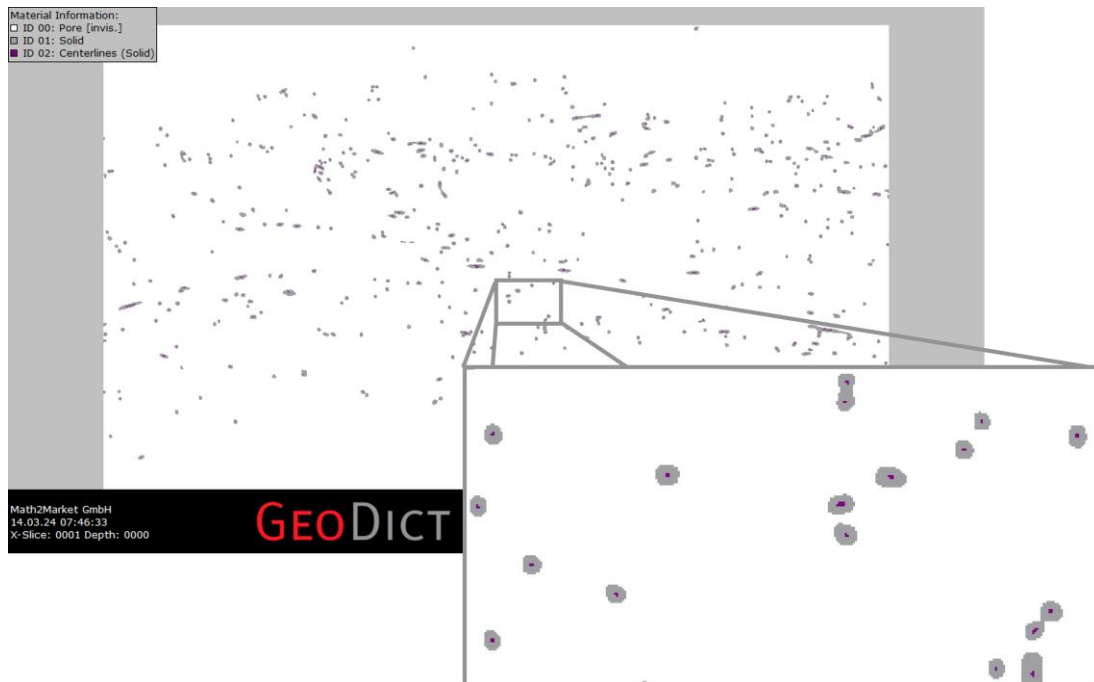

If the centerlines are fragmented, the user might want to re-run **FiberFind – Identify Fibers (AI)** with a lower threshold. If the centerlines appear too thick, a higher threshold value might be beneficial. In order to visualize how the threshold affects the result interactively, perform the following steps.

Click the (Load Confidence Field) **Load *.npz** button to load the unsegmented data of the fiber identification.

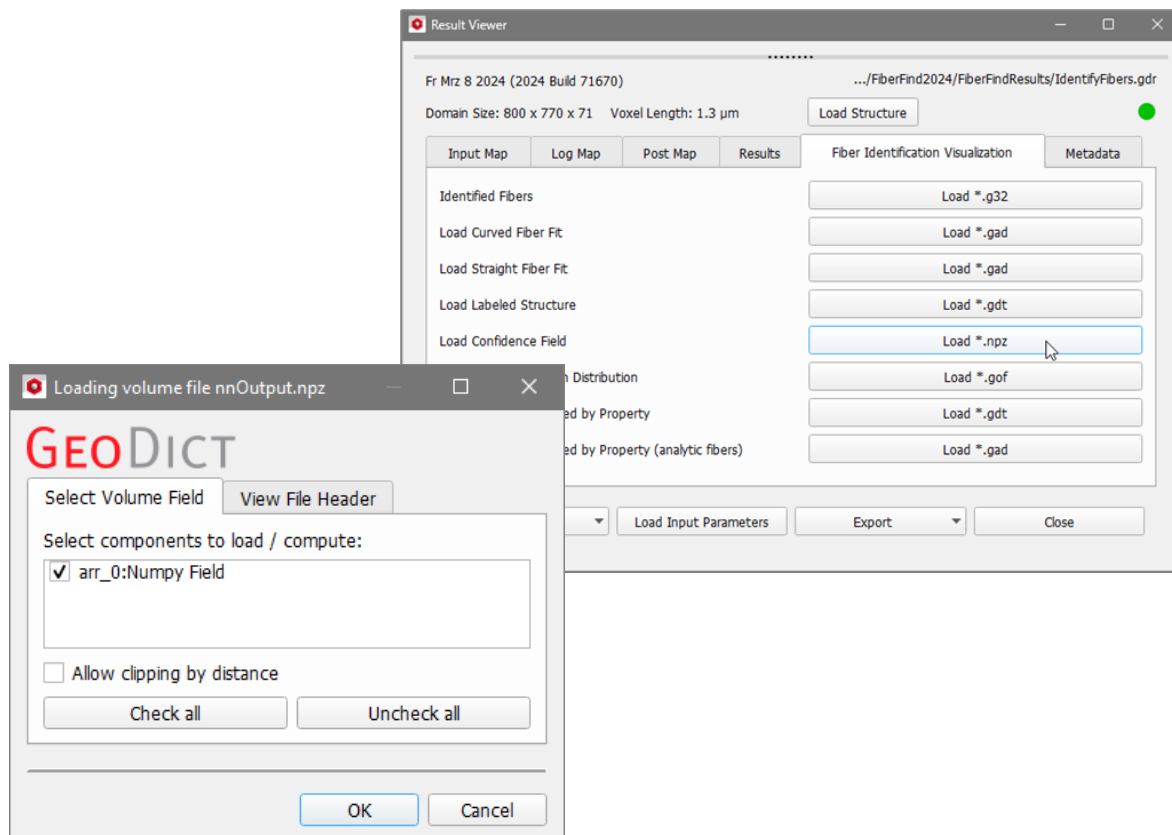

Identification of binder and fibers, and analysis of fiber properties

Set the structure to invisible, by unchecking the **Structure** tab in the Visualization panel, above the Visualization area of the GUI.

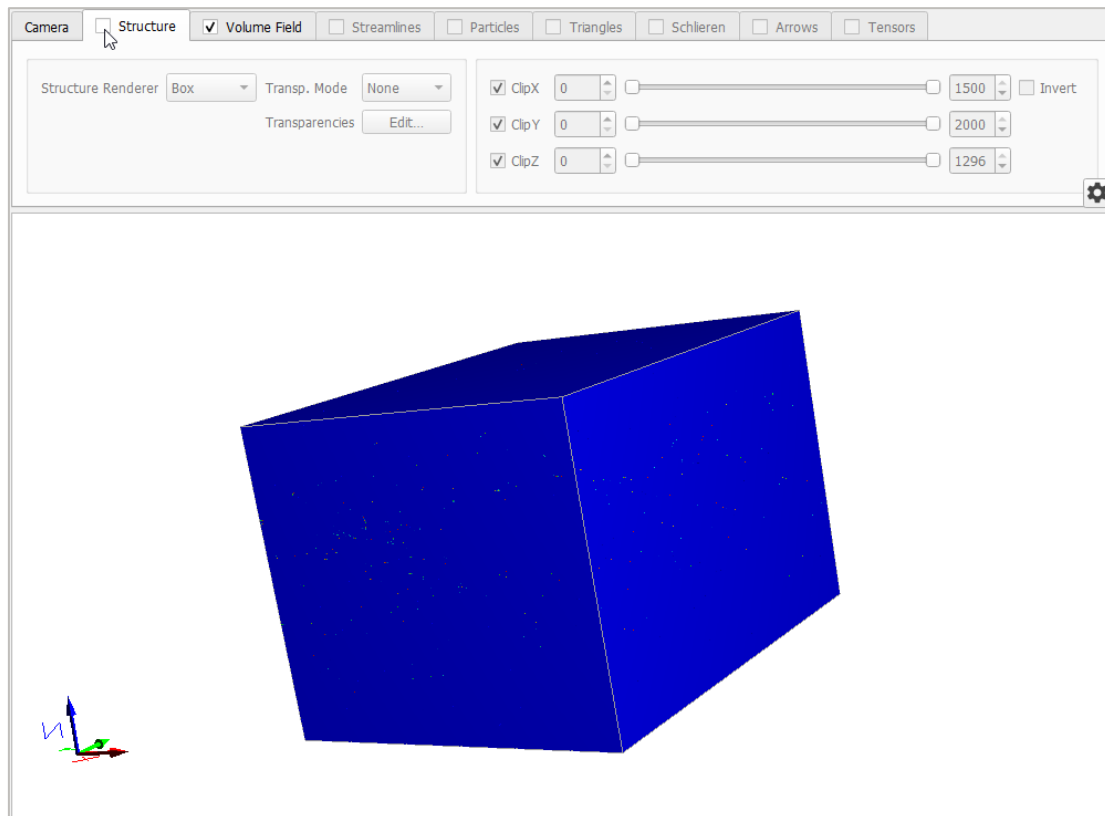

Show the result only for the fibers, by deselecting the material with ID 0 in the **Visibility** pull-down menu of the **Volume Field** tab.

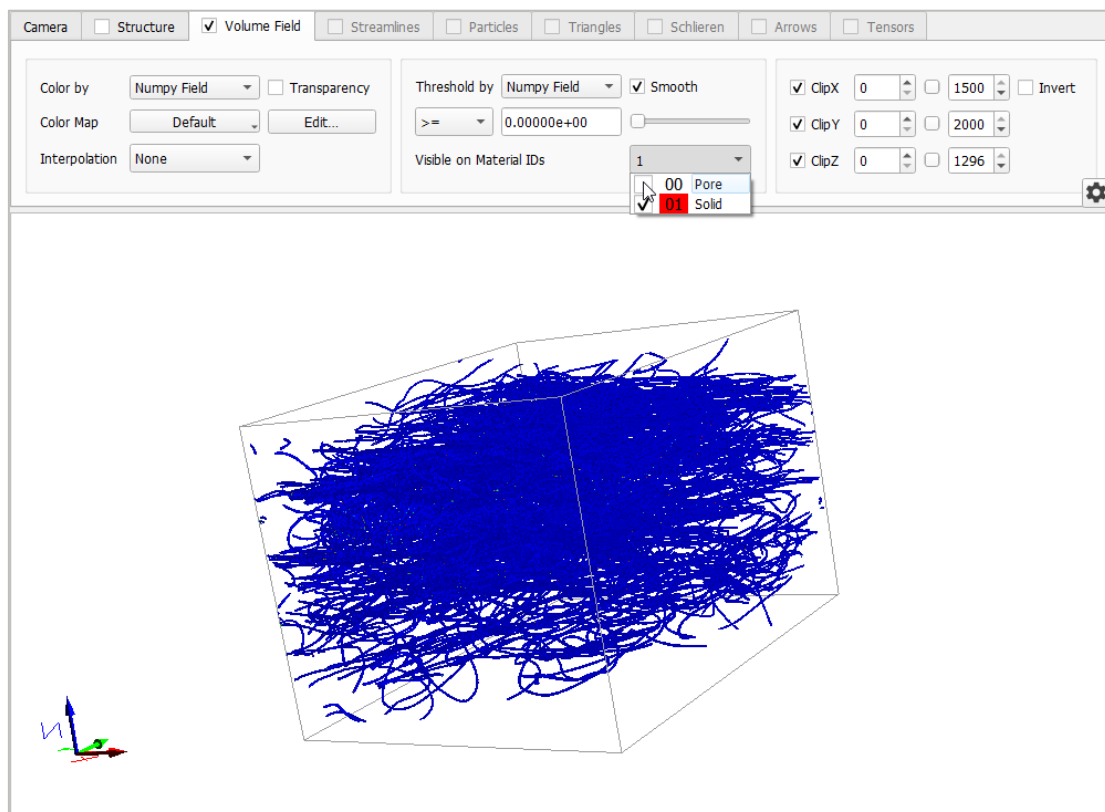

The **Threshold** parameter defines the limit probability value for the decision whether a voxel is a centerline voxel or not. Select **>=** as **Clip Mode** to see the voxels that are identified for separate fibers if this value were to be set as Threshold for the fiber identification (see page [41](#)).

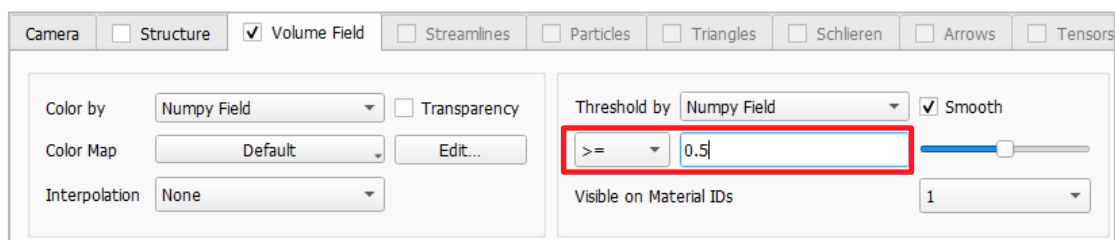

The goal is to find a **threshold** which does not result in fragmented centerlines but also does not fuse the centerlines of neighboring fibers. For this example a default threshold value of 0.5 would lead to a strong fragmentation of fibers as many voxels are not identified to be the centerline of a fiber and thus the fiber itself is subdivided into multiple parts. The representation of identified fibers with threshold 0.5 in the **Volume Field** tab implies that the fibers are too thin (left side of the following figure).

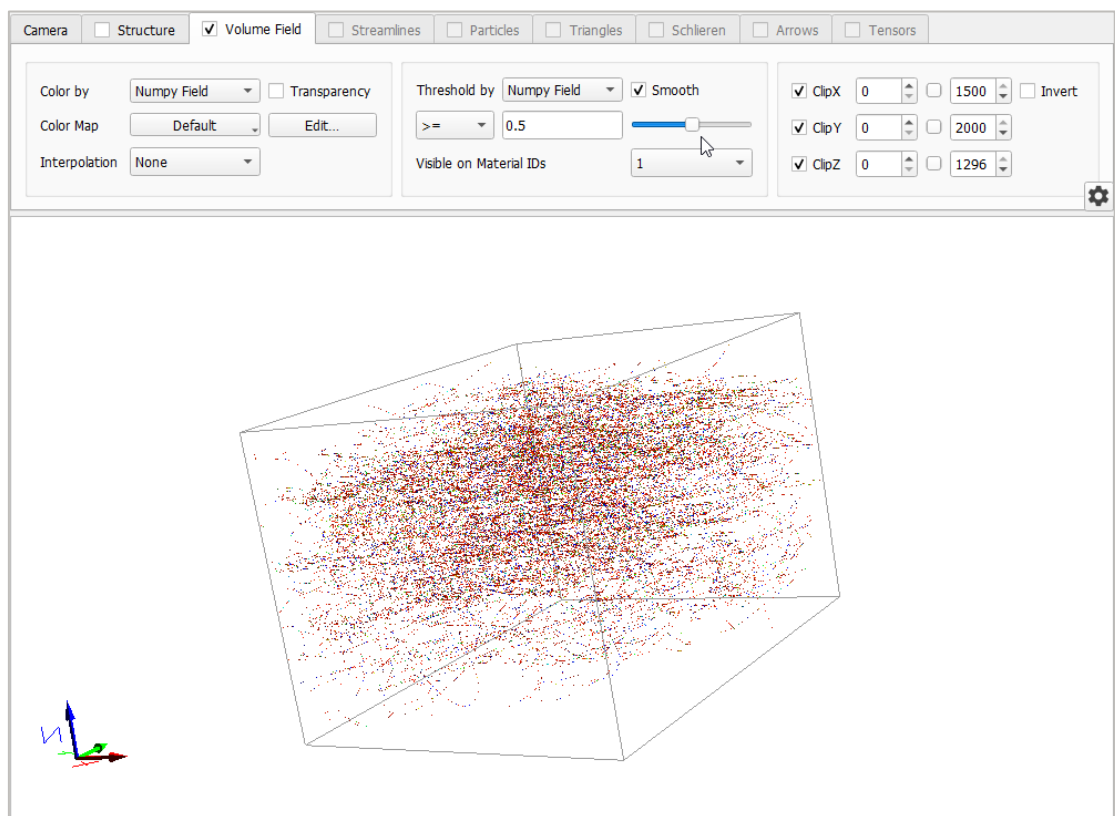

A threshold of 0.2 in turn seem to be a more appropriate value for this example, as seen below.

Taking this observation into account an Identify Fibers (AI) run can be done by setting the threshold to 0.2 and, if an identification result is available already, using the neural network output nnOutput.npz in order to save computation time, see page [42](#).

Identification of binder and fibers, and analysis of fiber properties

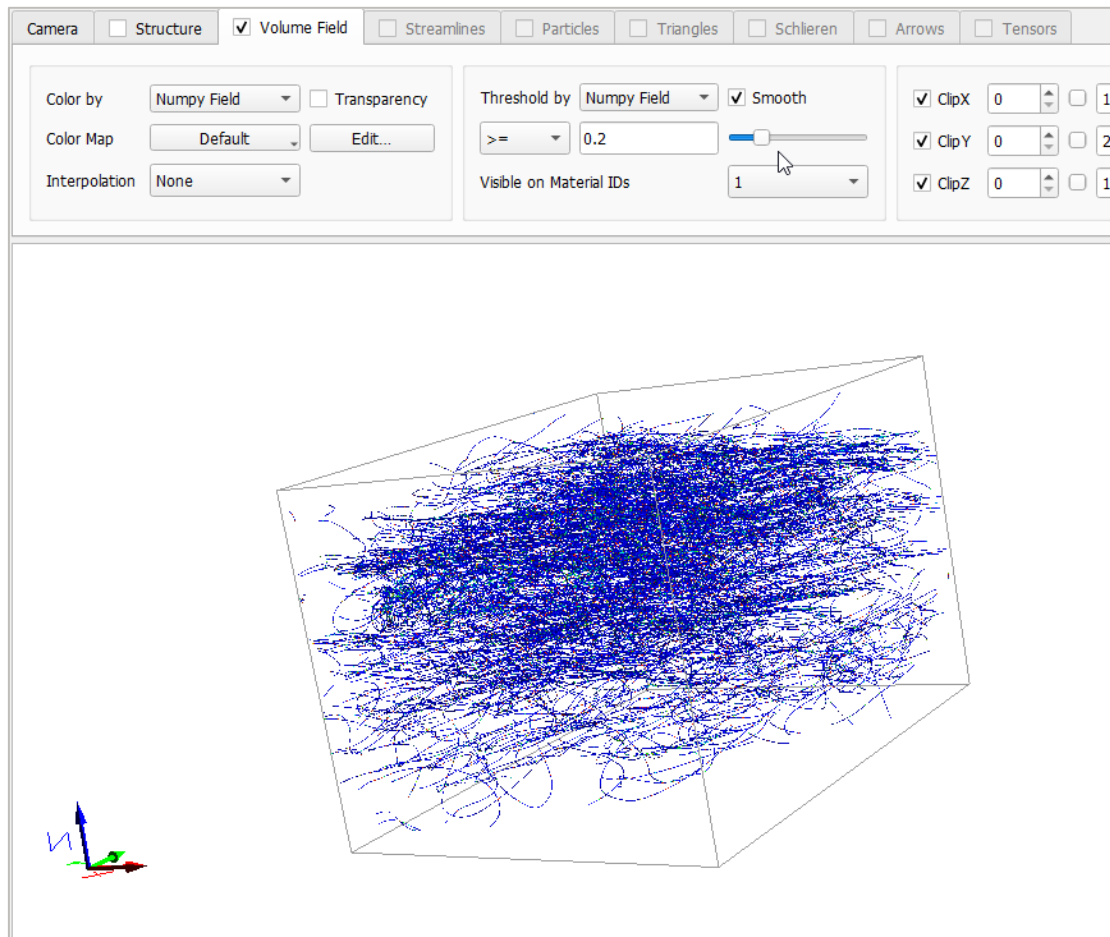

Select the (Load Fiber-Orientation Distribution) **Load *.gof** button to load information about the fiber orientation.

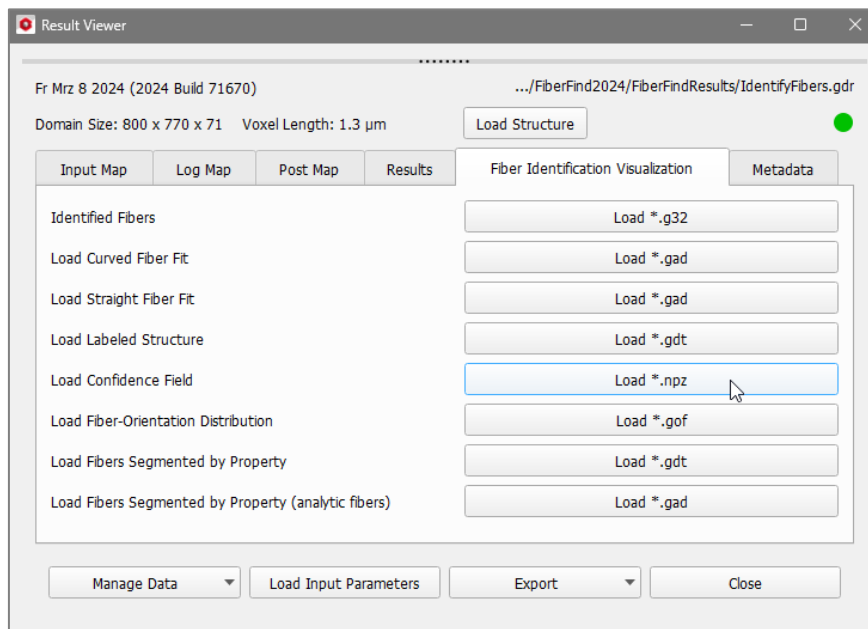

Select e.g. Orientation:AngleToZ to get a visualization of the angle with respect to the z-axis for each identified fiber segment.

This option is available only if **Save Fiber-Orientation Distribution as .gof** was selected on the Output Options tab, see page [44](#).

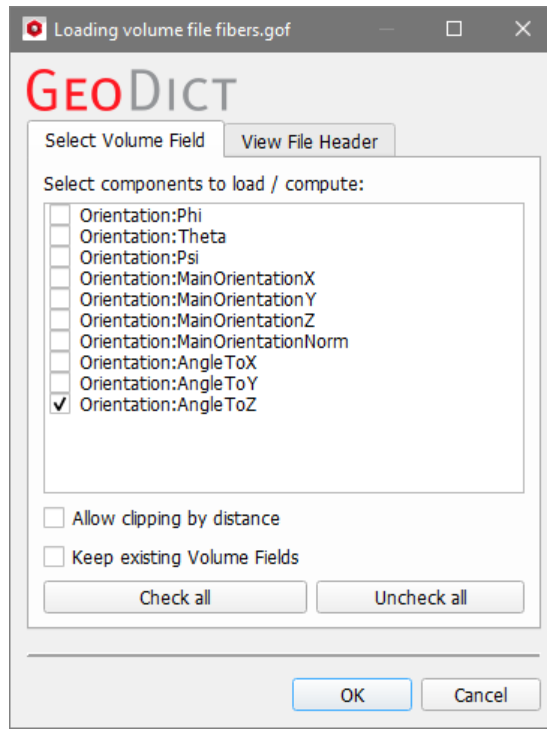

Again, set the structure to invisible by unchecking the **Structure** tab in the Visualization panel, above the Visualization area of the GUI. Show the result only for the fibers by deselecting the material with ID 0 in the **Visibility** pull-down menu of the **Volume Field** tab.

Since in the example shown here, fibers are oriented mainly in x- and y-direction, the angle to the z-axis is high for most of the segments.

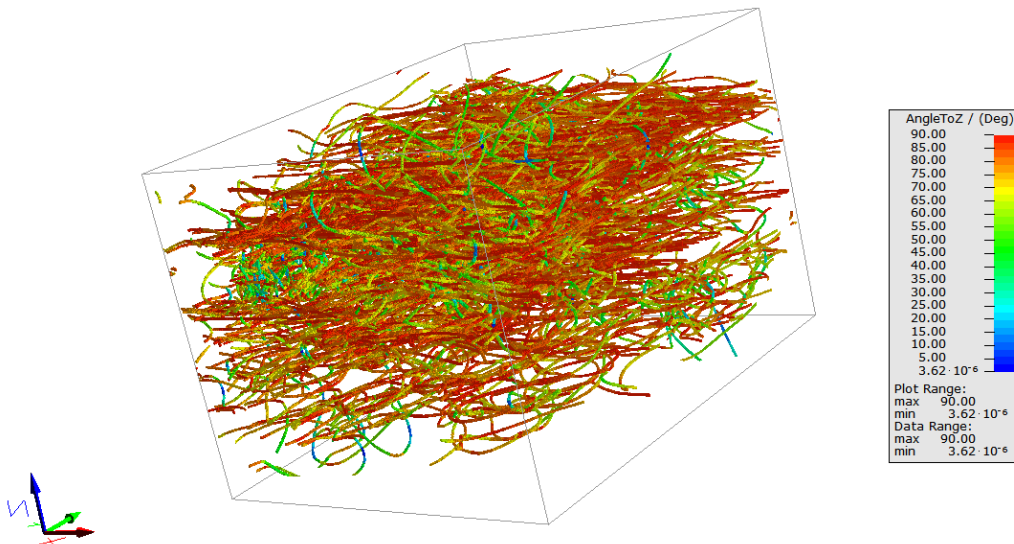

Load the structure with fibers of different type assigned to different material IDs in *.gdt format or with analytic data in *.gad format, by clicking **Load *.gdt** for **Load Fibers Segmented by Property** and **Load *.gad** for **Load Fibers Segmented by Property (analytic fibers)**, respectively.

Identification of binder and fibers, and analysis of fiber properties

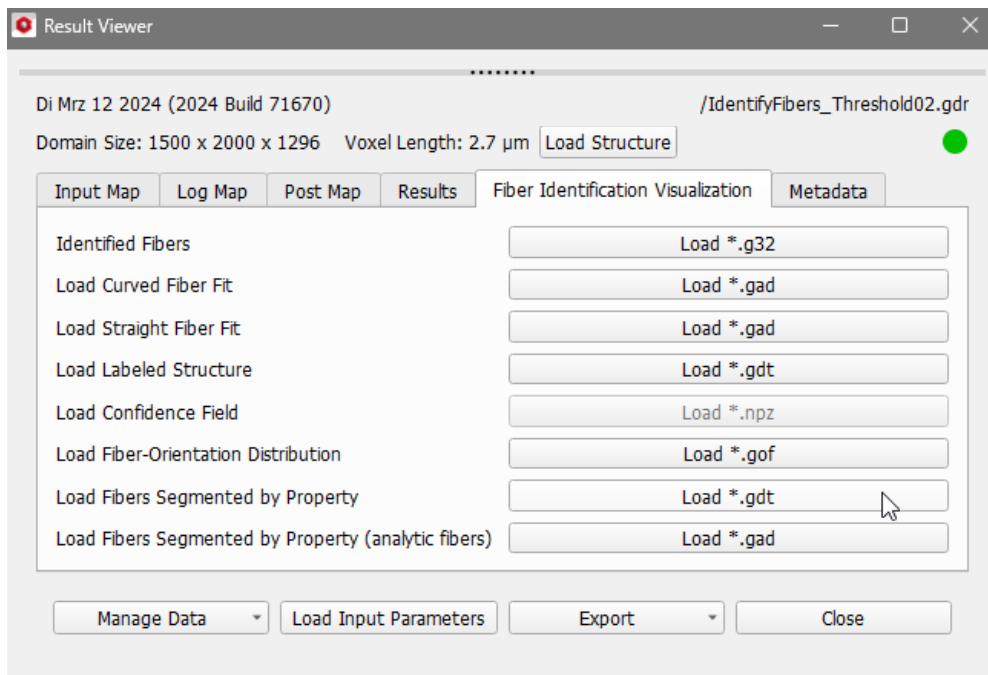

Fibers with different material IDs, according to the number of different fiber types selected under the Results tab (see page [57](#)), are shown in the Visualization Area.

Material Information:
ID 00: Pore [invis.]
ID 01: Fiber Type 1 (Solid)
ID 02: Fiber Type 2 (Solid)

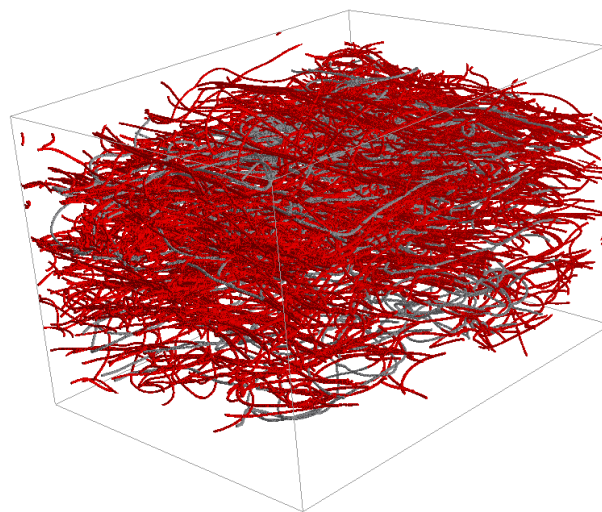

IDENTIFY BINDER (AI)

The separation between solid and pores of a structure, can usually be done using image processing methods during the import of the scanned data sets (see the [ImportGeo-Vol](#) handbook for more details). However, the separation of binder from fibers is often not possible, since they have the same gray values in the scan.

The example shown here, is a part of the imported FIB/SEM image of a carbon paper gas diffusion layer (GDL) used for a proton-exchange membrane (PEM) fuel cell. The fibers and binder contained in it are undistinguishable by their gray value in the FIB/SEM image.

The input data used, as well as a detailed description of the necessary processing steps, can be found in the tutorial *Digital analysis of fibers and binder content of a carbon paper GDL*, on the [GeoDict website](#).

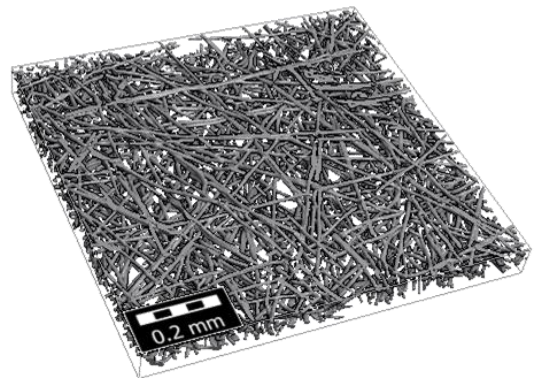

Some exemplary slices of the structure in X and Z-direction, imported into **GeoDict**, are shown here.

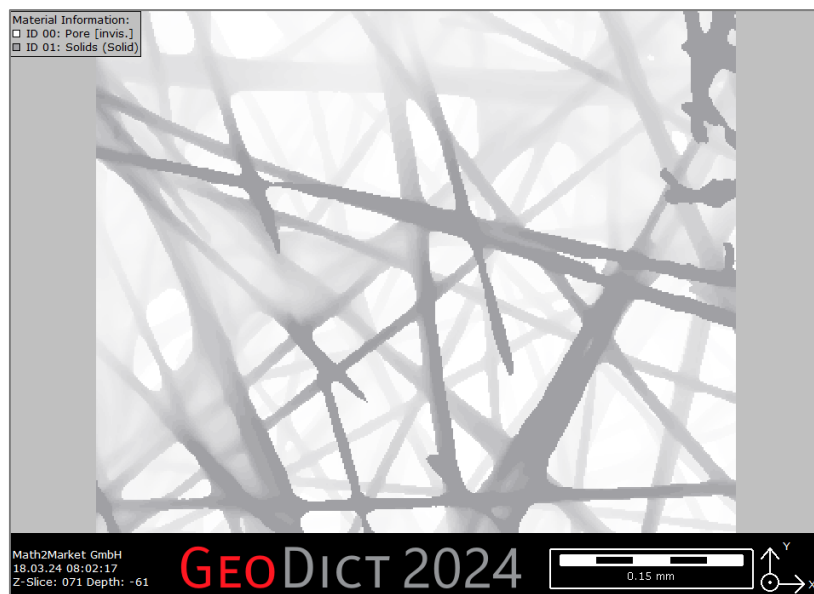

Identification of binder and fibers, and analysis of fiber properties

Details on how to import the image and to separate between pores and solid material, can be found in the tutorial *Digital analysis of fibers and binder content of a carbon paper GDL*, on the [GeoDict website](#).

To start, select **Analyze** → **FiberFind** from the menu bar and, in the **FiberFind** section, select **Identify Binder (AI)** from the pull-down menu. Click the **Options' Edit...** button.

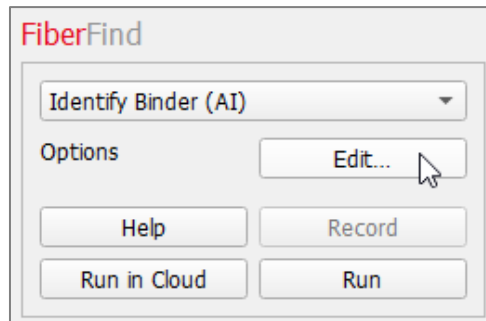

The **Binder Identification** dialog that opens includes the **Binder Identification**, the **Solver Options** and the **Equations & References** tabs. The **Solver Options** tab is similar to the **Solver Options** tab for **Identify Fiber (AI)**, explained in pages 43ff.

On the **Binder Identification** tab, select the neural networks available under **Neural Network**. GeoDict provides one neural network, which application constraints, like the fiber cross-section or diameter for that the neural network was trained, are listed in the **Description** field.

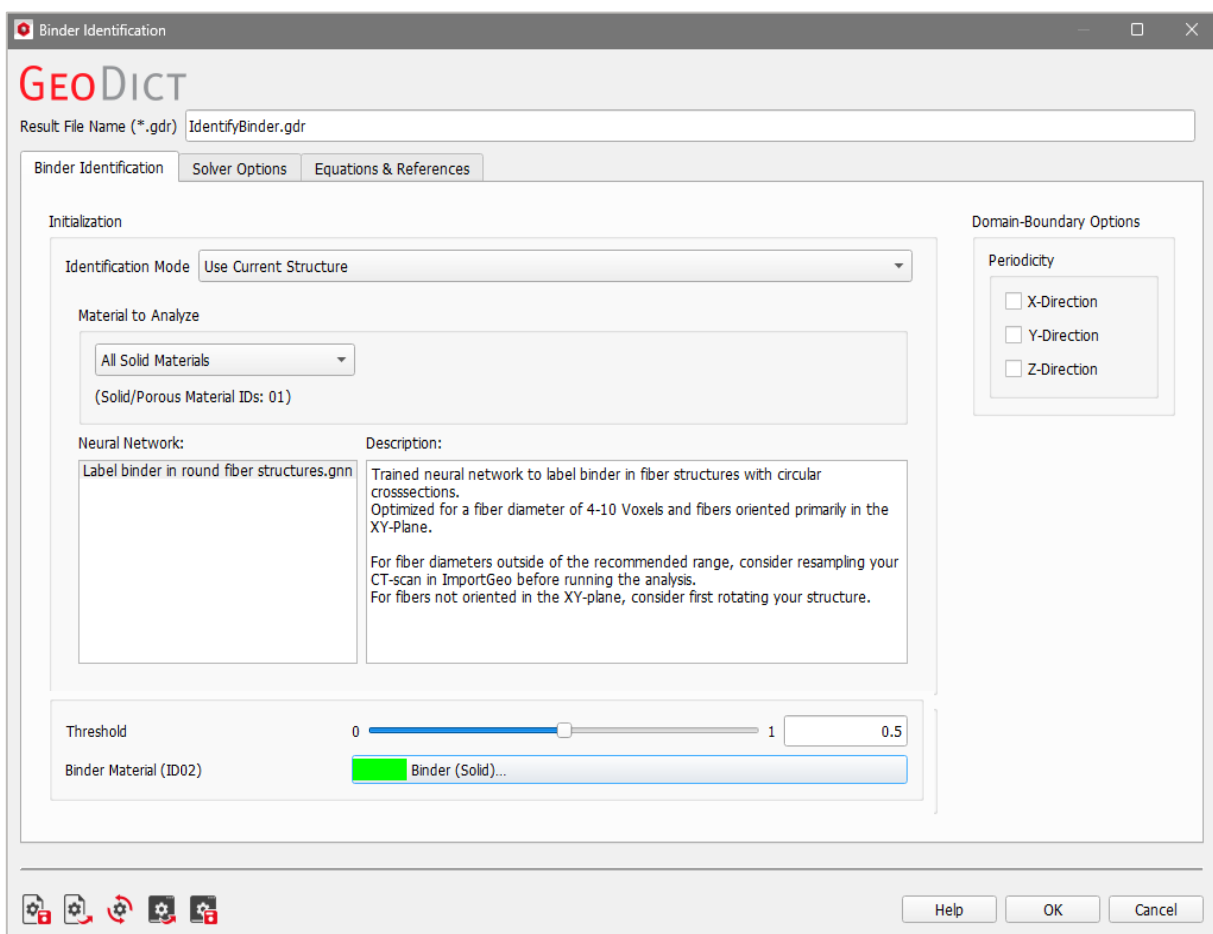

Neural networks trained with **GeoDict-AI** can be used by copying the corresponding .gnn-file into the installation directory for **Identify Binder (AI)** (e.g. in C:\Program Files\Math2Market GmbH\GeoDict 2024\FiberFind\IdentifyBinder). Then, these neural networks appear as further options in the **Neural Network** field.

The **Material to Analyze** panel offers the choice of whether the binder identification should be applied to all solid and porous materials in the structure or only on a subset, defined either by choosing material IDs or materials.

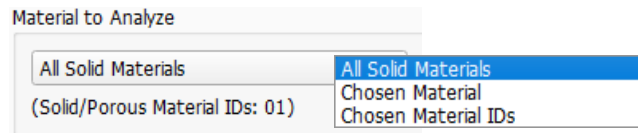

The neural network provides probabilities about whether a solid voxel is binder or not. The **Threshold** parameter defines the limit for this labelling and can therefore be defined by the user between 0 and 1 (default 0.5).

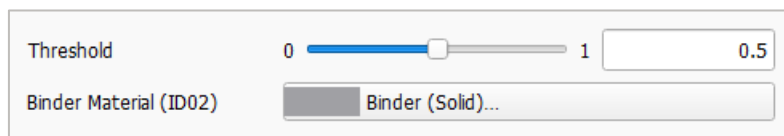

The **Binder Material** specifies the material to label the binder. The material chosen should be different from the material of any solid or pore material present in the original structure. The ID assigned to the binder material is the first ID that is not present in the current structure.

Two choices are available as **Identification Mode: Use Current Structure** and **Load Neural Network Output**.

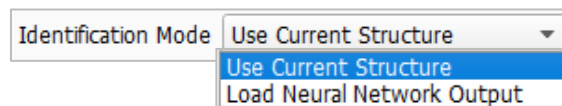

The default **Use Current Structure** applies the binder identification to the structure currently available in **GeoDict** memory and is used for most of the cases. If the evaluation of the output of the neural network should be run again, with a different threshold and without having to re-run the neural network inference step, **Load Neural Network Output** may be chosen.

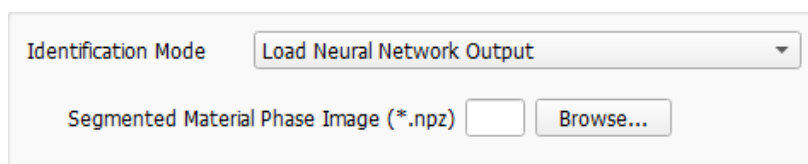

Browse to a .npz file from the result folder of a previous run of **FiberFind - Identify Binder (AI)**. Since already the output of the neural network is used in that case, no selection of **Neural Network** or **Material to Analyze** is possible and the loaded structure needs to be the same.

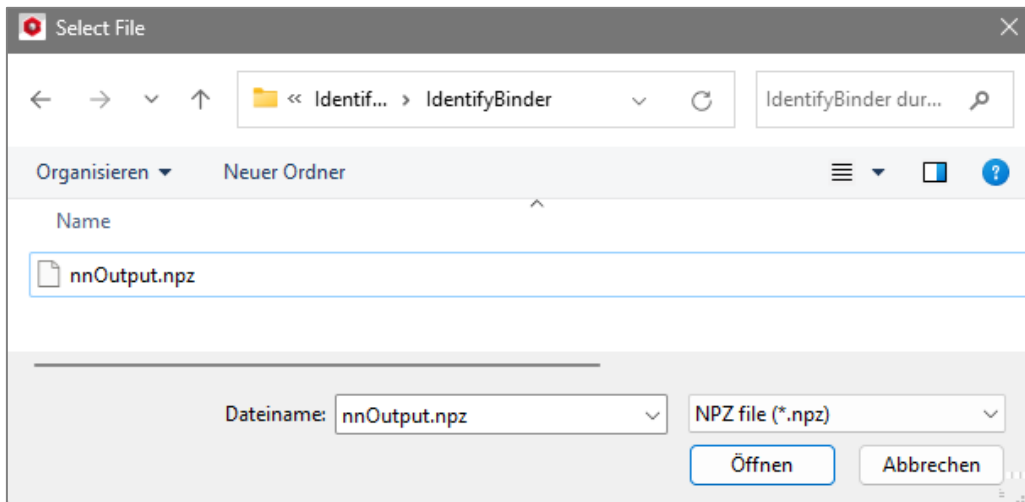

Select one or several boxes on the **Domain-Boundary Options** panel if the underlying structure for the binder identification is periodic in one or several directions. However, periodicity is unusual for most 3-D scans and this setting is rarely used.

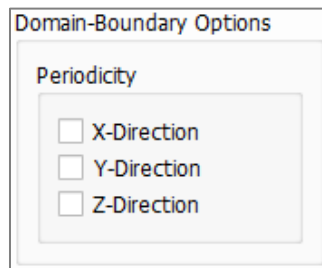

On the **Equations & References** tab, references for the binder identification can be found.

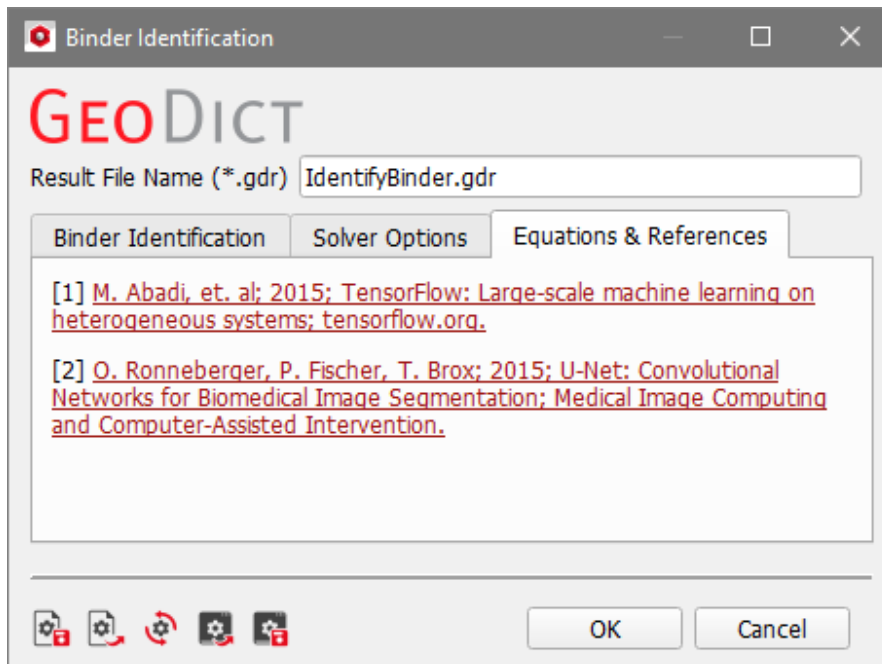

BINDER IDENTIFICATION RESULTS

After the successful binder identification, the GeoDict Result Viewer opens for the result file (.gdr). Under the **Results - Report** tab, the percentage of solid voxels identified as binder is shown.

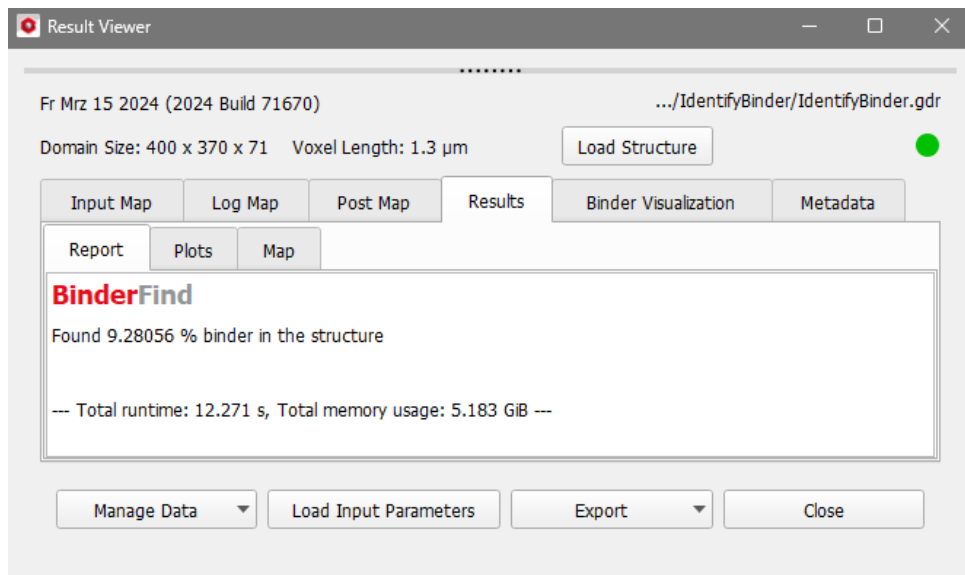

In the **Results - Plots** subtab the binder distribution is presented in form of binder percentage for each layer in z-direction of the structure.

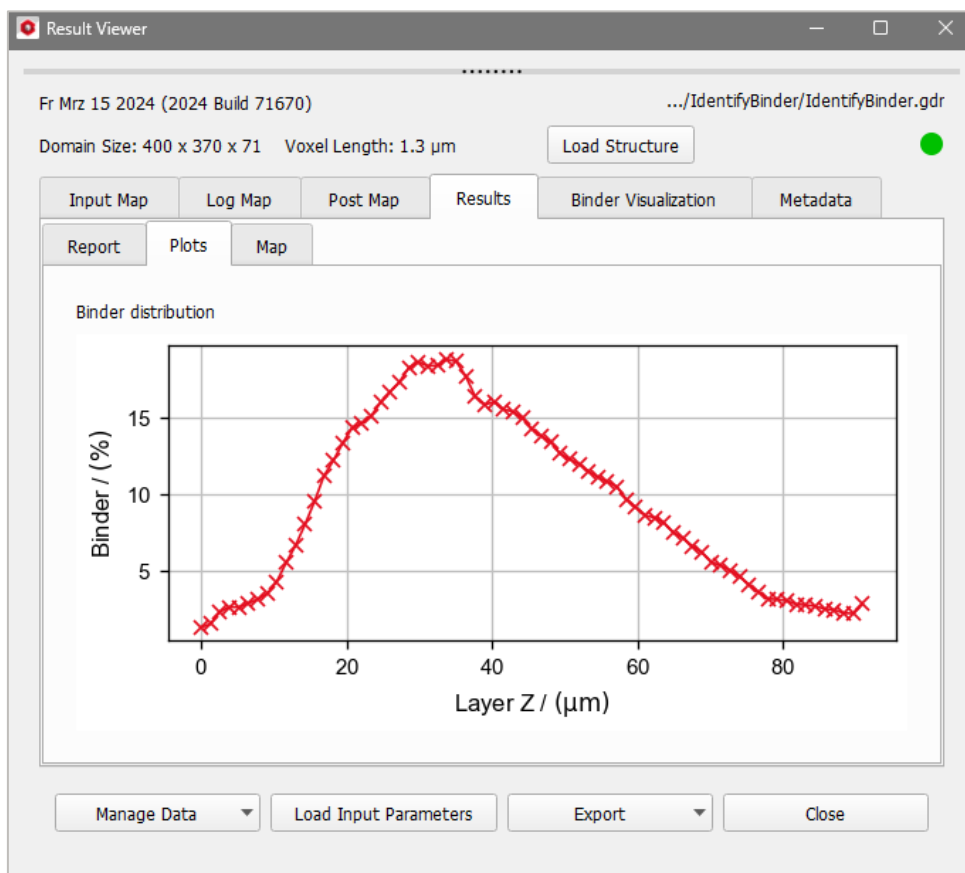

Load the structure with identified binder, by clicking **Load *.gdt** under the **Binder Visualization** tab.

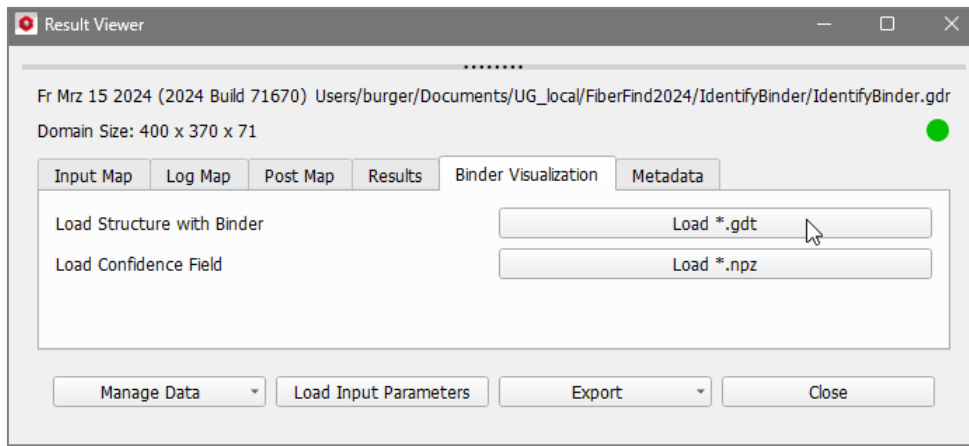

The same slices of the structure as shown above in 2D (page [61](#)), can be seen here, now with binder separated from the fibers.

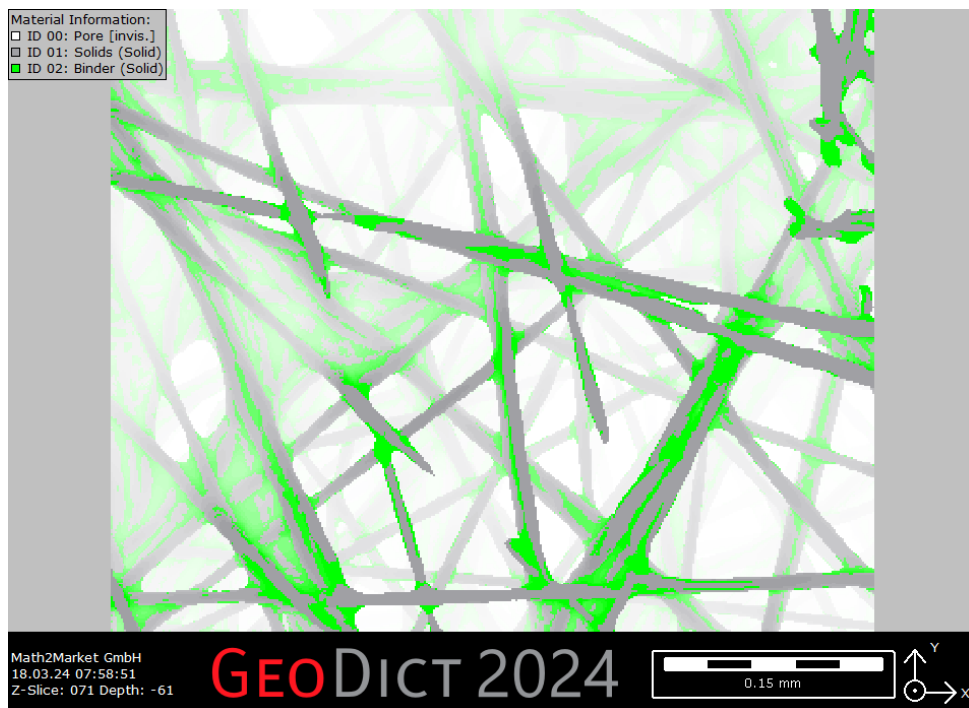

In the 3D visualization, the distribution of binder between the fibers is visible for the whole domain.

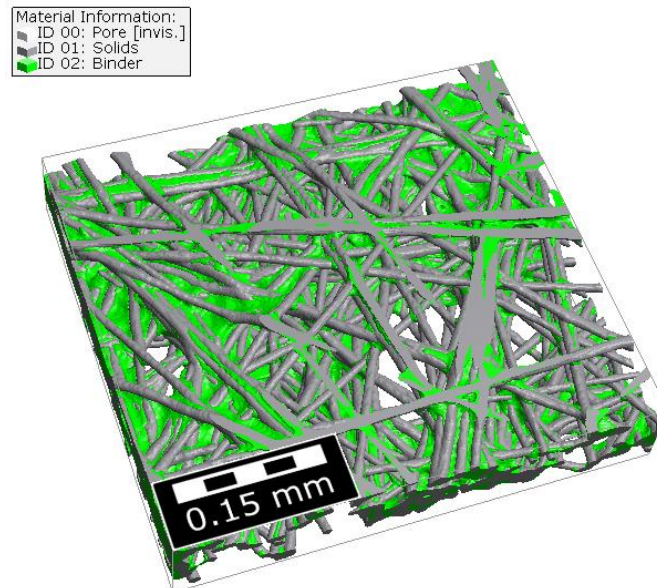

Load the confidence field, by selecting **Load *.npz** under the **Binder Visualization** tab, i.e., the unsegmented data of the binder identification.

In order to verify and comprehend the binder identification process it might be useful to simultaneously visualize the **Structure** and the **Volume Field**. For a better visibility choose **Transp. Mode** as **Volume** and edit the **Transparencies Options** for Material ID 01 (fibers and binder coupled) such that you can see it properly (e.g. 0.80 like in this example).

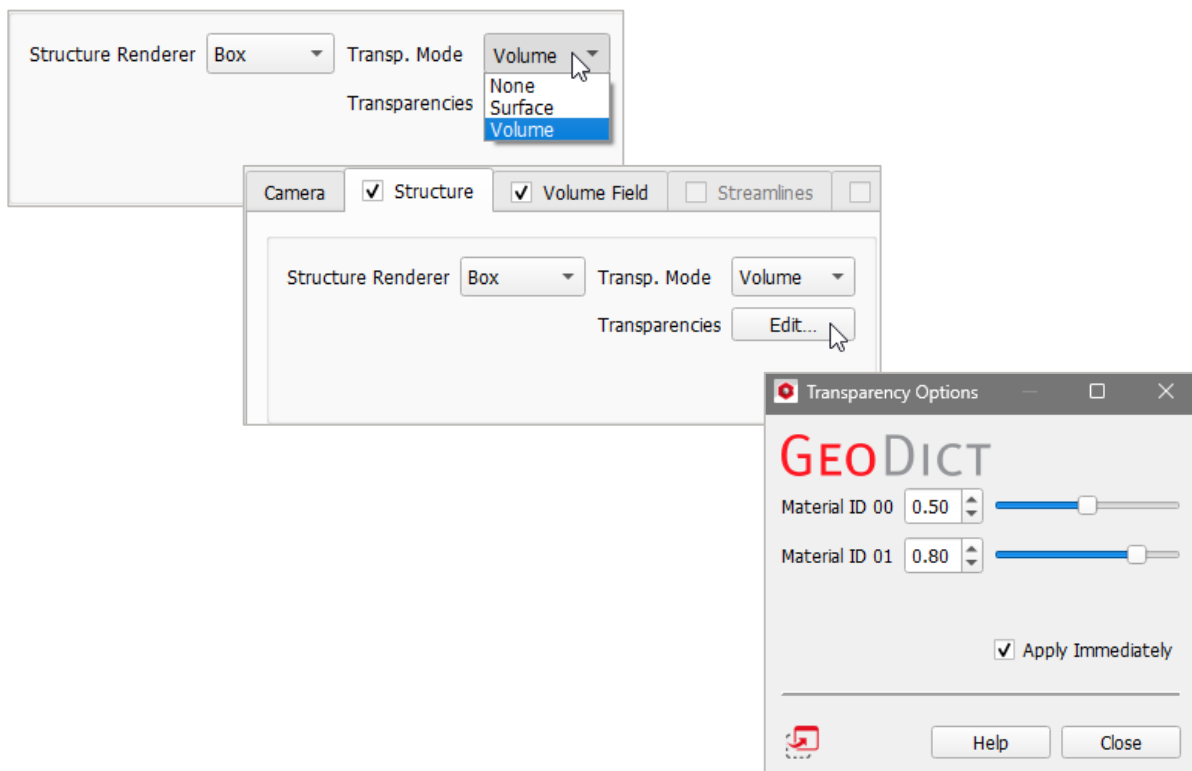

To identify voxels with a predicted confidence larger than 0.5, choose a threshold value of **0.5** and the Clip Mode \geq on the **Volume Field** tab. The identified binder voxels are now displayed in green to red and the remaining solid voxels in (transparent) gray.

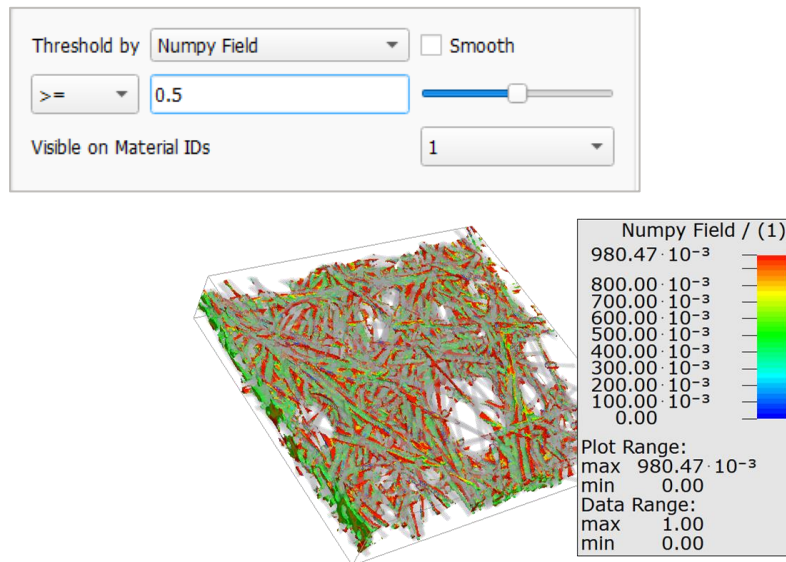

This can be compared, e.g., with the result for a threshold of 0.8, where less voxels are identified as binder (displayed in orange and red), see figure on the right.

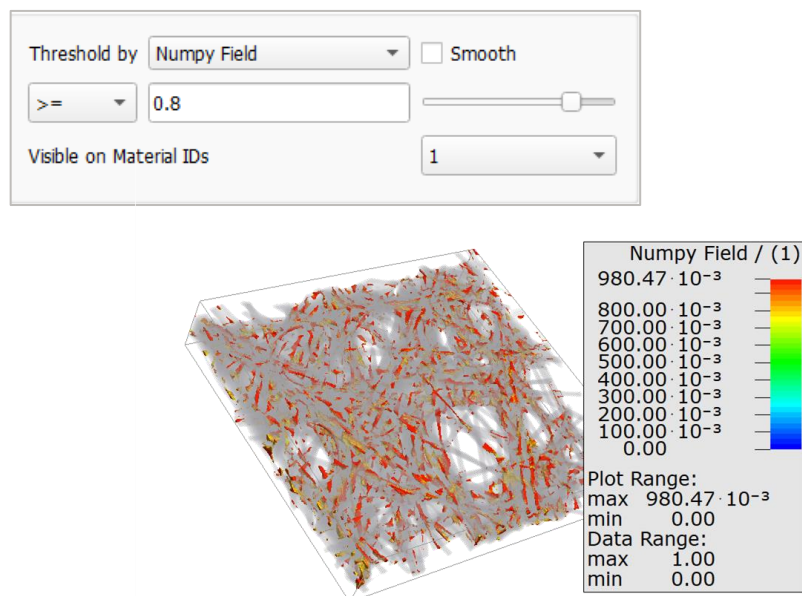

BINDER IDENTIFICATION VALIDATION

With the subfolder **FiberFindSetupUserGuide**, that is available in the folder **FiberFind** of the **GeoDict** installation folder, we provide a short example to demonstrate, how the results of **FiberFind** – Identify Binder (AI) can be validated, and to illustrate the essence of the method by testing the algorithm.

The example can be run directly from this folder if you have write access there. However, we recommend creating a copy of the folder first, and use this copy to run the example.

First change the project folder to **FiberFindSetupUserGuide** by selecting **File** → **Choose Project Folder** → **Select Project Folder** in the menu bar and navigate to the folder **FiberFindSetupUserGuide**.

In the folder **FiberFindSetupUserGuide** the structure **fiberFindInstallationTest.gdt** is provided, which can be loaded by selecting **File** → **Open structure (*.gdt, *.gad)...** in the menu bar.

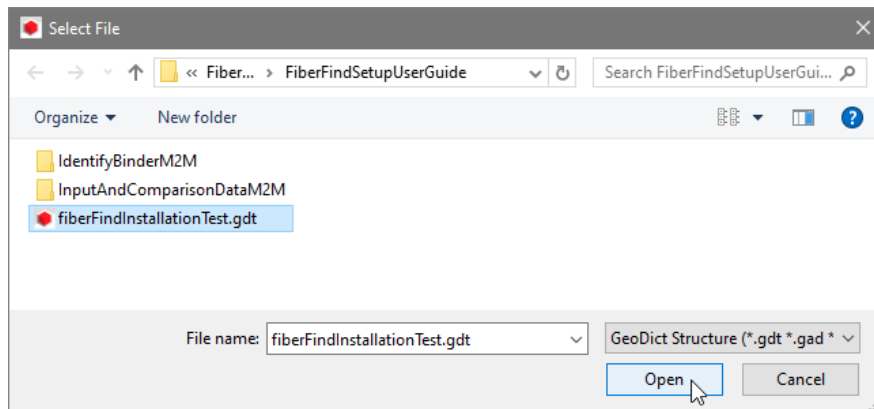

If the structure appears in 2D, press **Ctrl-3** on the keyboard or select **View** → **3D Rendering** in the menu bar. The structure displayed in the Visualization area shows binder at the point where two fibers join, but fibers and binder are undistinguishable by their material ID. It should look like this:

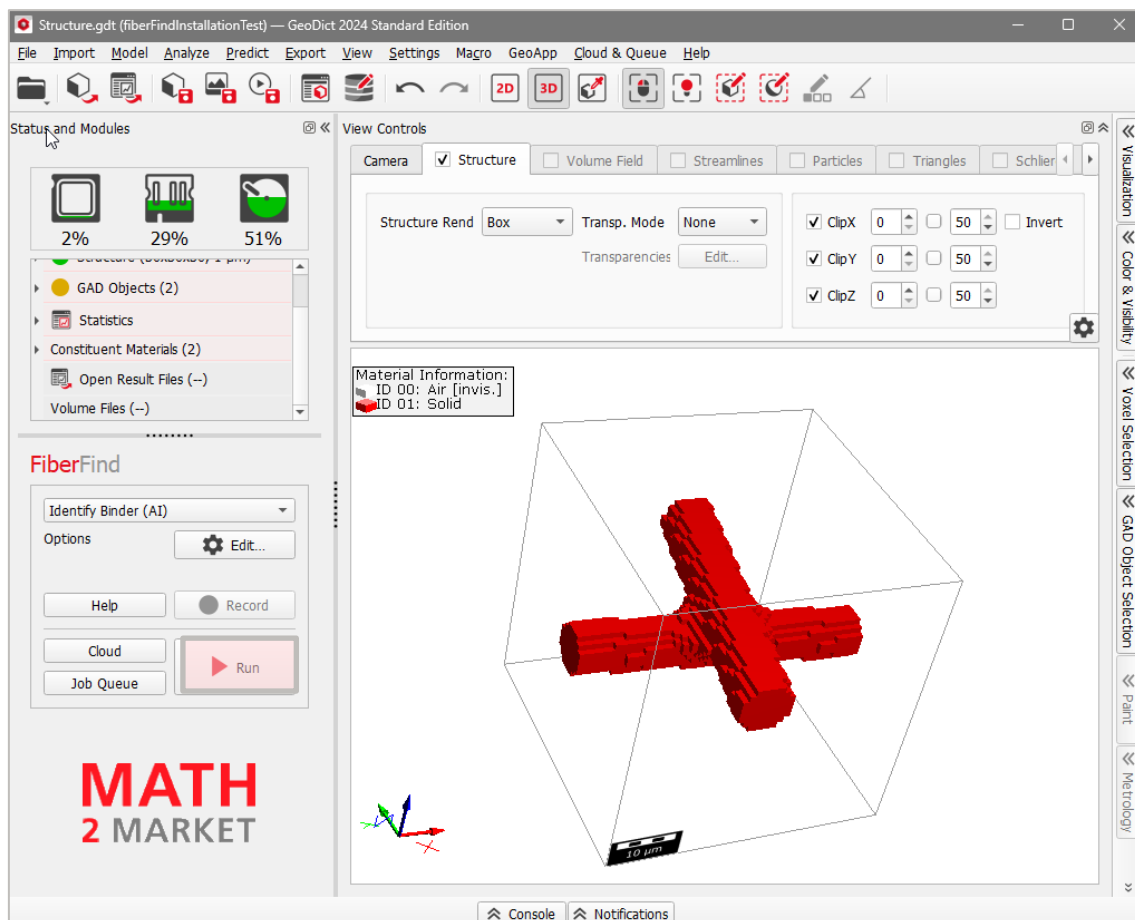

After choosing the default settings and neural network (see page [62](#)), click **Run** to identify the binder in this structure.

After the computation, the **GeoDict Result Viewer** opens and shows the results of the computation.

Identification of binder and fibers, and analysis of fiber properties

For this example **GeoDict** reports that 0.22 % of the volume is identified as binder:

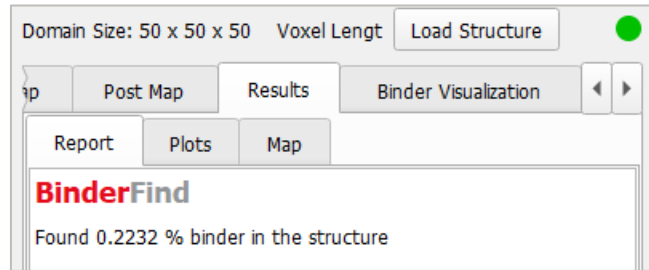

The labeled binder is displayed in **GeoDict** by clicking **Load *.gdt** on the tab **Binder Visualization**:

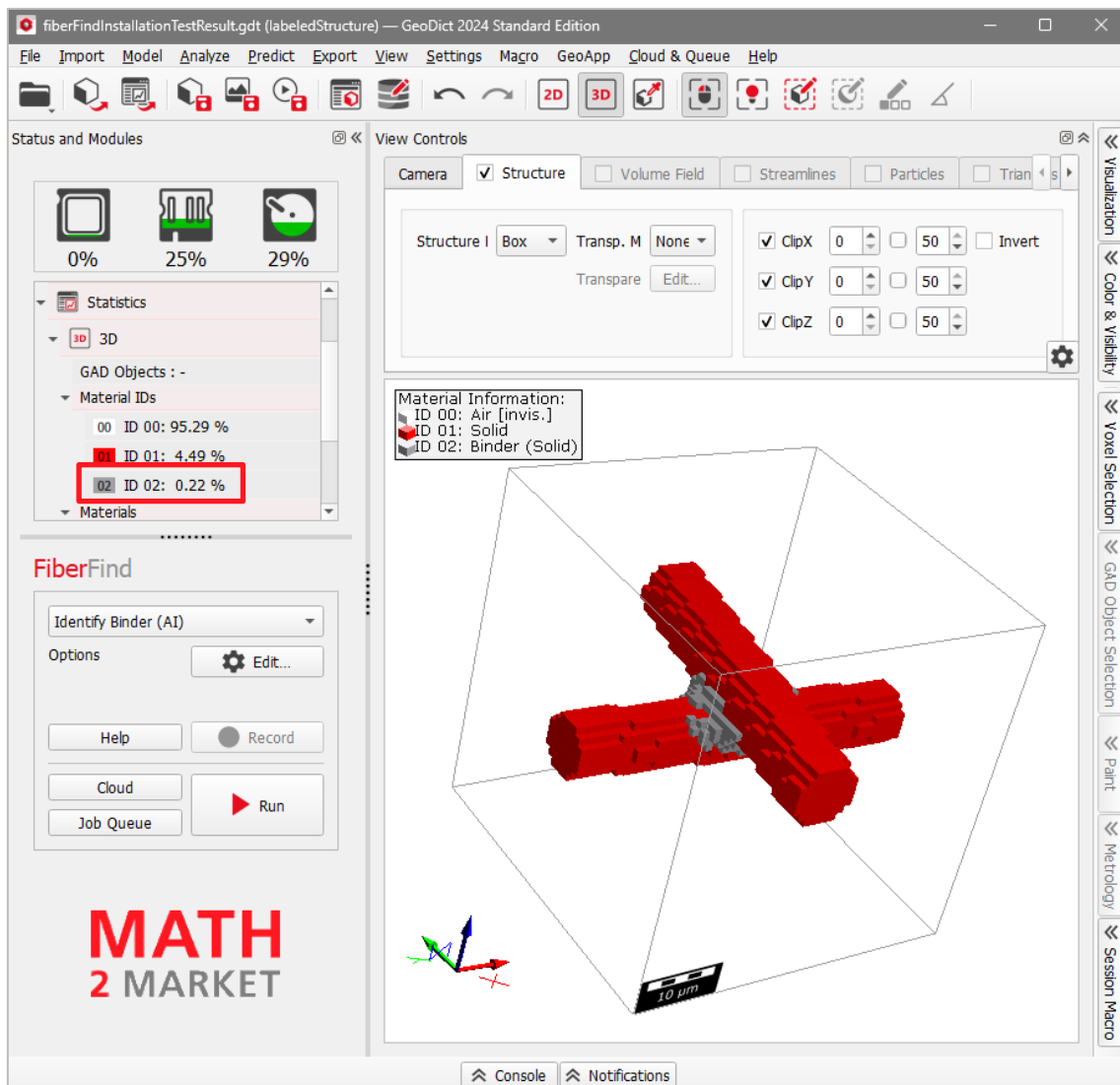

Now the structure can be saved as **fiberFindInstallationTestResult.gdt** in the project folder for further comparison and validation steps.

MEASURE THE QUALITY OF THE ALGORITHM

The fibers and binder in the structure **fiberFindInstallationTest.gdt** in the section above were generated in **GeoDict**, making it now possible to check how well the algorithm recovers the original data. The generation process was as follows:

First, **GadGeo** was used to generate two fibers that are oriented almost perfectly in the x-y plane. The generated fibers are saved in the **fibers.gad** file inside the **InputAndComparisonDataM2M** folder.

Next, binder was added by morphological operations with **Model** → **ProcessGeo** → **Add Binder**. The resulting structure can be found in the file **fibersAndBinder.gdt** in the **InputAndComparisonDataM2M** folder. To facilitate the comparison with the output of the algorithm, the fibers in this file have been recolored and the resulting structure is saved in the file **fibersAndBinderRecolored.gdt** in the same folder.

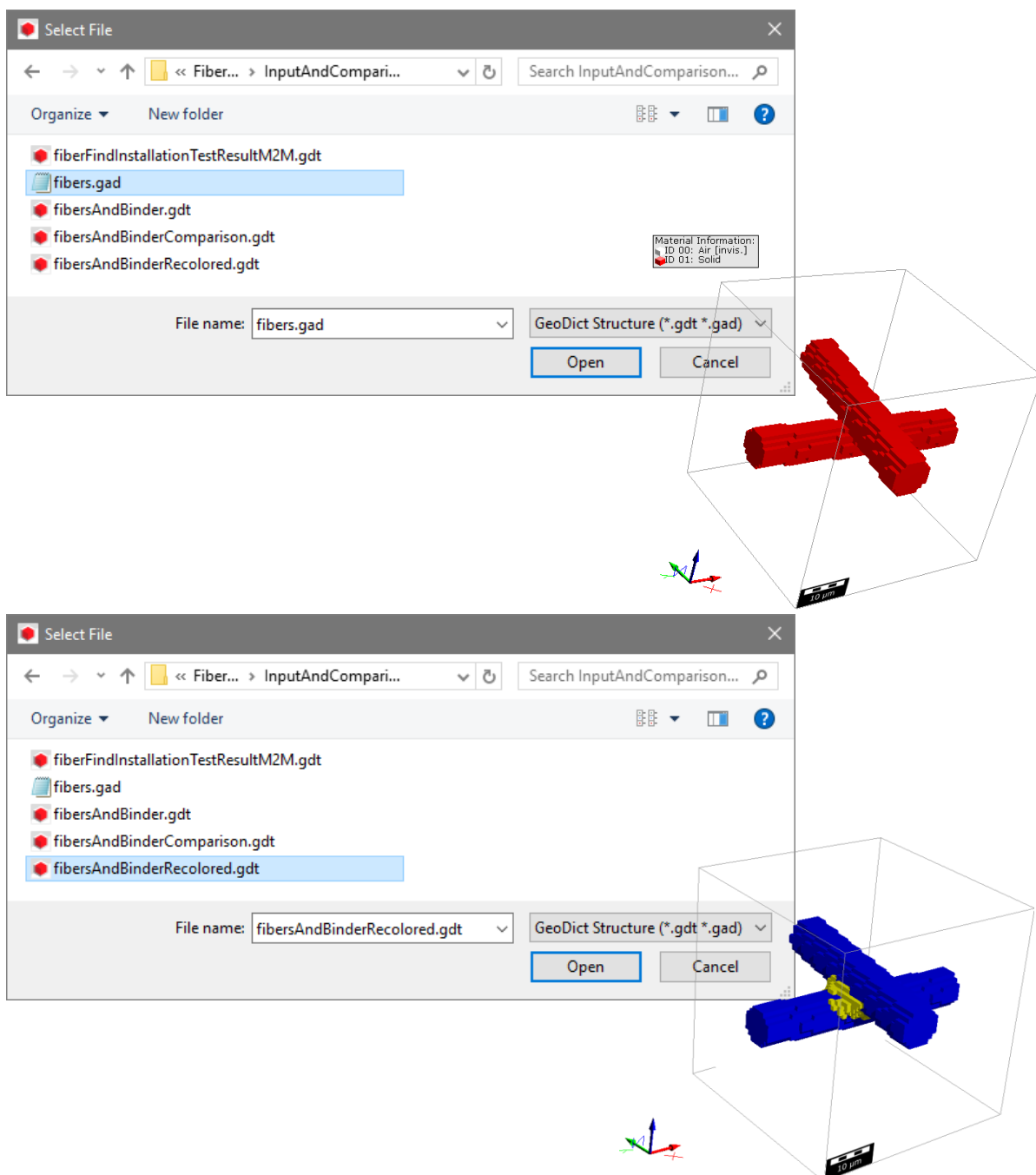

Finally, the result of **FiberFind – Identify Binder (AI)** binder identification is compared with this structure by adding the **fibersAndBinderRecolored.gdt** structure to the **fiberFindInstallationTestResult.gdt** result structure with **LayerGeo**.

Therefore, the result structure **fiberFindInstallationTestResult.gdt** needs to be loaded in **GeoDict**.

Then, select **Model** → **LayerGeo** in the menu bar and choose **Add** in the **LayerGeo** section of the **GeoDict** main GUI.

Click **Edit** and browse to the folder **InputAndComparisonDataM2M**. Select the **Voxel Geometry** as Geometry Mode. Then select **MaterialID** as the Material Mode for the addition and the file **fibersAndBinderRecolored.gdt**.

Click **OK** and then click **Run** in the **LayerGeo** section of the **GeoDict** main GUI.

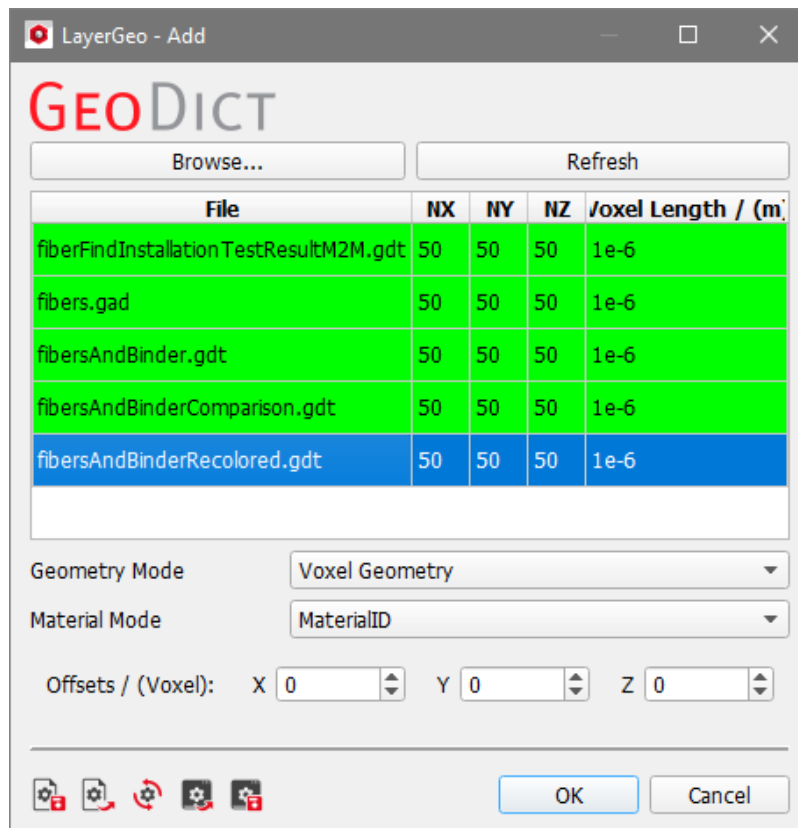

The next step is to change the Material ID numbers in the resulting structure (which is available also as **fibersAndBinderComparison.gdt** in the folder **InputAndComparisonDataM2M**), by choosing **Model** → **ProcessGeo** → **Reassign Materials & IDs** (from the pull-down menu) to facilitate comparison with the original structure created in **GeoDict**.

Reassign Material ID 5 to Material ID 1 and Material ID 10 to Material ID 2. Now, the original colors (red, gray) match at the voxels where both original data and analyzed data agree.

All voxels with IDs 1 and 6 were fiber voxels in the original structure, voxels with IDs 2 and 9 were binder voxels in the original structure. Reassign a solid material to both ID 06 and ID 09 with the information **Identified as binder** and **Identified as fibers** using **ProcessGeo** → **Reassign** → **Reassign Material of Material ID**.

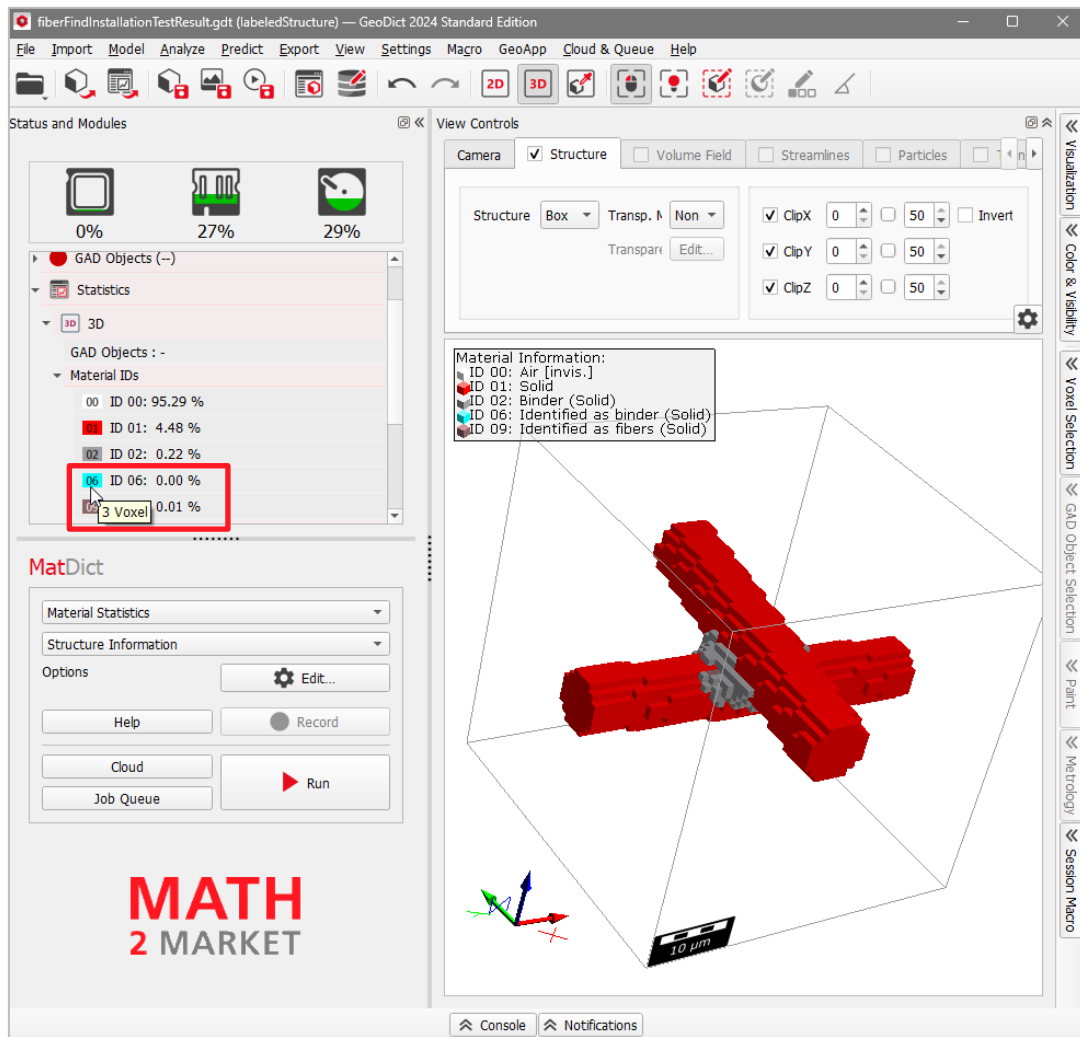

The tool tip information of each material ID, presented in the **Statistics** overview of the **Status and Modules** panel, shows the number of voxels for each category. In this example 3 original fiber voxels (cyan, ID 06) were labeled as binder by the algorithm and 16 original binder voxels (brown, ID 09) were classified as fibers. All other voxels were labeled correctly: 5598 fiber voxels (red, ID 01) and 276 binder voxels (gray, ID 02).

Formally, the volume fractions can be evaluated after selecting **Analyze** → **MatDict Material Statistics** → **Structure Information** in the menu bar. The results are shown below.

<p>Air, Manual 1, Manual 2</p> <p>Volume fraction: Material Air: 0.952856 Material Manual 1: 0.044808 Material Manual 2: 0.002336 MaterialID 0: 0.952856 MaterialID 1: 0.044808 MaterialID 2: 0.002336</p> <p>Solid weight percentage:</p>	<p>Volume fraction: Material Air: 0.952856 Material Manual 1: 0.044784 Material Manual 2: 0.002208 Material Manual 3: 2.4e-05 Material Manual 4: 0.000128 MaterialID 0: 0.952856 MaterialID 1: 0.044784 MaterialID 2: 0.002208 MaterialID 6: 2.4e-05 MaterialID 9: 0.000128</p>
--	--

On the left, observe the data for the original structure with only three materials, two of them are solid materials (**fibersAndBinder.gdt**).

On the right, the data for the comparison with the result of the binder identification shows five materials, four of them for solid materials.

The volume fractions for Pore and Manual agree exactly because Identify Binder (AI) will not change a pore to a solid or vice-versa.

MaterialID 1 and **MaterialID 2** are assigned to fibers and binder in both cases. **MaterialID 6** indicates fiber voxels mistakenly labeled as binder voxels and **MaterialID 9** indicates binder voxels mistakenly labeled as fiber voxels.

In summary, we see that:

1. Identify Binder (AI) recognizes 99.9% of the fiber voxels as fiber voxels correctly and recognizes about 94.5% (0.002208/0.002336) of the binder voxels correctly as binder.
2. Identify Binder (AI) almost never classifies a fiber voxel falsely as a binder voxel, but classifies the remaining 5.5% (0.000128/0.002336) of the binder voxels incorrectly as fibers.

Technical
documentation:

Anja Streit
Rolf Westerteiger
Lilli Burger
Barbara Planas

MATH
2 MARKET

Math2Market GmbH
Richard-Wagner-Str. 1, 67655 Kaiserslautern, Germany
www.geodict.com