

FIBERGEO

User Guide

GeoDict release 2024

Published: April 22, 2024

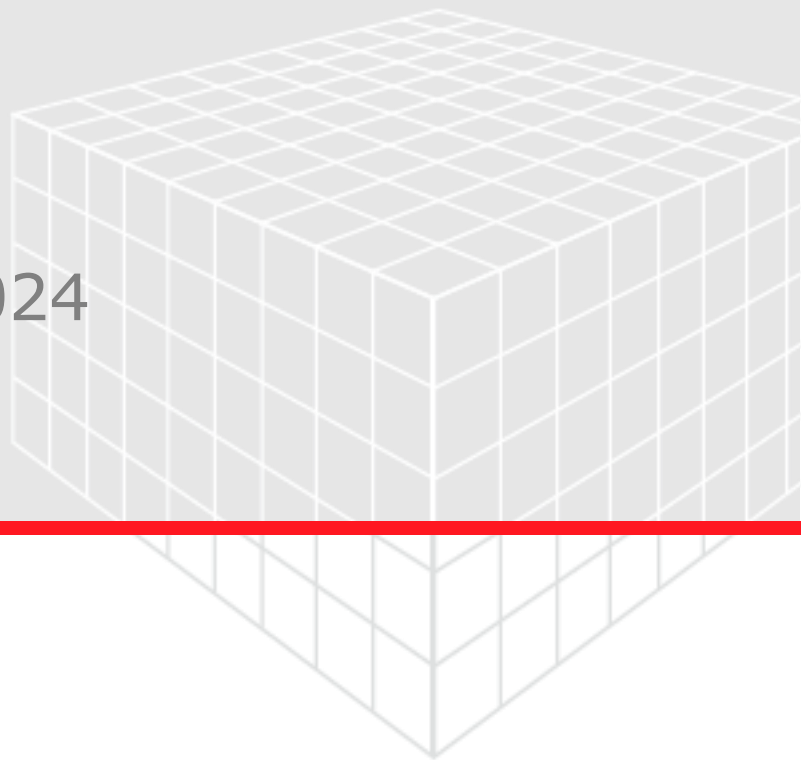

GEO DICT

<https://doi.org/10.30423/userguide.geodict>

© Math2Market GmbH 2024

Citation:

Janine Hilden, Sebastian Rief, Barbara Planas. GeoDict 2024 User Guide. FiberGeo handbook. Math2Market GmbH, Germany, doi.org/10.30423/userguide.geodict

All rights reserved. It is not permitted to reproduce the book or parts thereof in any form by photocopy, microfilm or other methods or to transfer it into a language suitable for machines, in particular data processing systems, without the express permission of the publisher. The same applies to the right of public reproduction.

The handbooks in the User Guide series of Math2Market GmbH can be obtained from:

Math2Market GmbH
Richard-Wagner-Strasse 1
67655 Kaiserslautern
Germany

Phone: +49 631 205 605 0
Fax: +49 631 205 605 99
Email: info@math2market.de
Web: www.math2market.de

GENERATING AND MODELING FIBROUS STRUCTURES	1
FIBERGEO SECTION	2
CREATE FIBERS	4
Create Options	5
Fiber Options	28
Fiber Overlap	79
Result Options	82
PILE FIBERS	83
Pile Options	84
Fiber Options	89
Fiber Motion	89
Result Options	94
DISTRIBUTE	95
ADD BINDER	98
General Options	99
Binder Distribution	107
FIBER GEOAPPS	109
Fiber GeoApps gallery	110
CREATE GAUSSIAN RANDOM FIELDS	111
GAUSSIAN RANDOM FIELD GENERATOR	111
PARALLELIZATION	113
PARALLELIZATION BENCHMARK RESULTS	113

GENERATING AND MODELING FIBROUS STRUCTURES

Starting from random distributions of fibers, **FiberGeo** creates virtual non-woven and fiber reinforced composites.

To generate fibrous material models, **FiberGeo** requires the input of fiber material and form, and the desired statistical properties of the resulting structure, such as size, amount of the solid phase, etc. The fibers can be straight or curved, where the profile shape can be varied (circular, elliptical, rectangular, cellulose, etc.). The orientation of fibers and the distribution of fiber parameters can be specified. It is possible, for example, to generate structures with prescribed solid volume percentage, prescribed density or prescribed grammage.

Input:

Fiber material and form

Desired structure properties: sample size, solid volume fraction, orientation...

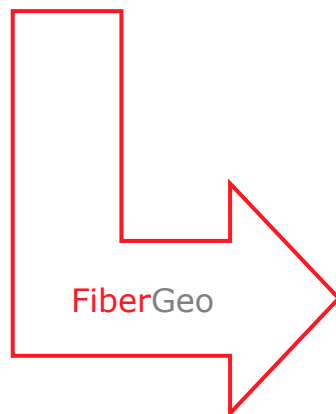

Output:

Fibrous structure

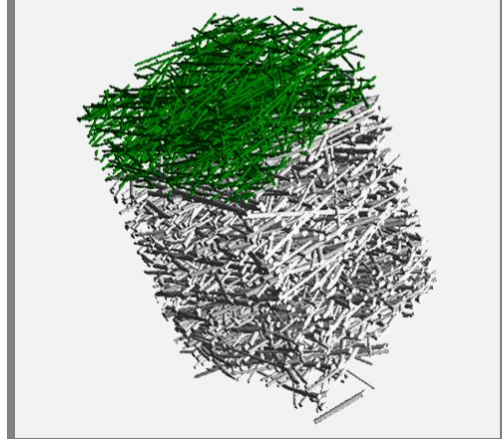

FiberGeo fibrous structures are based on given statistical properties that can be estimated e.g. from 3D images (CT-scan), from 2D images like REM, from certain material properties or from the knowledge of the underlying production process. These properties can also be computed in **GeoDict** directly from the scan using the module **FiberFind**. The generated non-woven models are available as 3-dimensional images and as analytical data (GAD, **GeoDict** analytic data), which can be used to export surface triangulations (stl-files) for CAD-programs.

Other material properties like pore-size distribution, flow resistivity (permeability, pressure drop), effective thermal and electrical conductivity, effective elasticity, effective diffusion, filter efficiency, filter capacity, and many more, can be calculated directly on the geometry models, using other **GeoDict** modules, e.g. **PoroDict**, **ConductoDict**, **FlowDict**, **ElastoDict**, **DiffuDict**, or **FilterDict**.

Important application areas are the production of glass fiber and carbon fiber reinforced composites, fibrous insulation materials, gas diffusion layers in fuel cells, filter media, dewatering felts, and many others.

FIBERGEO SECTION

FiberGeo is the default module appearing in the module section to the left of the **GeoDict** GUI at the start of **GeoDict**. Otherwise, **FiberGeo** starts when selecting **Model** → **FiberGeo** in the Menu bar. **FiberGeo** allows generating fibrous nonwoven structures.

The **FiberGeo** headed module section contains a pull-down menu containing the available **FiberGeo** commands:

- With **Create**, fibrous structures with user-defined parameters can be generated. The fibers appear randomly in the domain.
- When using **Pile**, the fibers fall from the top of the domain and settle in their final position after shifts and rotations.
- If object information is available, fibers can be redistributed in the given volume using **Distribute**. For example, such information is available after creating a structure with **FiberGeo**. Distributing the fibers is often used after a piling step to obtain a more homogeneous material.
- **Add Binder** adds material in the shape of a concave meniscus in locations where fibers in that structure are close together. This models binder in fibrous structures.
- **Predefined** creates some predefined materials from different application areas.

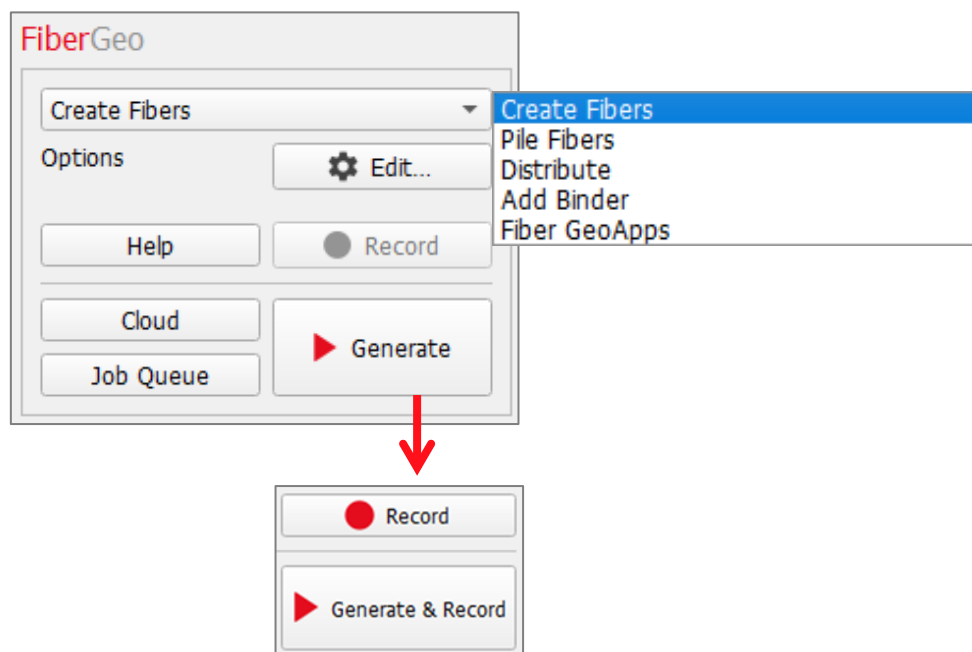

After selecting a command from the pull-down menu, the necessary parameters can be entered through the corresponding **Options Edit ...** button located in its panel.

Clicking **Generate** at the bottom of the **FiberGeo** section starts the program's generation run. The fibrous structure is created and shown in the **Visualization** area.

Macro files are recorded and saved when selecting **Macro** → **Start Macro Recording...** in the menu bar. Then, in the **FiberGeo** section, **Record** becomes active and **Generate** changes to **Generate & Record**.

Click **Cloud** to run it in the **GeoDict** cloud, see the [High Performance Computing](#) handbook of the **GeoDict** User Guide for details. To run the fiber generation on machines connected in your local network, click **Job Queue**, also explained in more

detail in the [High Performance Computing](#) handbook. If interested in cloud simulations or job queueing, contact Math2Market to apply for a GeoDict cloud or job queueing license.

The commands **Create**, **Pile**, and **Predefined** generate a new fibrous structure or a new structure in the structure currently in memory. The other commands (**Distribute** and **Add Binder**) require a valid initial structure already in memory.

For **Create** and **Pile**, a customized **Result File Name (*.gdr)** should be entered to differentiate the results of sets of **FiberGeo** generations. The resulting GDR file will be placed inside the chosen project folder.

Often it is useful to save many files with information about the structure generation process. For this, in addition to the automatically saved GDR file (GeoDict Result) and the structure model in GDT (GeoDict file) and GAD (GeoDict Analytic Data) formats, the user may save files from the **FiberGeo** run in formats Python (GeoDict Macro file), and GPS (GeoDict Project Settings file) in the project folder. Otherwise, the structure model can also be saved by selecting **File** → **Save Structure as...** in the Menu bar.

If you save the **Options** dialogs parameters into GPS (**GeoDict** Project Settings) files, you can reload them at will.

Remember to restore and reset your (or **GeoDict's**) default values through the icons at the bottom of the dialogs when needed and/or before every **FiberGeo** run. Rest the mouse pointer over an icon to see a Tooltip showing the icon's function.



CREATE FIBERS

The **FiberGeo Create Options** dialog opens when clicking the **Options' Edit...** button in the **FiberGeo** section.

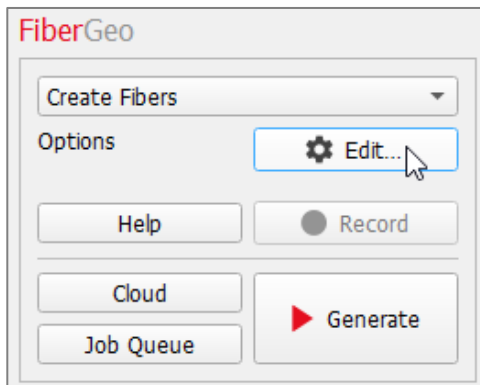

At the top left of the **FiberGeo Create Options** dialog, the name for the files containing the generation results can be entered in the **Result File Name (*.gdr)** box. The default name can be kept, or a new name can be chosen fitting the current project.

The available units (**m**, **mm**, **µm**, **nm**, and **Voxel**) are selectable from the pull-down menu at the top right of the **FiberGeo Create Options** dialog. When the units are changed, the entered values are adjusted automatically.

The options are organized into **Create Options**, **Fiber Options**, **Fiber Overlap**, and **Result Options** accessible through tabs.

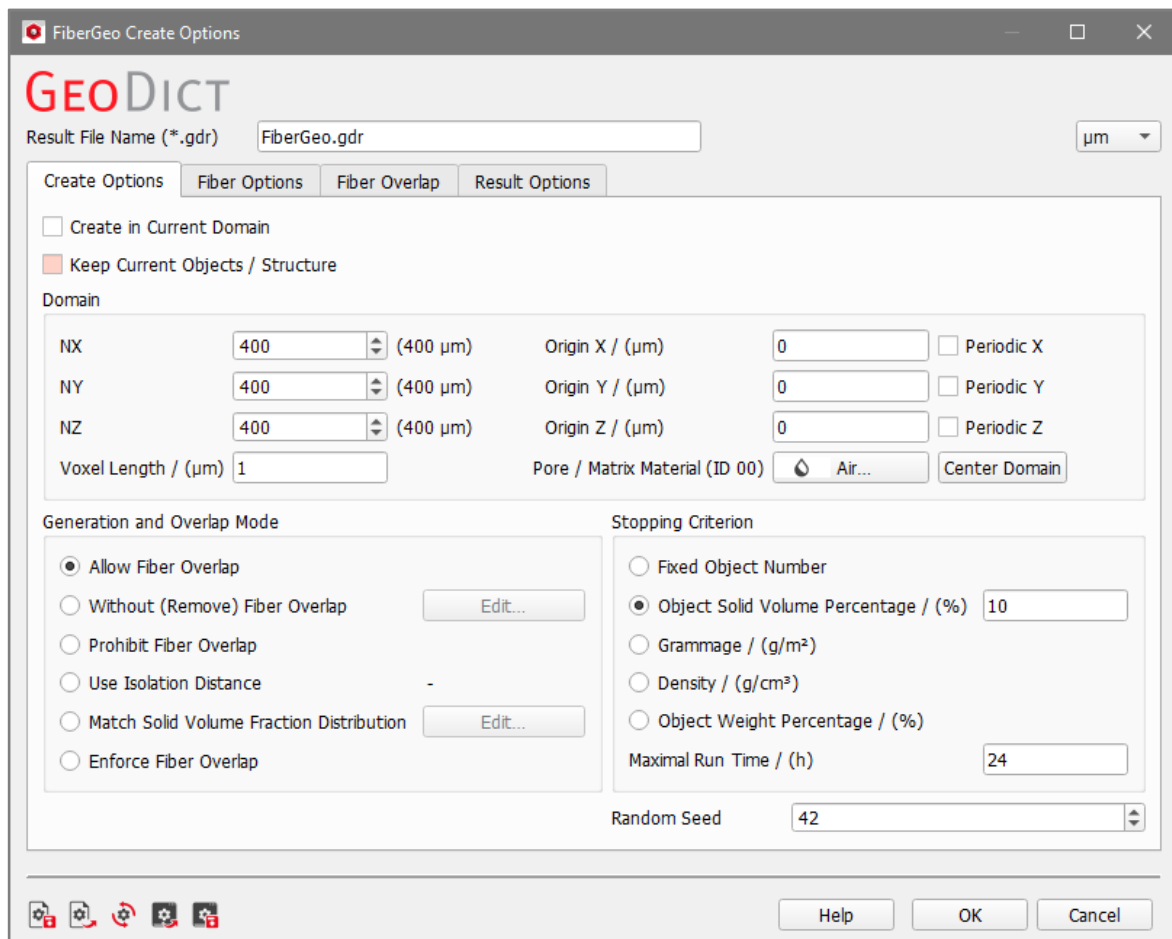

- The **Create Options** determine general properties of the resulting structure, such as size, position, resolution, and solid volume fraction.
- The **Fiber Options** define the geometrical properties of individual fiber types such as cross-section, length, and orientation. Up to eight different fiber types can be used in one structure.

- The **Fiber Overlap** defines how material IDs are defined in positions where objects overlap.
- The **Result Options** determine if and how the resulting geometry is saved.

The result files are saved in the chosen project folder (**File** → **Choose Project Folder**, in the Menu bar). If a GeoDict results file (*.gdr) with the given name already exists in the project folder, a warning message is shown at the start of the creation process. The user can either decide to back up the old file, to overwrite it or cancel and choose a new file name.

CREATE OPTIONS

The geometric properties of the fibrous structure are entered under the **Create Options** tab. These parameters are grouped into the panels **Domain**, **Generation and Overlap Mode**, and **Stopping Criterion**.

CREATE IN CURRENT DOMAIN AND KEEP CURRENT OBJECTS / STRUCTURE

When checking **Create in Current Domain**, the parameters of the domain currently in memory, are used for the generation of a new structure. Additionally, when **Keep Current Objects/Structure** is checked, the structure in memory is kept and combined with the newly generated fibrous structure.

This feature is used in combination with checking **Prohibit Fiber Overlap** or **Prohibit Overlap with Current Structure** (see page [21](#)) in the **Generation and Overlap Mode** panel.

In this way, complex models can be created. For example, the user can make fibers cover a mold that is later discarded.

Note that the parameters grouped under the **Domain** panel, including the voxel length, cannot be modified once the **Create in Current Domain** box is checked, because they are taken from the structure already in memory.

Observe the effect that checking, or leaving un-checked, **Create in Current Domain** and **Keep Current Objects/Structure** have on the generation of a fibrous structure.

Here, a mold is generated and present in memory (current structure) while polyamide PA-66 fibers are added, not keeping or keeping the mold. **Prohibit Overlap with Current Structure** is checked to avoid the PA-66 fibers to enter the mold, but the PA-66 fibers can overlap each other.

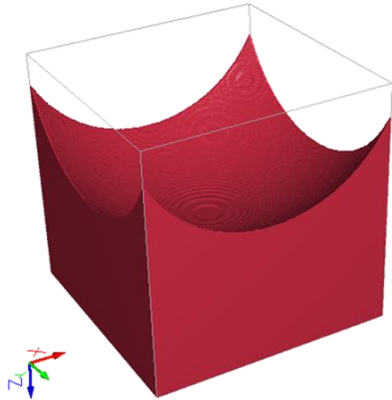

If additionally, the PA-66 fibers should not overlap each other, the more restrictive **Prohibit Fiber Overlap** should be checked instead.

The PA-66 fibers are automatically assigned the material ID 02 when keeping the current structure (with Material ID 01).

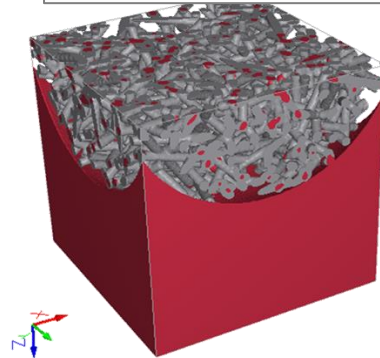
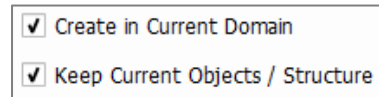
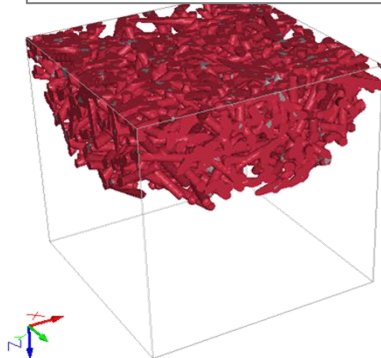
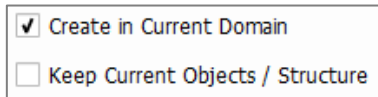

In the following example, the same mold is made, and then PA-66 fibers are generated into the mold, which is not kept. Then, the current structure made of PA-66 fibers is kept and PET fibers are generated in the same form that the mold previously had.

In every step, overlap is prohibited with the current structure but not between the newly generated fibers.

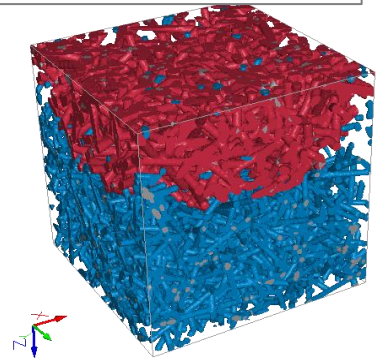
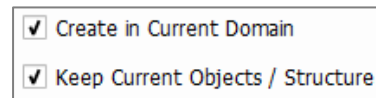
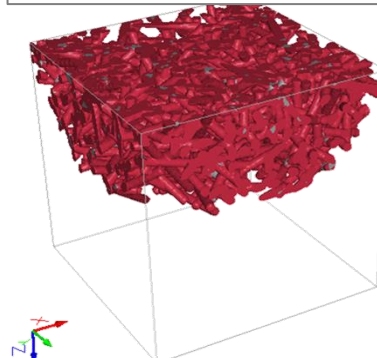
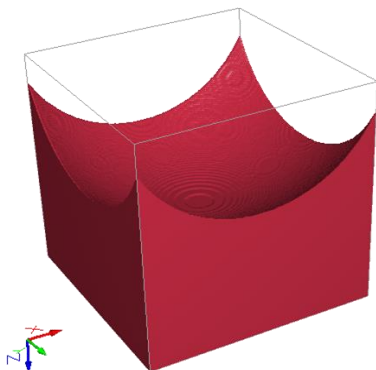
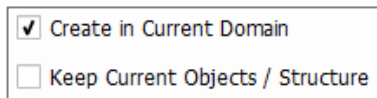

DOMAIN

The **Domain** panel contains the parameters defining the structure size (**NX**, **NY**, and **NZ**) in combination with the resolution (**Voxel Length**), as well as the **Origin** parameters, the **Periodicity** checkboxes, the **Center Domain** button, and the **Pore/Matrix Material (ID 00)** pull-down menu.

Domain					
NX	200	(200 μm)	Origin X / (μm)	0	<input type="checkbox"/> Periodic X
NY	200	(200 μm)	Origin Y / (μm)	0	<input type="checkbox"/> Periodic Y
NZ	200	(200 μm)	Origin Z / (μm)	0	<input type="checkbox"/> Periodic Z
Voxel Length / (μm)	1		Pore / Matrix Material (ID 00)	Air (Fluid) ...	Center Domain

NX, NY, NZ, and Voxel Length

The internal representation of a structure in **GeoDict** consists of rectangular 3D arrays of equally sized boxes, called volume elements or **voxels**. **NX**, **NY**, and **NZ** are the number (N) of voxels in X, Y and Z directions. The **Voxel Length** is the side length of one voxel in the chosen units. Varying the values for **NX**, **NY**, and **NZ** has the effect of changing the size of the structure in the given direction.

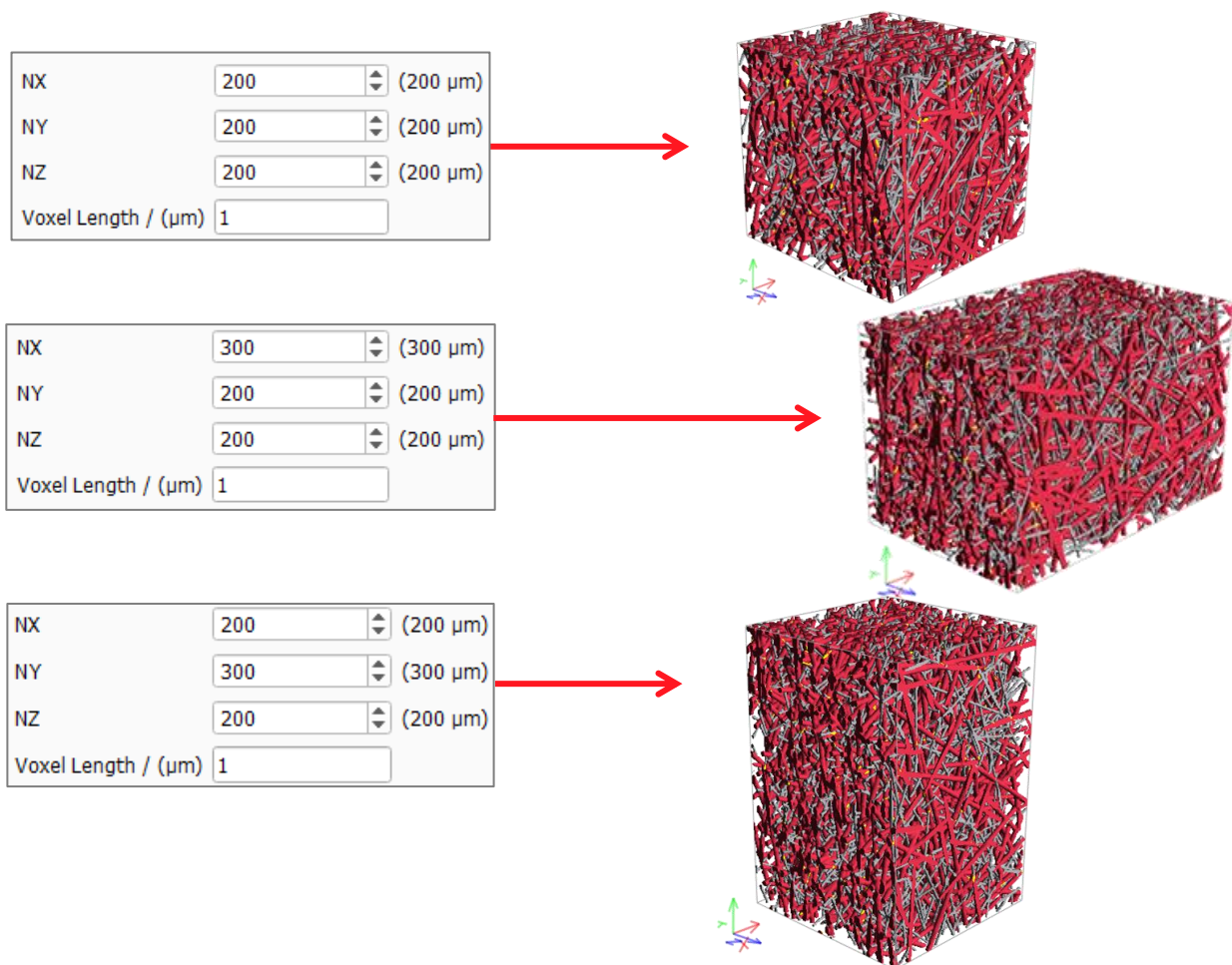

Low values for the voxel length in combination with high values for **NX**, **NY** and **NZ** result in a higher resolution, but also in a higher computational time. After setting the values of **NX**, **NY**, and **NZ**, and **Voxel Length**, the physical structure size is automatically displayed in the chosen units.

Observe how setting the number of voxels at a constant 200 x 200 x 200 voxels ($100 \times 100 \times 100 \mu\text{m}^3$) while decreasing the **Voxel Length** from $0.5 \mu\text{m}$ to $0.25 \mu\text{m}$ has the effect of refining the structure by increasing the resolution while decreasing the size of the volume to $50 \times 50 \times 50 \mu\text{m}^3$.

NX	<input type="text" value="200"/>	(100 μm)
NY	<input type="text" value="200"/>	(100 μm)
NZ	<input type="text" value="200"/>	(100 μm)
Voxel Length / (μm)	<input type="text" value="0.5"/>	

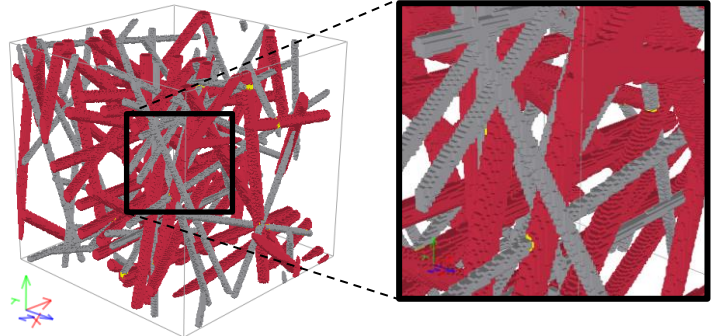

NX	<input type="text" value="200"/>	(50 μm)
NY	<input type="text" value="200"/>	(50 μm)
NZ	<input type="text" value="200"/>	(50 μm)
Voxel Length / (μm)	<input type="text" value="0.25"/>	

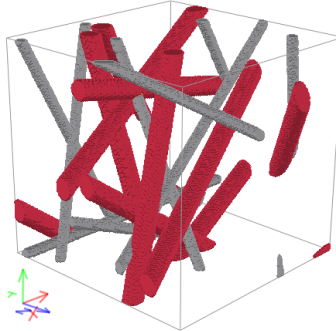

By restoring the original size of the volume to $100 \times 100 \times 100 \mu\text{m}^3$ (**NX**=400, **NY**=400, **NZ**= 400), the structure is displayed at higher resolution.

NX	<input type="text" value="400"/>	(100 μm)
NY	<input type="text" value="400"/>	(100 μm)
NZ	<input type="text" value="400"/>	(100 μm)
Voxel Length / (μm)	<input type="text" value="0.25"/>	

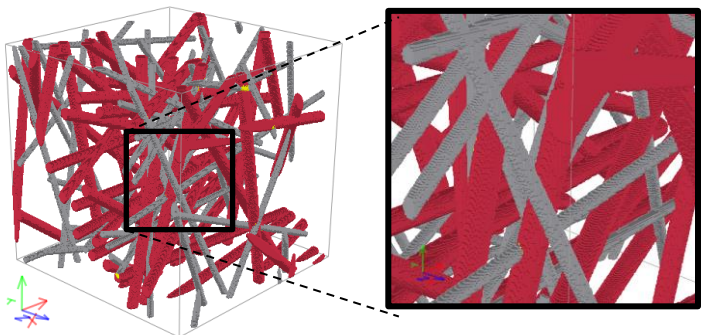

Origin X, Origin Y, and Origin Z, and Center Domain

The **Origin X**, **Origin Y**, and **Origin Z** parameters, together with the **Center Domain** button, determine the placement of the structure in the physical space.

Zero values for Origin X, Origin Y, and Origin Z mean that the point with (0, 0, 0) coordinates is located at the lower left corner of the structure.

Entering values for **Origin X**, **Origin Y**, and **Origin Z** is useful in applications that call for exact structure coordinates.

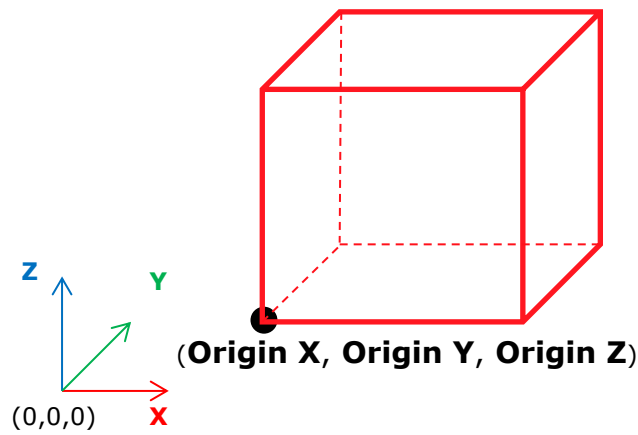

When clicking the **Center Domain** button, the origin (0, 0, 0) is set to the center of the structure.

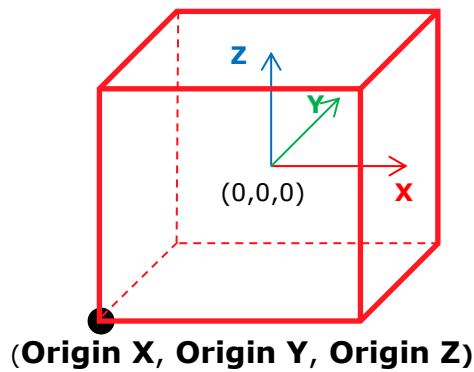

Periodicity

Checking the **Periodic X**, **Periodic Y**, and **Periodic Z** boxes allows the generation of structures which are periodic in one or several directions. Periodicity has the effect that the fibers ending on one side of the volume reappear in the opposite side, so that when several volumes with periodic fibers are combined, the structure emerges as a repetitive complex.

An error message appears if trying to generate a periodic structure with **Infinite fibers**.

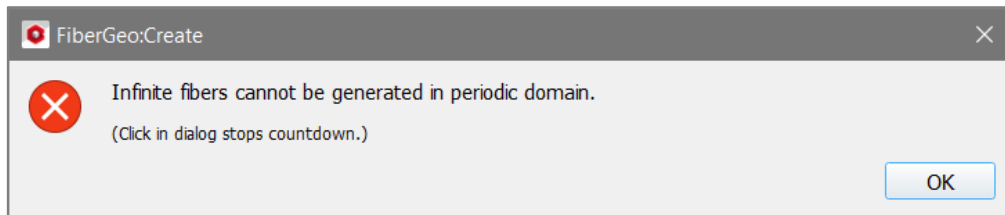

To avoid this error, go to **Fiber Options** and remove the **Infinite** fibers and add a different fiber type, or, alternatively, do not choose to generate with periodicity.

Observe the effect of checking **Periodic X** and **Periodic Y**, but leaving un-checked **Periodic Z**, on the periodicity of a generated fibrous structure.

Domain					
NX	400	(400 μm)	Origin X / (μm)	0	<input checked="" type="checkbox"/> Periodic X
NY	400	(400 μm)	Origin Y / (μm)	0	<input checked="" type="checkbox"/> Periodic Y
NZ	400	(400 μm)	Origin Z / (μm)	0	<input type="checkbox"/> Periodic Z
Voxel Length / (μm)	1		Pore / Matrix Material (ID 00)	<input type="text" value="Air (Fluid) ..."/>	<input type="button" value="Center Domain"/>

View → 3D Rendering

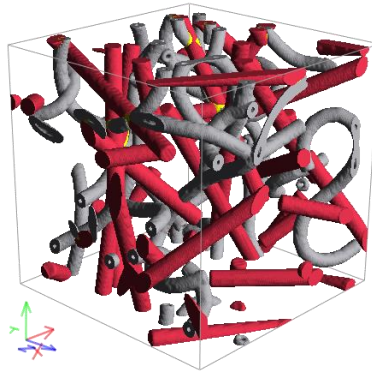

View → 2D Cross Section

Direction X Depth 300 Slice 100	Direction Y Depth 300 Slice 100	Direction Z Depth 300 Slice 100

The effect is readily observed when repeating the sample structure through **Model → ProcessGeo → Crop, Embed & Add Layers** (Repeat: X- 400 voxels, Y- 400 voxels, and Z- 400 voxels) and viewing it again from the three directions.

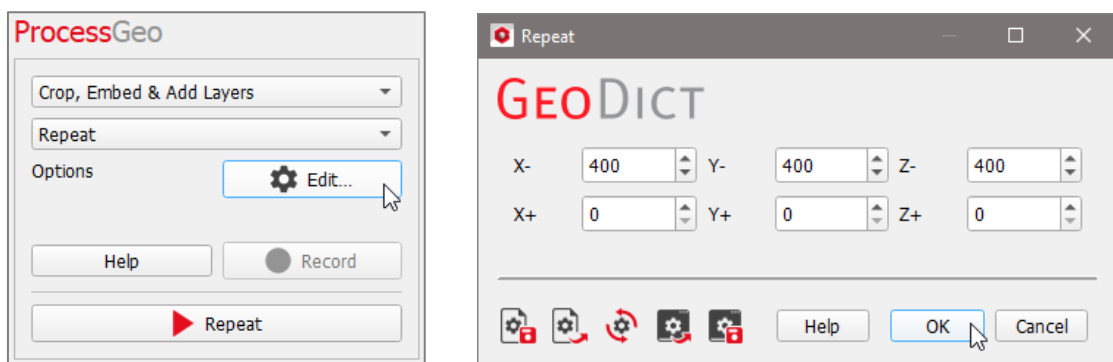

In the directions checked as periodic (X and Y), the fibers connect to each other across the repeated samples. In the direction checked as non-periodic (Z), the fibers end at the edge of the sample.

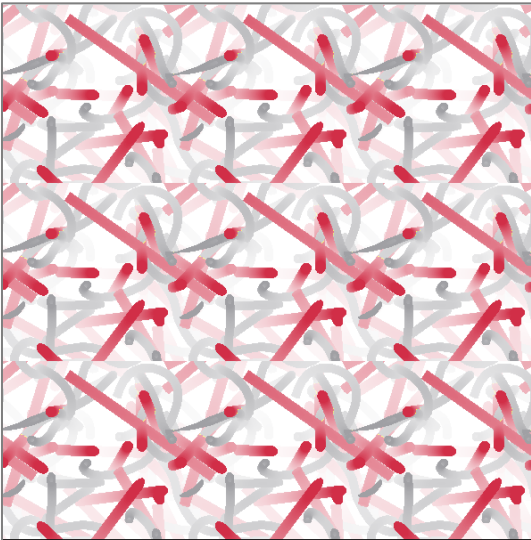

Observe the periodicity in the Y-direction, with unit cells passing smoothly into each other, and no periodicity in Z-direction, with unit cells appearing disconnected.

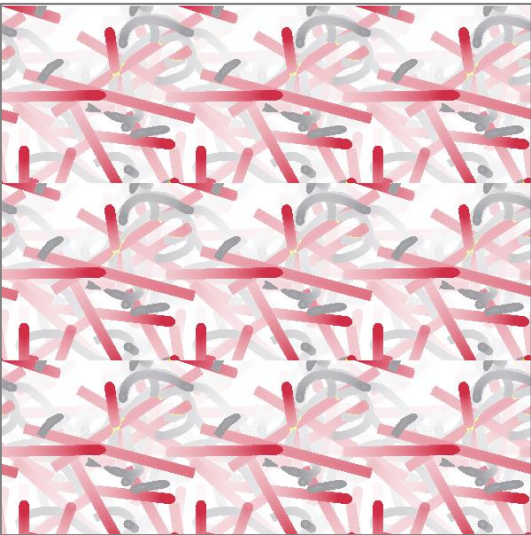
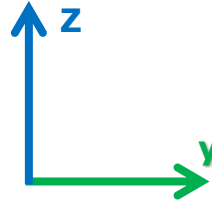

Observe the periodicity in X-direction, with unit cells passing smoothly into each other, and no periodicity in Z-direction, with unit cells appearing disconnected.

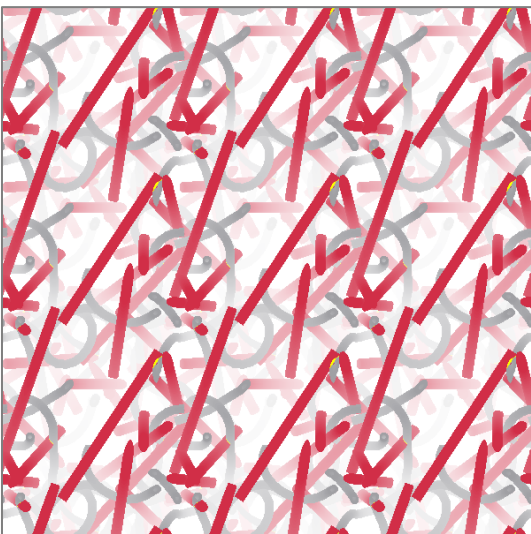
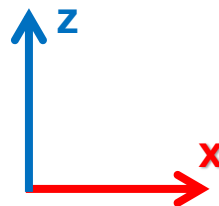

Observe the periodicity in the X- and the Y-directions, with unit cells passing continuously into each other in both directions.

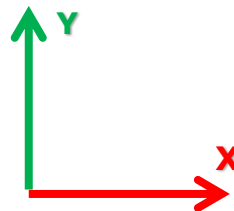

Pore/Matrix Material

Choose the material of the pore space or the matrix around the fibers from the pull-down menu.

When the material is chosen to be **Pore**, the fibers are embedded in empty pore space. Otherwise, the material filling the matrix can be chosen to be a **Solid, Porous** medium, or **Fluid** in which the fibers are embedded.

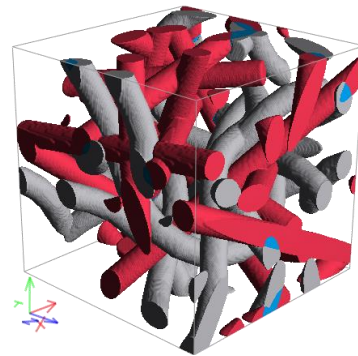
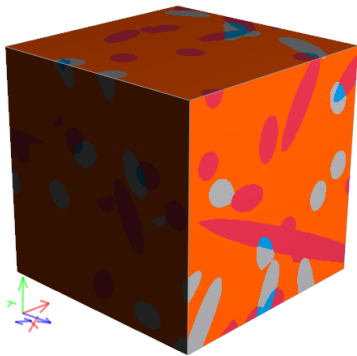
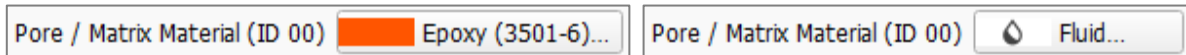

GENERATION AND OVERLAP MODE

The options in the **Generation and Overlap Mode** panel control the relative position among fibers or with the structure currently in memory. It is possible to choose **Allow Fiber Overlap**, **Without (Remove) Fiber Overlap**, **Prohibit Fiber Overlap**, **Use Isolation Distance**, **Match Solid Volume Fraction Distribution**, **Enforce Overlap**.

Allow Fiber Overlap

Fibers may overlap when **Allow Fiber Overlap** is selected.

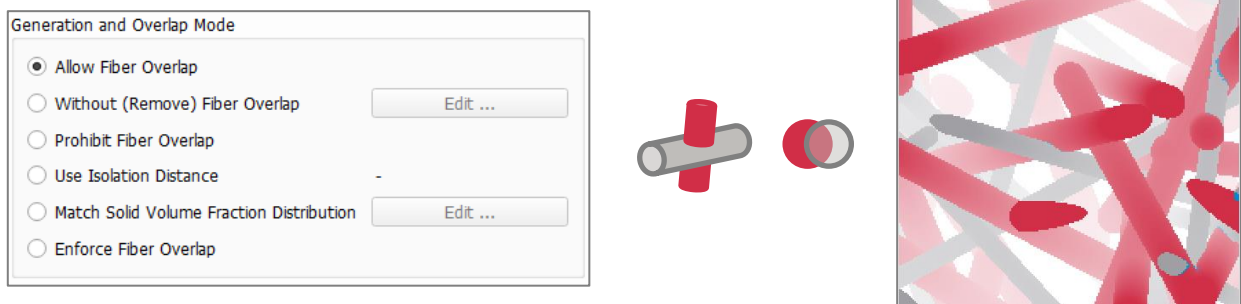

Without (Remove) Fiber Overlap

Checking **Without (Remove) Fiber Overlap** eliminates existing overlaps *after* the generation step. The user should consider that:

- Overlaps can be removed from:
 - Periodic structure models with fiber lengths smaller than the domain size. If fibers longer than the domain size are present in the model, they might overlap with themselves. This type of overlap cannot be removed.
 - Non-periodic structure models with arbitrary fiber length (short or infinite fibers).
- The statistical properties might change slightly.
- The way in which the overlap removal occurs can be controlled through the **Remove Overlap Options** accessible via the **Edit ...** button.

In the **Remove Overlap Options** dialog, the following parameters can be set:

- **Iterations**: Defines after how many iterations the removal stops.
- **Iterations SVP Unchanged**: After this number of iterations, the removal stops if the **SVP** (**S**olid **V**olume **P**ercentage. See page [24](#)) remained unchanged during this period.
- **Overlap SVP / (%)**: Defines the final allowed **Overlap SVP**.
- **Allow Object Shifts**: Check if shifting fibers is an allowed operation for removal. Define the allowed **Number of Shifts** per iteration and the maximal **Shift Distance** per iteration. The fibers will be shifted in all directions.
- **Allow Object Rotations**: Check if rotating the fibers should be an allowed operation for overlap removal. Define the maximal **Number of Rotations** allowed per iteration. Objects will be rotated in all directions, where the maximal rotation angle per iteration is one degree.

- **Allow Fiber Deformations:** Check if bending the fibers should be an allowed operation for overlap removal. Define the **Maximal Bending Angle** allowed between two segments. Each fiber consists of several segments. The center points of the segment connections are shifted in all directions, while the other shape parameters, as e.g. fiber length and segment length are kept constant. The maximal point shift distance is the same as for the object shift.

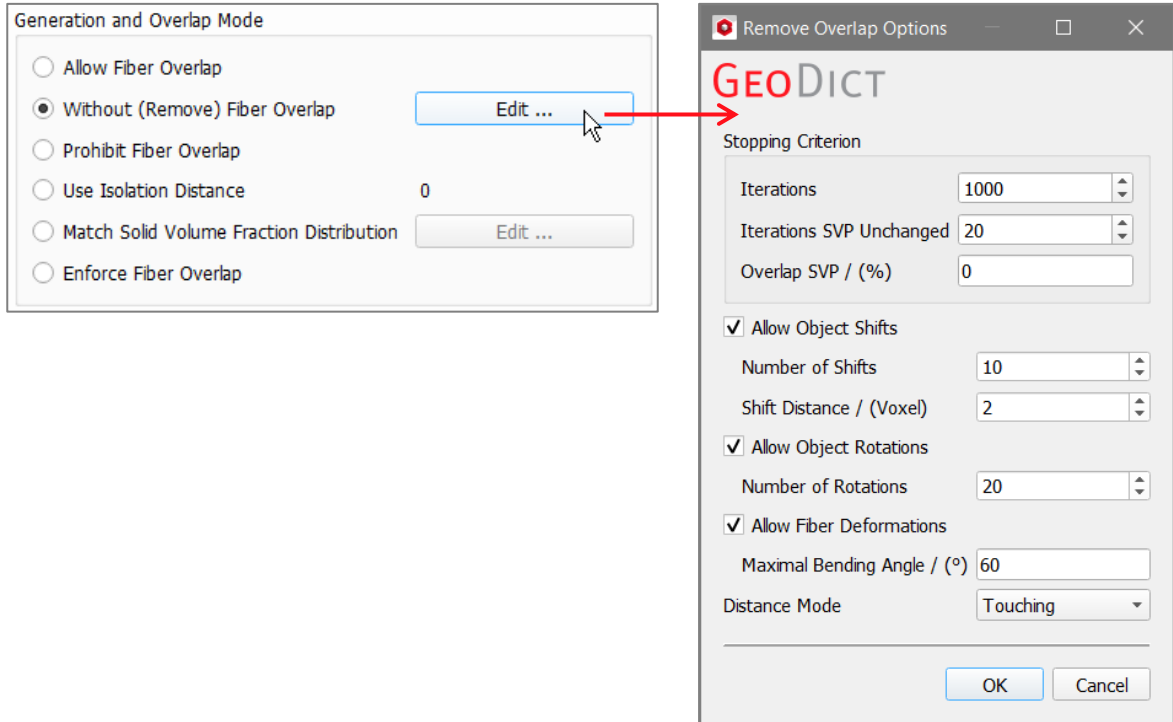

- **Distance Mode:** The pull-down menu offers four options:
 - The fibers can be **Touching** (distance zero).
 - Enter a maximal **Defined Overlap** allowed for the fibers.
 - Enter a minimal **Defined Isolation** distance for the fibers.
 - **Avoid Contacts** means a defined isolation of one voxel volume diagonal.

In a periodic domain, fibers which are longer than the domain might overlap themselves. This type of overlap cannot be removed. In this case, a message appears.

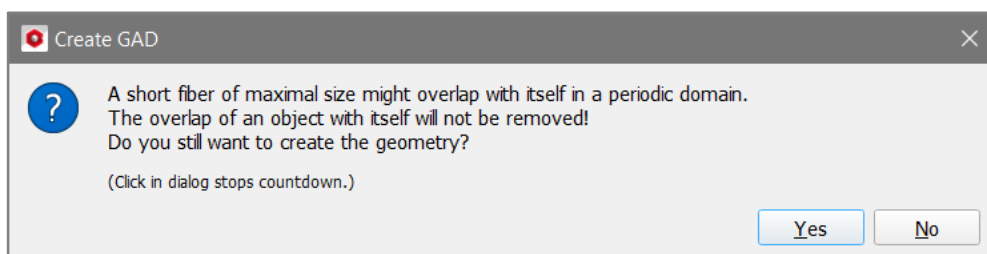

Prohibit Objects Overlap

Fibers may touch but not overlap when **Prohibit Objects Overlap** is selected.

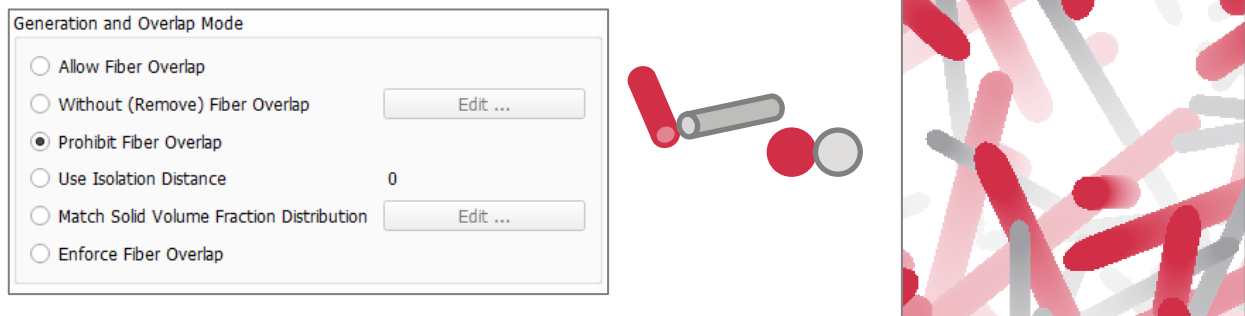

In this case, the overlap of the fibers is prohibited *during* the creation process. This option might lead to longer run times compared to **Remove Objects Overlap**. It only works for low porosity. As before, fibers longer than the domain might overlap themselves if a periodic domain is selected.

Use Isolation Distance

If a positive value is inserted for **Use Isolation Distance**, the gaps between fibers have at least this preset distance.

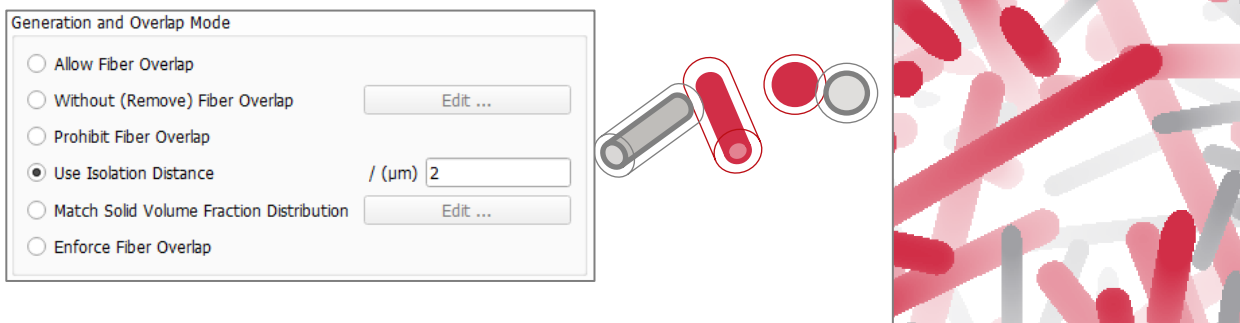

When **Use Isolation Distance** is set to negative values (e.g. $-10 \mu\text{m}$), the effect is that the fibers may overlap with maximally $10 \mu\text{m}$ (showing in a different color which here is blue). Negative values of isolation distance are useful to model synthetic fibers that melt, or natural fibers that deform at touching points, during the generation of the structure. Then, the distance between the centers of the fibers is less than the sum of the two radii.

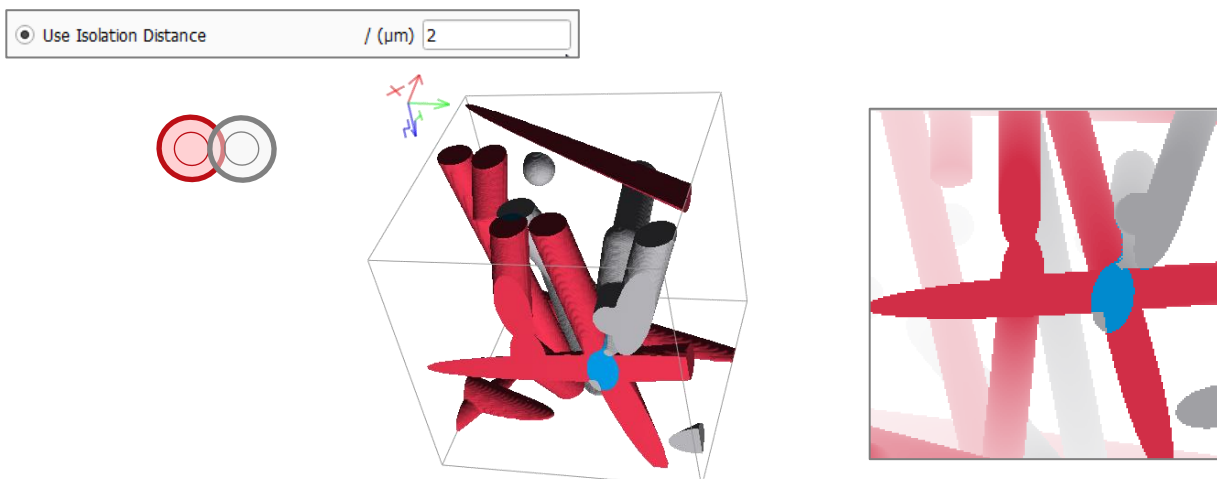

Match Solid Volume Fraction Distribution

For certain applications it is necessary to create statistically distributed inhomogeneities, e.g. to generate a bimodal distribution of a fiber network. The **Match Solid Volume Fraction (SVF) Distribution** command allows to create such structures with an inhomogeneous solid volume distribution. Fibers are shifted and rotated to optimally match a SVF distribution given by a Gaussian random field. This takes place *after* the generation step. The user should consider that:

- Periodicity is checked automatically for all directions. This is a prerequisite for the **Match Solid Volume Fraction** algorithm.
- Using this feature, overlap cannot be removed during structure generation.
- As the SVF distribution is matched after generating the fibers fitting the Stopping Criterion (page [23](#)), the resulting values can differ from the inserted parameters for the Stopping Criterion. This is because the fiber structure is generated with overlap and the amount of overlap can change when fibers are shifted.
- The distribution for **Center** defined in the **Fiber Options** tab will also be affected strongly by matching the SVF distribution after generating the fiber structure with the specified center distribution. The difference between the **Center Distribution** and the **Match SVF Distribution** is explained on page [20](#).
- It is recommended to generate the structure without inlet and outlet to use this algorithm. Otherwise, the fibers will be also moved to these empty spaces. If desired, add inlet and outlet either with **GadGeo - Edit Domain** to avoid cropped fibers (see the [GadGeo](#) handbook of the User Guide) or with **ProcessGeo -Embed** (see the [ProcessGeo](#) handbook of the User Guide).
- It is possible to reuse an existing stochastic field describing the desired SVF distribution. For this, first generate the fiber structure with the mode **Allow Overlap** and then use the corresponding algorithm in **GadGeo**. Open the **GadGeo** section by selecting **Model** → **GadGeo** from the menu bar. Select **Algorithms** from the first pull-down menu and then **Match SVF Distribution** from the second. How to use this algorithm is described in the [GadGeo](#) handbook of the User Guide .
- For large structures, the feature needs a large amount of memory as a volume field is loaded in **GeoDict** additional to the structure file.

The SVF distribution can be controlled through the **Match SVF Distribution** dialog accessible via the **Edit ...** button.

In the **Match SVF Distribution** dialog, the following parameters can be set:

- **Stopping Criterion:** Define the **Error Bound** to determine when the SVF matching should be stopped. In every step for each fiber segment a force is computed to shift the fiber segment. When the normalized relative change of solid volume fraction is smaller than the given error bound, the algorithm is stopped.
- **Distribution Coarsening Factor:** The SVF distribution is matched using a coarser version of the created Gaussian random field.

The value must be small enough to resolve the heterogeneity of the structure. A larger value leads to a shorter runtime.

If the **Distribution Coarsening Factor** is set to 1, the Gaussian random field is generated with the same resolution as the fiber structure.

For a fiber structure with a domain size of 2048x1024x512 voxels and a voxel length of 1 μ m, a coarsening factor of 32 leads to a random field of 64x32x16 voxels with a voxel length of 32 μ m.

To resolve the correlation length with a whole number of voxels, the value should be chosen as a divisor of the correlation length, which in turn is recommended to be a divisor of the domain size. For example, if the correlation length is set to 128 voxels and the coarsening factor is set to 32, $128/32 = 4$ voxels remain to resolve one feature of the random field.

- **Distribution Mode:** For distribution, select **Gauss** or **Gradient** from the pull-down menu. The following parameters are different for these two options.

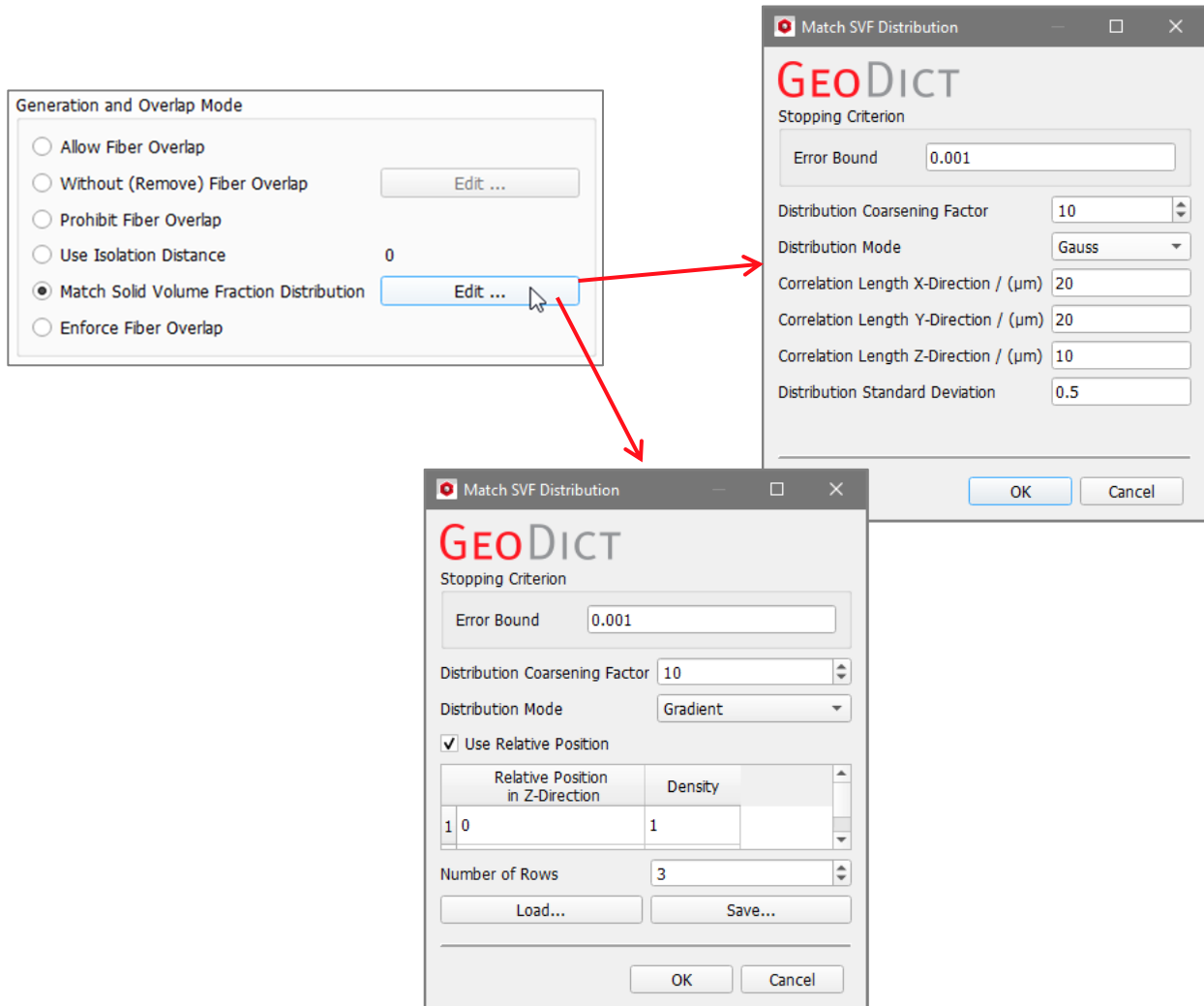

Gauss:

- **Correlation Length:** The correlation length is a measure for the inhomogeneity of the material. The parameters for **X-**, **Y-** and **Z-Direction** determine the correlation length of the Gaussian random field, which defines the SVF distribution. It is recommended to select a divisor of the domain size in the corresponding direction. For a constant SVF in one direction choose the corresponding domain size as correlation length.
- **Distribution Standard Deviation:** Define the relative standard deviation of the created SVF distribution. A larger value leads to a larger difference between the regions of low and high density. Note, that the mean value is fixed at 0.

Gradient:

- **Use Relative Position:** If checked, the left column values from 0 to 1 correspond to locations in the structure. In the Z-direction, the value 0 is at the origin and the value 1 is at end of the domain. If not checked the values in the left column correspond to absolute values in the given unit.
- **Density Distribution:** The right column assigns relative density values at the locations defined in the left column, e.g. the value 10 means that there are five times more fibers at $Z = 1$ than at $Z = 0.1$, with a density value of 2.

The fiber density increases and decreases smoothly between the given locations in the Z-direction.

<input checked="" type="checkbox"/> Use Relative Position	
Relative Position in Z-Direction	Density
1 0.1	2
2 1	0.1
Number of Rows <input type="text" value="2"/>	

- **Number of Rows:** The number of rows in the density distribution can be increased or decreased to enter as many pairs of position and density as desired.
- **Load/Save:** The density distribution can be saved to and loaded from a .txt file.

In the following example curved fibers are generated in a domain of 600x600x100 μm . For the first structure **Allow Fiber Overlap** is checked and no SVF distribution is matched. The structure of the second picture was generated with the same parameters except for matching the SVF distribution shown below.

Allow Fiber Overlap

Match Solid Volume Fraction Distribution

Edit ...

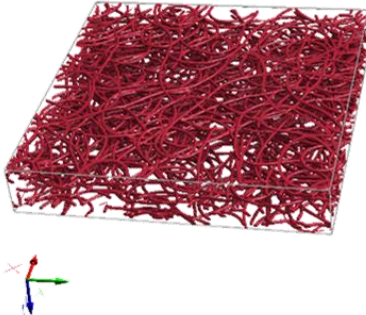

Match SVF Distribution

GEODICT

Stopping Criterion

Error Bound

Distribution Coarsening Factor

Distribution Mode

Correlation Length X-Direction / (μm)

Correlation Length Y-Direction / (μm)

Correlation Length Z-Direction / (μm)

Distribution Standard Deviation

OK Cancel

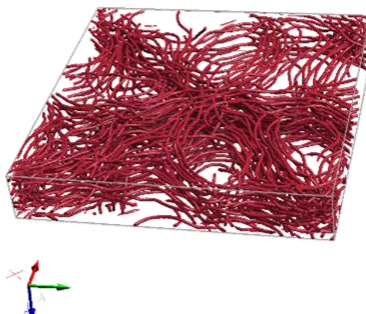

A volume field describing the used gaussian random field is saved in the result folder after generating a fiber structure matching an SVF distribution. Select **File** → **Load Volume Field ...** from the menu bar to load it or choose the **Data Visualization** tab in the **Result Viewer** of the result file (*.gdr) and click **Load *.gvf**.

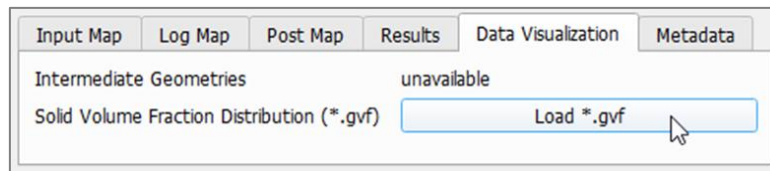

For the above example, the resulting gaussian random field is shown in 2D view from all three directions.

Viewed from X-direction a high correlation in Z-direction is observed, as the structure size in this direction equals the **Correlation Length Z**.

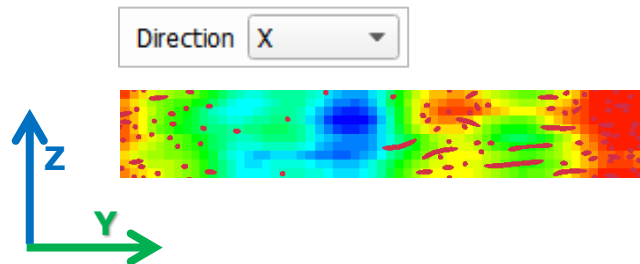

In Y-direction a more inhomogeneous SVF distribution was generated, as the structure size in Y-direction is 12 times higher than the **Correlation Length Y**.

Viewed from Y-direction a similar observation can be obtained. Still the distribution in Z-direction is very homogeneous, whereas it has low correlation in X-direction.

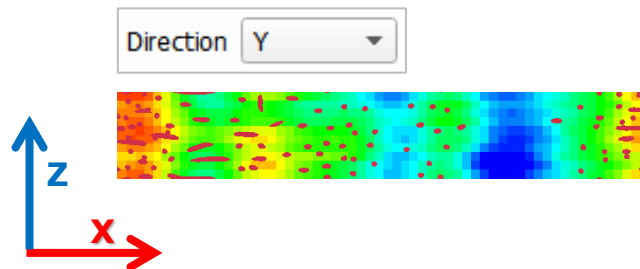

From Z-direction, the structure is very inhomogeneous, due to small **Correlation Length** values for **X** and **Y** (50µm) compared to the structure size in these directions (600µm).

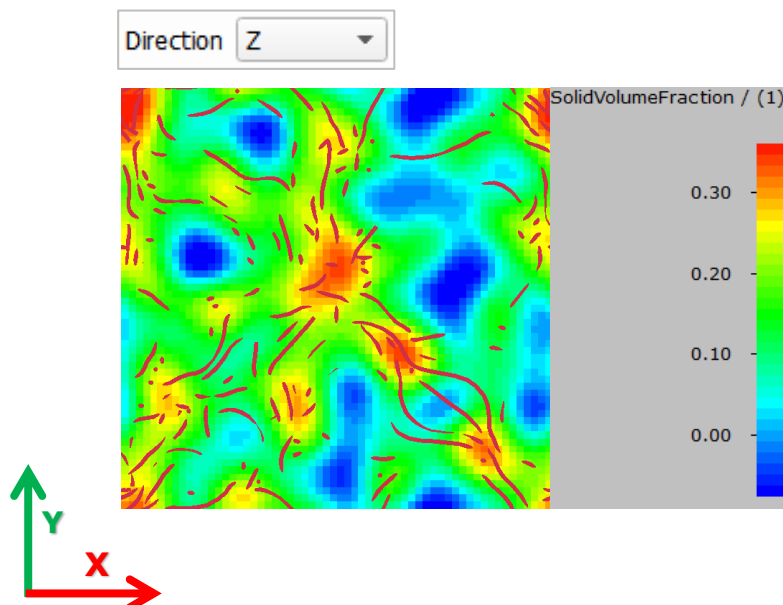

In the following example observe how the fibers are distributed corresponding to the given density distribution.

The fibers in the first example have the highest density in the center of the Z-axis. Towards both ends of the domain in Z-direction the fibers become fewer. This corresponds to the **Density** values 0 for the relative positions $Z=0$ and $Z=1$ and a density of 1 for the relative position $Z=0.5$.

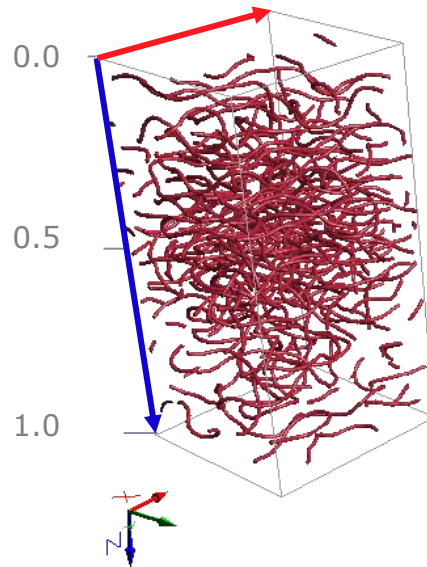
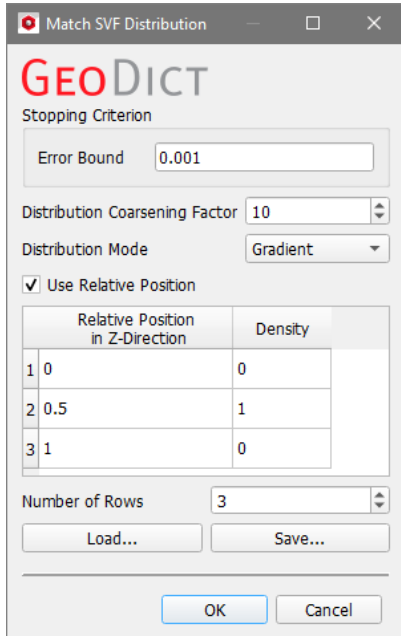

The second example shows a density distribution in Z-direction with 4 rows. A density of 20 for position $Z=0$ leads to twice as many fibers near the top as fibers in the lower third with a density value of 10 for position $Z=0.7$. Towards the center and the bottom, the fibers become fewer for a density value of 0.

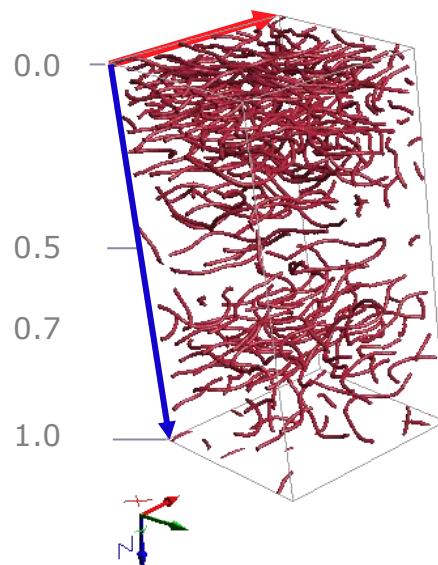
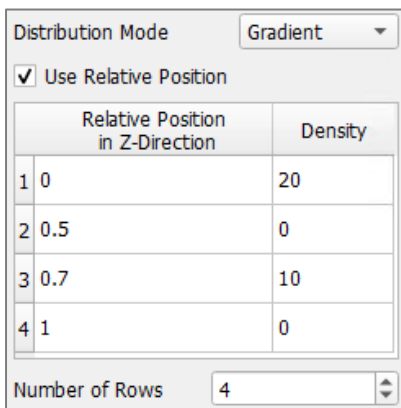

This feature is different from the **Density Distribution for Center** (See **Fiber Options**, page 62). The Match SVF Distribution is a post-processing step, and the fibers are moved until they match the given solid volume fraction distribution.

For the center distribution, the fiber centers are placed according to the given distribution, which is much faster and does not change the orientation of the fibers

but leads to a different solid volume fraction distribution and the distribution is not as smooth as with **Match SVF Distribution**.

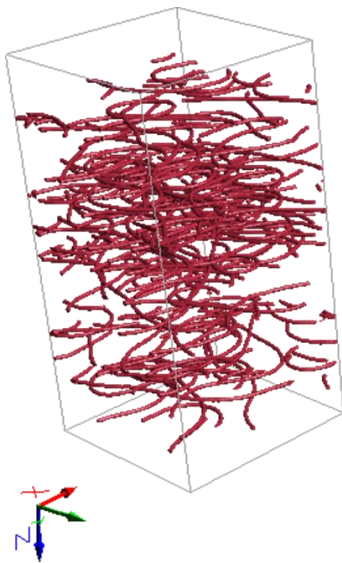

Center Distribution

<input checked="" type="checkbox"/> Use Relative Position		
	Relative Position in Z-Direction	Density
1	0	0
2	0.5	1
3	1	0

Number of Rows

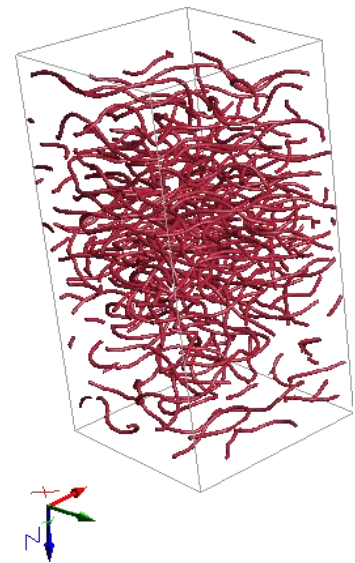

SVF Distribution

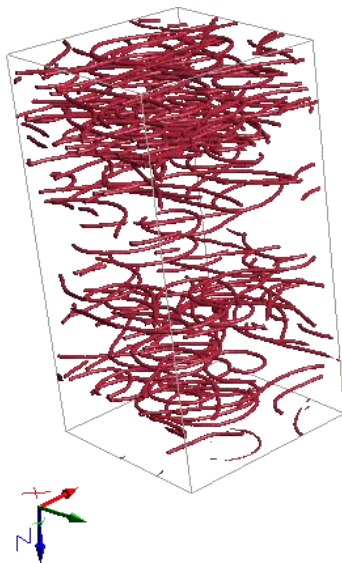

<input checked="" type="checkbox"/> Use Relative Position		
	Relative Position in Z-Direction	Density
1	0	20
2	0.5	0
3	0.7	10
4	1	0

Number of Rows

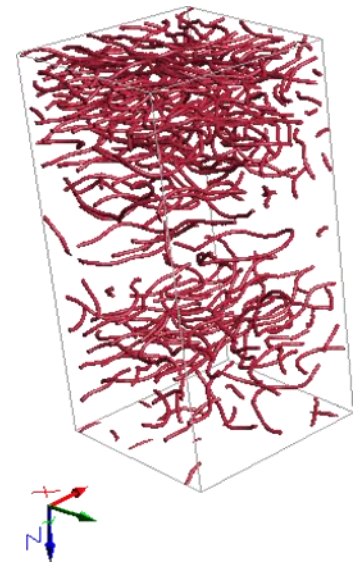

Prohibit Overlap with Current Structure

If checking **Create in Current Domain** (see page [5](#)), **Prohibit Overlap with Current Structure** appears instead of Match SVF Distribution. The fibers in the newly generated structure can intersect with each other but not with those of the already existing structure.

Observe this effect in a structure with one fiber (red) over which a new structure with thinner grey fibers is generated. Whereas the grey fibers overlap with each other, they do not overlap with the red fiber.

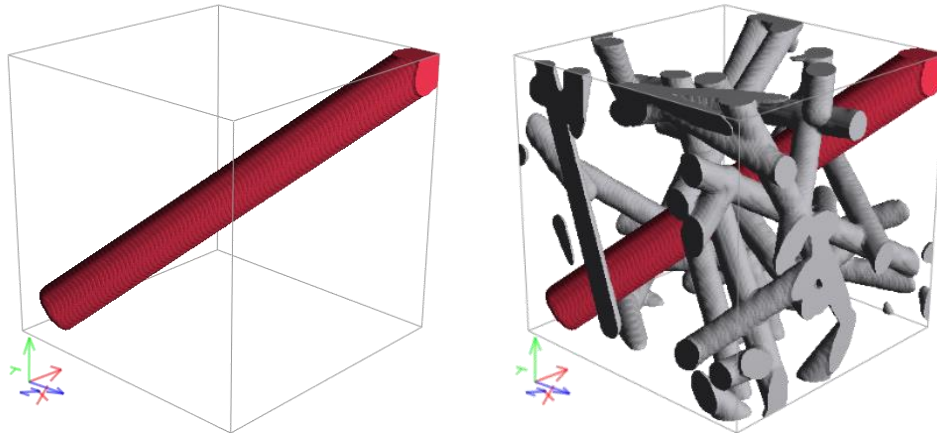

Enforce Fiber Overlap

The structure's fibers are required to join each other, forming a large, connected component. This effect is obvious when the structure's solid volume percentage is low (here 10%), i.e. the fibers do not already form a connected component.

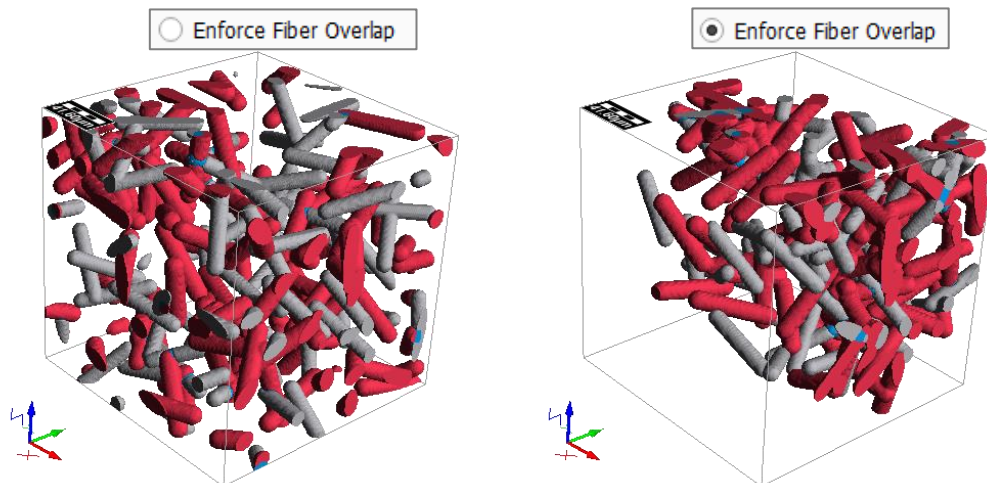

The algorithm under **Allow Objects Overlap** is fast, especially for big structures and, in most cases, leads to excellent results.

If the user chooses **Use Isolation Distance** or **Remove Objects Overlap**, the generation time may be longer when generating structures with high solid volume percentages.

Prohibit Objects Overlap or **Prohibit Overlap with Current Objects** may be unfeasible when generating very dense structures.

For filtration and flow simulations, which occur in the pore space, overlap should be allowed when generating structures (in general).

For the simulation of conductivity or mechanical properties, which occur in the solids, overlap should be removed, or structures without overlap should be generated.

STOPPING CRITERION

The parameters in the **Stopping Criterion** panel control whether the generation process should be continued, or the material is “ready”.

The available parameters are **Fixed Object Number**, **Object Solid Volume Percentage (%)**, **Grammage (g/m²)**, **Density (g/cm³)**, or **Object Weight Percentage (%)**.

Additionally, when the **Maximal Run Time (h)** is expired, the process is stopped even when the desired parameter cannot be achieved.

When **Grammage**, **Density** or **Object Weight Percentage** are chosen as stopping criterion, the temperature must be set as additional parameter.

In those cases, the **Thermal Expansion Coefficients** of the materials are included in the calculation. It is defined in the **Material Database** under the **Mechanical Properties** tab.

When choosing **Fixed Object Number** or **Object Solid Volume Percentage**, the **Temperature** parameter is not available.

Fixed Object Number

When **Fixed Object Number** is chosen as stopping criterion, FiberGeo places the given number of fibers in the structure and then the generation stops.

Observe the effect of setting a fixed number of objects (20, 100, or 500) as stopping criterion, for the generation of a structure with two fiber types. All other parameters are left untouched, including the default **Allow Fiber Overlap**. Note how the overlapping of fibers, shown in blue, increases with the number of objects present in the structure.

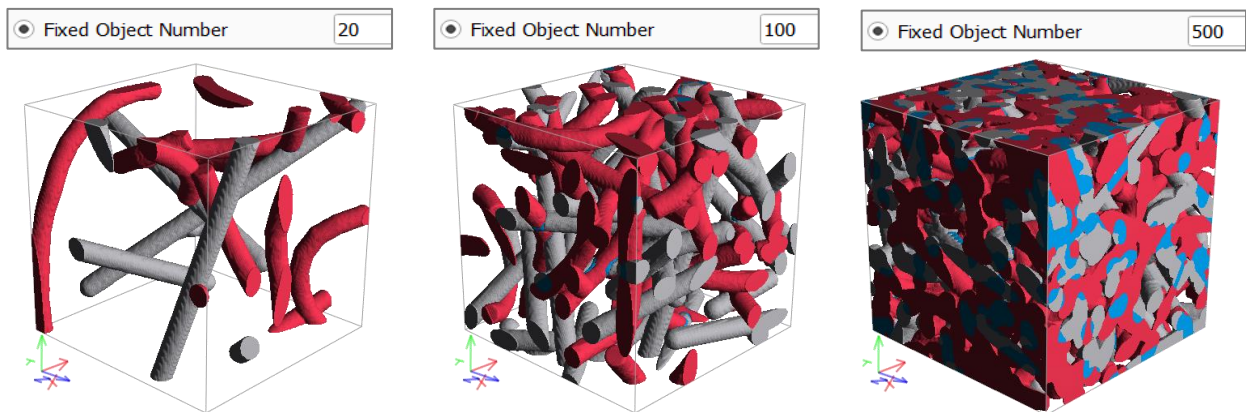

Object Solid Volume Percentage

The **Object Solid Volume Percentage (SVP)** determines the fraction of the total volume in percent that the fibrous structure should have. Accepted values range from 0 to 100%. For example, a structure with an **Object Solid Volume Percentage** of 40 consists of 40% fibers and 60% void space. Porosity is defined as $1 - \text{SVP}/100$.

Observe the difference in a structure when varying the solid volume percentage from 5%, to 20% and finally to 40%, while all other parameters are left unchanged.

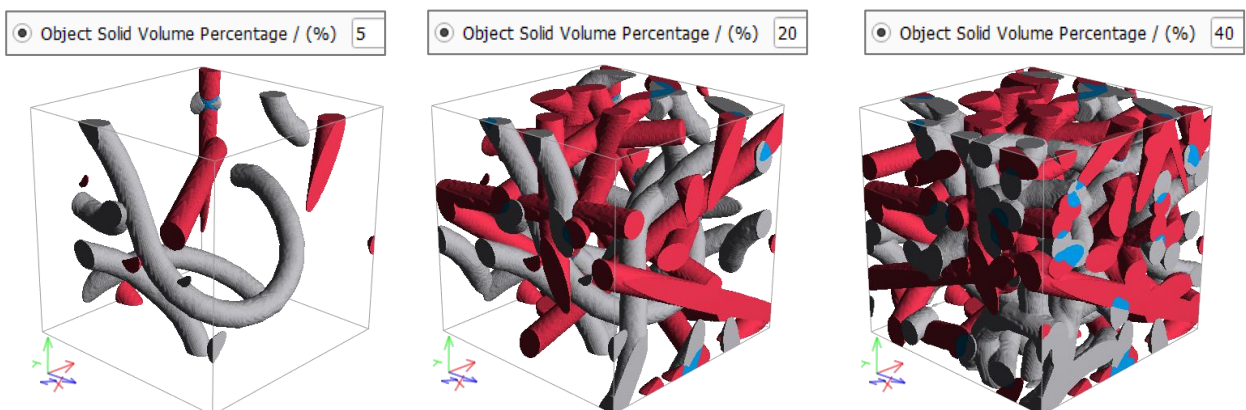

Grammage

The **Grammage** (g/m^2) determines the mass per unit area (in the XY-Plane) of the resulting fibrous structure. The mass is commonly called weight. When **Grammage** is chosen as stopping criterion, the **Density** (g/cm^3) of the fiber material(s) must be defined for each fiber type and chosen material in the fiber panels under the **Fiber**

Options tab and the temperature has to be set in the **FiberGeo Create Options** dialog.

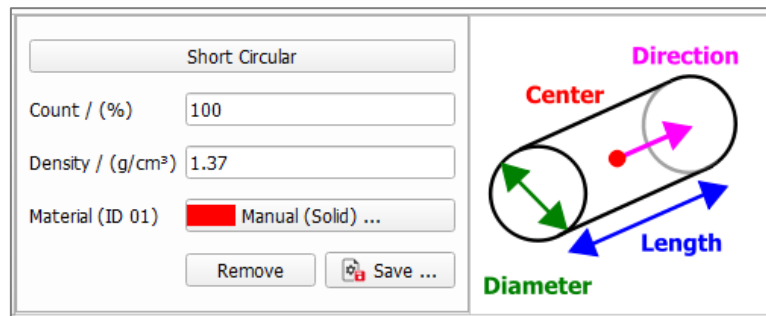

Observe the effect of increasing the **Grammage** from 15 g/m² to 40 g/m², whereas all other parameters are left unchanged.

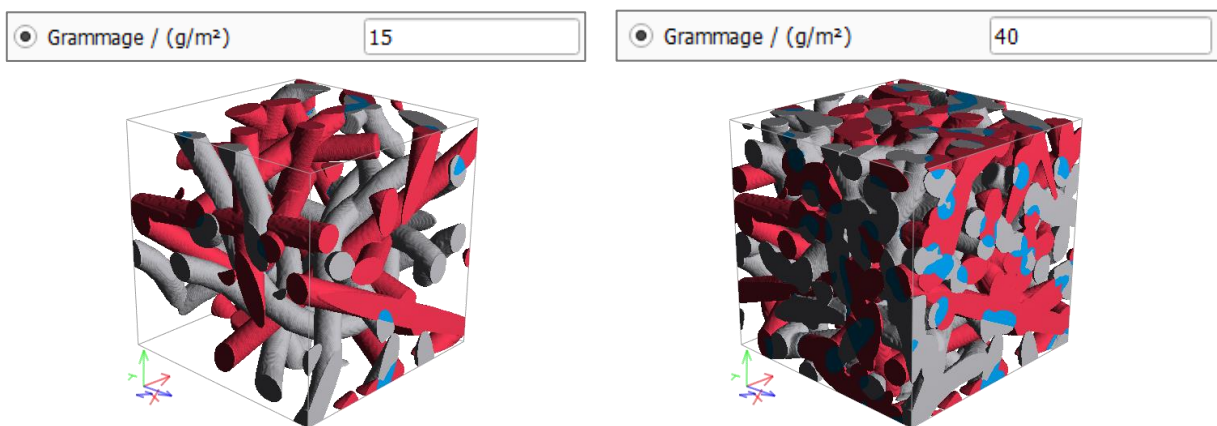

Density

The **Density** of the complete resulting structure depends on the densities of the constituent materials. In the following simple example, the **Matrix Density** is 0 (for Air), and the two fiber materials have densities of 1.0 g/cm³ and 3.1 g/cm³. The **Density** is set to values of 0.10 g/cm³ and to 0.25 g/cm³. The **Density** value cannot be set smaller than the lowest occurring density (here, 0 g/cm³) or larger than the highest occurring density (here, 3.1 g/cm³).

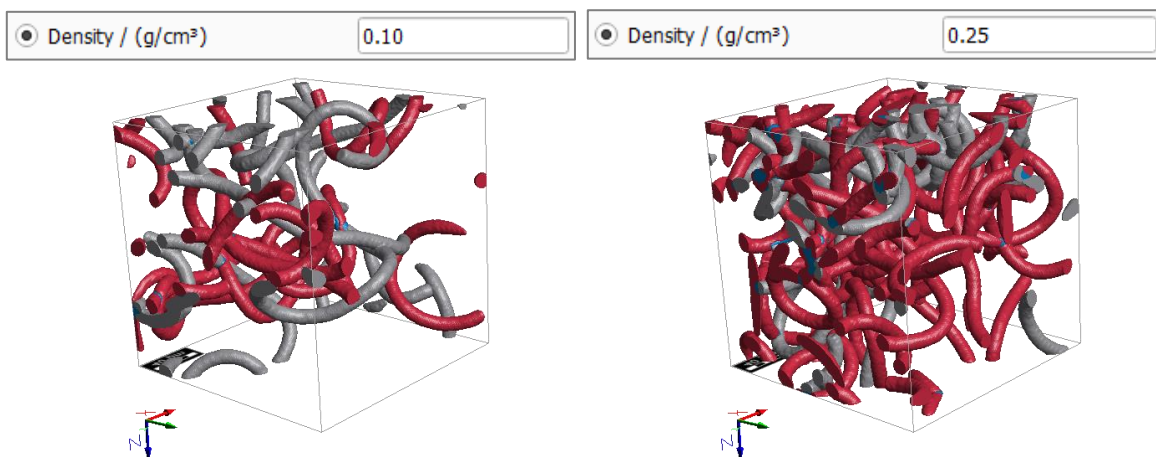

Object Weight Percentage

The **Object Weight Percentage** determines the weight of the fibers in relation to the weight of the whole structure. The calculation is only possible when the **density** of the **Pore / Matrix Material** is greater than zero. Otherwise, an error message will appear.

The screenshot shows the software's configuration window. In the 'Domain' section, 'Matrix Density / (g/cm³)' is set to 1.265. In the 'Stopping Criterion' section, 'Object Weight Percentage / (%)' is set to 10. Other parameters include 'Pore / Matrix Material (ID 00)' set to 'Epoxy (3501-6) (Solid) ...' and 'Maximal Run Time / (h)' set to 6.

The relationship of the variables **Fixed Object Number**, **Object Solid Volume Percentage**, **Grammage**, and **Density** can be observed in the Result Viewer under the Results tab. If the density of the **Pore / Matrix Material** is greater than zero, also the **Object Weight Percentage** appears under the Results - Report tab.

In this example, a **Density** of about 0.1 g/cm³ corresponds to a **Fixed Object Number** of 44, a **SVP** of 3.89% and a **Grammage** of 20.07%.

The screenshot shows the 'Results' tab with the 'Report' sub-tab selected. A table titled 'Absolute object distribution:' is displayed. The 'Total' row is highlighted with a red box. Below the table, it indicates 'Stopping criterion error: 0.37 %'.

	Count	Volume / (%)	Grammage / (g/m ²)	Density / (g/cm ³)	Weight / (%)
Total	realized: 44 target: --- error: ---	realized: 3.89 target: --- error: ---	realized: 20.07 target: 20.00 error: 0.07	realized: 0.1004 target: --- error: ---	realized: 0.00 target: --- error: ---
Object type 1	realized: 44 target: --- error: ---	realized: 3.89 target: --- error: ---	realized: 20.07 target: --- error: ---	realized: 0.1004 target: --- error: ---	realized: 0.00 target: --- error: ---

Maximal Run Time

The **Maximal Run Time** (h) becomes important when generating complex structures with elevated solid volume percentage. When **Prohibit Objects Overlap** has been checked, the required number of fibers in the structure may become unattainable. In that case, the structure generation is stopped after the time entered in **Maximal Run Time** has passed and the achieved structure is considered as the result. The analysis of the GDR result file shows the disparity between the achieved result values and the desired ones.

RANDOM SEED

Random Seed initializes the random number generator behind the structure generator. Changing its value produces different sequences of random numbers and hence, different realizations of the specified structure. If all settings are equal, generating with the same **Random Seed** value produces exactly the same structure, as shown by the **Structure ID** number in the Status section. **Random Seed** is a non-negative integer number.

Varying the **Random Seed** allows generating different samples of the same fibrous structure for a series of experiments. In the following examples, all parameters are unchanged while the random seed automatically increases with every generation run (45, 46 and 47).

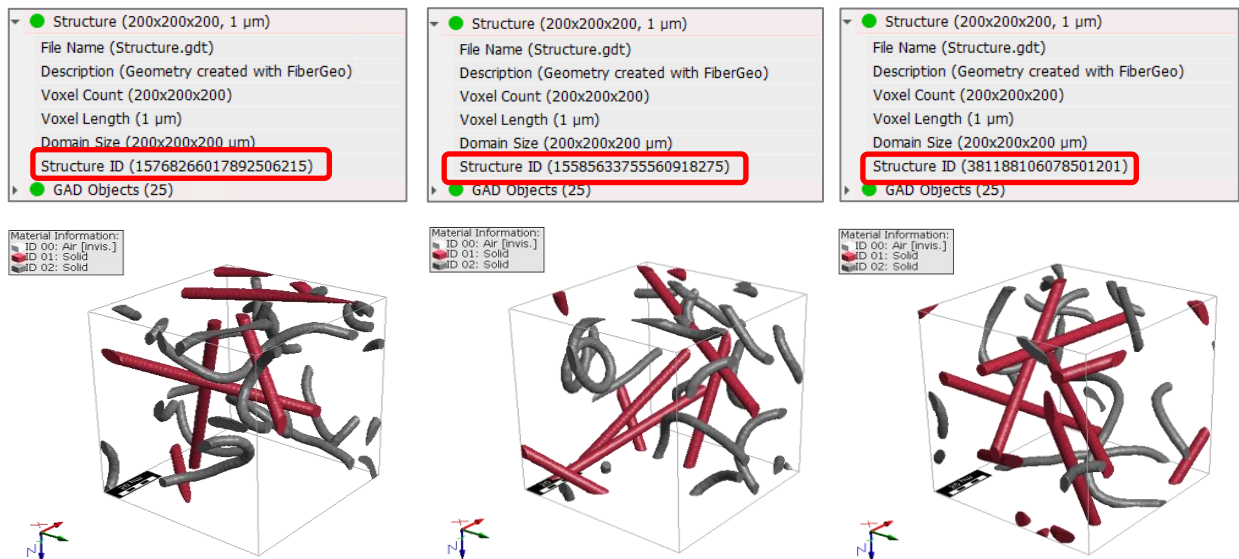

FIBER OPTIONS

All fiber options listed here can be separately set for each fiber type. Up to eight different object types may be added to the same structure.

The fibers available for the generation of fibrous structures are organized and listed in panels. For all fibers, the left column of the panel contains the name of the fiber type, the fiber **Percentage** in the structure as **Count**, **Volume**, or **Weight**, and the fiber **Material**. Fiber types can be discarded when clicking **Remove** in the left panel for that fiber type or can be saved as predefined object using the **Save...** button.

The middle column shows a schematic drawing of the main geometrical properties of this fiber type. In the right column, the geometrical properties or defining parameters of the fiber type can be entered. These geometrical properties include diameter, orientation, length, position, longitudinal deformation parameters (curved fibers), etc.

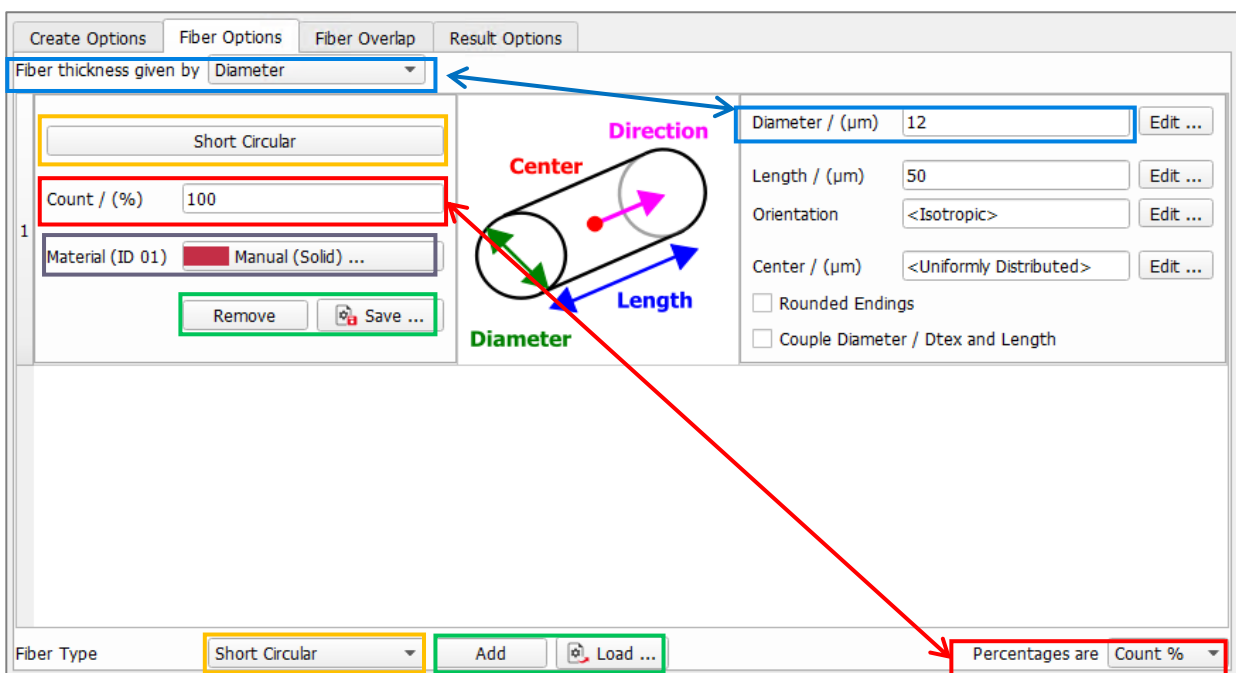

Infinite Circular is the default **Fiber Type**. At the bottom left of the dialog, clicking **Add** inserts other fiber types chosen from the **Fiber Type** pull-down menu (Short Circular, Curved Cellulose, Infinite Hollow, etc.). Previously saved fiber types with individually defined parameters can be loaded via the **Load...** button.

Clicking on the fiber type name minimizes the object panel, and clicking on it again when minimized, expands it.

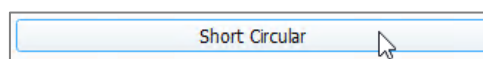

A scroll bar at the right allows to navigate up and down in the list of chosen fiber types.

FIBER THICKNESS GIVEN BY DIAMETER OR DTEX

Whether the Fiber Thickness is given by **Diameter** or **Dtex** (decitex: textile unit of measure of fiber weight, 1 Dtex= 1 g/10000 m) is chosen from the pull-down menu, the fiber parameters in the panels are automatically adjusted depending on this choice.

The use of **Dtex** requires knowing the material density in g/cm³.

If the choice of **Fiber thickness given by** is changed, all fields are automatically recalculated.

Fiber thickness given by: Diameter

Infinite Circular

Count / (%) 100

Material (ID 01) Manual (Solid) ...

Remove Save ...

Diameter / (µm) 10 Edit ...

Orientation <Anisotropic Direction> Edit ...

Unless changed, a default density value is used when Dtex is chosen in the pull-down menu.

Fiber thickness given by: Dtex / (g/10000 m)

Infinite Circular

Weight / (%) 100

Density / (g/cm³) 2.58

Material (ID 01) Manual (Solid) ...

Remove Save ...

Dtex / (g/10000 m) 1.076 Edit ...

Orientation <Anisotropic Direction> Edit ...

FIBER TYPE PERCENTAGE AS COUNT, VOLUME, OR WEIGHT

The fiber type **percentage** can be specified as **Count %**, **Volume %** and **Weight %** as selected from the pull-down menu at the bottom right of the dialog.

Fiber thickness given by: Diameter

Infinite Circular

Weight / (%) 100

Density / (g/cm³) 2.58

Material (ID 01) Manual (Solid) ...

Remove Save ...

Diameter / (µm) 10 Edit ...

Orientation <Anisotropic Direction> Edit ...

Fiber Type Short Circular Add Load ...

Percentages are Weight %

Note that, if the **Weight** option is chosen, the material density is needed even when **Diameter** is selected in the **Fiber thickness given by** pull-down menu.

MATERIAL

Material sets the material assigned to the fiber type. The pull-down menu gives access to selecting the desired material from the **GeoDict** Material Database. When none of the materials available in the database fits the preferred specifications, **Manual** should be chosen.

Alternatively, new materials can be defined in **GeoDict's** material database (Click **Edit Material Database...**). See the [Material Database](#) handbook of the User Guide for more information.

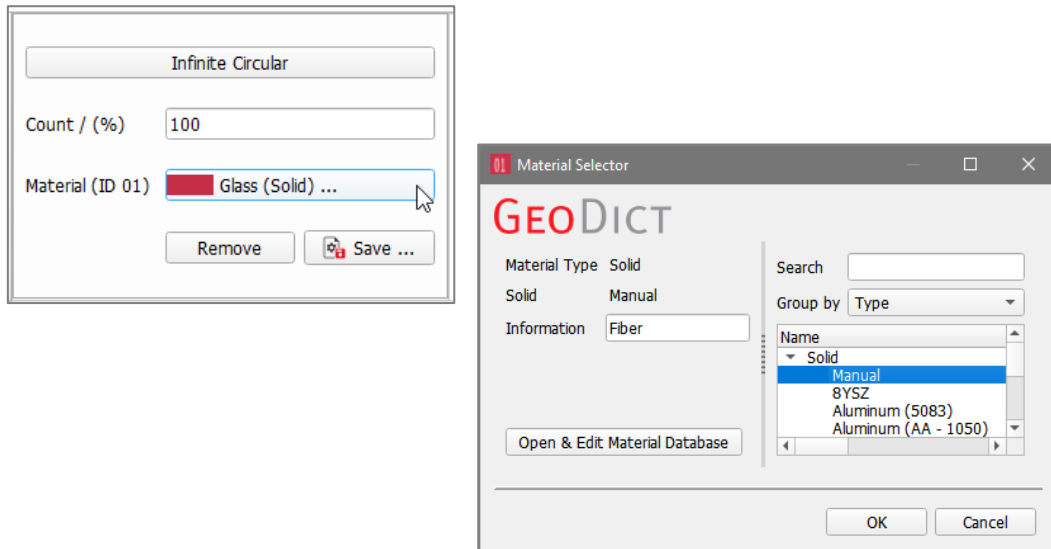

To match realistic material colors for visualization in a certain application, or to make the constituting materials easier to distinguish, the default **Material** colors can be changed through the **Color & Visibility** tab from the side bar on the right-hand side of **GeoDict**. For more information about Visualization Settings see the [Visualization](#) handbook of the User Guide.

FIBER TYPE

The **Fiber Type** is selected from the pull-down menu at the lower left under the **Fiber Options** tab. After selecting, click **Add** to include this fiber type. If the wrong fiber type has been added, discard it by clicking **Remove**.

The following combinations of fiber cross-section with fiber length and fiber shape are available:

	Short		Infinite		Curved
		Bundle		Bundle	
Circular	Short Circular	Bundle Short Circular	Infinite Circular	Bundle Infinite Circular	Curved Circular
Hollow	Short Hollow		Infinite Hollow		Curved Hollow
Rosetta	Short Rosetta		Infinite Rosetta	Bundle Infinite Rosetta	Curved Rosetta
Elliptical	Short Elliptical	Bundle Short Elliptical	Infinite Elliptical	Bundle Infinite Elliptical	Curved Elliptical
Cellulose	Short Cellulose		Infinite Cellulose		Curved Cellulose
Rectangular	Short Rectangular		Infinite Rectangular		Curved Rectangular
Angular	Short Angular		Infinite Angular		Curved Angular
Arbitrary	Short Arbitrary		Infinite Arbitrary		

Fiber cross-section

A drawing of the fiber cross-section is shown in the center column of each fiber type panel. The available fiber cross-sections and their defining parameters are:

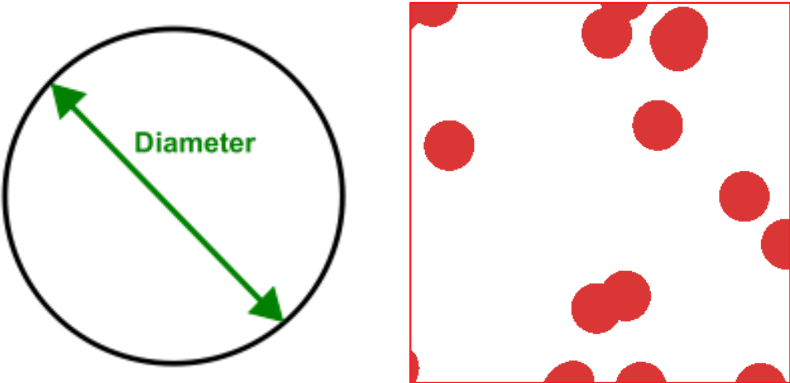
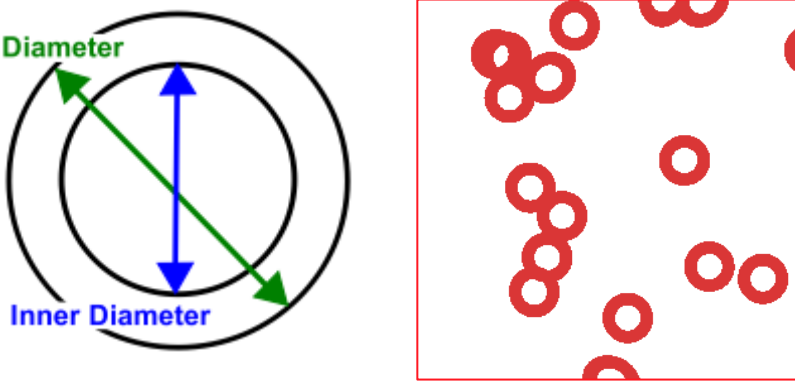
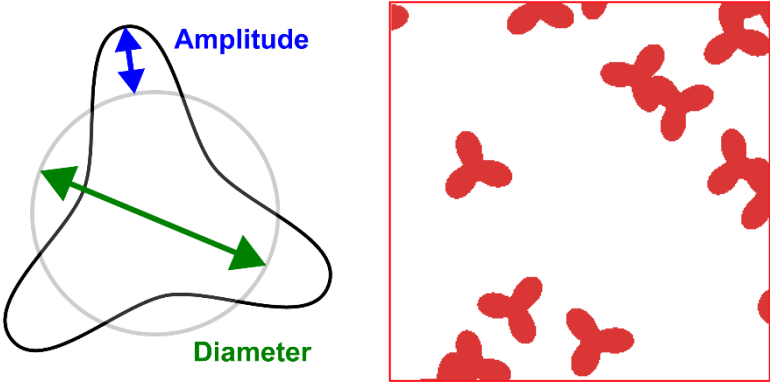
Cross-section	Defining parameters
<p style="text-align: center;">Circular</p> 	<p>Diameter / (μm)</p>
<p style="text-align: center;">Hollow</p> 	<p>Diameter / (μm) Inner Diameter Fraction</p>
<p style="text-align: center;">Rosetta</p> 	<p>Diameter / (μm) Amplitude Fraction Number of Leaves</p>

In polar coordinates, the cross-sectional shape is defined through

$$r(\phi) = \frac{\text{Diameter}}{2} \cdot (1 - \text{AmplitudeFraction} \cdot \sin(\text{NumberOfLeaves} \cdot \phi))$$

where ϕ in $[0, 2\pi]$ is the angle in the cross-sectional plane and the Diameter value is the average of the minimal and maximal diameter. Thus, the amplitude is given through:

$$\text{Amplitude} = \text{AmplitudeFraction} \cdot \text{Diameter}.$$

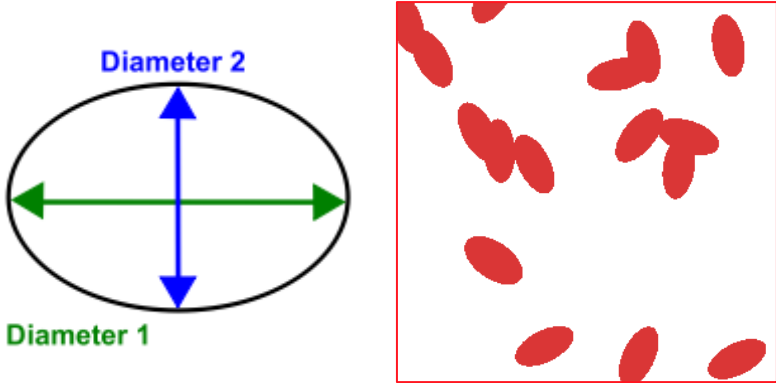
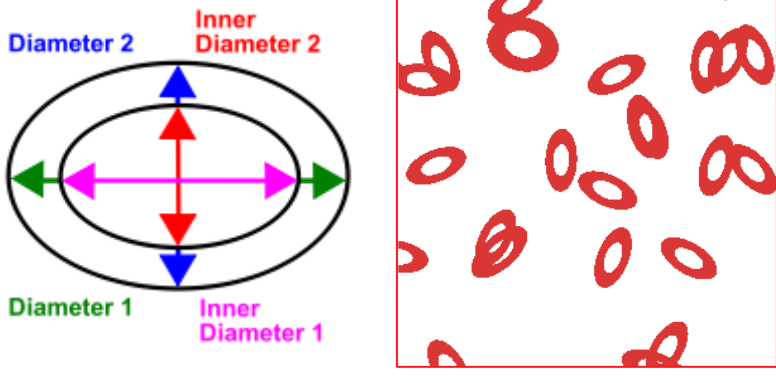
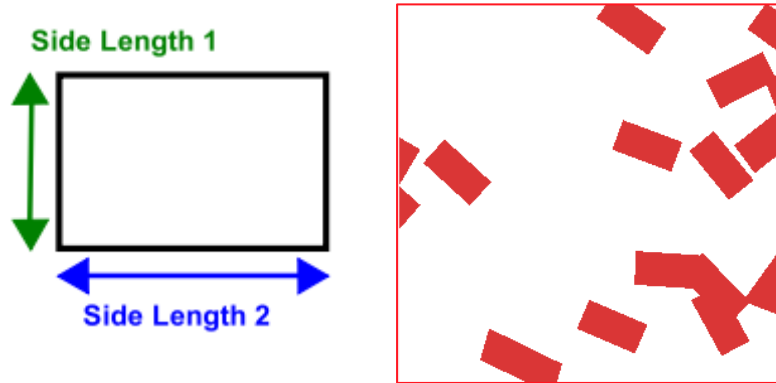
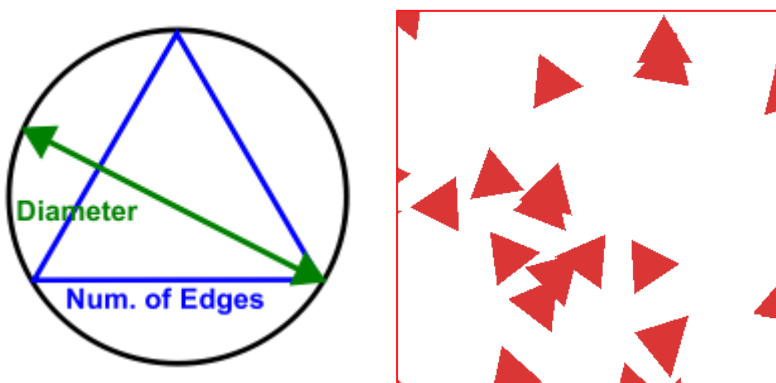
Cross-section	Defining parameters
<p style="text-align: center;">Elliptical</p> 	<p>Diameter 1 / (μm) Aspect Ratio</p>
<p style="text-align: center;">Cellulose</p> 	<p>Diameter 1 / (μm) Aspect Ratio Inner Diameter Fraction</p>
<p style="text-align: center;">Rectangular</p> 	<p>Side Length 1 / (μm) Aspect Ratio</p>
<p style="text-align: center;">Angular</p> 	<p>Diameter / (μm) Number of Edges</p>

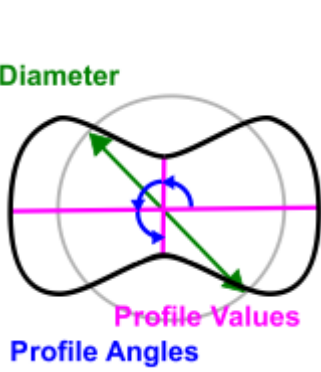
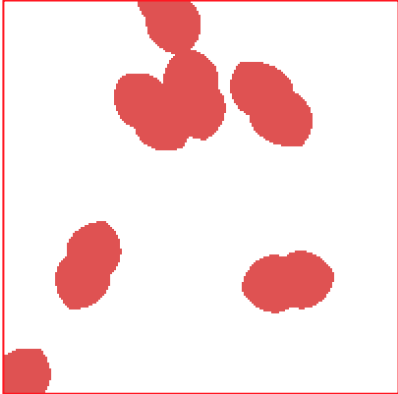
Cross-section	Defining parameters
<p style="text-align: center;">Arbitrary</p>   <p>Complex cross-sections are obtained by varying the Profile Angles and the Profile Values at these angles (Profile Value x cross-section radius, e.g. $1 \times r_1$).</p>	<p>Diameter / (μm)</p> <p>Profile Angles / ($^\circ$)</p> <p>Profile Values</p>

For example, with a diameter of 10 μm , the following arbitrary cross-sections can be obtained by applying the indicated profile angles and profile values:

Profile Angles / ($^\circ$)	<input type="text" value="90,180,270"/>
Profile Values	<input type="text" value="1,1,1,1"/>

Profile Angles / ($^\circ$)	<input type="text" value="90,180,270"/>
Profile Values	<input type="text" value="1,0.5,1,0.5"/>

Profile Angles / ($^\circ$)	<input type="text" value="45,120,280"/>
Profile Values	<input type="text" value="1,0.5,1,0.5"/>

$1 \times r \rightarrow r_1 = 5 \mu\text{m}$ at 0°
 $1 \times r \rightarrow r_2 = 5 \mu\text{m}$ at 90°
 $1 \times r \rightarrow r_3 = 5 \mu\text{m}$ at 180°
 $1 \times r \rightarrow r_4 = 5 \mu\text{m}$ at 270°

$0.5 \times r \rightarrow r_1 = 2.5 \mu\text{m}$ at 0°
 $1 \times r \rightarrow r_2 = 5 \mu\text{m}$ at 90°
 $0.5 \times r \rightarrow r_3 = 2.5 \mu\text{m}$ at 180°
 $1 \times r \rightarrow r_4 = 5 \mu\text{m}$ at 270°

$0.5 \times r \rightarrow r_1 = 2.5 \mu\text{m}$ at 0°
 $1 \times r \rightarrow r_2 = 5 \mu\text{m}$ at 45°
 $0.5 \times r \rightarrow r_3 = 2.5 \mu\text{m}$ at 120°
 $1 \times r \rightarrow r_4 = 5 \mu\text{m}$ at 280°

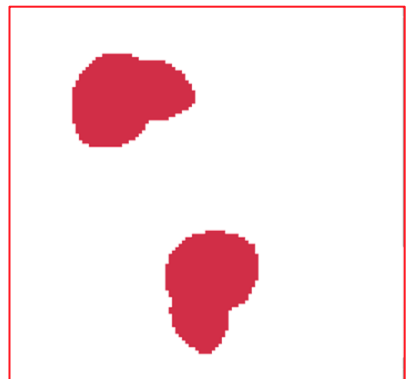
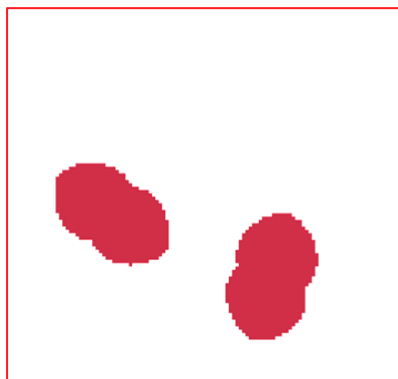
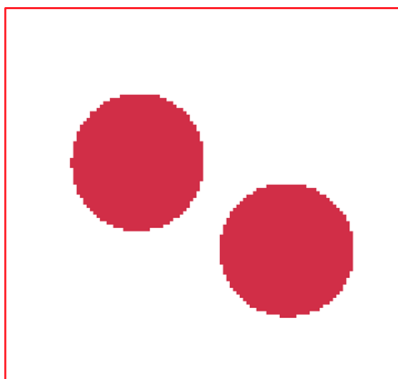

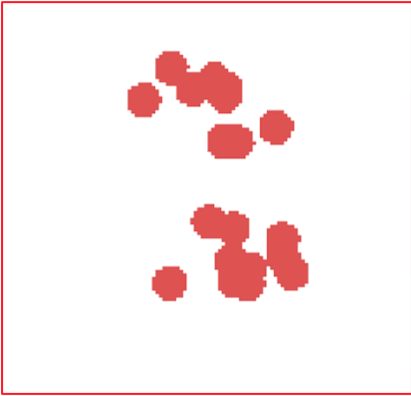
Cross section	Defining parameters
<p style="text-align: center;">Bundle</p> <div style="text-align: center;">  </div> <p>Circular, elliptical or rosetta cross-sectioned, short or infinite, fibers are clumped together forming bundles.</p> <p>The compaction of the bundles is given by the bundle diameters, the bundle profile angle and the number of fibers in it. Fibers in the bundle are defined by their diameter(s).</p>	<p>Bundle Diameter 1/(μm)</p> <p>Bundle Diameter 2/(μm)</p> <p>Number of Fibers</p> <p>Profile Angle / ($^{\circ}$)</p> <p>Diameter / (μm)</p>

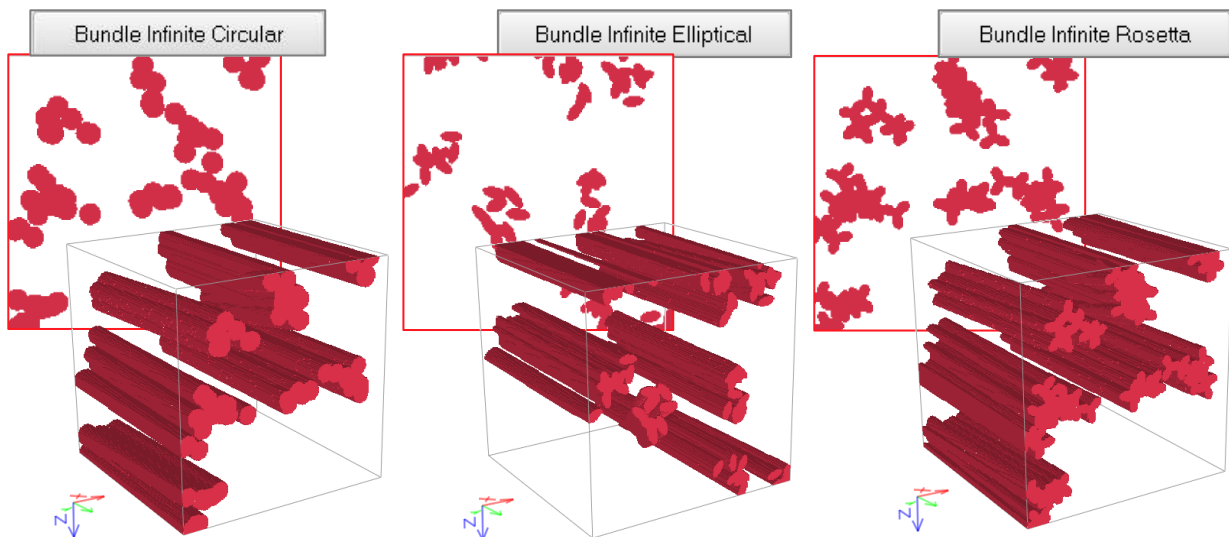

FIBER PARAMETERS

The right column of the fiber type panel contains the parameters controlling the geometrical and physical properties of each fiber type of the fibrous structure.

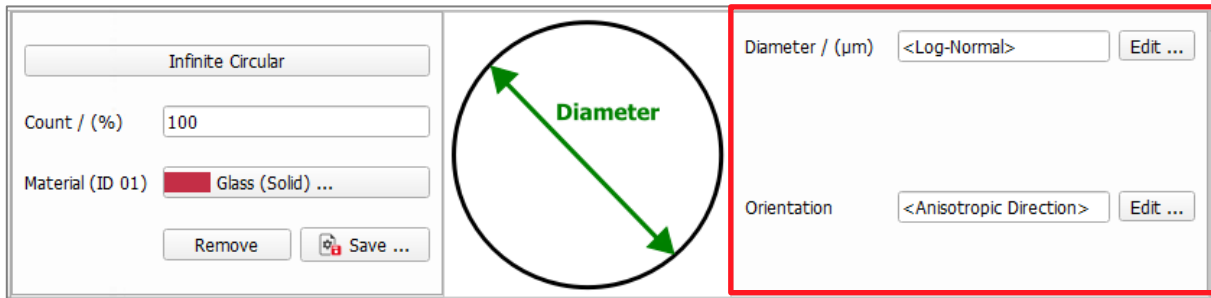

Some fiber parameters can only be set for some fiber types, such as the selections under the **Curl** tab or the **Torsion** tab for Curved Elliptical, Cellulose, Rectangular, or Angular cross-section fibers. The fiber length can only be set for finite (**Short** or **Curved**) fibers but not for **Infinite** fibers.

Constant values or Distributions of parameters

The defining parameters can be entered in the dialogs which open when clicking the corresponding **Edit...** buttons.

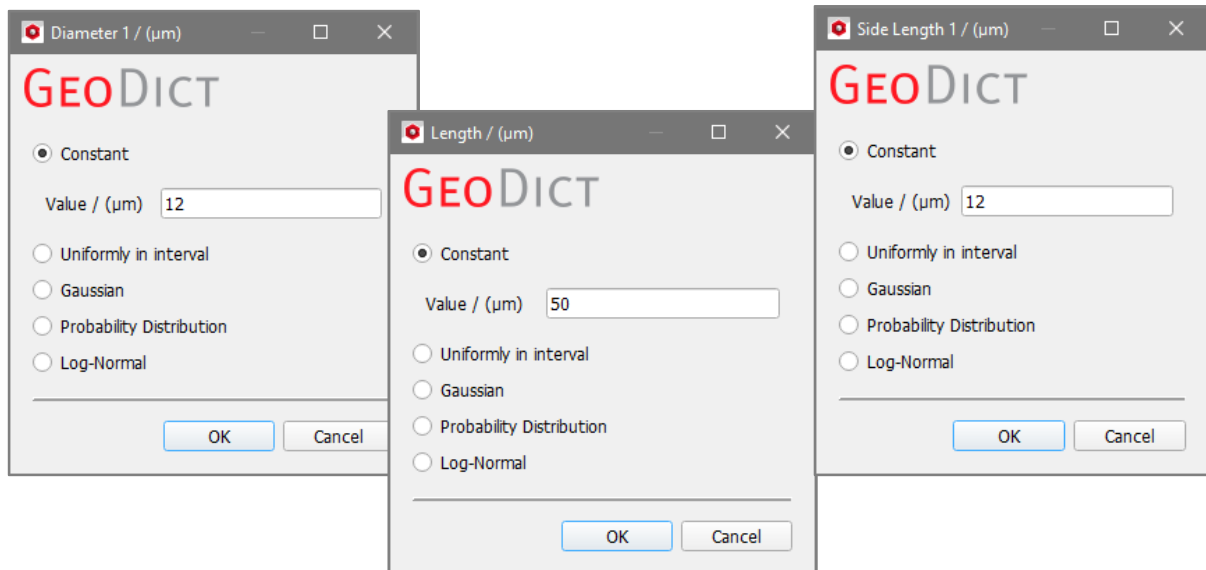

The fiber **Diameter**, the **Length**, and the **Side Length** can be set to a **Constant** value, or to follow a certain distribution (**Uniformly in interval**, **Gaussian**, **Probability Distribution**, or **Log-Normal**).

The **Center**, for short and curved fibers (not for infinite), can be set to distribute **Uniformly**, **On Current Objects** (when **Create in Current Domain** is checked under **Create Options**), **Uniformly in Box**, or to follow a **Density Distribution**.

These distributions are explained in detail below (see pages [61ff.](#), **Fiber Parameters** → **Center**).

The **Torsion Start Angle** value (for Curved Elliptical, Curved Cellulose and Curved Rectangular cross-sections) can be set to be **Constant**, to distribute **Uniformly in interval**, or to follow a **Probability Distribution**.

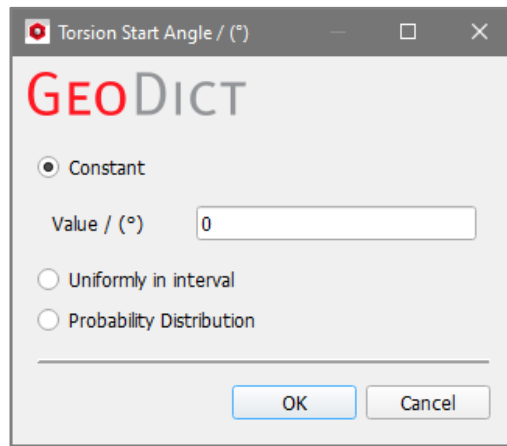
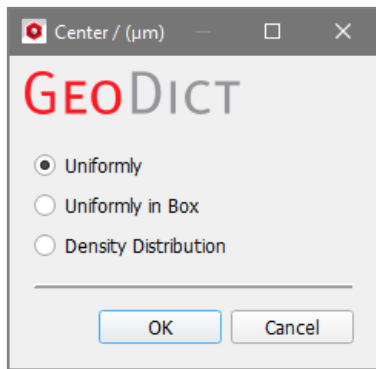

Diameter

Observe the effect that the **Diameter** options (as shown in the dialogs) have on the generated structure with infinite circular cross-section fibers. The generated structures are shown as 3D Rendering and as 2D Cross-section.

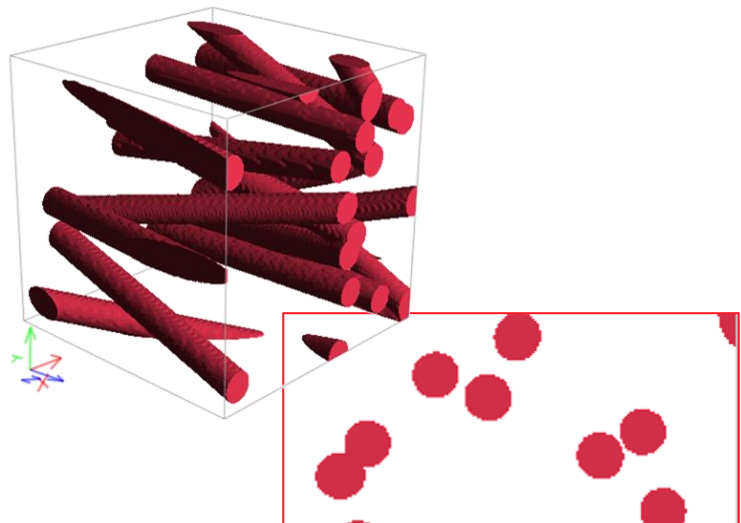
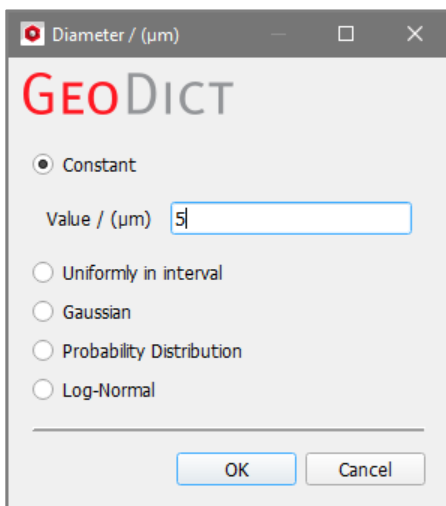

Uniformly in Interval

When selecting **Uniformly in interval**, and entering a **Minimum** value and a **Maximum** value, the diameter, length, side length or angle values are uniformly distributed within the given interval.

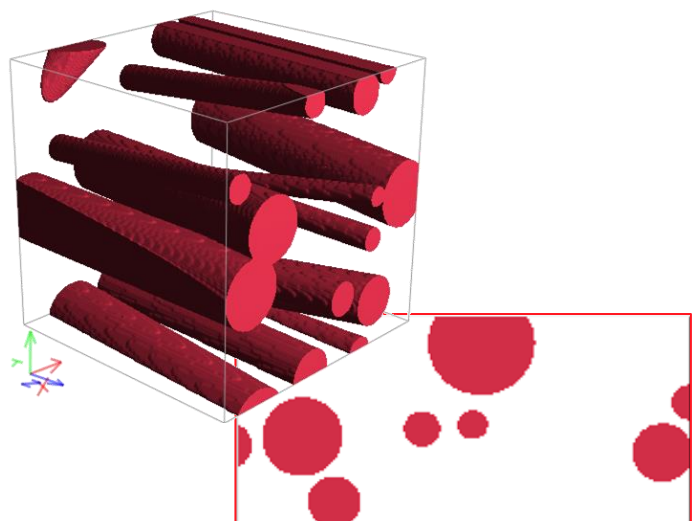
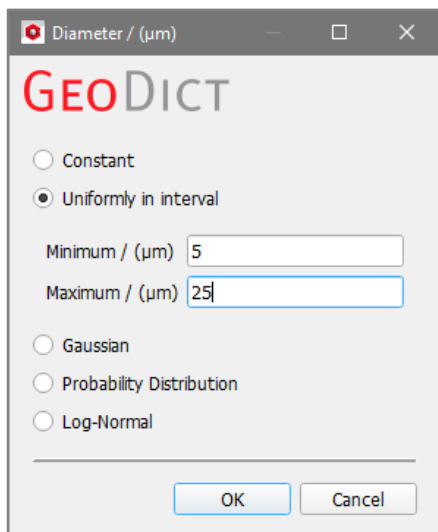

Gaussian

Taking the **Gaussian** distribution, the random diameter, length, or side length values follow a bell-shaped distribution. The values cluster around the entered **Mean Value** but may vary according to the entered **Standard Deviation**.

The value in **Distribution Bound** corresponds to the interval on both sides of the mean value limiting the random diameter or angle values that are accepted. For diameters, a **Distribution Bound** value of 10 μm means that the diameter values may vary only -10 μm to +10 μm from the given **Mean Value**.

The parameters must be set so that no negative values are possible. For example, a diameter mean value of 20 μm and a distribution bound of 25 μm would lead to an error message appearing, as the diameter could reach a value less than zero.

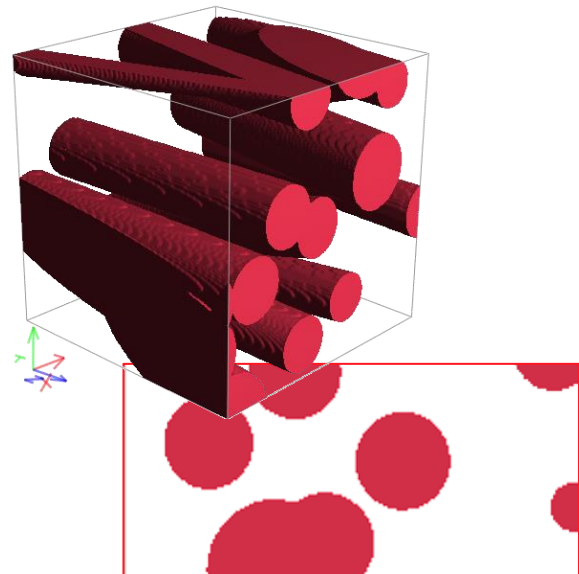
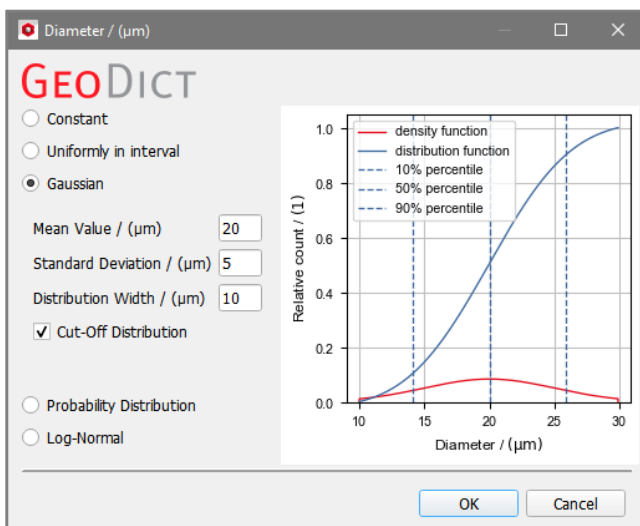
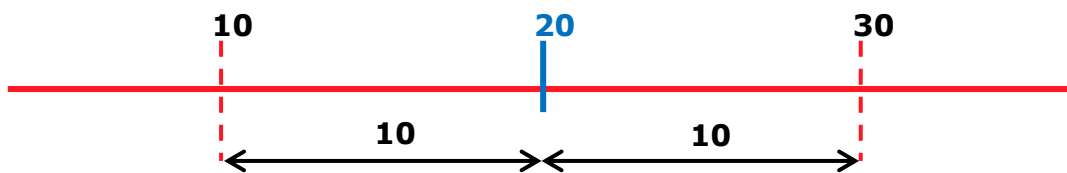

For all distribution options (Gaussian, Probability Distribution and Log-Normal) the distribution is visualized on the right of the dialog in a 2D plot.

The **red** line visualizes the **Diameter Percentage Distribution** defined by Mean Value, Standard Deviation and Distribution Width. It displays how much fibers of which diameter will be generated in percent.

The **blue** curve visualizes the cumulative diameter distribution.

The three **dashed blue** lines show the diameter values for the 10% percentile, the 50% percentile and the 90% percentile of the distribution. On average, 10% of the fibers have a diameter smaller than the 10% percentile value, and 90% of the generated fibers have a diameter higher than that value. For further explanations, see the [Wikipedia](#) article.

Right-clicking in the plot opens a dialog to **save** the plot or to **Edit the Axis Settings**. Checking or unchecking the checkboxes next to the graph names decides which curves are displayed.

More information about these options can be found in the [Result Viewer](#) handbook of the User Guide.

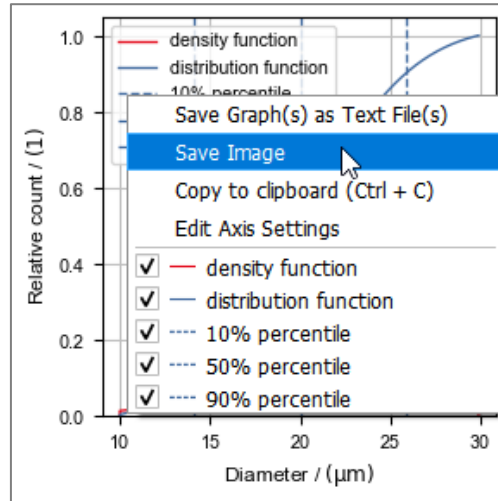

If **Cut-Off Distribution** is checked, the distribution is truncated at the bounds. This means that all values outside the bounds are dropped and not considered for generation. If this option is not checked, then all values that are outside of the bounds are set to be on the distribution bound. Not checking this option leads to an accumulation of values on the bounds.

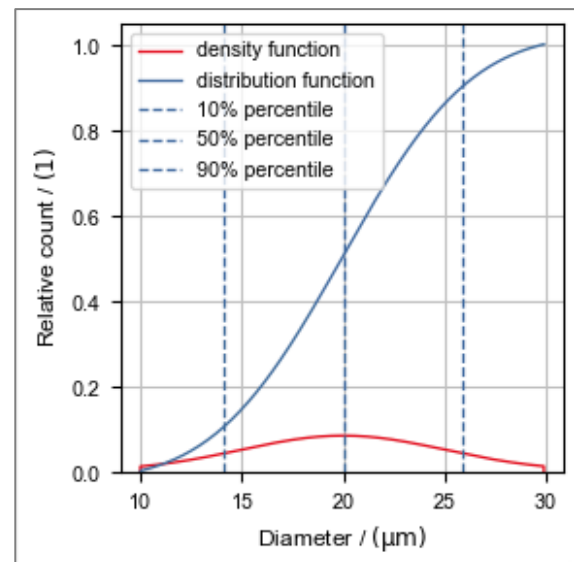
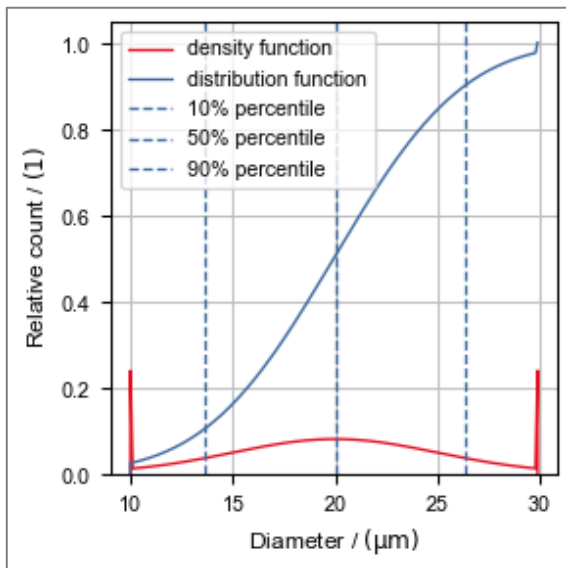

In the example below not checking **Cut-Off Distribution** leads to many fibers with diameters of 40 or 60 μm. In contrast, checking **Cut-Off Distribution** leads to more fibers with diameter between 40 and 60 μm.

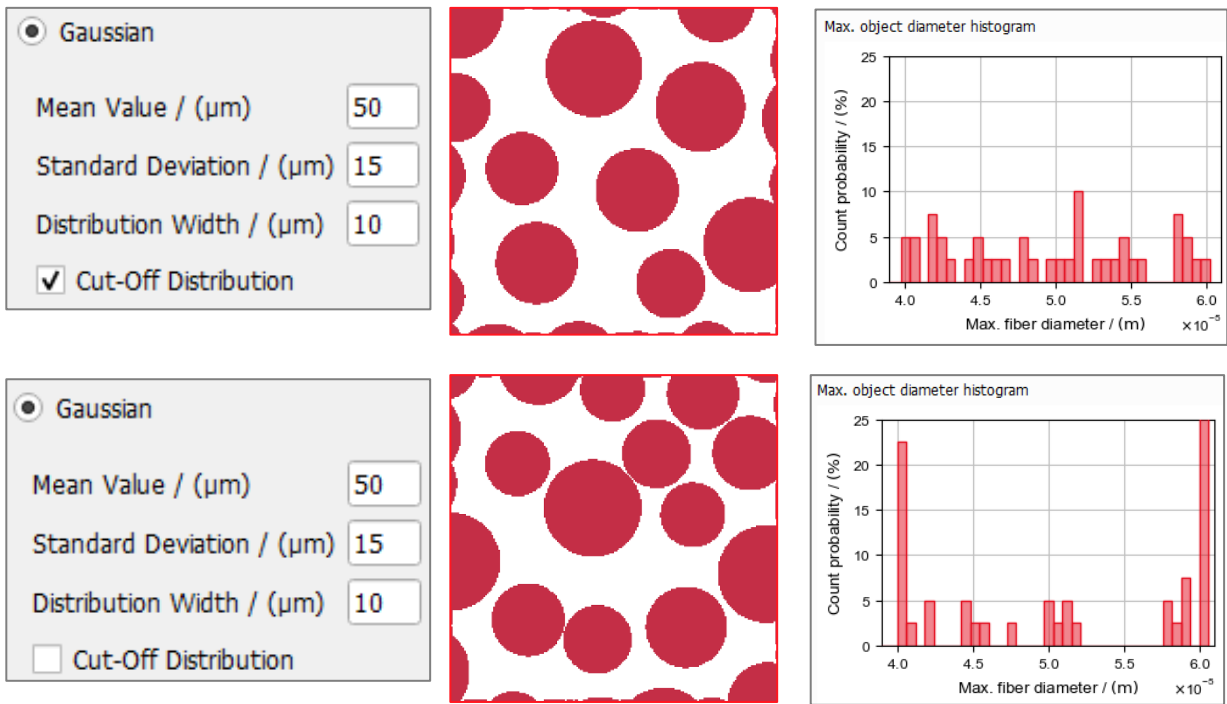

Further details on Gaussian distributions can be found e.g. on the [Wikipedia](#) page on Normal (or Gaussian) distributions.

Probability Distribution

The **Probability Distribution** table enables entering user-defined probability distributions. The **Number of Rows** can be increased or decreased to enter as many diameter, length, or angle **Values** and their **Count Probability**, between 0 and 1.

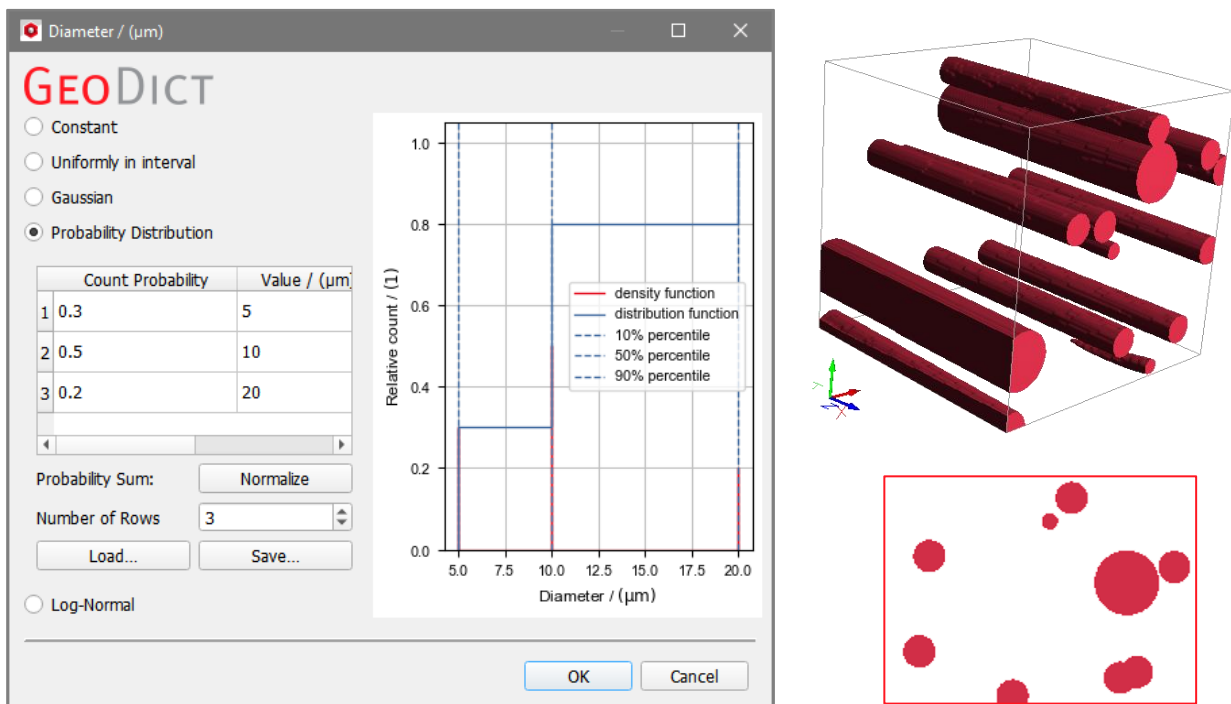

It is useful to observe the value of **Probability Sum**, i.e. the sum of the count probabilities. When the **Probability Sum** is not equal to 1, click the **Normalize** button to automatically round up the **Count Probability** values.

The buttons **Load** and **Save** allow loading a previous probability distribution and saving the current one for later use.

Log-Normal

The **Log-Normal** distribution describes the situation in which the logarithm of the diameter values follows a normal distribution.

The diameter values will group around the entered **Mean Value** and scatter according to the entered **Standard Deviation**. The values in **Lower Bound** and **Upper Bound** restrict the possible values that the random diameters can take to the given interval.

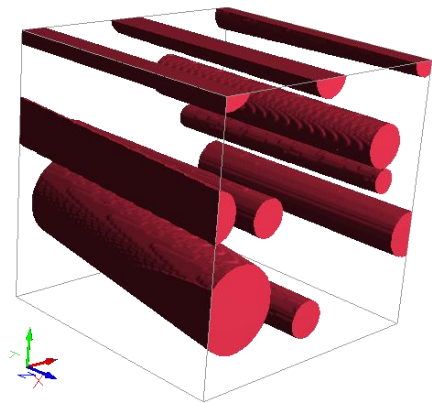
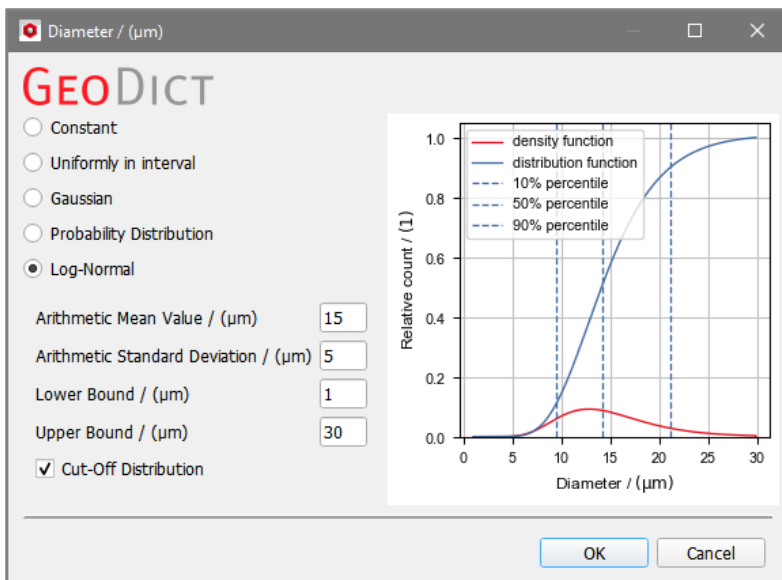

Diameter, Inner Diameter Fraction, Aspect Ratio, and Amplitude Fraction

A circular fiber has only one diameter value. The **Diameter** value can be edited by clicking the **Edit...** button to open the **Diameter** dialog. The circular fiber diameter can be set to have a **Constant** value, or to follow a diameter distribution (**Uniformly in interval**, **Gaussian**, **Probability Distribution**, or **Logarithmic-Normal (Log-Normal)**) as indicated above.

For non-circular fibers, the diameter and other parameters control their shape. For a hollow fiber, the **Inner Diameter Fraction** defines which fraction of the entered (outer) diameter value is to be taken as inner diameter value.

Diameter / (µm)	20
Inner Diameter Fraction	0.25

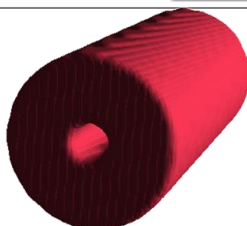

Diameter / (µm)	20
Inner Diameter Fraction	0.5

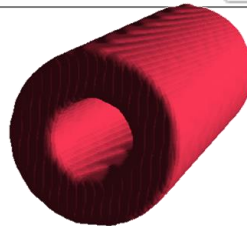

Diameter / (µm)	20
Inner Diameter Fraction	0.75

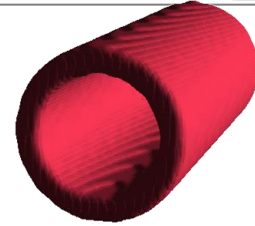

For fibers with **Rosetta cross-section**, the **Amplitude Fraction** determines the length of the rosetta leaves, whereas the **Number of Leaves** defines how many leaves the rosetta has.

Diameter / (μm)	20
Amplitude Fraction	0.25
Number of Leaves	4

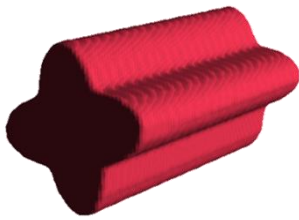

Diameter / (μm)	20
Amplitude Fraction	0.5
Number of Leaves	4

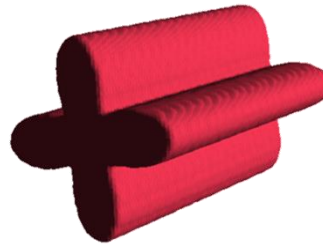

Diameter / (μm)	20
Amplitude Fraction	0.75
Number of Leaves	4

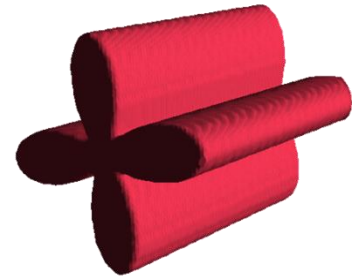

For **Elliptical** fibers, defined by two diameters, the **Aspect Ratio** is the relationship between the longer diameter (Diameter 1) and the shorter diameter (Diameter 2).

Diameter 1 / (μm)	20
Aspect Ratio	0.25

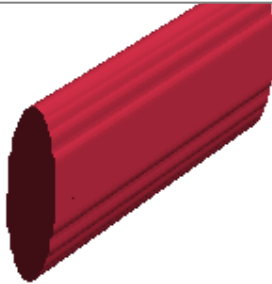

Diameter 1 / (μm)	20
Aspect Ratio	0.5

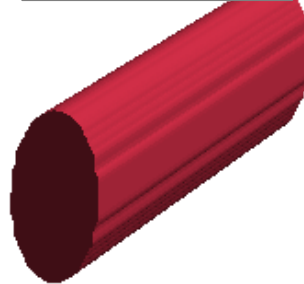

Diameter 1 / (μm)	20
Aspect Ratio	0.75

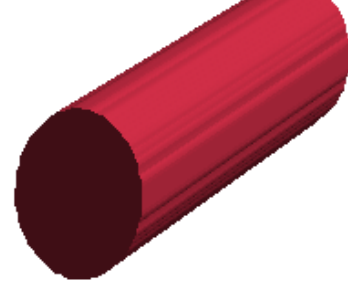

Length and Side Length

Fibers can have **Finite** or **Infinite** length. There exist two types of finite fibers: Finite short fibers (**Short**) are straight and finite curved fibers can be curved (**Curved**).

Short Cellulose

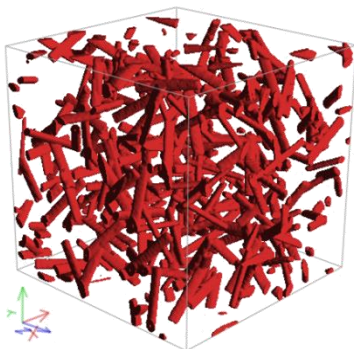

Curved Cellulose

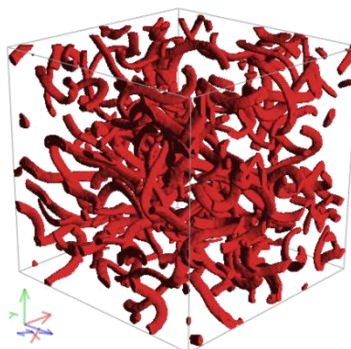

Infinite Cellulose

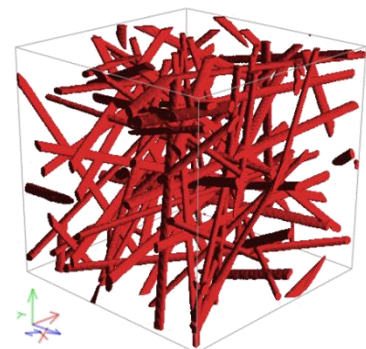

The length of **Short** and **Curved** fibers is editable by clicking on the **Edit...** button and choosing the desired settings in the **Length (μm)** dialog. The fiber **Length**, and **Side Length**, can be set to take a **Constant** value, or to follow a distribution (**Uniformly in interval**, **Gaussian**, **Probability Distribution**, or **Logarithmic-Normal**).

Diameter 1 / (μm)
 Aspect Ratio
 Inner Diameter Fraction
Length / (μm)
 Orientation
 Center / (μm)
 Rounded Endings
 Couple Diameter 1 / Dtex and Length

Length / (μm)
GEODICT
 Constant
 Value / (μm)
 Uniformly in interval
 Gaussian
 Probability Distribution
 Log-Normal

For fibers with rectangular cross-section, the **Side Length 1** and the **Aspect Ratio** can be entered. The relationship between these parameters is like that between Diameter 1 and Aspect Ratio for Elliptical cross-sectioned fiber explained above.

$$\text{Side Length 2} = \text{Side Length 1} \times \text{Aspect Ratio}$$

Side Length 1

Side Length 2

Length

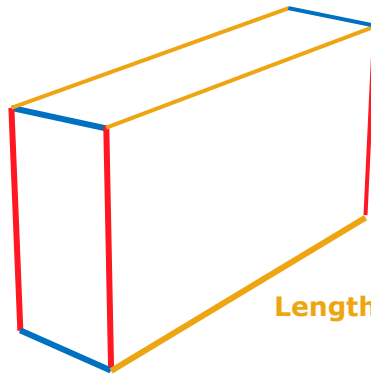

Side Length 1 / (μm)
 Aspect Ratio



Side Length 1 / (μm)
 Aspect Ratio

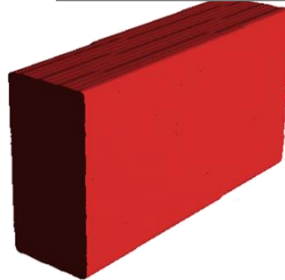

Side Length 1 / (μm)
 Aspect Ratio

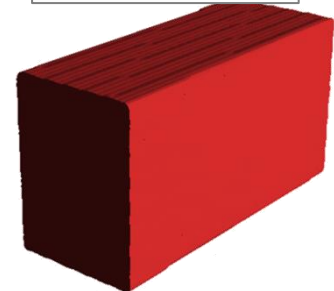

Infinite fibers are straight. Thus, to generate structures with (nearly) infinite length fibers that are curved, choose a curved fiber type and set the fiber length much larger than the sample size.

Rounded Endings

Short fibers with any cross-section (Circular, Hollow, Rosetta, Cellulose, Elliptic, Rectangular and Angular) can be created with or without rounded ends by checking or leaving un-checked the **Rounded Endings** box.

Observe the variation in the shape of the short rectangular fibers after checking the **Rounded Endings** box.



Couple Diameters / Side Length or Dtex and Length

The diameter/side length or Dtex and the length of **Short** and **Curved** fibers with any cross-section (Circular, Hollow, Rosetta, Cellulose, Elliptic, Rectangular and Angular) can be coupled by checking **Couple Diameter/Dtex and Length** or **Couple Side Length 1/Dtex and Length**. Clicking the **Edit...** button, the coupling of these parameters is set through values entered in the probability-coupled distribution table.

The following structure, entirely made of short circular fibers, is generated with the coupled values for diameter and length entered in the coupled distribution table shown here. Observe the three distinct sizes of short circular fibers which have all the same length of 40 μm but different diameters: 50% with diameter 5 μm , 20% with diameter 20 μm , and 30% with diameter 10 μm .

Count	Probability	Diameter / (μm)	Length / (μm)
1	0.5	5	40
2	0.2	20	40
3	0.3	10	40

Dialog Box Parameters:

- Diameter / (μm), Length / (μm) [Edit...]
- Orientation: <Anisotropic Direction> [Edit...]
- Center / (μm): <Uniformly Distributed> [Edit...]
- Rounded Endings
- Couple Diameter / Dtex and Length

Orientation

The isotropic or anisotropic **Orientation** of a fiber type in a generated structure can be set by clicking the **Edit...** button. The orientation can be separately set for each fiber type so that differently oriented fibers may coexist within the same structure.

In the **Orientation** dialog, the user defines if fibers should be **Isotropic**, have a certain **Anisotropic Direction**, **Anisotropic Orientation**, **Given Directions**, are oriented **In XY-Plane** or have a maximum **Angle Around Direction**. See how to set the values for Anisotropy 1 and 2 (pages [56ff.](#)).

For all fiber types, either with rotationally symmetric cross-section (**Circular** and **Hollow**) or with rotationally asymmetric cross-sections (**Rosetta**, **Elliptical**, **Cellulose**, **Rectangular**, and **Angular**), it is possible to control not only the fiber direction but the position of the cross-section with respect to the XY-plane as well (see below, pages [48ff.](#)).

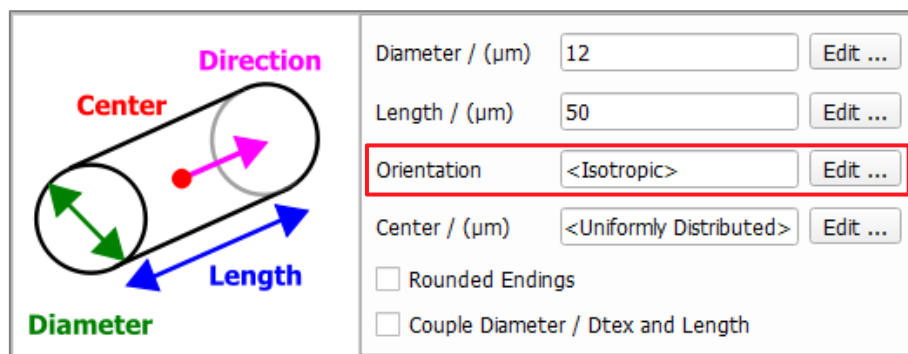

Isotropic

In an **Isotropic** orientation, all directions have the same probability.

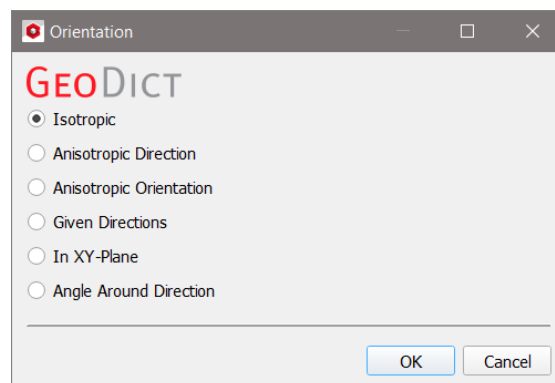

Anisotropic Direction

When checking **Anisotropic Direction** or **Anisotropic Orientation** and selecting **Anisotropy Parameter** from the **Direction Mode** pull-down menu, the Anisotropy Parameters (Anisotropy 1 and Anisotropy 2, see page [56](#)), as well as the **Phi**, **Theta** and **Psi Euler Angles** for the three-dimensional rotation of anisotropic fibers can be defined.

The Euler rotation angles are applied to the fibers during the generation following the order Phi → Theta → Psi.

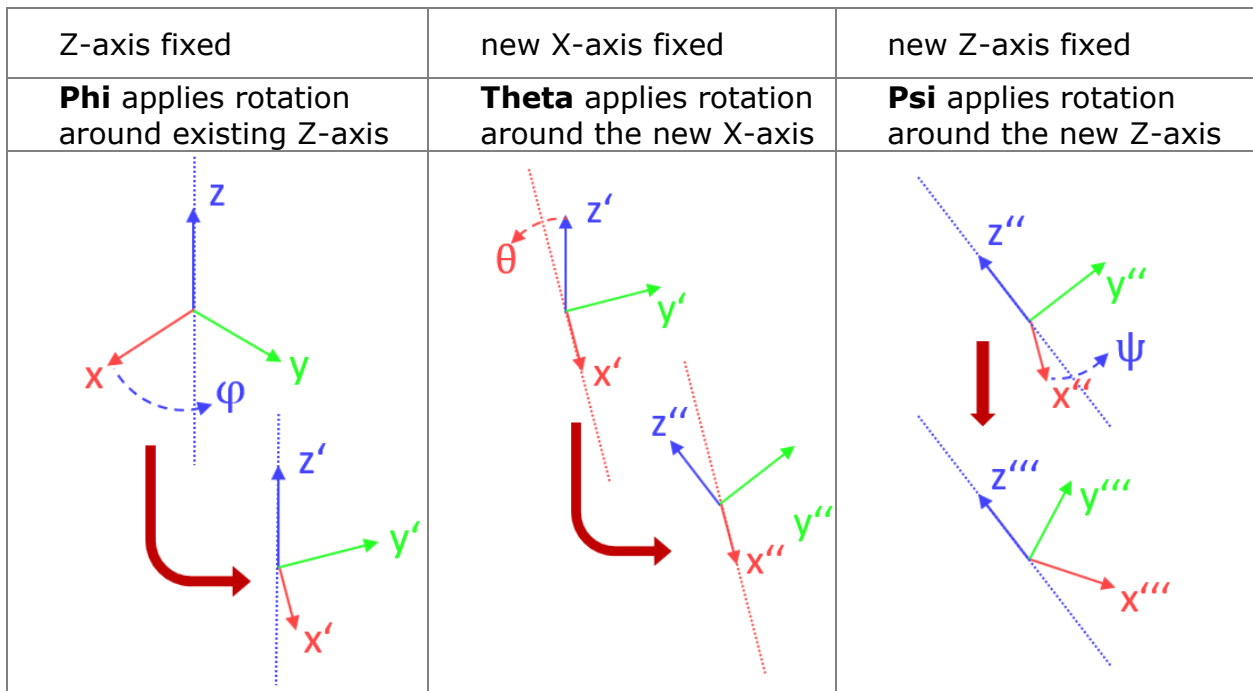

Alternatively, when selecting **Orientation Tensor** from the **Direction Mode** pull-down menu, the values for the direction tensor of the anisotropic fibers can be entered. The **Orientation Tensor** provides an equivalent alternative to the combination of the **Anisotropy Parameters** and the **Euler Angles**.

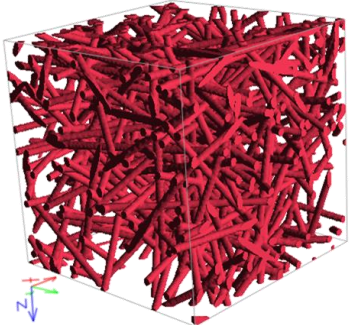

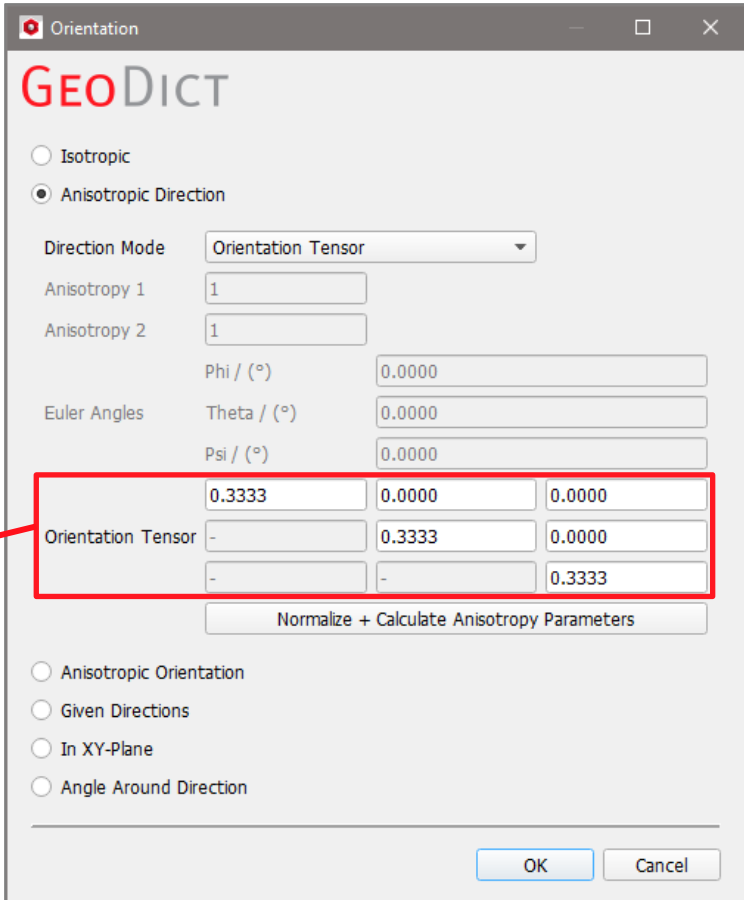

In detail, let $\mathbf{d}_k = \begin{pmatrix} x_k \\ y_k \\ z_k \end{pmatrix}$ be the unit vector describing the direction of the k^{th} fiber and n the number of the fibers. Then the orientation tensor \mathbf{T} is the sum over the dyadic products of the \mathbf{d}_k from all n fibers, divided by n :

$$\mathbf{T} = \frac{1}{n} \left(\sum_{k=1}^n \mathbf{d}_k \mathbf{d}_k^T \right) = \frac{1}{n} \sum_{k=1}^n \begin{pmatrix} x_k x_k & x_k y_k & x_k z_k \\ y_k x_k & y_k y_k & y_k z_k \\ z_k x_k & z_k y_k & z_k z_k \end{pmatrix} = \begin{pmatrix} t_{11} & t_{12} & t_{13} \\ t_{21} & t_{22} & t_{23} \\ t_{31} & t_{32} & t_{33} \end{pmatrix}.$$

The diagonal elements define the orientation strength for the corresponding directions and sum up to 1. Thus, if for example $t_{11} = 1$ (and $t_{22} = t_{33} = 0$), all fibers are oriented in the X-direction. For $t_{11} = 0$ all fibers are oriented normal to the X-direction and same values for all diagonal elements ($t_{11} = t_{22} = t_{33} = \frac{1}{3}$) result in a uniform distribution for the fiber orientation.

Observe the effect of changing the default values of the isotropic Orientation Tensor to obtain anisotropic fibrous structures oriented in the X-, Y-, or Z-direction.

X-direction

	0.7	0.0000
Orientation Tensor	-	0.15
	-	0.15

Y-direction

0.15	0.7	0.0000
Orientation Tensor	-	0
	-	0.15

Z-direction

0.15	0.0000	0.7
Orientation Tensor	-	0
	-	0.15

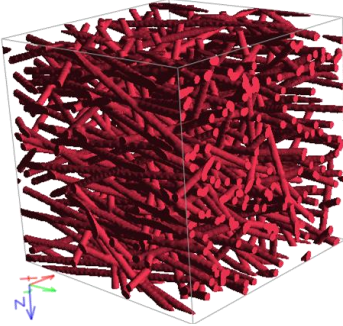

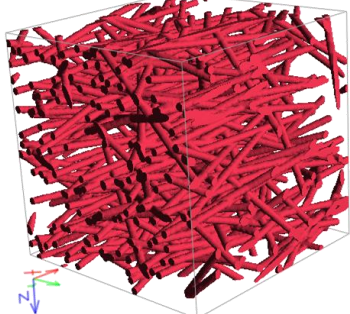

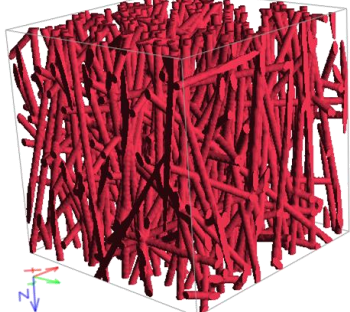

The extra-diagonal values define the statistical variation of the orientations given by the diagonal values. For example, if t_{11} has a high value near 1, and t_{12} has a relatively high value near 0.1, less fibers are oriented straight in X-direction than it is the case for a lower value for t_{12} .

Realized direction tensor:		
0.8932	0.0130	-0.0001
-	0.1066	-0.0003
-	-	0.0002

Target direction tensor:		
0.8995	0.0000	0.0000
-	0.1000	0.0000
-	-	0.0005

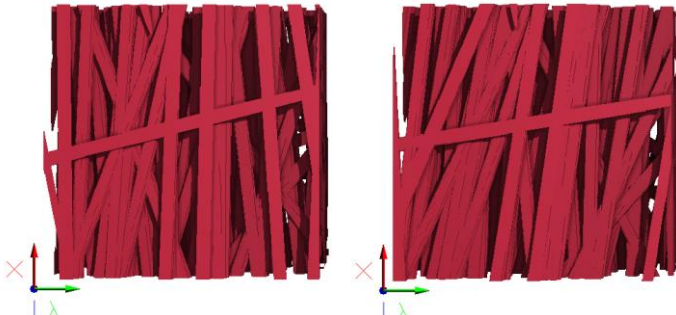

Realized direction tensor:		
0.9006	0.1080	0.0003
-	0.0992	-0.0007
-	-	0.0002

Target direction tensor:		
0.8995	0.1000	0.0000
-	0.1000	0.0000
-	-	0.0005

Clicking the **Normalize + Calculate Anisotropy Parameters** button, the **Orientation Tensor** is normalized, and the **Anisotropy values** and the **Euler Angles** are calculated and entered in the boxes above.

Anisotropic Orientation

To control not only the fiber direction of the fibers but the position of the cross-section with respect to the XY-plane as well, check **Anisotropic Orientation** and select either **Anisotropy Parameter** or **Orientation Tensor** from the **Orientation Mode** pull-down menu.

The angle between the fiber cross section axis and XY-plane can be entered in the **Profile Angle to XY-Plane** box. Note, that it has no visible effect on rotationally symmetric fibers.

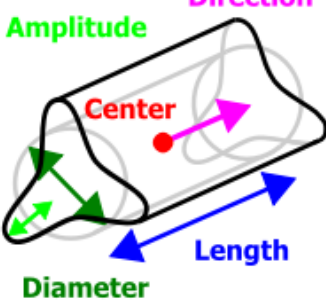

Diameter / (μm)	12	Edit ...
Amplitude Fraction	0.5	
Number of Leaves	3	
Length / (μm)	50	Edit ...
Orientation	<Isotropic>	Edit ...
Center / (μm)	<Uniformly Distributed>	Edit ...
<input type="checkbox"/>	Rounded Endings	
<input type="checkbox"/>	Couple Diameter / Dtex and Length	

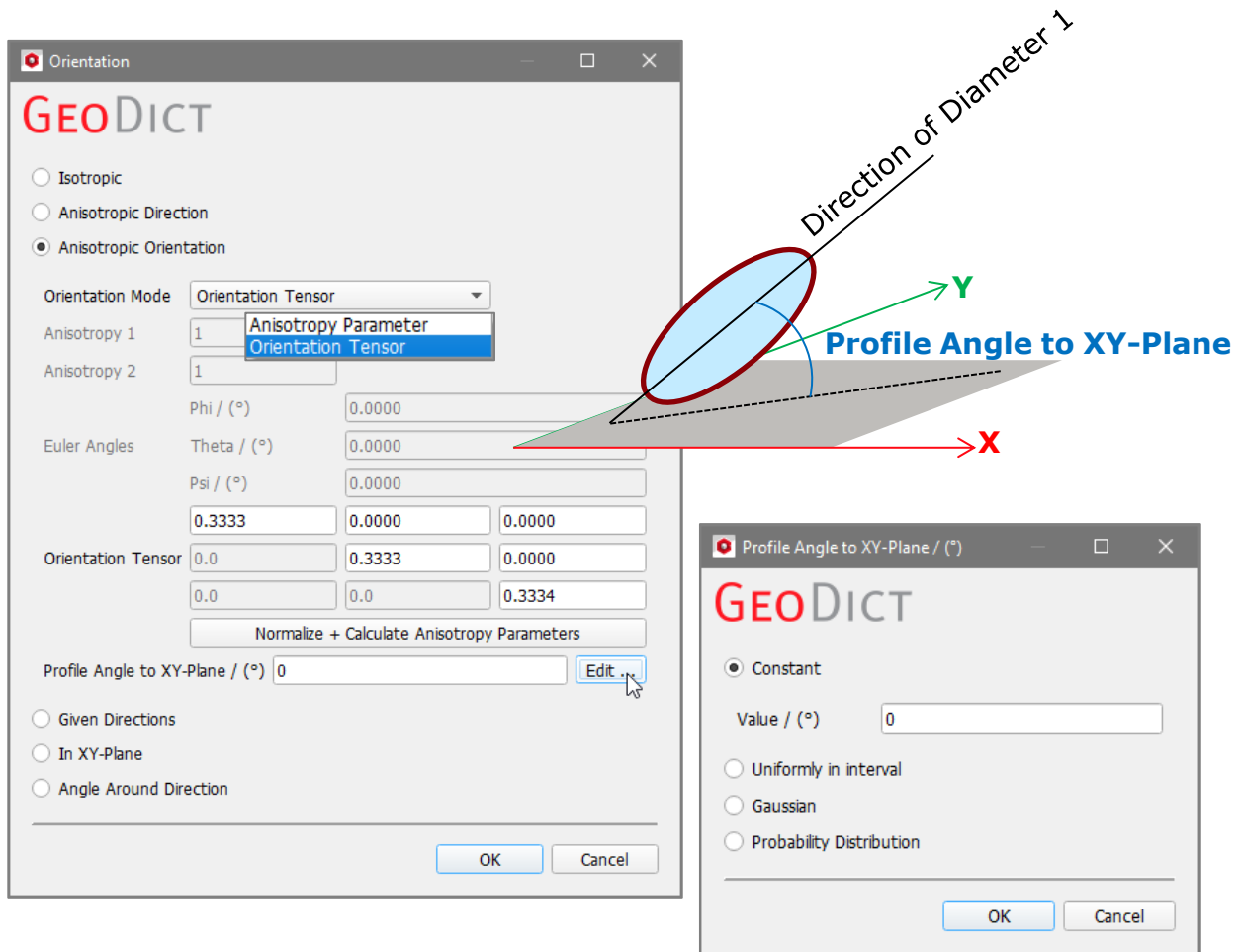

For this, in the **Orientation** dialog, check **Anisotropic Orientation**, and in the opening panel enter the **Profile Angle to XY-Plane** value or click the **Edit...** button to access the **Profile Angle to XY-Plane [°]** dialog. The fiber **Profile Angle to XY-Plane**, can be set to be a **Constant** value, or to follow a distribution (**Uniformly in interval**, **Gaussian**, or **Probability Distribution**).

The screenshot displays the GEO-DICT software interface with several dialog boxes open, illustrating the configuration of anisotropic orientation and profile angle distributions.

Orientation Dialog Box:

- Radio buttons: Isotropic, Anisotropic Direction, Anisotropic Orientation
- Orientation Mode: Anisotropy Parameter
- Anisotropy 1: 1
- Anisotropy 2: 1000
- Phi / (°): 0
- Euler Angles: Theta / (°): 0, Psi / (°): 0
- Orientation Tensor: 0.0009, 0.0000, 0.0000; 0.0, 0.9982, 0.0000; 0.0, 0.0, 0.0009
- Buttons: Normalize + Calculate Anisotropy Parameters, OK, Cancel

Profile Angle to XY-Plane / (°) Dialog Box (Top Left):

- Radio buttons: Constant, Uniformly in interval, Gaussian, Probability Distribution
- Value / (°): 0
- Buttons: OK, Cancel

Profile Angle to XY-Plane / (°) Dialog Box (Middle Left):

- Radio buttons: Constant, Uniformly in interval, Gaussian, Probability Distribution
- Minimum / (°): 0
- Maximum / (°): 0
- Buttons: OK, Cancel

Profile Angle to XY-Plane / (°) Dialog Box (Bottom Left):

- Radio buttons: Constant, Uniformly in interval, Gaussian, Probability Distribution
- Mean Value / (°): 45
- Standard Deviation / (°): 5
- Distribution Width / (°): 10
- Cut-Off Distribution
- Buttons: OK, Cancel

Profile Angle to XY-Plane / (°) Dialog Box (Bottom Right):

- Radio buttons: Constant, Uniformly in interval, Gaussian, Probability Distribution
- Table:

Count	Probability	Value / (°)
1	0.2	25
2	0.5	34
3	0.3	60
- Buttons: Normalize, Save...
- Graph: Relative count / (1) vs Profile Angle to XY-Plane / (°). Legend: density function, distribution function, 10% percentile, 50% percentile, 90% percentile.
- Buttons: OK, Cancel

Red dashed arrows indicate the flow of data and settings between the windows, showing how parameters from the Orientation dialog are used in the Profile Angle dialog boxes, and how the Probability Distribution dialog box is used to generate the graph.

Observe the effect of varying the **Profile Angle To XY-Plane** in a structure made of Short Elliptical fibers strongly oriented in the Y-axis (Anisotropy 1 = 1, Anisotropy 2 = 1000). Other parameters are unchanged.

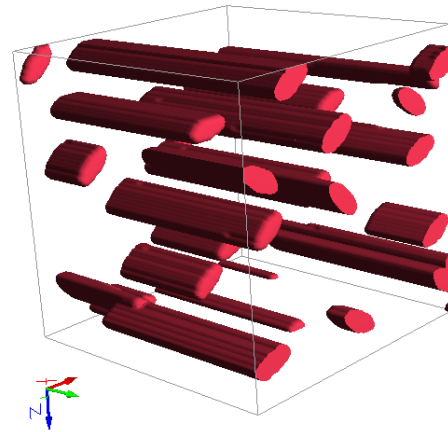
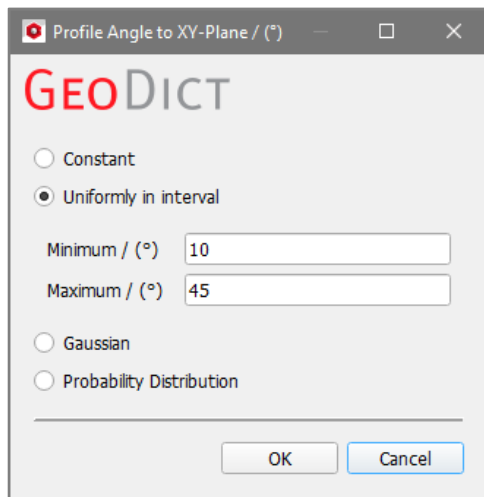
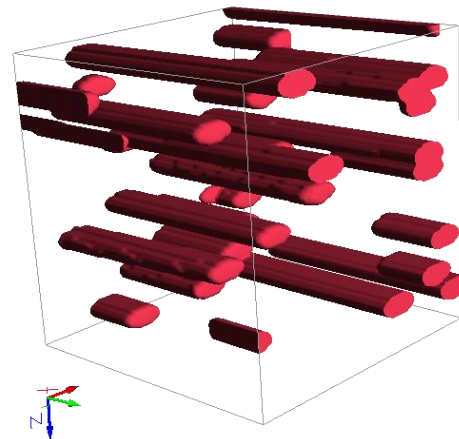
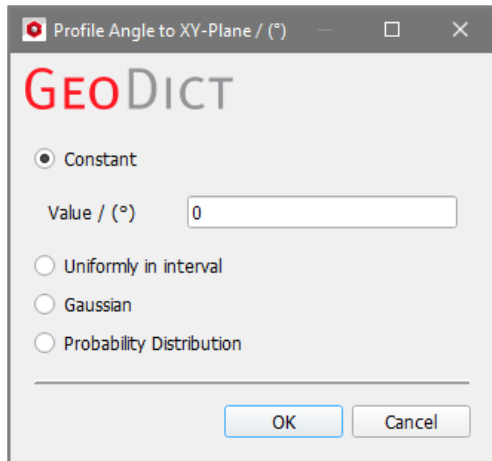

50% of the elliptical fibers are at an angle of 45° with the XY-plane, 30% lie on the plane (0° angle), and 20% are at a 25° angle.

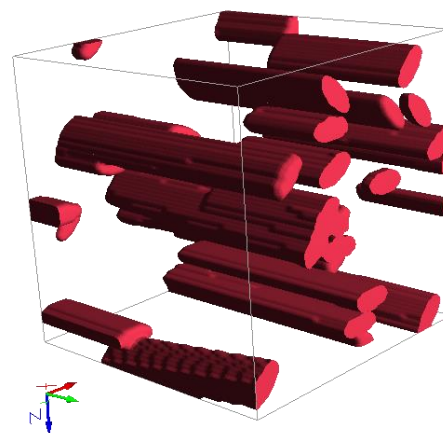
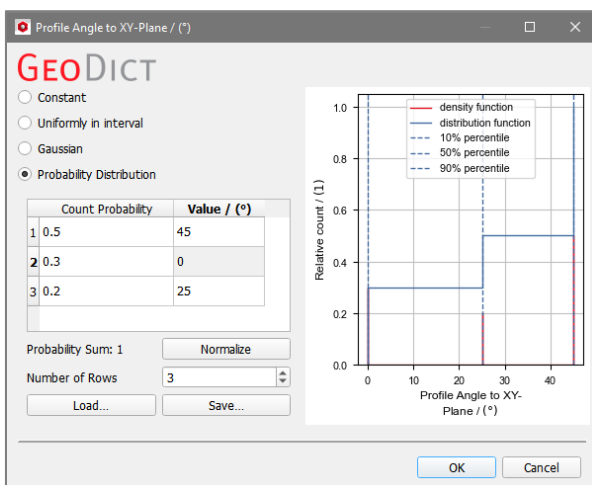

Given Directions

By checking **Given Directions**, count probabilities can be entered for different direction vectors for the fibers in the generated structure.

In the left column enter the **Count Probability**. A value of 1 means all fibers will have the given direction on the right. For example, a **Count Probability** of 1 for the direction vector (0, 0, 1) means that all fibers follow the Z-direction, and (1, 0, 0) means that all fibers follow the X-direction.

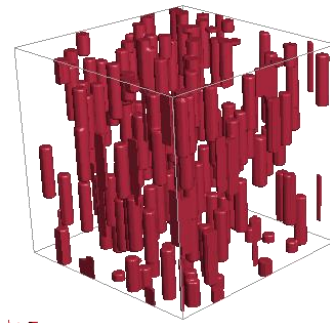
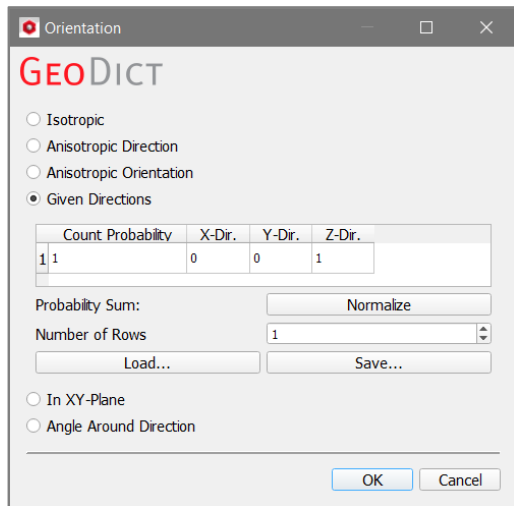

Count Probability	X-Dir.	Y-Dir.	Z-Dir.
1	1	0	0

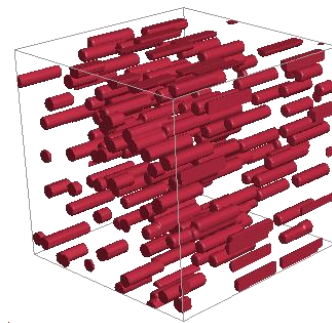

If more rows are given, every given direction will be applied to the generated fibers with the corresponding count probability. In the following example observe how 80% of the fibers are oriented in X-direction while the other 20% are oriented along the Z-axis.

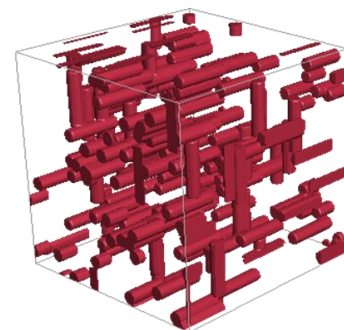
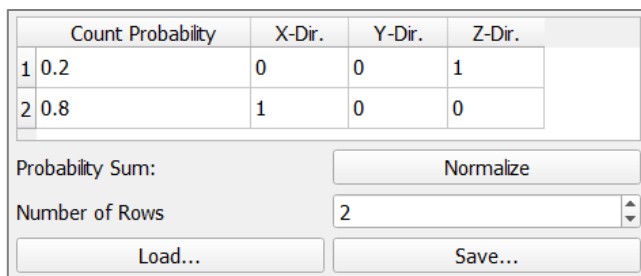

Clicking the **Normalize** button ensures the **Count Probability** values sum up to one.

The **Given Directions** distribution settings can be saved and loaded by clicking **Save** and **Load**, respectively.

Every direction in the 3-dimensional space is possible, as seen in these examples:

Count	Probability	X-Dir.	Y-Dir.	Z-Dir.
1	1	1	0	1

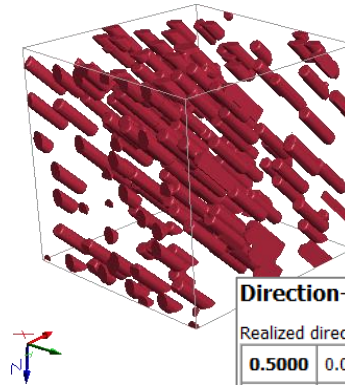

Direction-tensor object type 1:

Realized direction tensor:

0.5000	0.0000	0.5000
-	0.0000	0.0000
-	-	0.5000

Count	Probability	X-Dir.	Y-Dir.	Z-Dir.
1	1	1	0.5	0

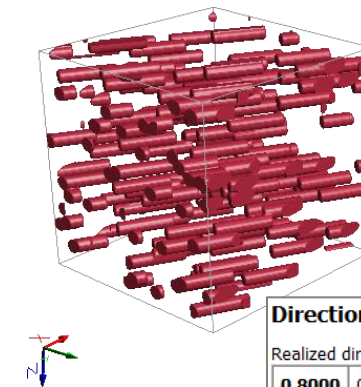

Direction-tensor object type 1:

Realized direction tensor:

0.8000	0.4000	0.0000
-	0.2000	0.0000
-	-	0.0000

In XY-Plane

By checking **In XY-Plane**, the angle of the fibers main axis in the XY-Plane can be set. The fibers lay on the XY-Plane and their main axis orientation in relation to the X-direction is controlled by the entered value.

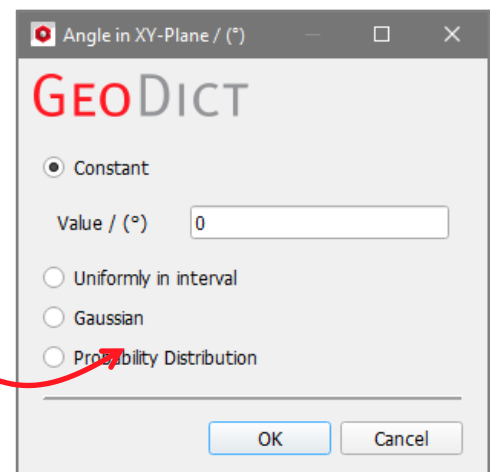
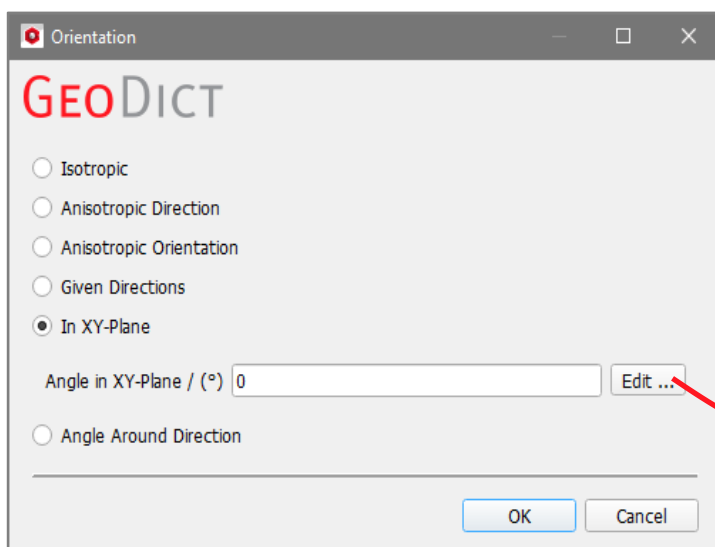

For example, enter 0°, 30°, 45°, or 90°, to obtain the following fiber orientations in the XY-Plane:

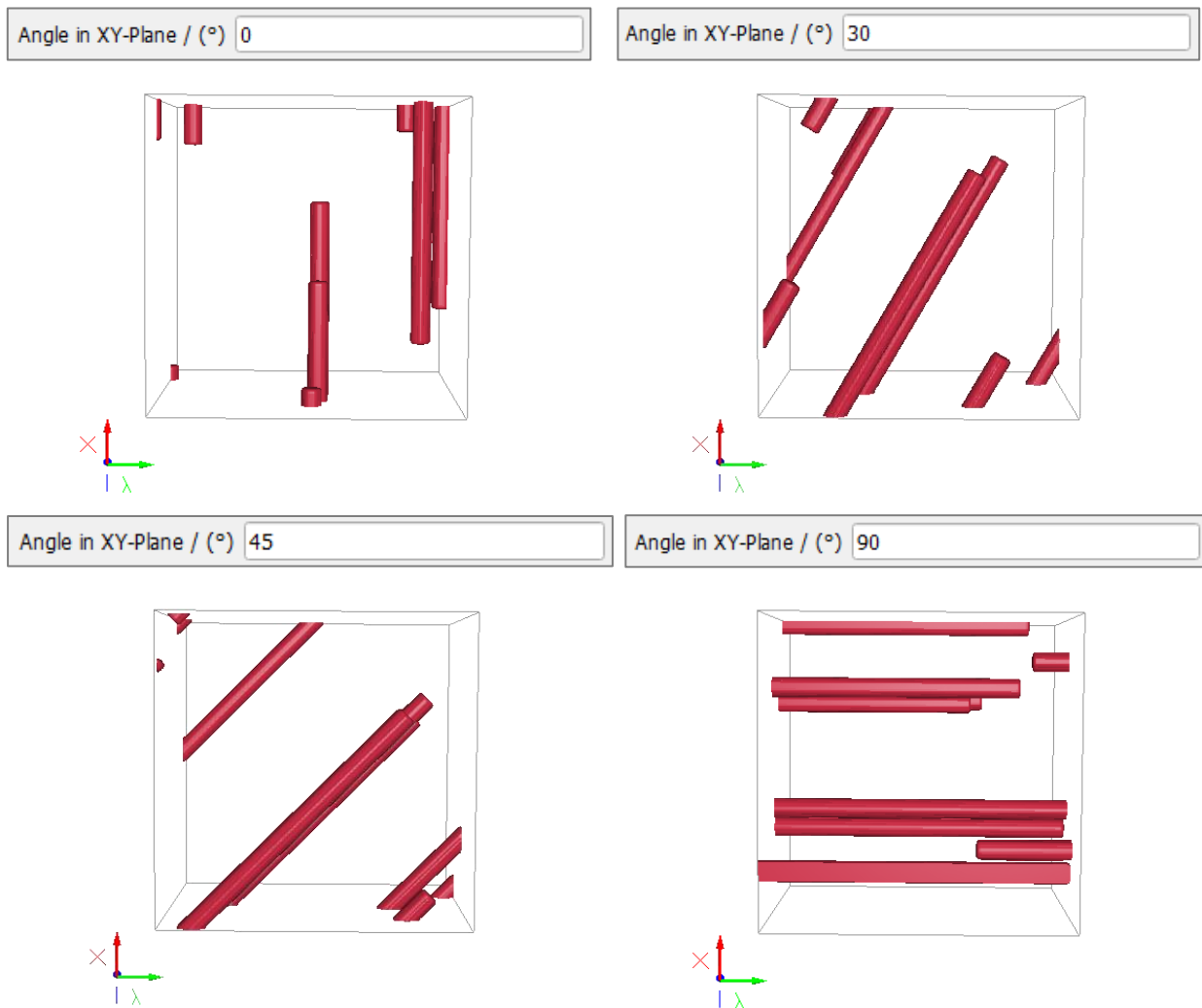

Angle Around Direction

If **Angle Around Direction** is checked define the **Main Direction Vector** of the fibers generated in the structure. The orientation of the fibers can vary if an **Angle Around Direction** is given.

The **Angle Around Direction** defines the maximum angle the fiber orientation varies from the Main Direction.

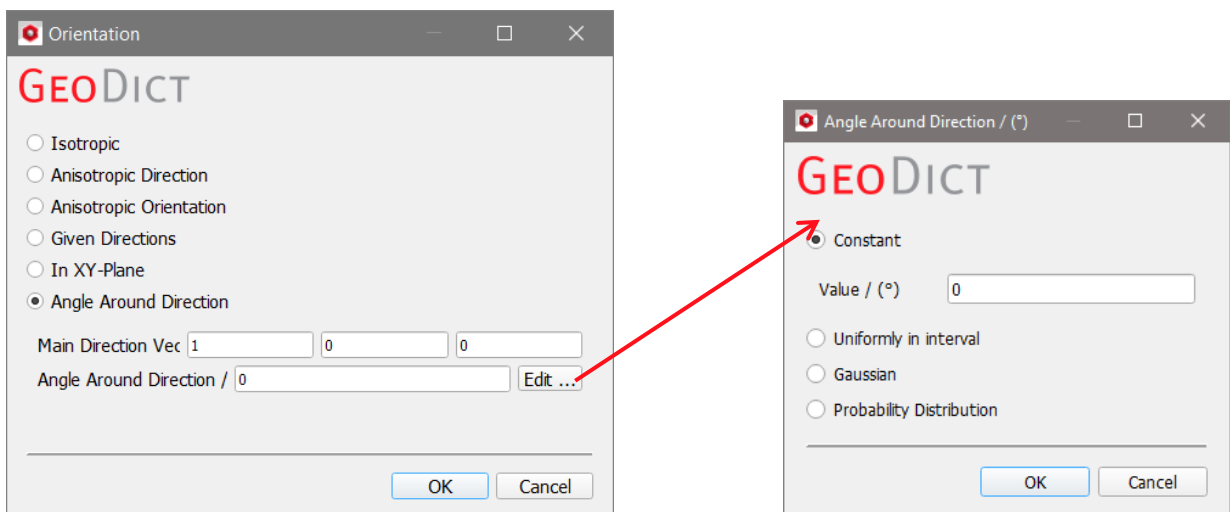

Observe how the orientation varies in the following example with angles around direction of 0°, 5° and 10° and a **Main Direction Vector** of (1, 0, 0).

Angle Around Direction

Main Direction Vector

Angle Around Direction / (°)

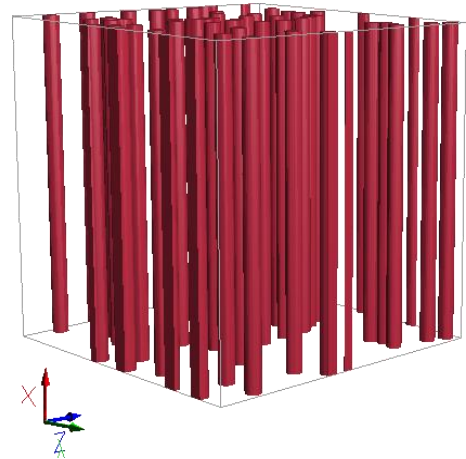

Angle Around Direction

Main Direction Vector

Angle Around Direction / (°)



Angle Around Direction

Main Direction Vector

Angle Around Direction / (°)

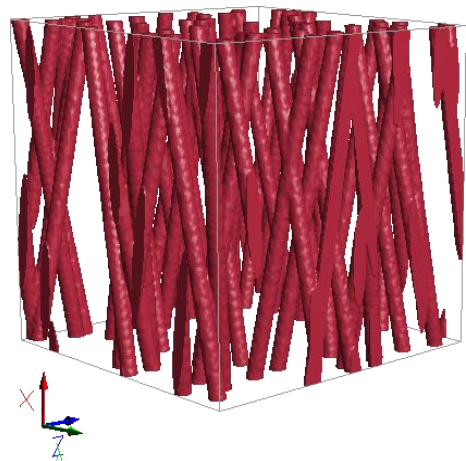

Selecting Anisotropy Parameters

The **Anisotropy Parameters** Anisotropy 1 (a_1) and Anisotropy 2 (a_2) allow to define the orientation of the fibers. Anisotropy parameters and the Orientation Tensor are equivalent representations for the orientation, and **GeoDict** can compute one from the other automatically. The fibers are created with random orientations, following a distribution defined by the given parameters.

The Algorithm

For each fiber, a random direction is computed

$$d = \begin{pmatrix} x \\ y \\ z \end{pmatrix}$$

which follows an isotropic distribution. Afterwards the **Anisotropy Parameters** are used to influence these orientations. Before normalization, the resulting vector for the fiber orientation is:

$$d_a = \begin{pmatrix} x_a \\ y_a \\ z_a \end{pmatrix} = \begin{pmatrix} a_1 \cdot x \\ a_1 \cdot a_2 \cdot y \\ z \end{pmatrix}$$

With normalization follows:

$$d_{normalized} = \frac{1}{|d_a|} d_a = \frac{1}{\sqrt{(a_1 x)^2 + (a_1 a_2 y)^2 + z^2}} \begin{pmatrix} a_1 x \\ a_1 a_2 y \\ z \end{pmatrix}$$

Before normalization, **Anisotropy 1** controls the first two coordinates, while **Anisotropy 2** only affects the second coordinate and none of them changes the third. After normalization, the Anisotropy parameters both have impact on all three coordinates, where the influence on the fiber direction differs. Whereas high values for **Anisotropy 1** lead to fibers parallel to the XY-plane, high values for **Anisotropy 2** result in fibers oriented in Y-direction. Fibers oriented in Z-direction are obtained by low values for Anisotropy 1 and low values for **Anisotropy 2** result in fibers parallel to the XZ-plane.

In the following, five main cases for the Anisotropy parameters are described:

Anisotropy 1 = Anisotropy 2 = 1 (Isotropic material)

The fiber orientation is isotropic. All directions have the same probability, as the direction obtained from the random algorithm is not changed:

$$d_a = \begin{pmatrix} a_1 x \\ a_1 a_2 y \\ z \end{pmatrix} = \begin{pmatrix} 1 \cdot x \\ 1 \cdot 1 \cdot y \\ z \end{pmatrix} = \begin{pmatrix} x \\ y \\ z \end{pmatrix} = d$$

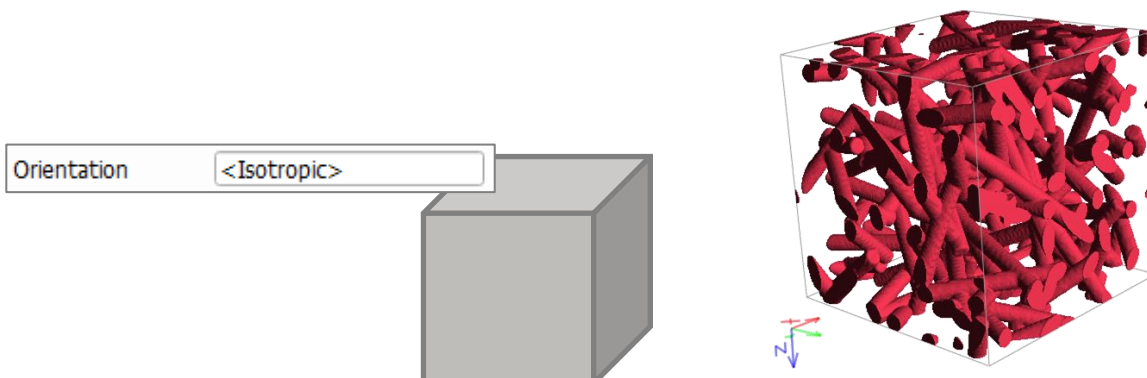

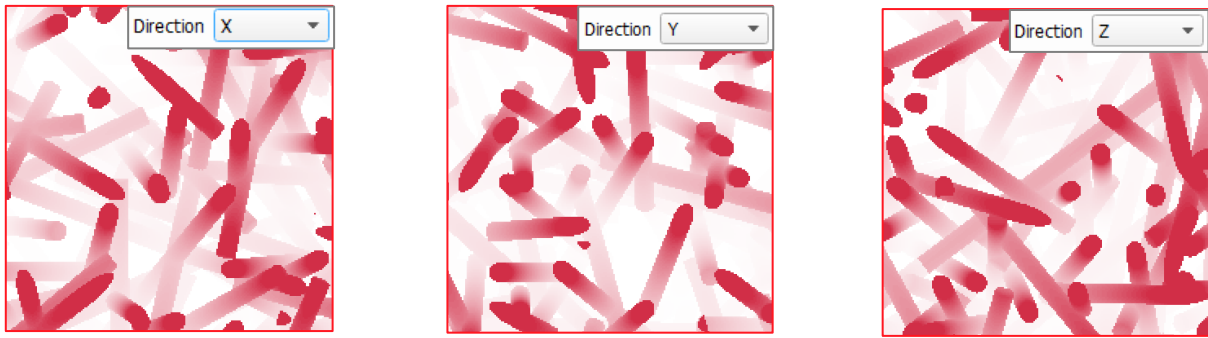

Anisotropy 1 < 1 and Anisotropy 2 = 1

Values smaller than 1 for **Anisotropy 1** lead to orientations in Z-direction, so that the fibers run parallel to the YZ-plane and the XZ-plane when viewed from the X- or Y-direction. The smaller the value of **Anisotropy 1**, the more anisotropic the fibers behave.

For example, with the values 0.01 for **Anisotropy 1** and 1 for **Anisotropy 2** it follows:

$$d_a = \begin{pmatrix} a_1 x \\ a_1 a_2 y \\ z \end{pmatrix} = \begin{pmatrix} 0.01 \cdot x \\ 0.01 \cdot y \\ z \end{pmatrix}$$

Thus, after normalization the direction vectors of the fibers approximate the unit vector:

$$d_{normalized} = \frac{1}{\sqrt{0.0001 \cdot x^2 + 0.0001 \cdot y^2 + z^2}} \begin{pmatrix} 0.01 \cdot x \\ 0.01 \cdot y \\ z \end{pmatrix} \cong \begin{pmatrix} 0 \\ 0 \\ 1 \end{pmatrix}$$

That results in fibers oriented in Z-direction.

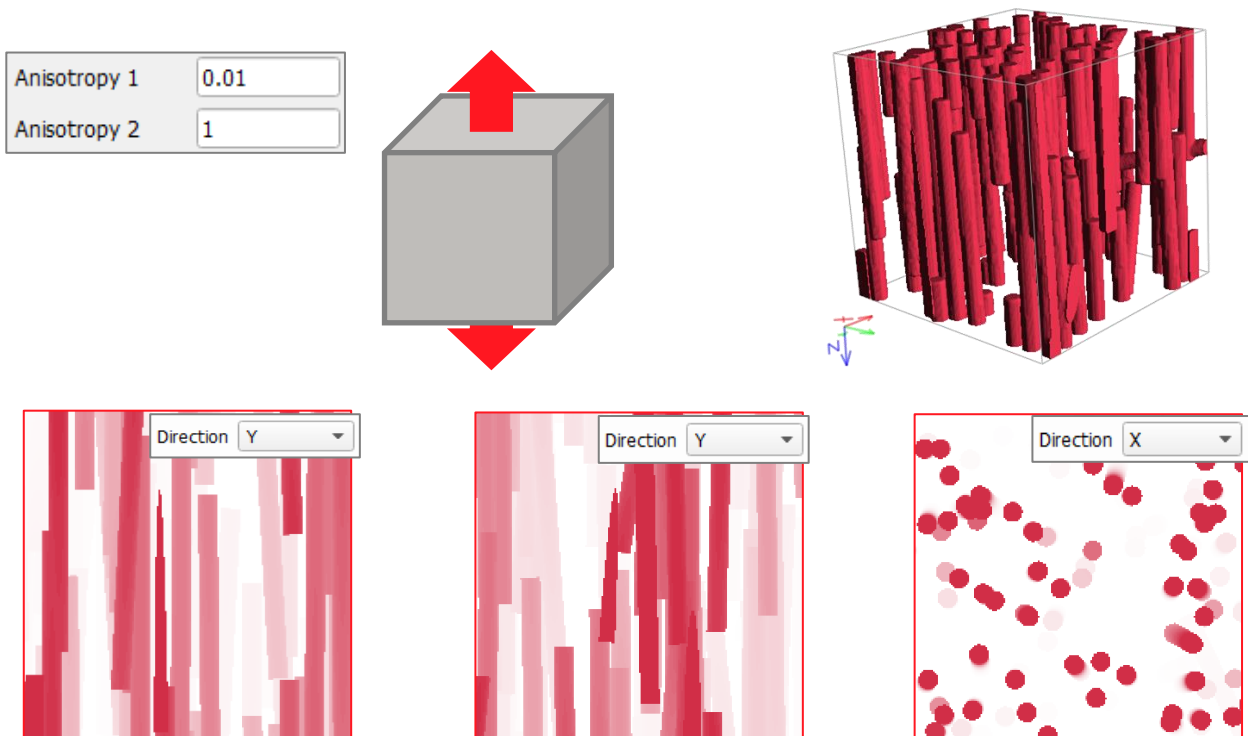

Anisotropy 1 > 1 and Anisotropy 2 = 1

The fibers are isotropic in the XY-plane (Z-slice). The higher the value of **Anisotropy 1**, the stronger is the anisotropy.

For example, with the values 100 for **Anisotropy 1** and 1 for **Anisotropy 2** it follows:

$$d_a = \begin{pmatrix} a_1 x \\ a_1 a_2 y \\ z \end{pmatrix} = \begin{pmatrix} 100 \cdot x \\ 100 \cdot y \\ z \end{pmatrix}$$

Thus, after normalization the direction vectors of the fibers approximate the vector:

$$d_{normalized} = \frac{1}{\sqrt{10000 \cdot x^2 + 10000 \cdot y^2 + z^2}} \begin{pmatrix} 100 \cdot x \\ 100 \cdot y \\ z \end{pmatrix} \cong \begin{pmatrix} x \\ y \\ 0 \end{pmatrix}$$

That results in fibers oriented in the XY-plane.

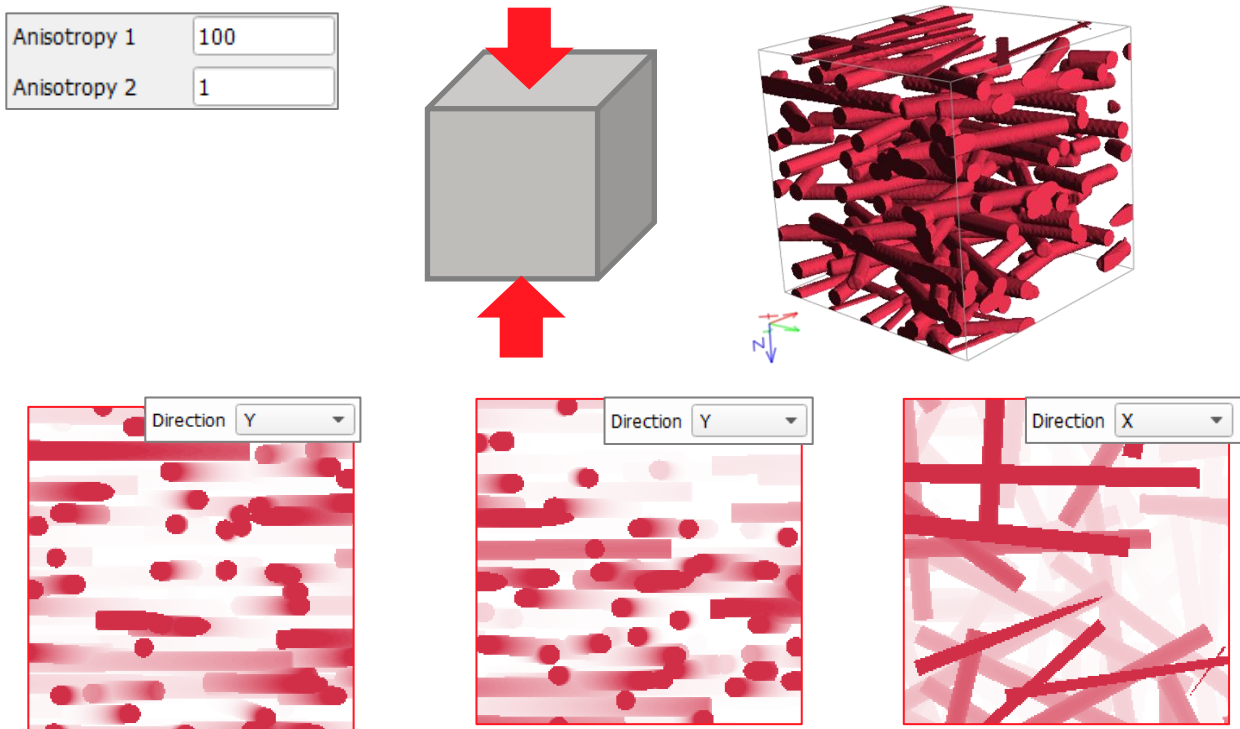

Anisotropy 1 = 1 and Anisotropy 2 < 1

Small values for Anisotropy 2 lead to fibers oriented parallel to the XZ-plane. Observe that the fibers are isotropic in the XZ-plane (Y-slice).

For example, with the values 1 for **Anisotropy 1** and 0.01 for **Anisotropy 2** it follows:

$$d_a = \begin{pmatrix} a_1 x \\ a_1 a_2 y \\ z \end{pmatrix} = \begin{pmatrix} x \\ 0.01 \cdot y \\ z \end{pmatrix}$$

Thus, after normalization the direction vectors of the fibers approximate the vector:

$$d_{normalized} = \frac{1}{\sqrt{x^2 + 0.0001 \cdot y^2 + z^2}} \begin{pmatrix} x \\ 0.01 \cdot y \\ z \end{pmatrix} \cong \begin{pmatrix} x \\ 0 \\ z \end{pmatrix}$$

That results in fibers oriented in the XZ-plane.

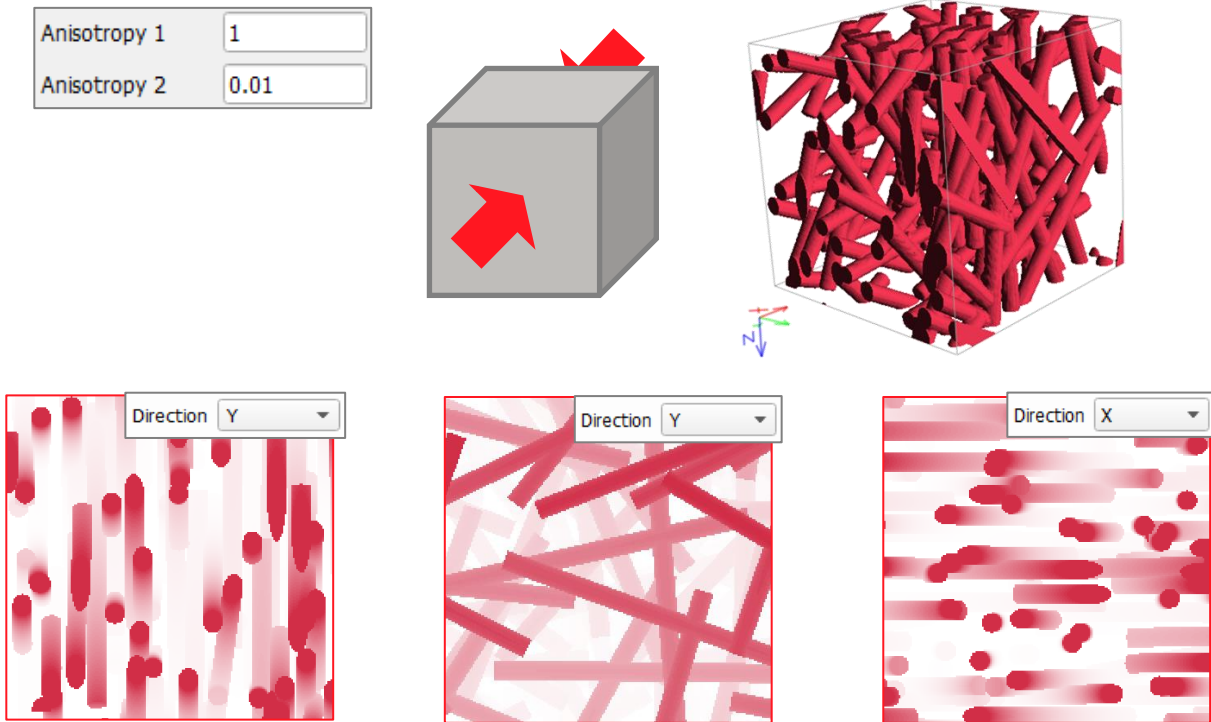

Anisotropy 1 = 1 and Anisotropy 2 > 1

The higher the values for **Anisotropy 2**, the more the fibers tend to be oriented along the Y-axis. Observe that the fibers cut the XZ-plane (Y-slice), while they run parallel to the YZ-plane and the XY-plane when viewing them from the X- or the Z-direction. For example, with the values 1 for **Anisotropy 1** and 100 for Anisotropy 2, it follows:

$$d_a = \begin{pmatrix} a_1x \\ a_1a_2y \\ z \end{pmatrix} = \begin{pmatrix} x \\ 100 \cdot y \\ z \end{pmatrix}$$

Thus, after normalization the direction vectors of the fibers approximate the unit vector:

$$d_{normalized} = \frac{1}{\sqrt{x^2 + 10000 \cdot y^2 + z^2}} \begin{pmatrix} x \\ 100 \cdot y \\ z \end{pmatrix} \cong \begin{pmatrix} 0 \\ 1 \\ 0 \end{pmatrix}$$

That results in fibers oriented in Y-direction.

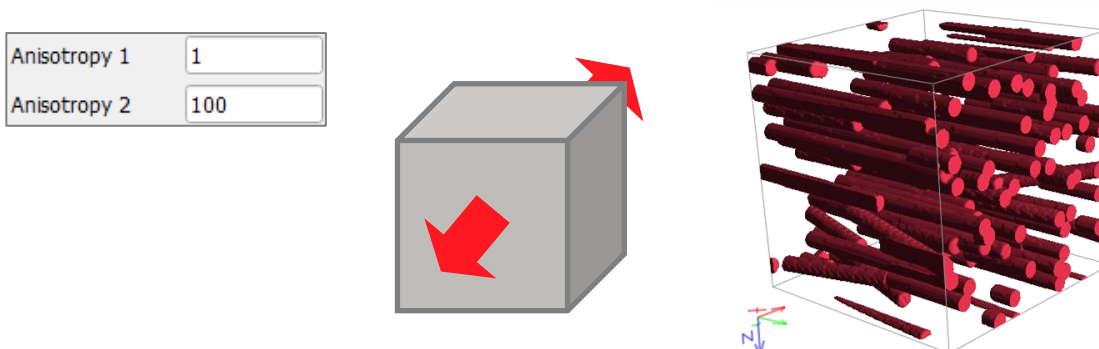

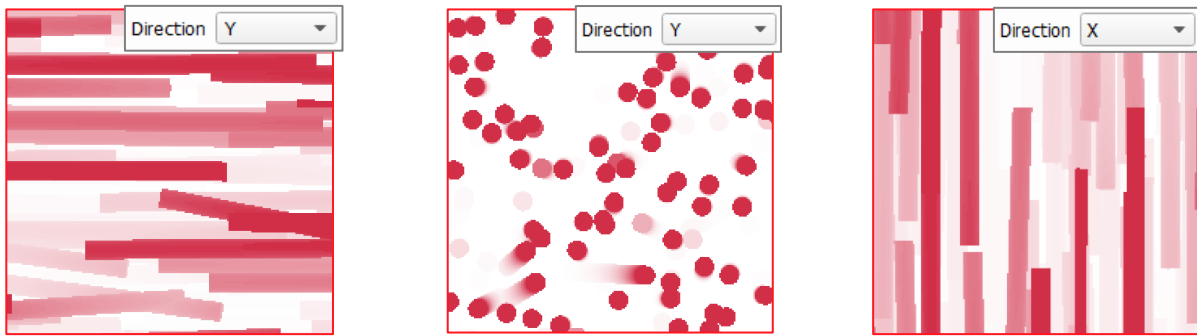

Different anisotropy values for different fiber types

As mentioned before, the orientation can be separately set for each fiber type so that differently oriented fibers may coexist within the same structure. In the following structure, observe that **Anisotropy 1** and **Anisotropy 2** are set to 0.01 and 1 for the infinite circular (red) fibers, whereas the short circular (grey) fibers have **Anisotropy 1** and **Anisotropy 2** of 1 and 100, respectively.

The red fibers tend to be oriented along the Z-axis, so that the fibers run parallel when viewed from the X- or Y-direction.

The grey fibers tend to be oriented along the Y-axis and cut the XZ-plane, while they run parallel to the YZ-plane and the XY-plane, as observed from the X- or the Z-direction.

Infinite Circular	
Material (ID 01)	Manual (Solid) ...
Anisotropy 1	0.01
Anisotropy 2	1
Short Circular	
Material (ID 02)	Manual (Solid) ...
Anisotropy 1	1
Anisotropy 2	100

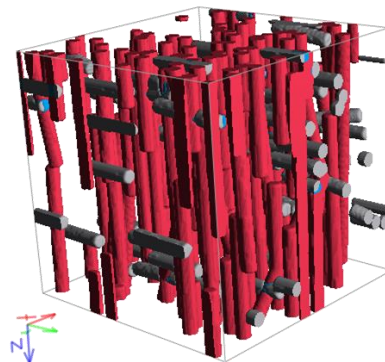

Center

Diameter / (μm)	12	Edit ...
Length / (μm)	50	Edit ...
Orientation	<Isotropic>	Edit ...
Center / (μm)	<Uniformly Distributed>	Edit ...
<input type="checkbox"/> Rounded Endings		
<input type="checkbox"/> Couple Diameter / Dtex and Length		

The position of short and curved fibers in a generated structure can be controlled by adjusting the position of their **Center** through the **Edit...** button.

The **Center** of the fibers may be distributed Uniformly, Uniformly in Box, or follow a Density Distribution.

Uniformly

When **Uniformly** is checked, the random fiber center values are uniformly distributed across the whole structure. The uniform distribution of the centers is clearly observed when the fibers in the structure are fairly short circular fibers.

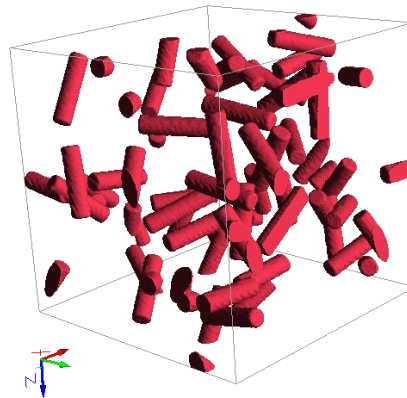
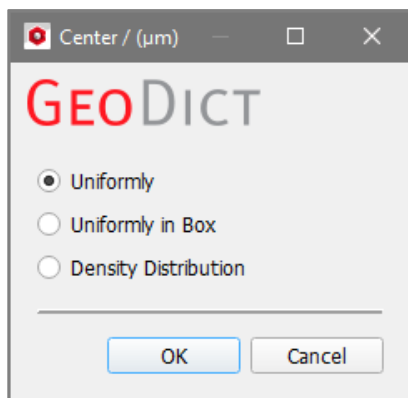

On Current Objects

The option to position the centers **On Current Objects** appears in the **Center** dialog only when **Create in Current Domain** is checked under the **Create Options** tab (see pages [5ff.](#)).

Observe the placement of short circular fibers' centers on the loaded **Cone.gad** structure (generated with **GadGeo**), when **On Current Objects** is chosen in the **Center** dialog.

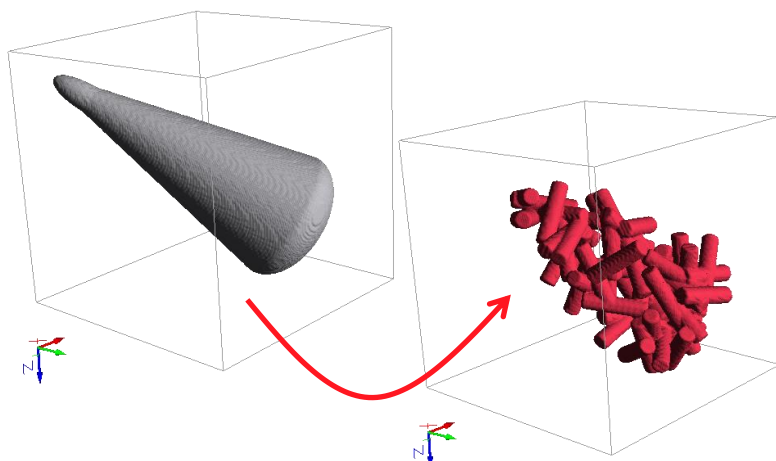
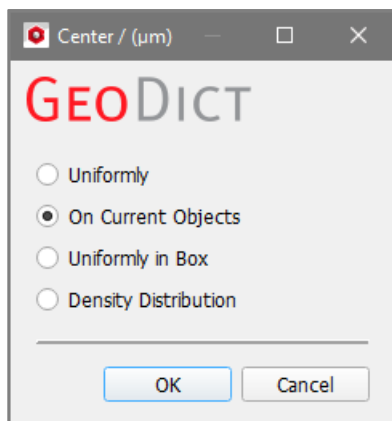

Uniformly in Box

With **Uniformly in Box** checked, the values entered for **X-min**, **X-max**, **Y-min**, **Y-max**, **Z-min** and **Z-max**, limit the distribution of the center's positions to certain areas.

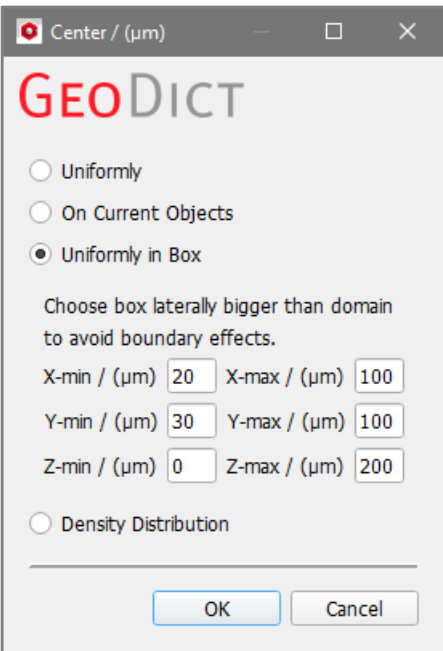

These directionally limiting values define an area in which the fiber centers are placed. For a 200 x 200 x 200 µm structure, the values on the left dialog limit an area in which the fibers' centers lay between 20 µm and 100 µm in the X-direction, 30 µm and 100 µm in the Y-direction, and between the origin (0 µm) and the end of the domain in the Z-direction.

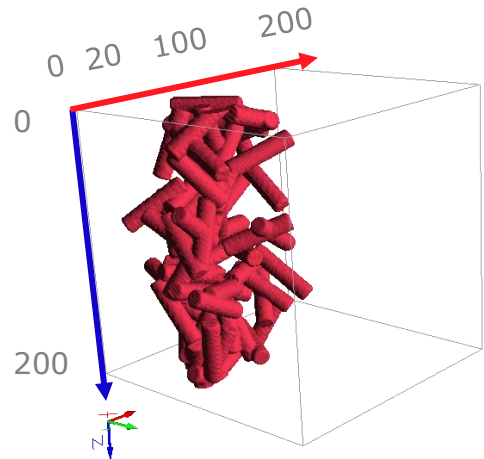

Density Distribution

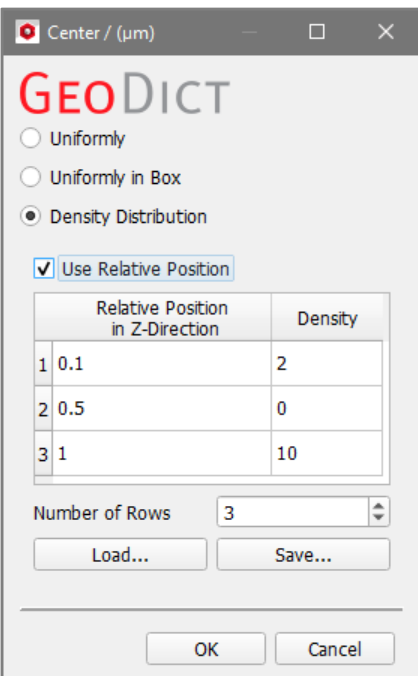

The **Density Distribution** table describes the probability of a random center taking certain position values in Z-direction.

When checking **Use Relative Position**, in the density distribution table, the left column values from 0 to 1 correspond to locations in the structure. In the Z-direction, the value 0 is at the origin and the value 1 is at end of the domain. The right column assigns relative density values at these locations. The value **10** means that there are five times more fiber centers at Z = 1 than at Z = 0.1, with a density value of **2**. The fiber density increases and decreases linearly between the given locations in the Z-direction.

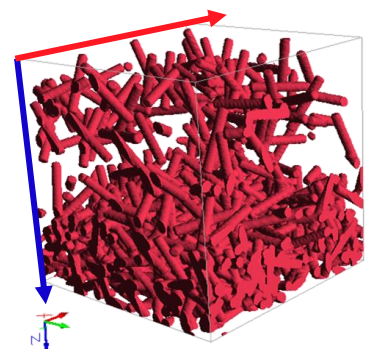

Observe how, with the values in this table, some fibers occupy the area near the Z origin (Z=0.1), then there is an area almost empty of fibers in the middle (Z=0.5), and most fibers are at the bottom in Z-direction (Z = 1).

With **Use Relative Position** un-checked, the left column values of the density distribution table correspond to absolute locations in the structure.

In the Z-direction, in a structure of size 200 x 200 x 200 μm , the value 0 is at the origin and the value 200 is at end of the domain. The right column assigns density values at these locations, where **0** means that fiber centers are absent at that location, and **1** means that fiber centers are present at the location.

Observe how, with the values in these tables, fibers are absent or appear at the given locations. The fiber density increases and decreases linearly between the given locations in the Z-direction.

	Absolute Position in Z-Direction / (μm)	Density
1	0	0
2	10	1
3	50	1
4	50	0
5	200	0

Number of Rows: 5

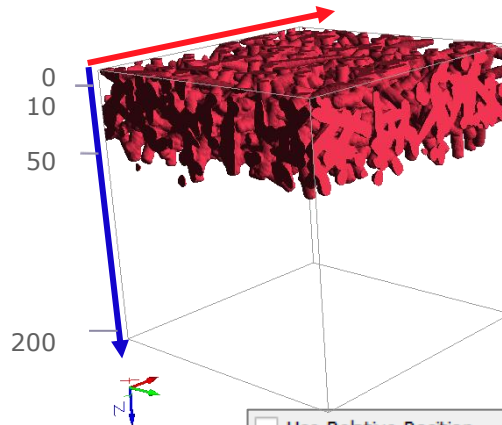

	Absolute Position in Z-Direction / (μm)	Density
1	0	0
2	150	0
3	150	1
4	175	1
5	175	0
6	200	0

Number of Rows: 6

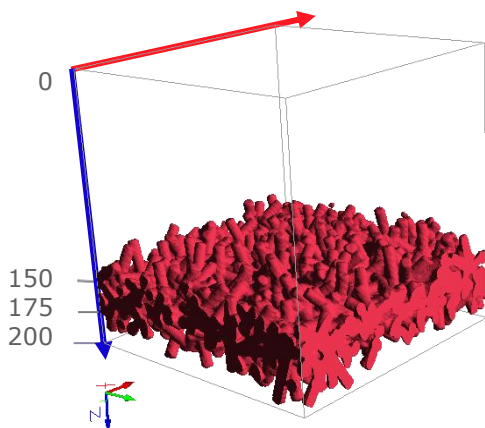

	Absolute Position in Z-Direction / (μm)	Density
1	0	0
2	30	0
3	30	2
4	75	2
5	75	0
6	150	0
7	150	20
8	175	20
9	175	0
10	200	0

Number of Rows: 10

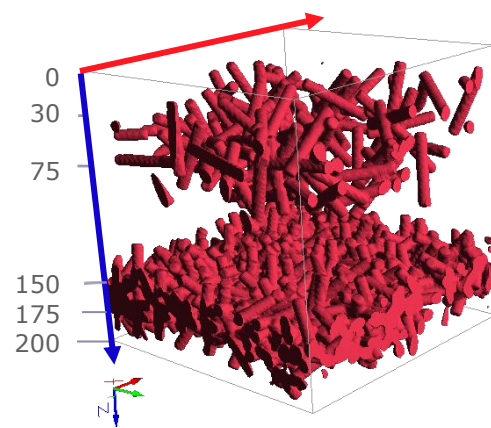

The same structures can be obtained when using or not using relative positions, as seen in the following example. Both structures are based on the same random seed.

Use Relative Position

Absolute Position in Z-Direction / (μm)		Density
1	0	0
2	30	0
3	30	1
4	75	1
5	75	0
6	150	0
7	150	1
8	175	1
9	175	0
10	200	0

Number of Rows

Use Relative Position

Relative Position in Z-Direction		Density
1	0	0
2	0.15	0
3	0.15	1
4	0.375	1
5	0.375	0
6	0.75	0
7	0.75	1
8	0.875	1
9	0.875	0
10	1	0

Number of Rows

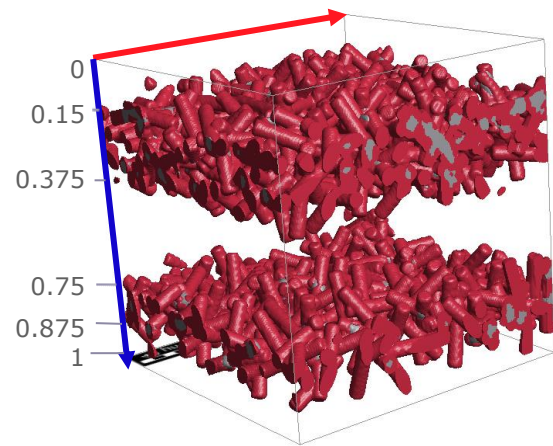
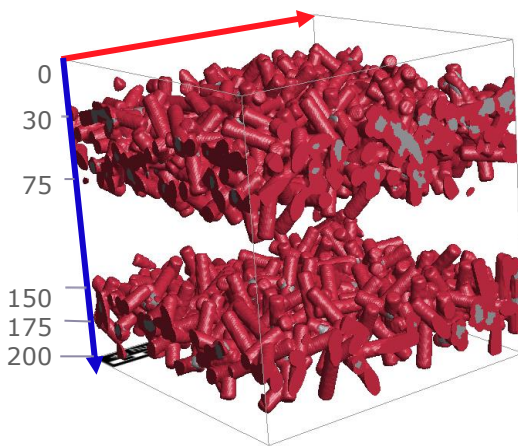

The center density distribution must be defined with monotonously increasing z-values. If z is non-monotonic or monotonously decreasing, an error message appears when trying to generate the structure.

Use Relative Position

Relative Position in Z-Direction		Density
1	0	0
2	0.5	2
3	0.2	0
4	1	10

Number of Rows

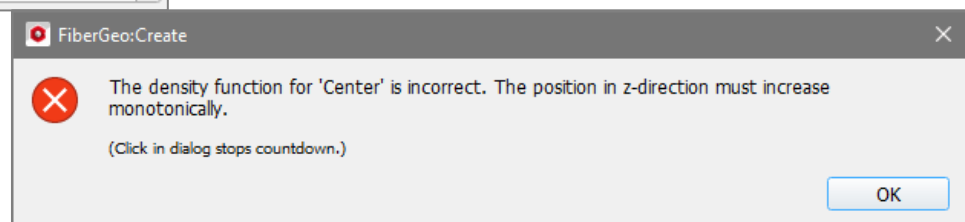

As before with orientation, the distribution of centers can be separately set for each fiber type so that differently distributed fiber types may coexist within the same structure. In the following structures, observe that the grey short circular fibers are distributed **Uniformly in Box**, whereas the red short circular fibers follow a **Density Distribution**.

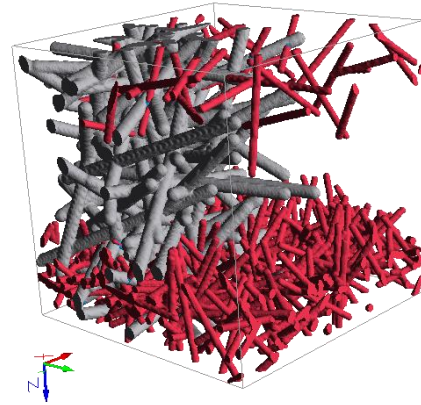
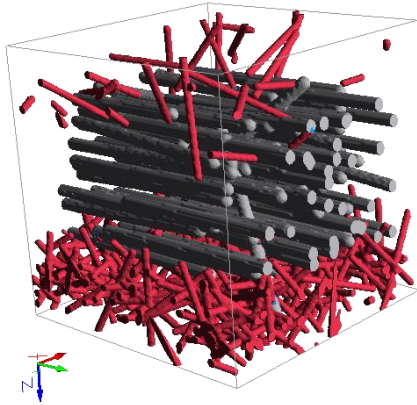

Curl Parameters

If the fibers added to the structure are **curved fibers**, a **Curl** tab appears in the right panel. Curved fibers can bend in four modes, selectable in the **Curl Mode** pull-down menu: **Spiral**, **Sine**, **Random** and **Curvature**. The curl parameters are different for these modes. The default mode is **Random**.

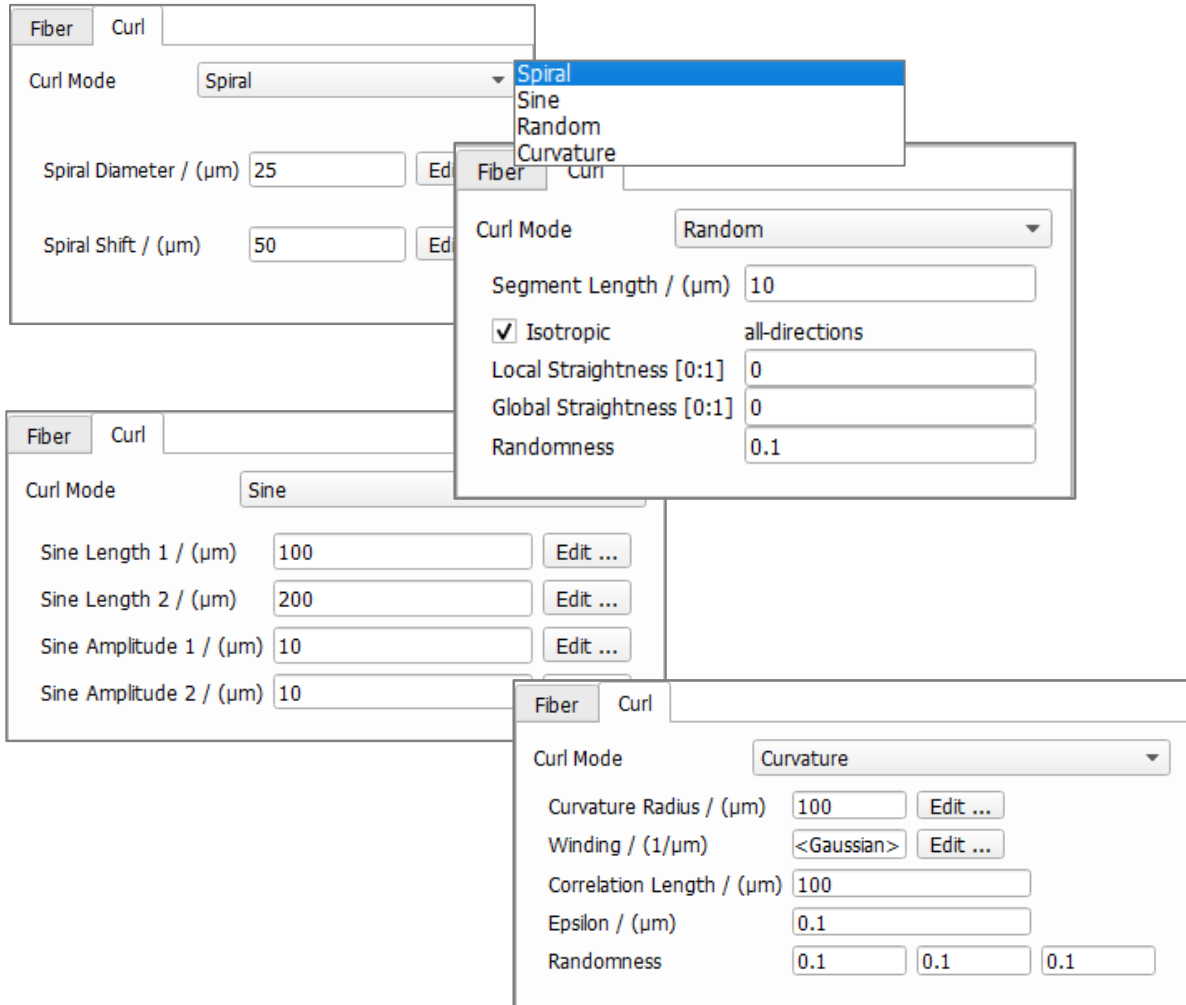

Spiral

Spiral curved fibers form a three-dimensional curve that winds around an axis. The spirals are defined by the **Spiral Diameter** and the **Spiral Shift**. The spiral shift is the distance between the same relative positions in two consecutive loops of the spiral.

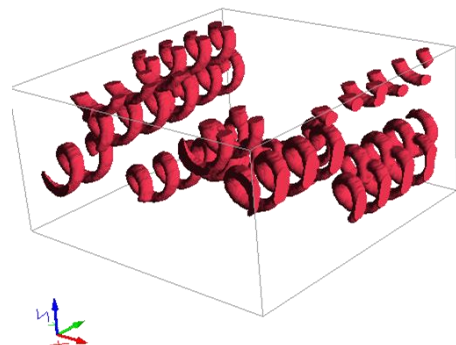
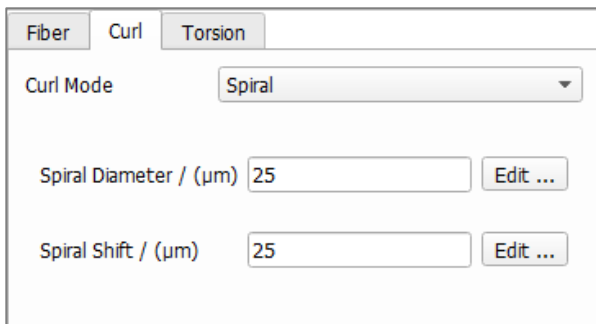

Observe the effect that changing these two parameters has on the form of the generated spiral curved fibers.

Fiber	Curl	Torsion
Curl Mode	Spiral	
Spiral Diameter / (μm)	50	Edit ...
Spiral Shift / (μm)	25	Edit ...

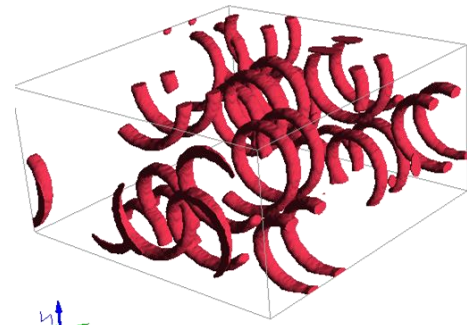

Fiber	Curl	Torsion
Curl Mode	Spiral	
Spiral Diameter / (μm)	25	Edit ...
Spiral Shift / (μm)	50	Edit ...

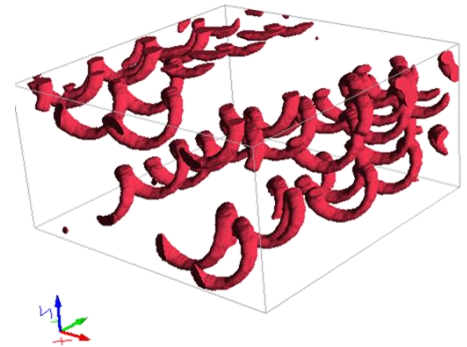

Sine

Sine (sinusoidal) curved fibers follow a sinusoid curve defined by the equation

$$y = \sin x.$$

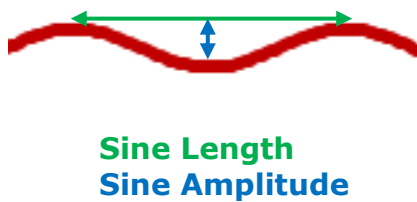

Fiber	Curl	
Curl Mode	Sine	
Sine Length 1 / (μm)	100	Edit ...
Sine Length 2 / (μm)	200	Edit ...
Sine Amplitude 1 / (μm)	10	Edit ...
Sine Amplitude 2 / (μm)	10	Edit ...

For sine curved fibers, the parameters **Sine Length 1**, **Sine Length 2**, **Sine Amplitude 1**, and **Sine Amplitude 2** are determined by the fiber orientation. **Sine Amplitude 1** and **Sine Amplitude 2** describe the oscillation amplitude in the direction of the main axis. This is shown below for an elliptical fiber.

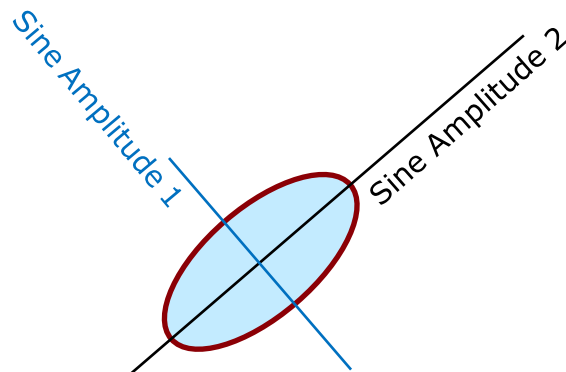
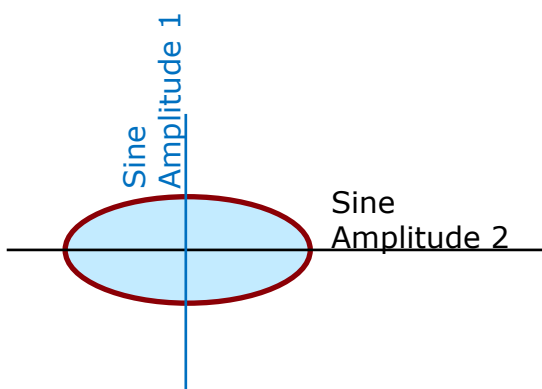

Initially, keep the default values of **Sine Length 1**, and **Sine Length 2**, whereas the **Sine Amplitude 1** and **Sine Amplitude 2** are set to 0, as is the **Torsion Start Angle**. These parameters produce straight fibers.

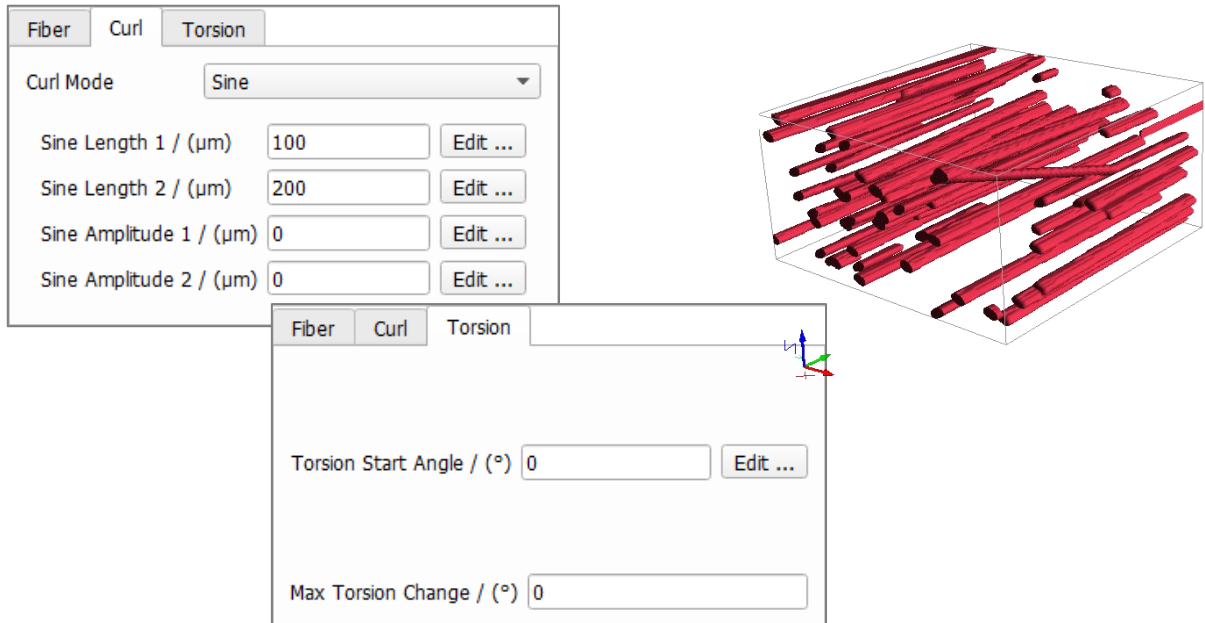

When the same fibers are created with a smaller **Sine Length 2** (75 μm) and a **Sine Amplitude 2** of 10 μm, the sine fibers appear curved.

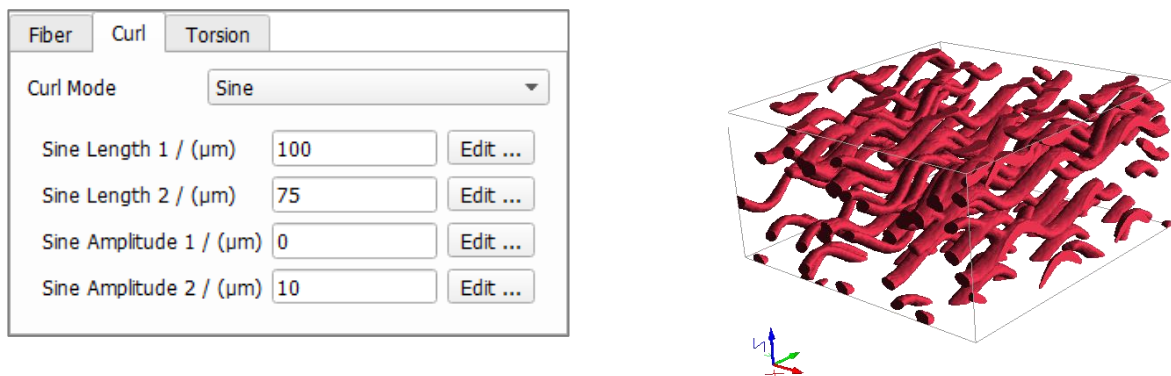

When these same curved sine fibers are created with a **Torsion Start Angle** that follows a uniform distribution in the interval 0 to 90°, the sine fibers appear curved and twisted.



Sine fibers have only one sinusoidal component when the **Sine Amplitude 1** (or **Sine Amplitude 2**) is 0, while the other sine amplitude is set to a positive value. Sine fibers with a combination of components are obtained when both sine amplitudes are set to positive values. For example, with the following values:

Fiber	Curl	Torsion
Curl Mode Sine		
Sine Length 1 / (μm)	100	<input type="button" value="Edit ..."/>
Sine Length 2 / (μm)	75	<input type="button" value="Edit ..."/>
Sine Amplitude 1 / (μm)	0	<input type="button" value="Edit ..."/>
Sine Amplitude 2 / (μm)	10	<input type="button" value="Edit ..."/>

Fiber	Curl	Torsion
Curl Mode Sine		
Sine Length 1 / (μm)	100	<input type="button" value="Edit ..."/>
Sine Length 2 / (μm)	75	<input type="button" value="Edit ..."/>
Sine Amplitude 1 / (μm)	10	<input type="button" value="Edit ..."/>
Sine Amplitude 2 / (μm)	10	<input type="button" value="Edit ..."/>

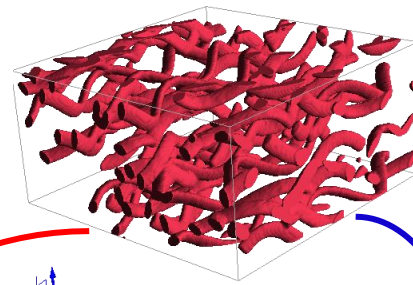
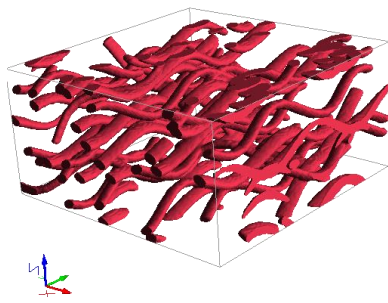

Random

Curved **Random** fibers consist of straight fiber segments of a given **Segment Length**. Its value determines the length of the linear parts that build the fiber, so that small values lead to well resolved fibers with smooth curving. A large segment length leads to fibers with long straight segments.

Fiber	Curl	Torsion
Curl Mode Random		
Segment Length / (μm)	10	<input type="button" value="Edit ..."/>
<input checked="" type="checkbox"/> Isotropic	All-Directions	
Local Straightness [0:1]	0	<input type="button" value="Edit ..."/>
Global Straightness [0:1]	0	<input type="button" value="Edit ..."/>
Randomness	0.1	<input type="button" value="Edit ..."/>

In the following examples, all parameters are left unchanged while curved circular fibers with a length of 100 μm are given varying **Segment Length**, as indicated.

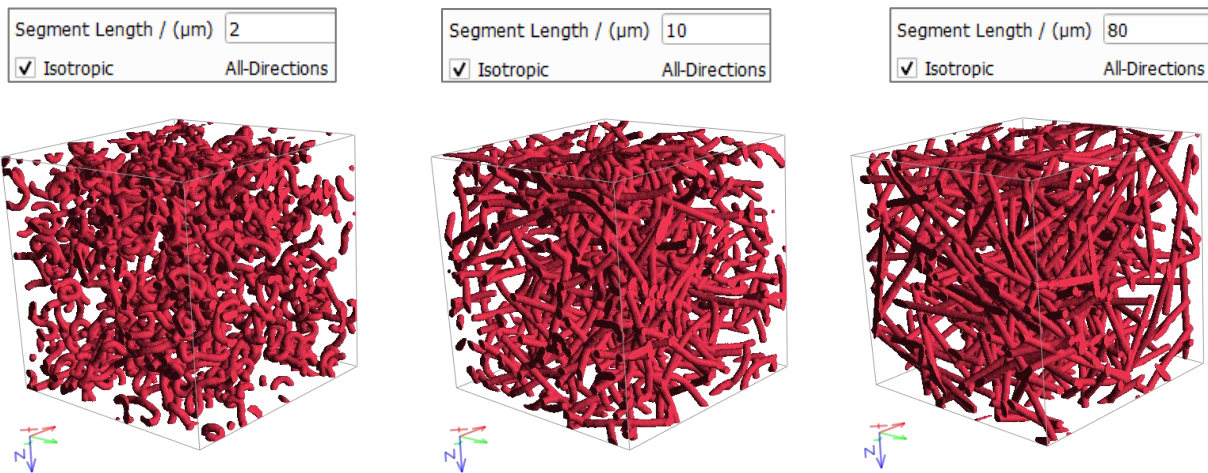

The first segment is placed in space according to the **Center** and **Orientation** values defined under the **Fiber** tab. The curved fiber follows a **main fiber direction** given by this orientation value (Anisotropy 1 and Anisotropy 2). The first segment is the middle segment. The other segments are attached to both ends according to the Straightness and Randomness parameters.

The checking or un-checking of **Isotropic** controls the direction in which the parameters **Local Straightness**, **Global Straightness**, and **Randomness** are applied to the new segment. These parameter values (between 0 and 1) define the direction of each newly attached segment and determine how strongly a fiber may change direction from one segment to the next.

Randomness corresponds to the standard deviation (σ) of the Gaussian distribution ($G_\sigma(0)$) with mean value 0. The direction of the new segment (d_{n+1}) is determined by the following rule:

$$d_{n+1} = \beta d + (1 - \beta)d_n + (1 - \alpha)(d_n - d_{n-1}) + G_\sigma(0),$$

where

- d : main direction of the fiber (orientation applied on first segment),
- d_n : direction of the current segment,
- d_{n-1} : direction of the last segment,
- α : Local Straightness
- β : Global Straightness

For the shape of the fiber, there are four main cases considering the parameters for local and global straightness (α and β). The impact of these parameters on each new segment is explained below.

The blue segment is the center segment which is the first segment placed according to the parameters for orientation (d) and center defined in the Fiber tab. The red dotted line would be the new segment for $G_\sigma(0) = 0$, as the Randomness value ($G_\sigma(0)$) controls the width of the red area.

1. $\alpha = 1, \beta = 0$: The previous direction is kept, i.e. the fiber tends to be locally straight.

$$d_{n+1} = d_n + G_\sigma(0)$$

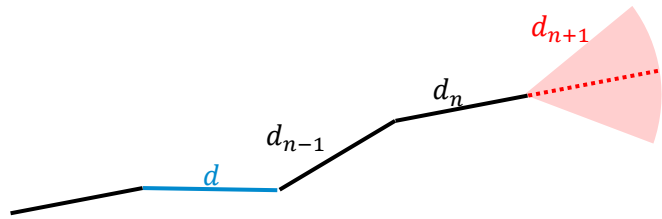

2. $\alpha = 1, \beta = 1$: The main fiber direction is kept, i.e. the fiber tends to be globally straight.

$$d_{n+1} = d + G_\sigma(0)$$

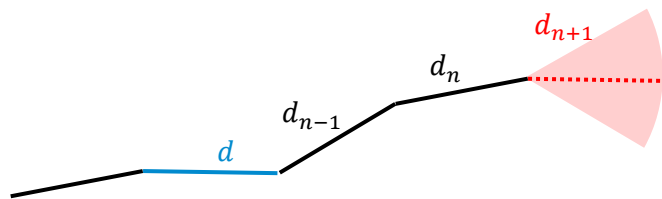

3. $\alpha = 0, \beta = 0$: The previous curvature is kept.

$$(d_{n+1} - d_n) = (d_n - d_{n-1}) + G_\sigma(0)$$

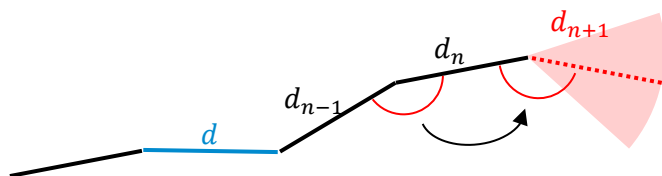

4. $\alpha = 0, \beta = 1$: The angle between the current and the last segment, defined by the previous curvature, is considered for the attachment of the new segment. This angle is applied between the direction of the new segment and the main direction, i.e. the fiber always bends with respect to the main direction. Thus, it tends to be globally straight, while the local curvature is taken into account.

$$(d_{n+1} - d) = (d_n - d_{n-1}) + G_\sigma(0)$$

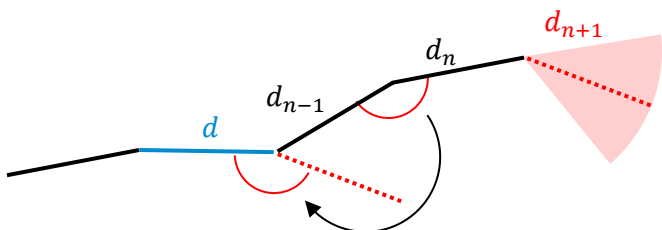

Observe the effect of varying **Local Straightness**, **Global Straightness** and **Randomness** on a structure made of highly anisotropic (oriented in the Z-axis, **Anisotropy 1** = 0.001, **Anisotropy 2** = 1) curved circular fibers. All other parameters remain unchanged.

With **Randomness** set to zero, all segments have the same direction, resulting in straight fibers.

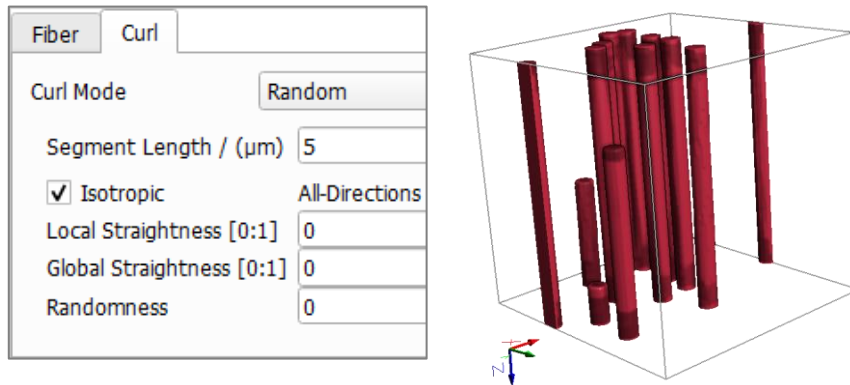

With a slightly higher **Randomness** value (0.01), curvature is introduced. With **Global Straightness** and **Local Straightness** set to 0, the predefined orientation is only applied to the initial segment and the curvature differs not much between adjacent segments, leading to spiral-like curves.

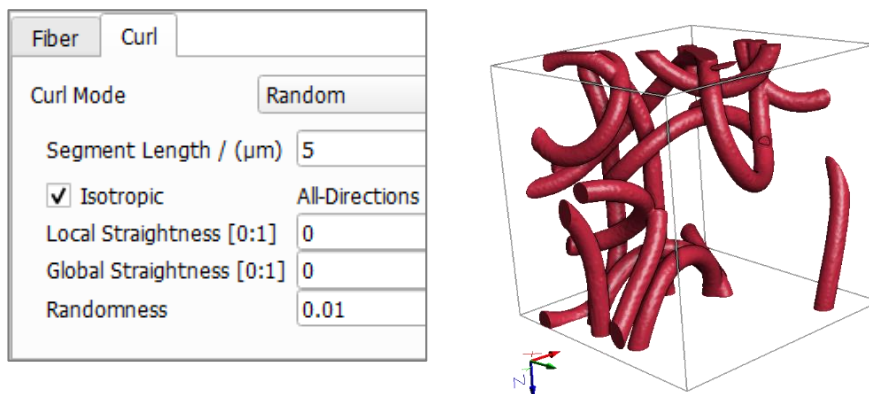

The fiber curvature increases with the **Randomness** value.

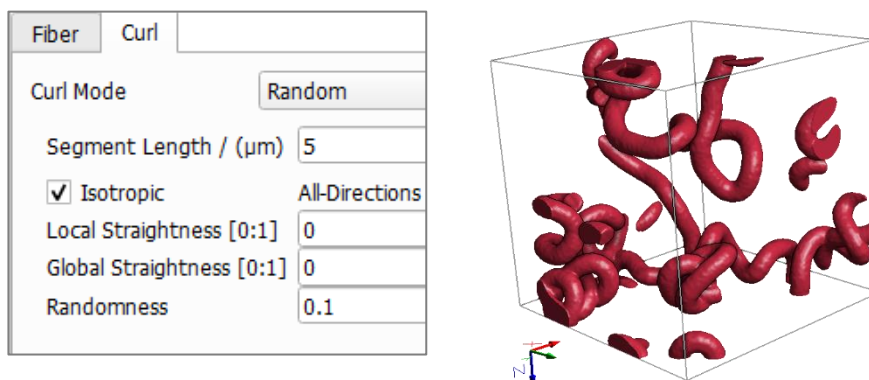

The **Straightness** values can be set between 0 and 1. The higher the value for **Global Straightness** the more the fiber tends towards the main direction.

With a non-zero **Global Straightness** value, the fibers tend to return to the initial prescribed **Orientation**.

Fiber		Curl	
Curl Mode		Random	
Segment Length / (μm)	5		
<input checked="" type="checkbox"/> Isotropic	All-Directions		
Local Straightness [0:1]	0		
Global Straightness [0:1]	0.5		
Randomness	0.1		

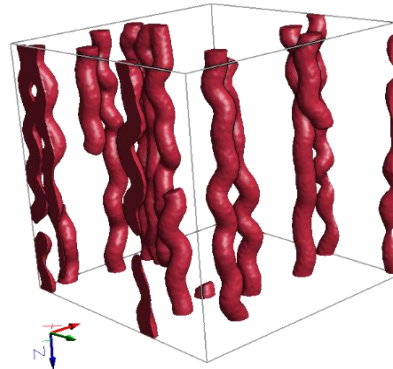

With a **Global Straightness** value of 1, the fibers globally keep the **Orientation**, while a **Local Straightness** of 0 leads to fibers locally keeping curvature.

Fiber		Curl	
Curl Mode		Random	
Segment Length / (μm)	5		
<input checked="" type="checkbox"/> Isotropic	All-Directions		
Local Straightness [0:1]	0		
Global Straightness [0:1]	1		
Randomness	0.1		

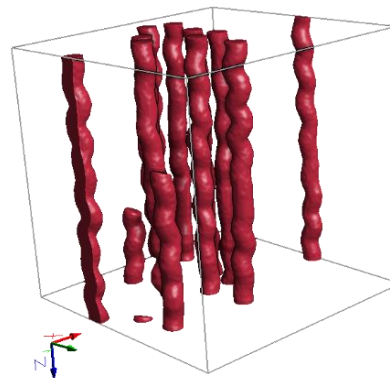

The higher the value for **Local Straightness** the smoother the curves, as the local directions tend to be kept. If the **Global Straightness** value is 0, the fibers are not restrained to stay in the predefined Orientation.

A non-zero value of **Local Straightness** results in a reduction of the fibers' curvature (compared to the structure with Local Straightness of 0 above).

Fiber		Curl	
Curl Mode		Random	
Segment Length / (μm)	5		
<input checked="" type="checkbox"/> Isotropic	all-directions		
Local Straightness [0:1]	0.5		
Global Straightness [0:1]	0		
Randomness	0.1		

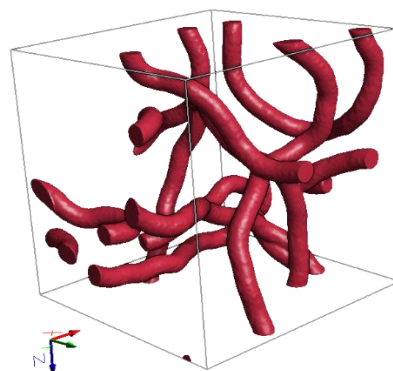

A **Local Straightness** value of 1 leads to low curvature and straighter fibers.

Fiber		Curl	
Curl Mode		Random	
Segment Length / (μm)	5		
<input checked="" type="checkbox"/> Isotropic	All-Directions		
Local Straightness [0:1]	0		
Global Straightness [0:1]	0		
Randomness	0.1		

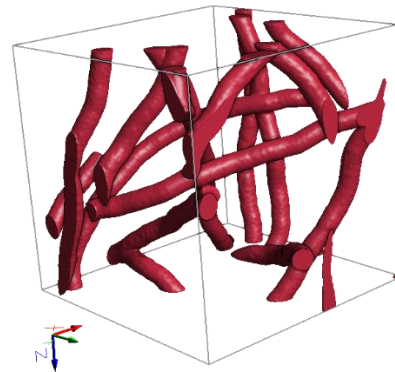

A higher **Global Straightness** value, with a **Local Straightness** value of 1, results in almost straight fibers keeping the main direction.

Fiber		Curl	
Curl Mode		Random	
Segment Length / (μm)	5		
<input checked="" type="checkbox"/> Isotropic	All-Directions		
Local Straightness [0:1]	1		
Global Straightness [0:1]	0.5		
Randomness	0.1		

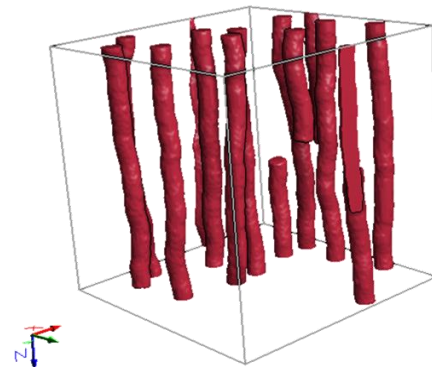

The Curl Parameters are **Isotropic** by default. Alternatively, anisotropic curl parameters can be defined. This is done by unchecking **Isotropic** and entering the parameters for each direction (X, Y and Z) separately. Setting anisotropic curl parameters makes sense only in combination with an anisotropic fiber orientation.

Here, the same curl parameter values are entered for the X- and Y-directions, whereas no deformation is allowed in Z-direction, where **Local Straightness** and **Global Straightness** have been set to 1 and **Randomness** to 0.

Fiber		Curl		
Curl Mode		Random		
Segment Length / (μm)	5			
<input type="checkbox"/> Isotropic	X-Direction	Y-Direction	Z-Direction	
Local Straightness [0:1]	0.8	0.8	1	
Global Straightness [0:1]	0.6	0.6	1	
Randomness	0.3	0.3	0	

In this example, observe how the deformation of curved circular fibers occurs only in the XY-plane of an anisotropic-oriented structure (**Anisotropy 1** =100 and **Anisotropy 2** =1) when entering the anisotropic curl parameters shown above.

With values of Anisotropy 1 and Anisotropy 2 being 100 and 1, the generated fibers are oriented perpendicular to the Z-axis.

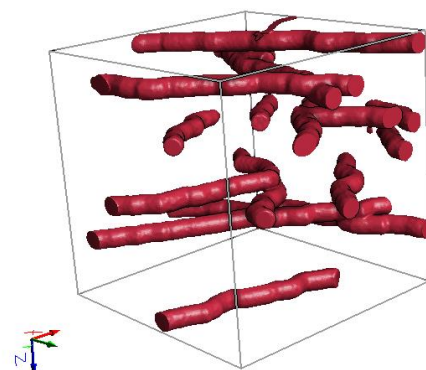

Views from the X- and the Y-direction show that there is no deformation of fibers in Z-direction. This is a consequence of setting the **Randomness** in Z-direction to zero.

The view from the Z-direction shows that the fibers are curved in the X and Y directions.

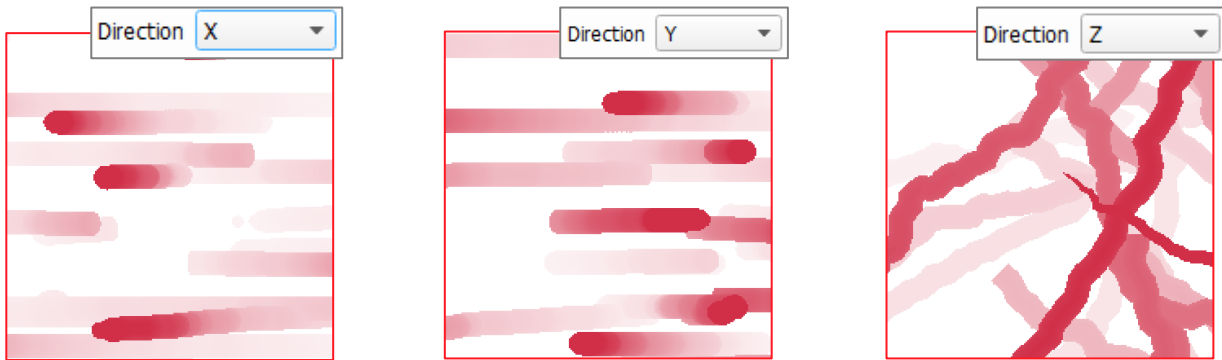

Curvature

The **Curvature** is an experimental feature and is only selectable for curved circular, curved hollow, curved rosetta, and curved angular fibers.

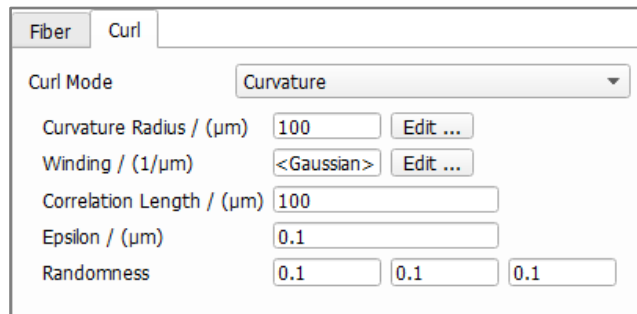

The **Curvature Radius** controls the radius of the spiral followed by the fiber. Choosing the values of **Randomness** and **Winding** to be 0 leads to loops with the radius defined by Curvature Radius. **Winding** controls the distance between each spiral loop. Lower winding values lead to shorter distances between the loops.

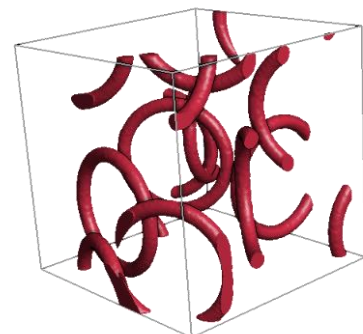
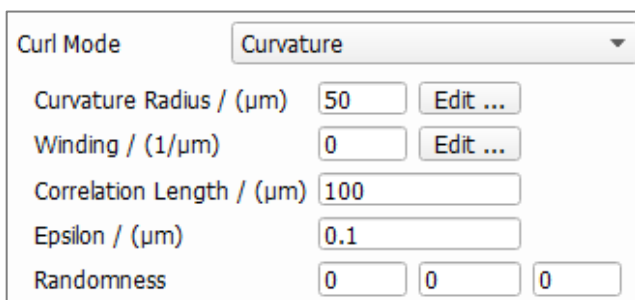
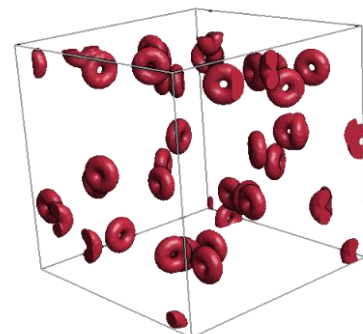
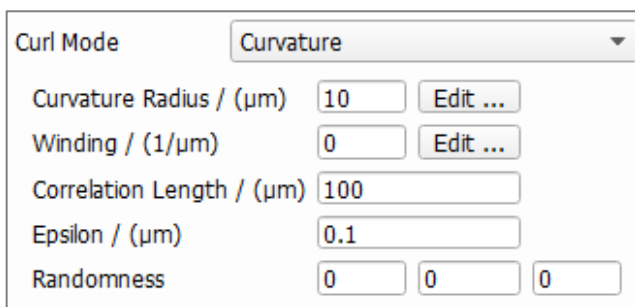

The **Correlation Length** defines the length of the fiber section for which **Curvature Radius** and **Winding** are applied. For each of those sections, these parameters are applied anew. If none of the two parameters is set to a random distribution, the Correlation Length has no impact.

In the example below, the **Curvature Radius** is deviated uniformly between 10 and 50. The winding is set to the constant value 0.1. With a **Correlation Length** of 50 each spiral is different but with a **Correlation Length** of 100 the spirals with small radius are repeated. As the Winding is kept constant, the Correlation Length is only applied to the Curvature Radius.

Curl Mode	Curvature		
Curvature Radius / (μm)	[10,50]>	Edit ...	
Winding / ($1/\mu\text{m}$)	0.01	Edit ...	
Correlation Length / (μm)	100		
Epsilon / (μm)	0.1		
Randomness	0	0	0

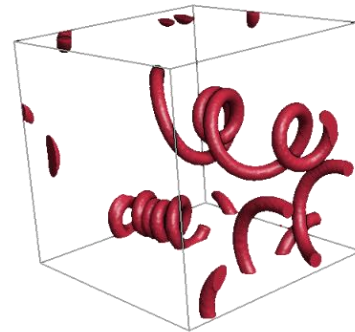

Curl Mode	Curvature		
Curvature Radius / (μm)	[10,50]>	Edit ...	
Winding / ($1/\mu\text{m}$)	0.01	Edit ...	
Correlation Length / (μm)	50		
Epsilon / (μm)	0.1		
Randomness	0	0	0

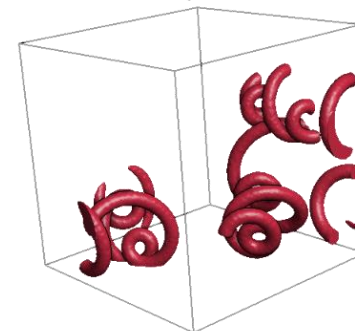

The **Epsilon** parameter controls the segment length but is recommended to keep the default value 0.1.

The higher the **Randomness** value, the stronger are the changes of curvature radius and winding in each section. Setting Randomness = 0 creates loops and spirals.

Curl Mode	Curvature		
Curvature Radius / (μm)	25	Edit ...	
Winding / ($1/\mu\text{m}$)	0.01	Edit ...	
Correlation Length / (μm)	100		
Epsilon / (μm)	0.1		
Randomness	0.01	0.01	0.01

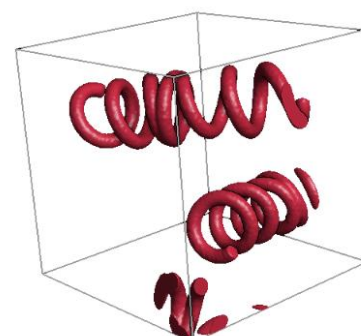

Curl Mode	Curvature		
Curvature Radius / (μm)	25	Edit ...	
Winding / ($1/\mu\text{m}$)	0.01	Edit ...	
Correlation Length / (μm)	100		
Epsilon / (μm)	0.1		
Randomness	0.1	0.1	0.1

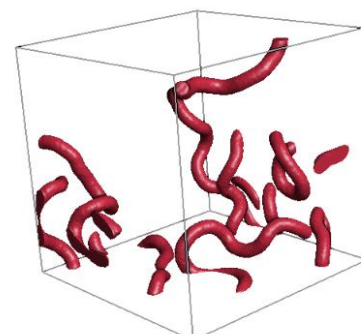

Torsion Parameters: Torsion Start Angle and Maximum Torsion Change

Curved **Rectangular**, **Elliptical** and **Cellulose** fibers can be internally spun to achieve torsion, when entering adequate values for **Torsion Start Angle** and **Max Torsion Change**.

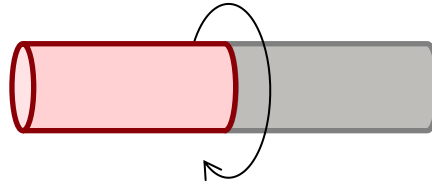

The **Torsion Start Angle** defines how strongly the fibers are twisted within the first segment length.

The **Maximum Torsion Change** determines the maximum allowed degree of change of the **Torsion Angle** from one segment to the next. The torsion change between different segments is uniformly distributed.

Observe the effect of varying the torsion parameters on a highly anisotropic structure (**Anisotropy 1** = 0.001, **Anisotropy 2** = 1) made of curved ellipsoidal fibers. The curl parameters are **Isotropic**, and **Randomness** is 0, producing straight fibers parallel to the Z-axis.

Both **Torsion Start Angle** and **Max Torsion Change** values are initially set to 0 in the **Torsion** panel to generate fibers without torsion.

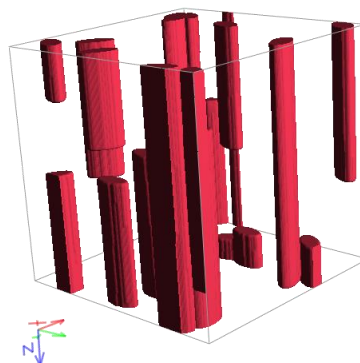

With **Torsion Start Angle** values of 5, 30, and 45, and a **Max Torsion Change** value of 0, fibers with a constant spin of 5°, 30° and 45° within each segment are generated.

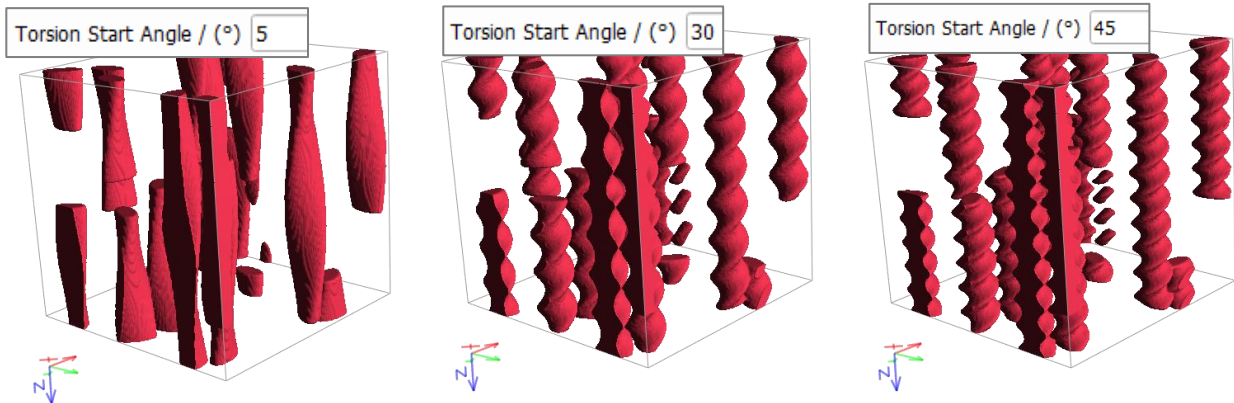

The use of **Max Torsion Change** adds a random component the torsion angle. The torsion change angle is drawn from a uniform distribution with the limits $[-\text{Max Torsion Change}, \text{Max Torsion Change}]$ and added to the current torsion angle.

Observe the effect of keeping a **Torsion Start Angle** of 0 and entering increasing values of **Maximal Torsion Change** (5, 10 and 30) on a highly anisotropic structure made of curved cellulose fibers.

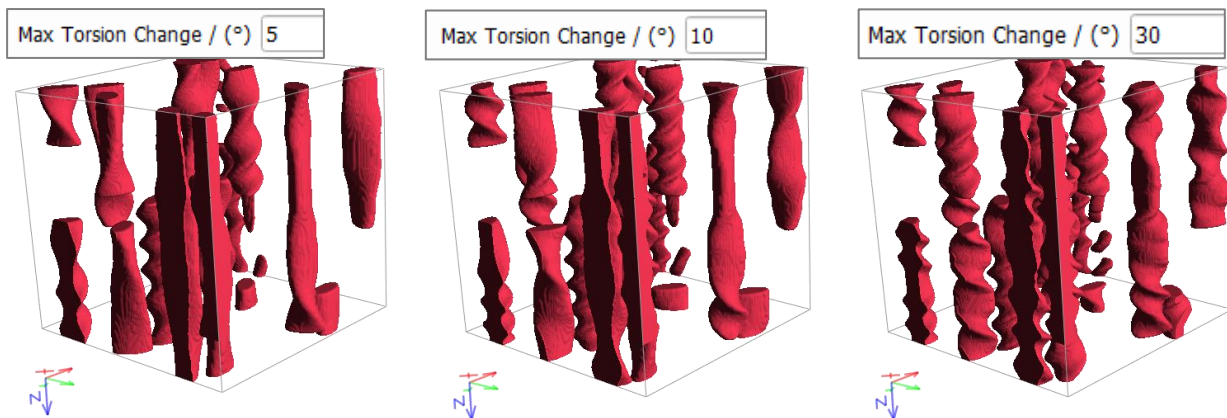

FIBER OVERLAP

The options under the **Fiber Overlap** tab define the material IDs in locations where materials in the structure overlap. The overlap locations can have other properties than the original materials.

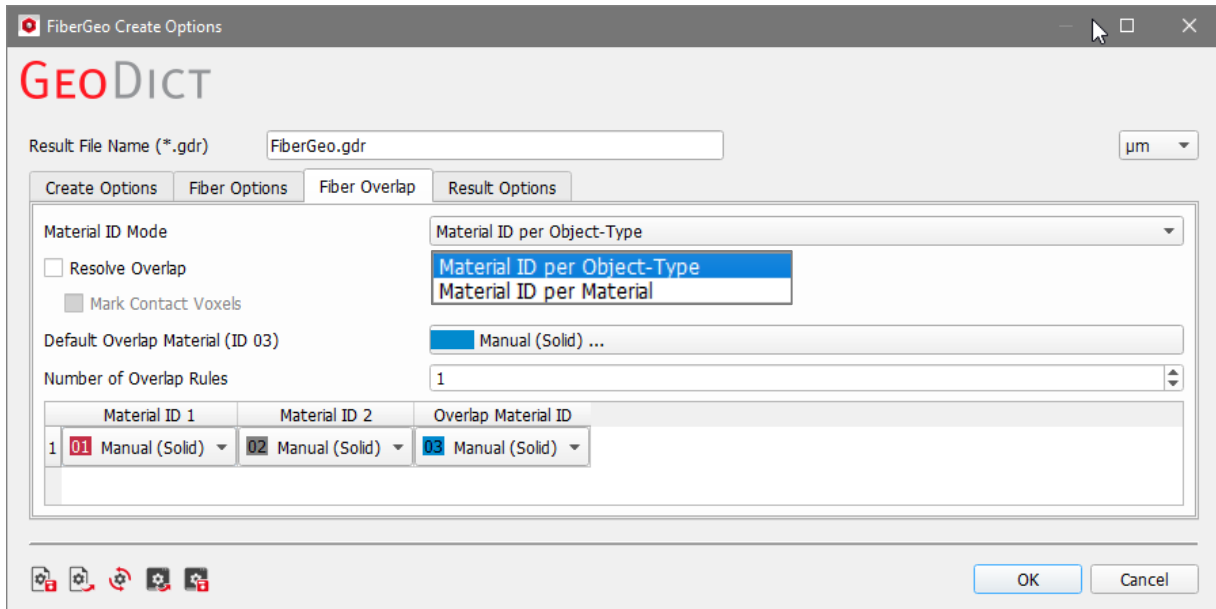

The **Material ID Mode** pull-down menu allows to select between two modes. **Material ID per Material** means that all objects with the same material receive the same **Material ID**. **Material ID per Object-Type** means that objects with different type (e.g. different fiber types) obtain different **Material IDs**, even if they are made of the same material.

If **Resolve Overlap** is checked, the overlap is not assigned to a new material ID. Instead, the water-shed algorithm is used to decide which of the overlap voxels belongs to which object in a post-processing step. Thus, each overlap voxel is assigned to one specific object. This option needs more memory and a longer run-time.

In detail, the **Resolve Overlap** algorithm starts with computing a distance map for the overlap voxels, i.e. it computes the distance to the next object for each overlap voxel. On this distance map the watershed algorithm is run using all voxels belonging to an object as seeds. There, all voxels contained in the same object have the same material ID. Thus, the overlap area is filled with the object IDs according to the distance map.

To mark the contact voxels between the objects with a separate material ID, select **Mark Contact Voxels** and choose a **Contact Material** from the Material Data Base. The voxels, where two or more object IDs meet, are marked as contact voxels, by reassigning them with a new material ID. Thus, the layer of contact voxels always has a thickness of two voxels.



In the following observe the resulting Material IDs for the overlap for not resolved, resolved, and resolved overlap with marked contact voxels, while all other settings are kept the same.

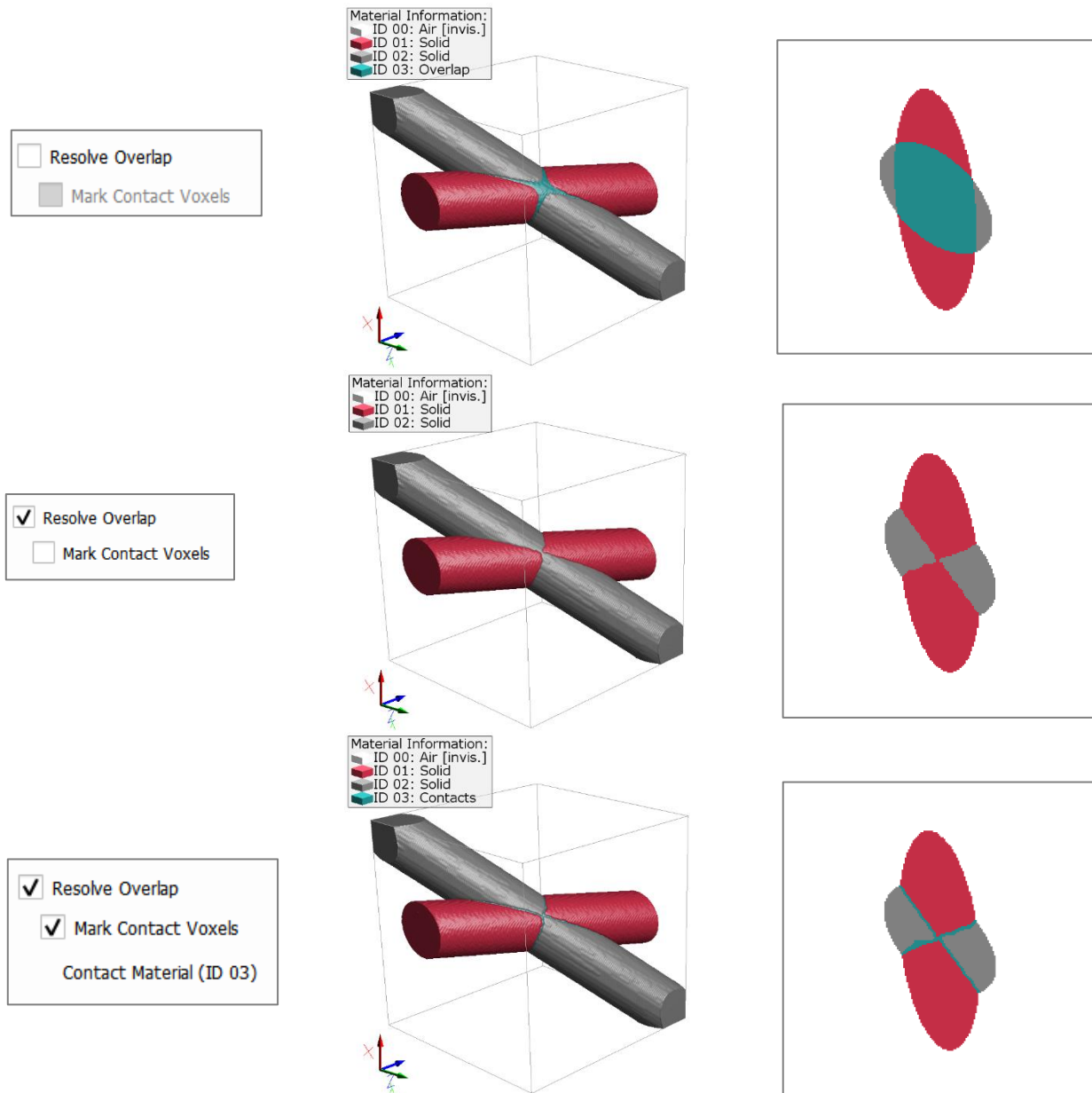

Default Overlap Material controls the material assigned to the regions where fibers of the newly generated structure overlap. The material ID of these regions is chosen by default as the next available material ID. The color settings and the constituent materials can be changed for each Material ID.



Overlap rules can be set to control how the overlap between materials should be handled in the structure about to be generated. The user can set rules by selecting a number in the box for **Number of Overlap Rules**, and then define these rules in the panel below.

The materials shown in the panel (as buttons or pull-down menu) correspond to the [Material](#) selected under the **Fiber Options** tab for the structure about to be generated.

In the example shown below, three rules have been defined: The **Overlap** of objects with **Material ID 1** (red) will be assigned to ID 3 (blue). The overlap of objects with material ID 2 (gray) will be assigned to ID 4 (orange) and the overlap of ID 1 and ID 2 will be assigned to ID 5 (magenta). For all other possible overlap cases, the **Default Overlap Material ID** is applied.

Number of Overlap Rules			3
	Material ID 1	Material ID 2	Overlap Material ID
1	01 Manual (Solid) ▾	01 Manual (Solid) ▾	03 Manual (Solid) ▾
2	02 Manual (Solid) ▾	02 Manual (Solid) ▾	04 Solid ▾
3	01 Manual (Solid) ▾	02 Manual (Solid) ▾	05 Solid ▾

Note, that the results for volume in the resulting report do not change for different overlap rules, as the values are computed before the post-processing is applied.

In the three examples given for **Resolve Overlap**, the **Absolute Object Distribution** is shown here:

Absolute object distribution:		
	Count	Volume / (%)
Total	realized: 2 target: 2 error: 0.00	realized: 11.09 target: --- error: ---
Object type 1	realized: 1 target: 1 error: 0.00	realized: 4.42 target: --- error: ---
Object type 2	realized: 1 target: 1 error: 0.00	realized: 6.68 target: --- error: ---

For the volume percentages of the final structure, refer to the **Statistics** tab above of the visualization area in GeoDict.

Here, the volume statistics are shown for the example with default overlap rules. The red fiber has 3.55 % of the volume, the grey fiber has 5.81 % and the overlap 1.73 %.

In the result file the overlap volume is proportionally added to the volume of the overlapping fibers.

Here, the red fiber obtains $3.55\% + (1.73/2)\% = 4.415\%$. Rounded, this results in the 4.42 % shown in the report.

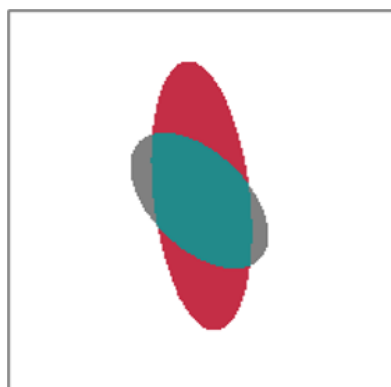

▶	C:/FiberGeo
▶	● Structure (200x200x200, 1 μm)
▶	● GAD Objects (2)
▼	📄 Statistics
▶	2D
▼	3D
	GAD Objects : 2
▼	Material IDs
	00 ID 00: 88.91 %
	01 ID 01: 3.55 %
	02 ID 02: 5.81 %
	03 ID 03: 1.73 %

RESULT OPTIONS

FiberGeo always saves the generated structure as a **GeoDict** structure file (*.gdt) (GeoDict structure binary). This file is placed in an automatically created result folder inside the chosen project folder (**File** → **Choose Project Folder...** in the menu bar). The result folder takes the name entered as **Result File Name (*.gdr)** at the top of the dialog.

An additional option to save the generated structure data is to check **Save Intermediate Result every** and enter a number of **Objects** in the box. As fibers are added to the fibrous structure during the generation, an intermediate result file is saved every time the number of placed objects reaches the entered value.

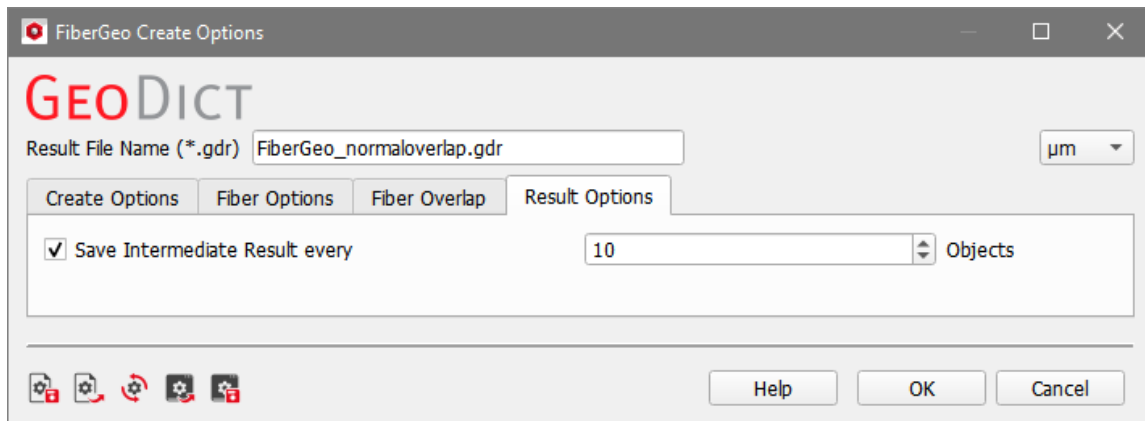

This option may be interesting when studying the properties of a series of increasingly dense fibrous structures.

After running the generation, the intermediate geometries can be found as *.gad analytic files in the result folder and can be loaded directly from the Result Viewer of the *.gdr result file.

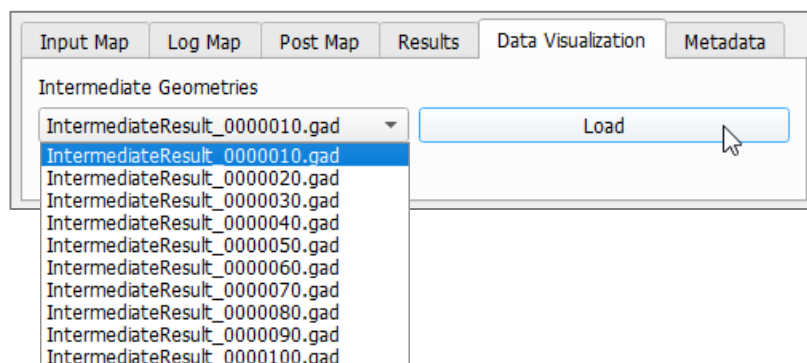

The parameters entered in the **FiberGeo Create Options** dialog can be saved into GPS (GeoDict Project Settings) files and/or loaded from them. Remember to restore and reset your (or **GeoDict's**) default values through the icons at the bottom of the dialog when needed and/or before every **FiberGeo** run.

Resting the mouse pointer over an icon prompts a ToolTip showing the icon's function to appear.



PILE FIBERS

With the selection of **Pile Fibers** from the **FiberGeo** section pull-down menu, fibers fall from their initial positions during the structure's generation and form a piled fibrous structure.

Clicking the pile **Options' Edit...** button opens the **FiberGeo Pile Options** dialog.

At the top left, the name for the files containing the generation results can be entered in the **Result File Name (*.gdr)** box. The default name can be kept, or a new name can be chosen fitting the current project.

The available units (**m**, **mm**, **µm**, **nm**, and **Voxel**) are selectable at the top right of the dialog. When the units are changed, the entered values are adjusted automatically.

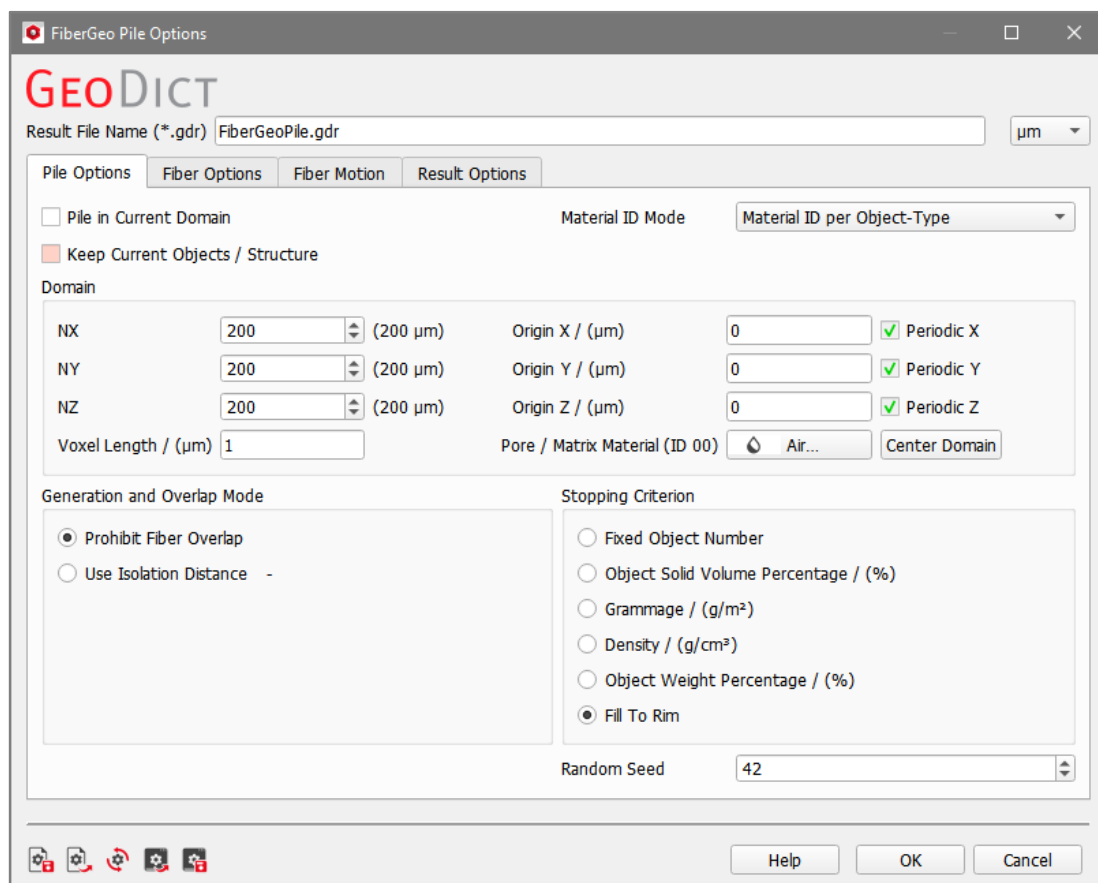
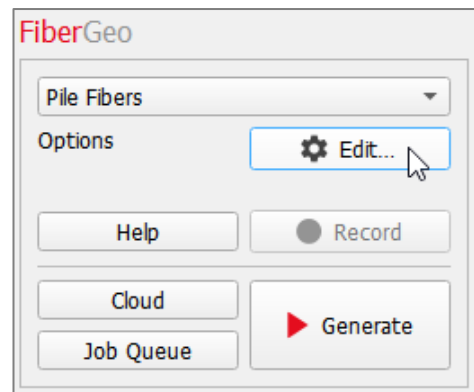

The options are organized through tabs.

- The **Pile Options** determine general properties of the resulting structure model such as size, resolution, and solid volume fraction.
- The **Fiber Options** define the geometrical properties of individual fiber types such as cross-section, length, and orientation. Up to 254 different object types can be used in one structure.
- The **Fiber Motion** controls the way the objects are piled. This is done by defining e.g. different step parameters and the initial object positions.
- The **Result Options** determine how the result files are saved.

PILE OPTIONS

The general parameters of the piled structure are entered through the selected **Pile Options** tab, and grouped into **Domain**, **Generation and Overlap Mode**, and **Stopping Criterion** panels.

The screenshot shows the 'Pile Options' tab in the FiberGeo software. It contains the following elements:

- Material ID Mode:** A dropdown menu set to 'Material ID per Object-Type'.
- Domain Section:**
 - Checkboxes: Pile in Current Domain, Keep Current Objects / Structure.
 - Input fields: NX (200), NY (200), NZ (200), Voxel Length / (μm) (1).
 - Origin fields: Origin X / (μm) (0), Origin Y / (μm) (0), Origin Z / (μm) (0).
 - Periodicity: Periodic X, Periodic Y, Periodic Z.
 - Buttons: Pore / Matrix Material (ID 00) with a dropdown set to 'Air...', and 'Center Domain'.
- Generation and Overlap Mode Section:**
 - Radio buttons: Prohibit Fiber Overlap, Use Isolation Distance.
- Stopping Criterion Section:**
 - Radio buttons: Fixed Object Number, Object Solid Volume Percentage / (%), Grammage / (g/m²), Density / (g/cm³), Object Weight Percentage / (%), Fill To Rim.
- Random Seed:** A field set to 42.

PILE IN CURRENT DOMAIN AND KEEP CURRENT OBJECTS / STRUCTURE

When checking **Pile in Current Domain**, the structure currently in memory, is used in combination with the newly piled fibrous structure.

Observe the effect that checking, or leaving un-checked, the **Pile in Current Domain** and the **Keep Objects/ Structure** boxes have on the generation of a fibrous structure.

A (grey) structure is already in memory and the red fibers fall from the Z+ direction.

When **Pile in Current Domain** is chosen, the new elements (red) fall on the structure already in memory (grey).

With the **Keep Current Objects / Structure** Checkbox, the user can decide if the grey structure is kept or deleted after piling.

When **Pile in Current Domain** is not checked, the grey structure is not considered at all.

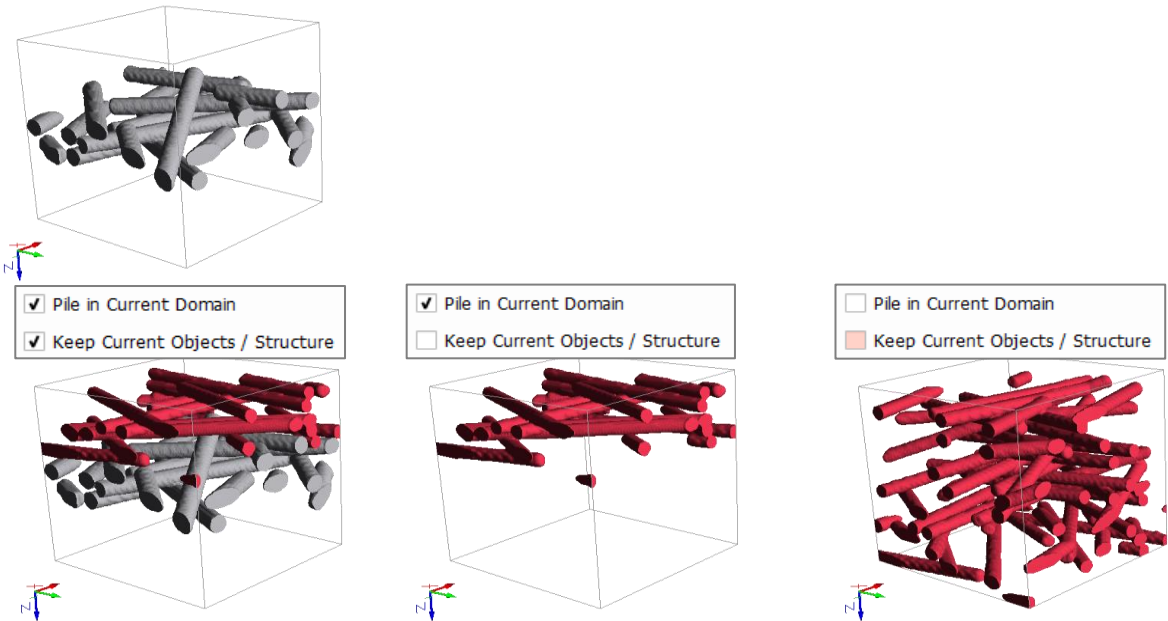

Note that the domain parameters, grouped under the **Domain** panel, cannot be modified when the **Pile in Current Structure** box is checked, because they are kept from the structure already in memory.

DOMAIN PARAMETERS

The **Domain** panel contains the parameters defining the structure size (**NX**, **NY**, and **NZ**) in combination with the resolution (**Voxel Length**), as well as the **Origin** parameters, the **Periodicity** checkboxes, the **Center Domain** button, and the **Pore/ Matrix Material** pull-down menu. The periodicity boxes are disabled (and checked) for **Pile**, because the objects are always piled periodically.

Domain					
NX	200	(200 μm)	Origin X / (μm)	0	<input checked="" type="checkbox"/> Periodic X
NY	200	(200 μm)	Origin Y / (μm)	0	<input checked="" type="checkbox"/> Periodic Y
NZ	200	(200 μm)	Origin Z / (μm)	0	<input checked="" type="checkbox"/> Periodic Z
Voxel Length / (μm)	1		Pore / Matrix Material (ID 00)	Air...	Center Domain

NX, NY, NZ, and Voxel Length

The internal representation of a structure in **GeoDict** consists of rectangular 3D arrays of equally sized boxes, hereafter called volume elements or **voxels**. **NX**, **NY**, and **NZ** are the number (N) of voxels in X, Y and Z directions.

The **Voxel Length** is the size of one voxel in the chosen units. Varying the values for **NX**, **NY**, and **NZ** changes the size of the piled structure in the given direction.

NX	<input type="text" value="200"/>	<input type="button" value="↓"/>	<input type="button" value="↑"/>	(200 μm)
NY	<input type="text" value="200"/>	<input type="button" value="↓"/>	<input type="button" value="↑"/>	(200 μm)
NZ	<input type="text" value="200"/>	<input type="button" value="↓"/>	<input type="button" value="↑"/>	(200 μm)
Voxel Length / (μm)	<input type="text" value="1"/>			

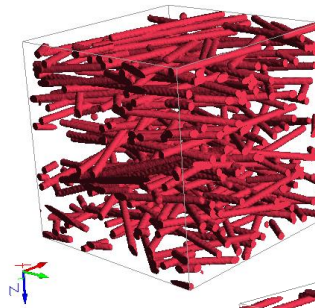

NX	<input type="text" value="300"/>	<input type="button" value="↓"/>	<input type="button" value="↑"/>	(300 μm)
NY	<input type="text" value="200"/>	<input type="button" value="↓"/>	<input type="button" value="↑"/>	(200 μm)
NZ	<input type="text" value="200"/>	<input type="button" value="↓"/>	<input type="button" value="↑"/>	(200 μm)
Voxel Length / (μm)	<input type="text" value="1"/>			

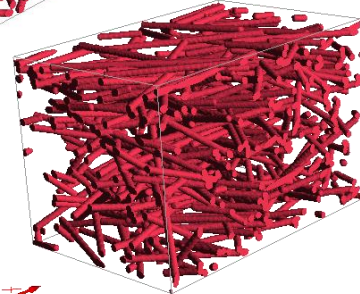

NX	<input type="text" value="200"/>	<input type="button" value="↓"/>	<input type="button" value="↑"/>	(200 μm)
NY	<input type="text" value="300"/>	<input type="button" value="↓"/>	<input type="button" value="↑"/>	(300 μm)
NZ	<input type="text" value="200"/>	<input type="button" value="↓"/>	<input type="button" value="↑"/>	(200 μm)
Voxel Length / (μm)	<input type="text" value="1"/>			

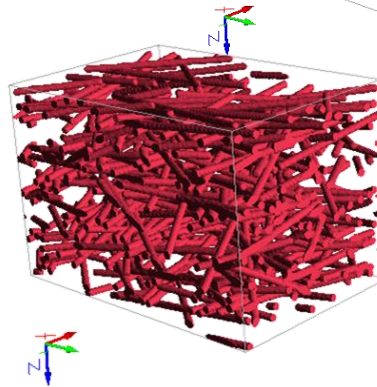

Low values for voxel length result in higher resolution, but also in higher computational time. After setting the values of **NX**, **NY**, **NZ** and **Voxel Length**, the physical structure size is automatically displayed in the chosen units.

Observe how keeping the structure size at a constant $100 \times 100 \times 100 \mu\text{m}^3$ while decreasing the Voxel Length from $0.5 \mu\text{m}$ to $0.25 \mu\text{m}$ has the effect of refining the fibers in the pile by increasing the resolution. Since the voxel length has decreased to half, the size of the structure is kept by doubling the **NX**, **NY**, and **NZ** values from 200 to 400.

NX	<input type="text" value="200"/>	<input type="button" value="↓"/>	<input type="button" value="↑"/>	(100 μm)
NY	<input type="text" value="200"/>	<input type="button" value="↓"/>	<input type="button" value="↑"/>	(100 μm)
NZ	<input type="text" value="200"/>	<input type="button" value="↓"/>	<input type="button" value="↑"/>	(100 μm)
Voxel Length / (μm)	<input type="text" value="0.5"/>			

NX	<input type="text" value="400"/>	<input type="button" value="↓"/>	<input type="button" value="↑"/>	(200 μm)
NY	<input type="text" value="400"/>	<input type="button" value="↓"/>	<input type="button" value="↑"/>	(200 μm)
NZ	<input type="text" value="400"/>	<input type="button" value="↓"/>	<input type="button" value="↑"/>	(200 μm)
Voxel Length / (μm)	<input type="text" value="0.5"/>			

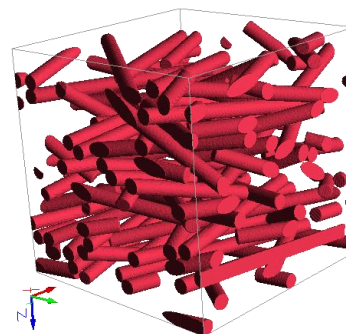
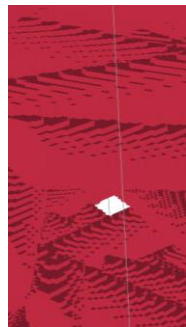
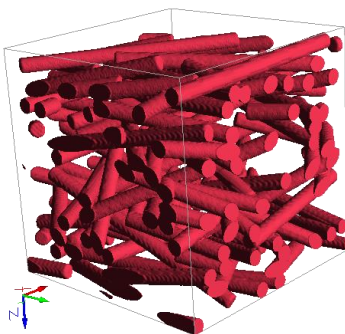

Origin x, Origin y, and Origin z, and Center Domain

The **Origin X**, **Origin Y**, and **Origin Z** parameters, together with the **Center Domain** button, determine the placement of the piled structure in the domain in the same way as seen for **FiberGeo – Create** (pages [8ff.](#)).

GENERATION AND OVERLAP MODE

The options in the **Generation and Overlap Mode** panel control the relative position among the fibers in the pile (or with the objects of the structure currently in memory).

Fibers may touch (but not overlap) when **Prohibit Fiber Overlap** is selected. Fibers may not touch when **Use Isolation Distance** is selected, and a positive value is entered. Then, the gaps between fibers have at least this preset voxel distance. The choice of **Use Isolation Distance** may lead to long computation times when using a high resolution in big structures.

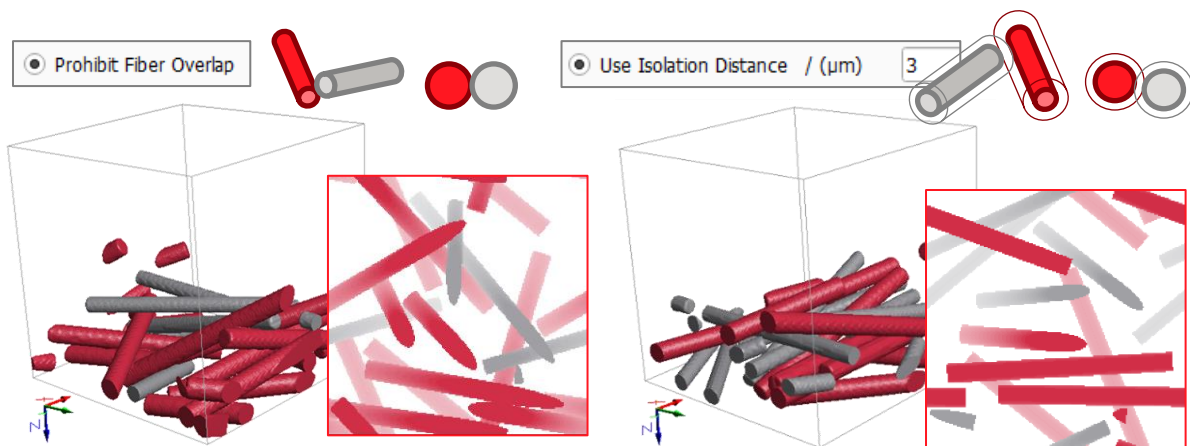

STOPPING CRITERION

The parameters in the **Stopping Criterion** panel control whether the pile process should be continued, or the material is “ready”. The analysis of the results file (GDT file) shows any disparity between achieved result values and desired ones.

Besides the same options available for **FiberGeo – Create** (pages [23ff.](#)), it is also possible to choose **Fill to Rim**.

Stopping Criterion

- Fixed Object Number
- Object Solid Volume Percentage / (%)
- Grammage / (g/m²)
- Density / (g/cm³)
- Object Weight Percentage / (%)
- Fill To Rim

Fill to rim

Fill to Rim forces the fibers to keep piling until they reach the top of the bounding box in the Z-direction.

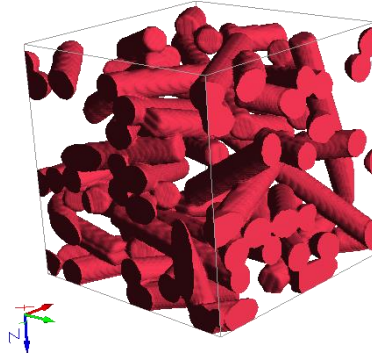

RANDOM SEED

Random Seed initializes the random number generator behind the structure generator. Changing its value produces different sequences of random numbers and hence, different realizations of the specified structure. If all settings are equal, generating with the same **Random Seed** value produces exactly the same structure. **Random Seed** is a non-negative integer number.

Varying the **Random Seed** allows generating different samples of the same piled fibrous structure. In the following examples, all parameters are unchanged while the Random Seed changes with every generation run (e.g. 6, 15, 22).

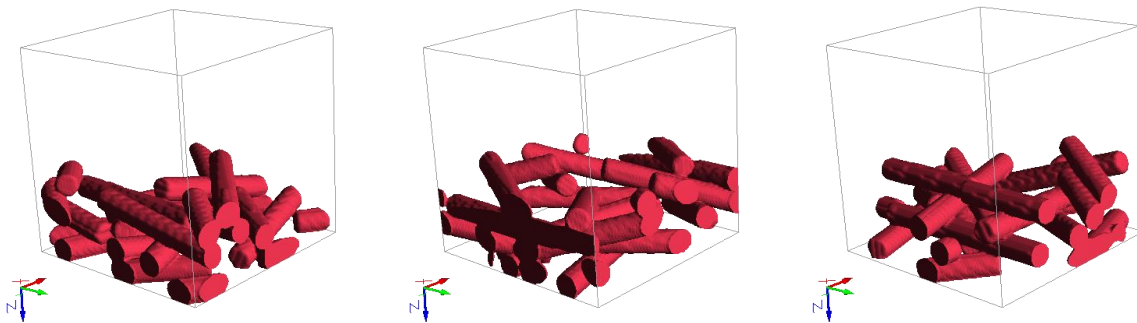

FIBER OPTIONS

The objects available to pile fibrous structures (**Pile**) are organized and listed in panels in a way close to the one for creating fibrous structures (**Create**). Up to 254 different fiber types can be added to the same structure.

The object list is limited to **Short** fibers and **Curved Circular** fibers. See the detailed explanations above, starting on page 31. The center position of the objects is a result of the piling process and cannot be specified.

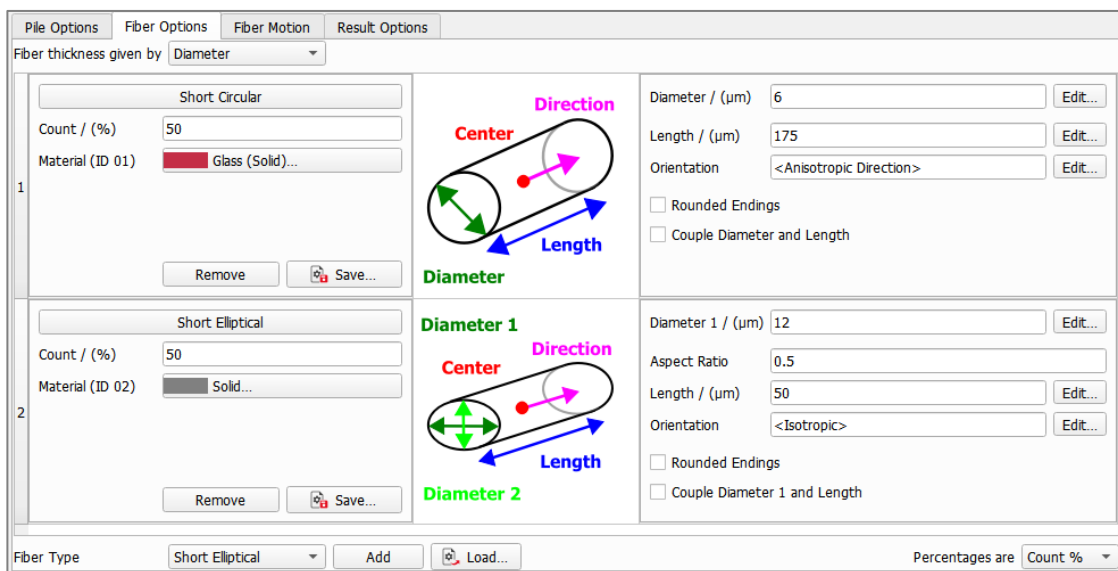

FIBER MOTION

The **Fiber Motion** parameters control the object's movement and initial position during the piling process, and are grouped into the **Piling Step**, and the **Object Position** panels. The **Pile Mode** can be selected from the pull-down menu.

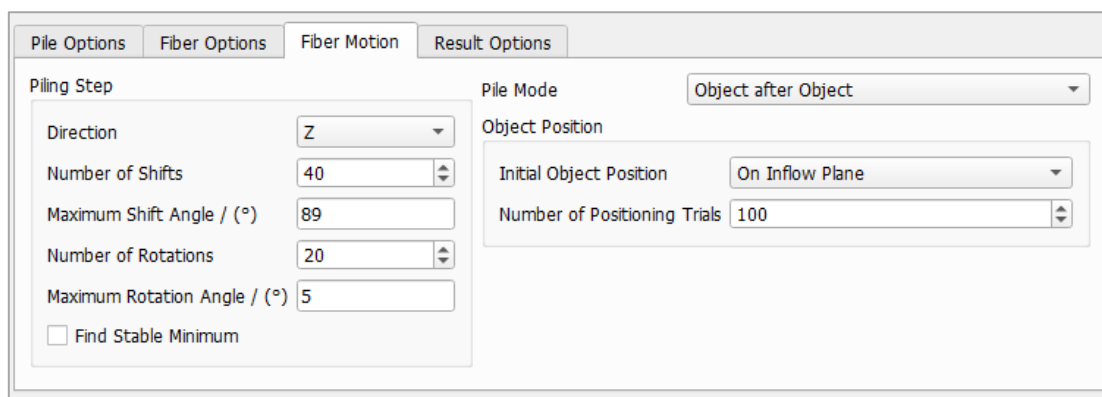

PILING STEP

The object movements during the piling steps are mainly defined by the falling **Direction** and by the automatic finding of the stable minimum (**Find Stable Minimum**).

When the result is unsatisfactory, additional parameters can be used to refine it (**Number of Shifts**, **Maximum Shift Angle**, **Number of Rotations** per shift and **Maximum Rotation Angle**).

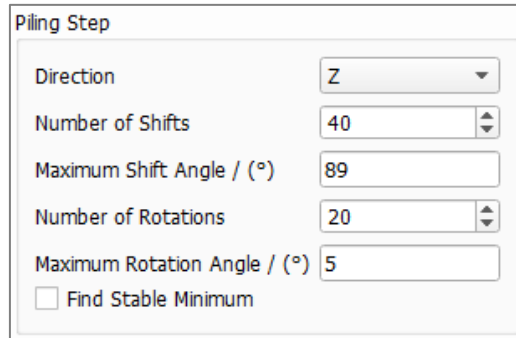

The option to find the stable minimum is not available when all objects fall at the same time (**Pile Mode** → **All Objects at Once**).

Direction

The **Direction** in which the piling process happens can be chosen from the pull-down menu. For all three axes, the objects fall towards the positive direction (X+, Y+, or Z+). Observe the piling of fibers with **On Inflow Plane Center** as initial object position, falling from all three directions.

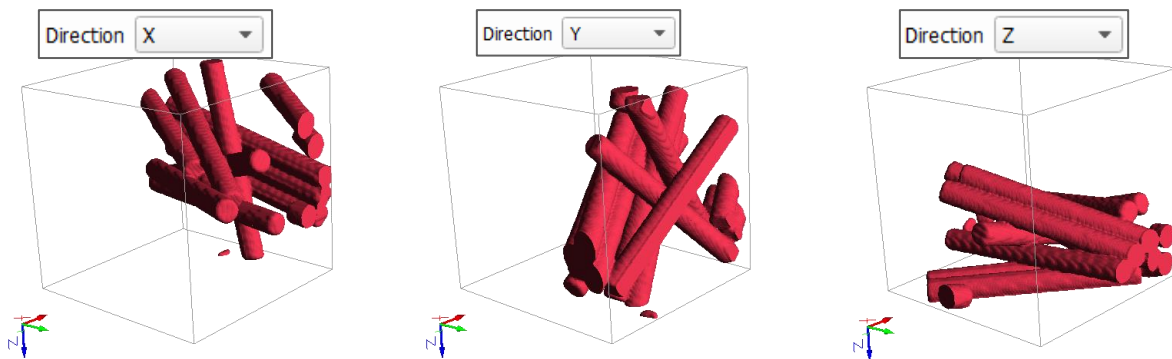

Number of Shifts, Maximum Shift Angle, Number of Rotations, Maximum Rotation Angle

Throughout the piling process, the objects fall and roll to their final location in the fibrous structure. After the fall, i.e. after hitting an obstacle as the bottom domain boundary or another object, the fibers shift and rotate as many times as defined by the values for **Number of Shifts** and **Number of Rotations** before they come to rest at the bottom of the structure. Low values for shifts and rotations produce structures with fibers that settle earlier compared to larger values of these parameters, resulting in a lower packing density.

In detail, the algorithm for each shift tries the given number of rotations. If a better position is found for the fiber, lower in the specified direction and without overlapping with other fibers, it is used as a new point for the object. Then, the numbers of shift and rotation are reset. The algorithm terminates if no new position is found for the given number of shifts and rotations.

Observe the effect of setting a low or a high **Number of Shifts** value on the final position of fibers in the same piled structure.

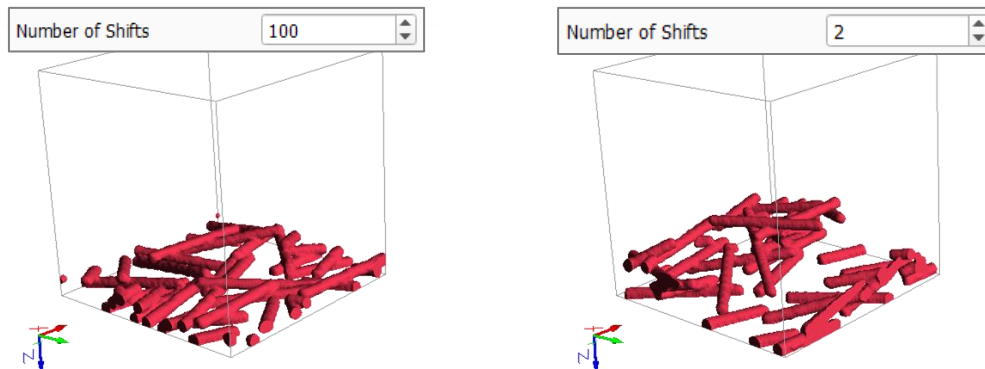

Find Stable Minimum

When checking **Find Stable Minimum**, each fiber is checked to have a stable state with respect to gravity at the end of the piling process.

Observe the effect of checking or un-checking **Find Stable Minimum** in the piling of 100 fibers with initial object position **On Inflow Plane Center**.

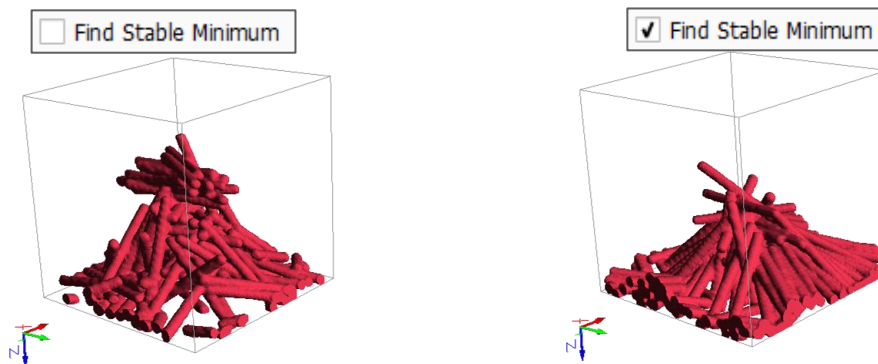

While it is faster to pile structures with an un-checked **Find Stable Minimum** box, the resulting packing densities are lower.

Observe the realized **Volume / (%)** value (shown in the result file under the Results tab) when **Find Stable Minimum** is checked or un-checked. The piled structures of fibers with initial object position **On Inflow Plane**, and **Fill To Rim** as stopping criterion, look fairly similar but the realized volume percentages are rather different.

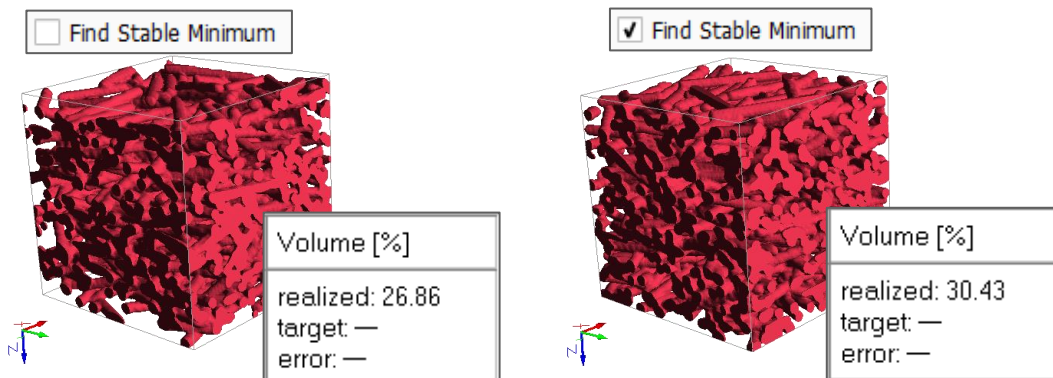

PILE MODE AND OBJECT POSITIONS

Select from the pull-down menu whether the objects should fall one after another (**Object after Object**) or all should fall at once (**All Objects at Once**).

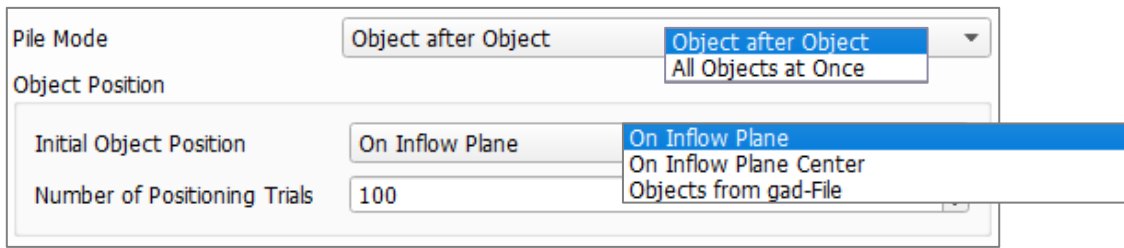

When choosing **Object after Object**, the pull-down menu allows setting the initial position from which the piling objects are set to fall: the whole initial position plane (**On Inflow Plane**), from its center (**On Inflow Plane Center**), or to originate from an existing structure (**Objects from gad File**).

When piling objects **On Inflow Plane** or **On Inflow Plane Center**, the **Number of Positioning Trials** can be adjusted at the cost of additional runtime to increase the quality of the piled structure.

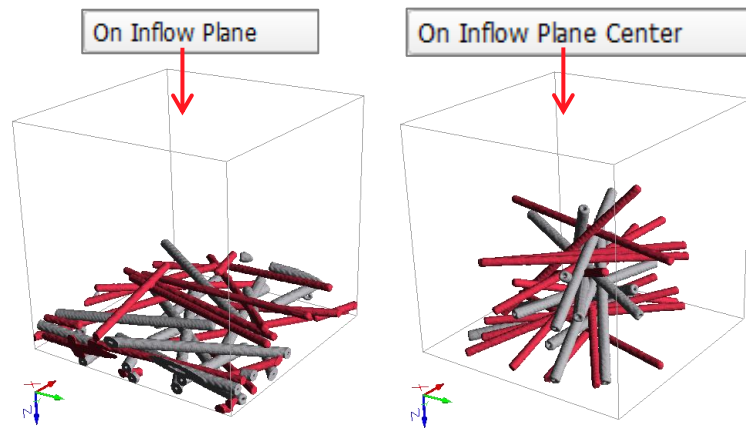

When piling from an existing GAD structure, the objects are those already in the structure and no objects (and their geometry parameters) need to be selected through the **Fiber Options** tab. Clicking **Browse**, a structure saved in GAD format can be selected as the origin of the objects.

When choosing **All Objects at Once**, the objects can only originate from the analytic data of an existing structure.

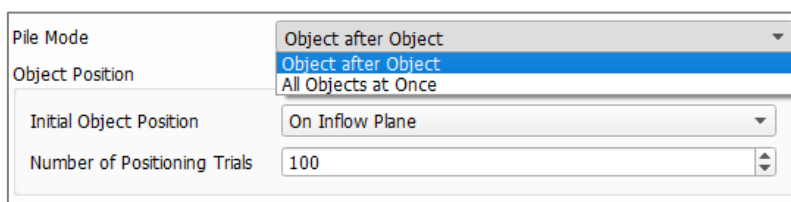

Structures in GAD format to be used for piling must conform to certain requirements (no overlapping, periodicity, no objects crossing bottom plate) and should be generated for later piling with these requirements in mind. Overlap can be removed after generation using **GadGeo** → **Remove Object Overlap**.

Assuming the Z-direction to be the piling direction, and downwards to be the positive direction (Z+), the following situations have to be considered:

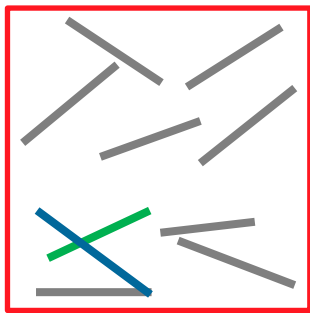

Touching, but not overlapping, is allowed for piling. The initial structure must be generated without overlapping. For example, by selecting **Remove Overlap** when generating with **FiberGeo** → **Create** (or other **GeoDict** generators).

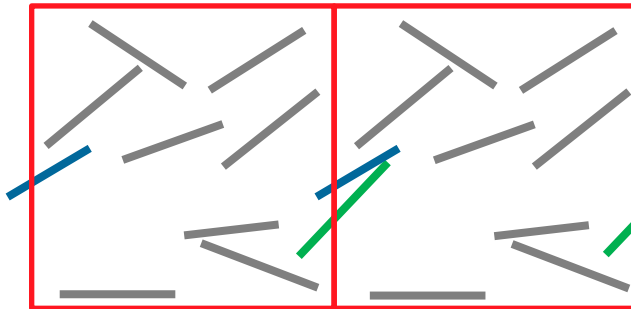

Periodicity is needed in the X and Y directions for piling, to avoid undesired intersections at the edge of the structure. The initial GAD file must be generated to be periodic (in all directions).

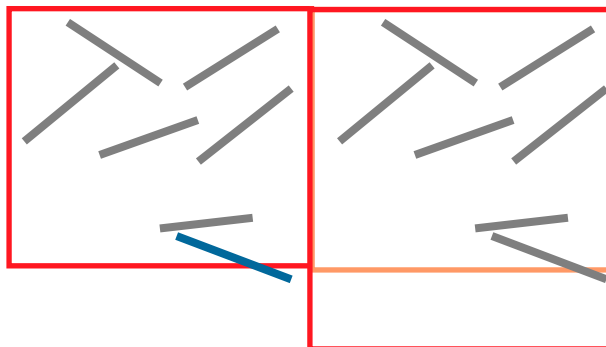

No objects are allowed to drop off the bottom of the structure. When this happens, the dimensions of the initial *gad file must be processed to include the extruding object.

This can be done by adding enough empty voxels in Z+ direction by **Model** → **ProcessGeo** → **Embed** and checking Embed Analytic Objects.

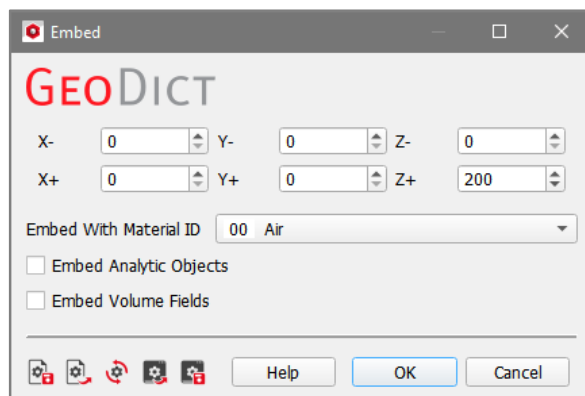
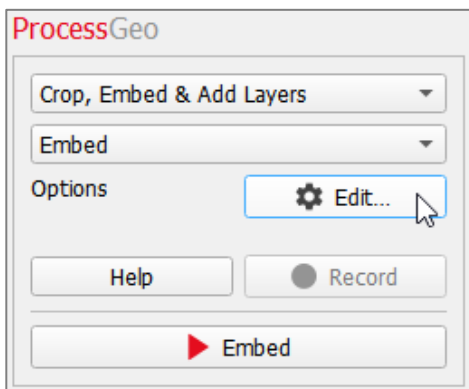

Or by increasing the size of the domain in Z-direction **Model** → **GadGeo** → **Edit Domain**.

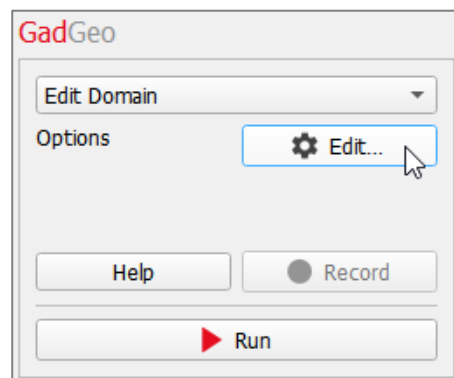

The number of voxels to be added depends on how far objects overlap the original domain in Z-direction.

Before piling, the domain size in Z-direction under the **Pile Options** tab – **Domain** panel must be increased to adjust to the larger one of the modified GAD file.

For example:

NX	200	(200 μm)
NY	200	(200 μm)
NZ	200	(200 μm)
Voxel Length / (μm)	1	

→

NX	200	(200 μm)
NY	200	(200 μm)
NZ	400	(400 μm)
Voxel Length / (μm)	1	

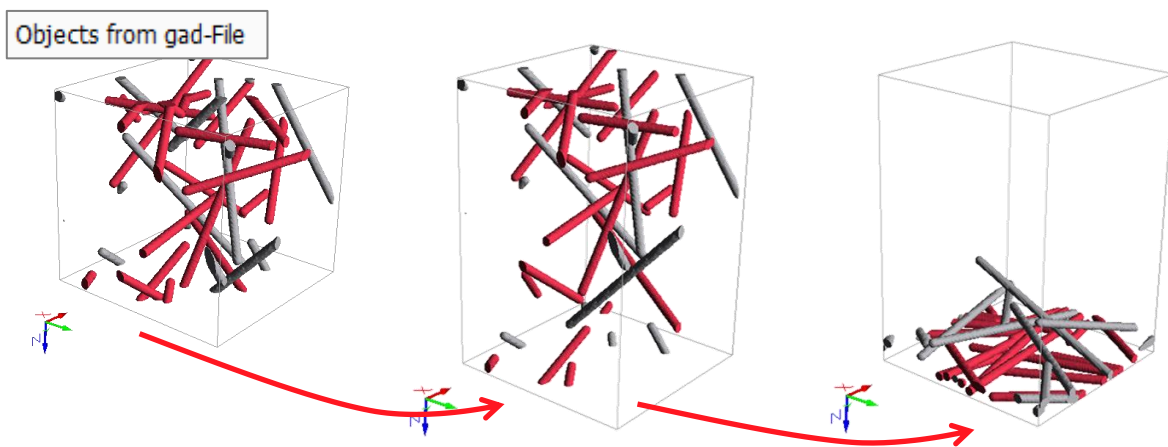

Before the piling process starts from a structure in GAD-format, the position of the objects it contains can be slightly changed by two Parameters.

The distance between the objects in the piling direction can be enlarged by the factor entered in **Loosen Objects**.

Additionally, all objects can be lifted by the distance entered in **Lift Objects**. For example, these parameters can be used to generate structures similar to those from sieving processes combined with additional shaking.

RESULT OPTIONS

The pile **Result Options** on managing the saving of result and geometry files are completely analogous to the **Create Result Options** explained on (pages [82ff.](#)).

DISTRIBUTE

When **Distribute** is selected from the pull-down menu in the **FiberGeo** section, the fibers are uniformly spread throughout the structure. Only structures that contain analytic information (GAD objects) can be used for the distribution of objects.

To use this feature, the domain must be periodic, and the objects are not allowed to overlap. **Distribute** allows to create a homogeneous structure even for structures created with **Pile** where boundary effects occur in the lay-down direction.

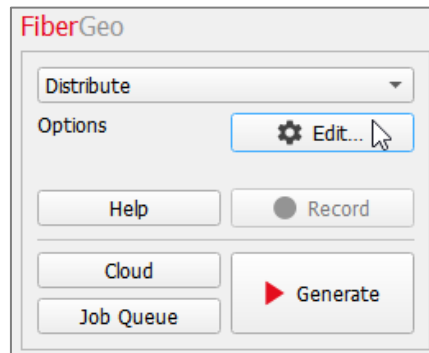

Clicking the **Options' Edit...** button opens the **Distribute Options** dialog.

When the desired parameters have been entered in the **Distribute Options** dialog, clicking **OK** closes the dialog and returns to the **FiberGeo** section.

Clicking **Generate** starts the distribution process.

The result of the distribution process can be saved under **File** → **Save Structure as** in the menu bar.

A fibrous structure containing GAD information has to be in memory.

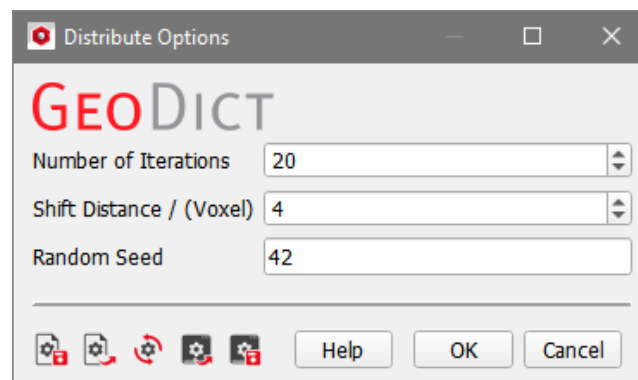

Without a structure in memory, clicking **Generate** results in an error message.

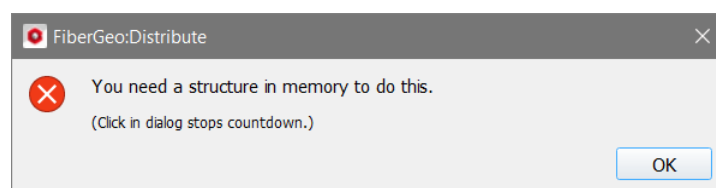

When the structure in the selected file is not periodic, an information message appears indicating that periodicity will be applied in all three directions and the loaded structure will be treated as periodic. The GAD objects are still distributed.

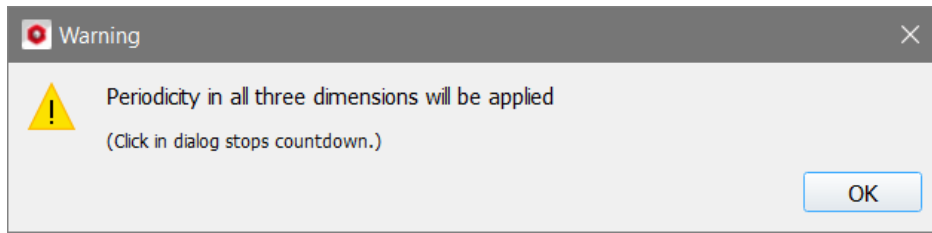

If the loaded structure contains overlap the distribution is not executed and an error message appears.

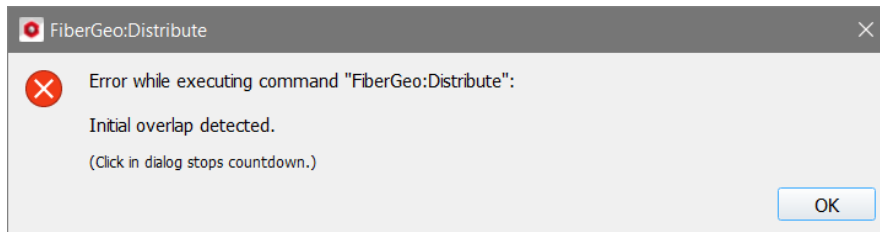

In the **Distribute Options** dialog, **Number of Iterations**, **Shift Distance**, and **Random Seed** specify the distribution process.

Observe the process of distributing the short circular fibers in a 200 x 200 x 200 structure, periodic in all directions, generated with **FiberGeo Create** with a Voxel Length of 1 μm . The fiber centers follow a density distribution, which results in a layered structure. The following values are used for the distribution process: **Number of Iterations** are 50, **Shift Distance** is 4 voxels, **Random Seed** is 1.

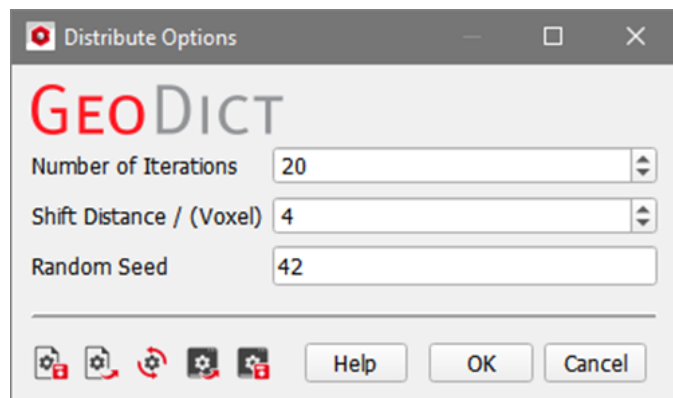
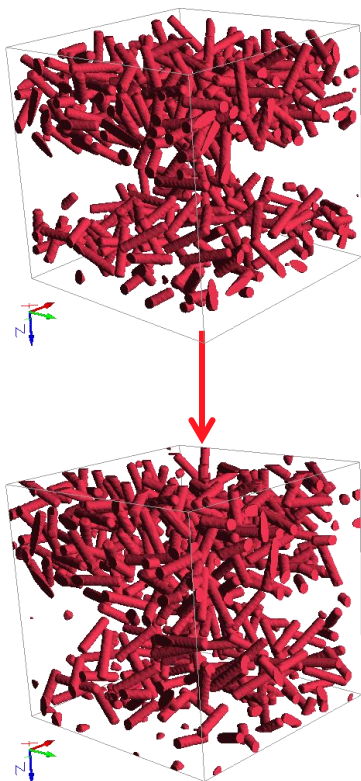

The **Number of Iterations** determines how many distribution steps are done. More distribution steps lead to a wider distribution of the objects, which is getting closer to a uniform distribution.

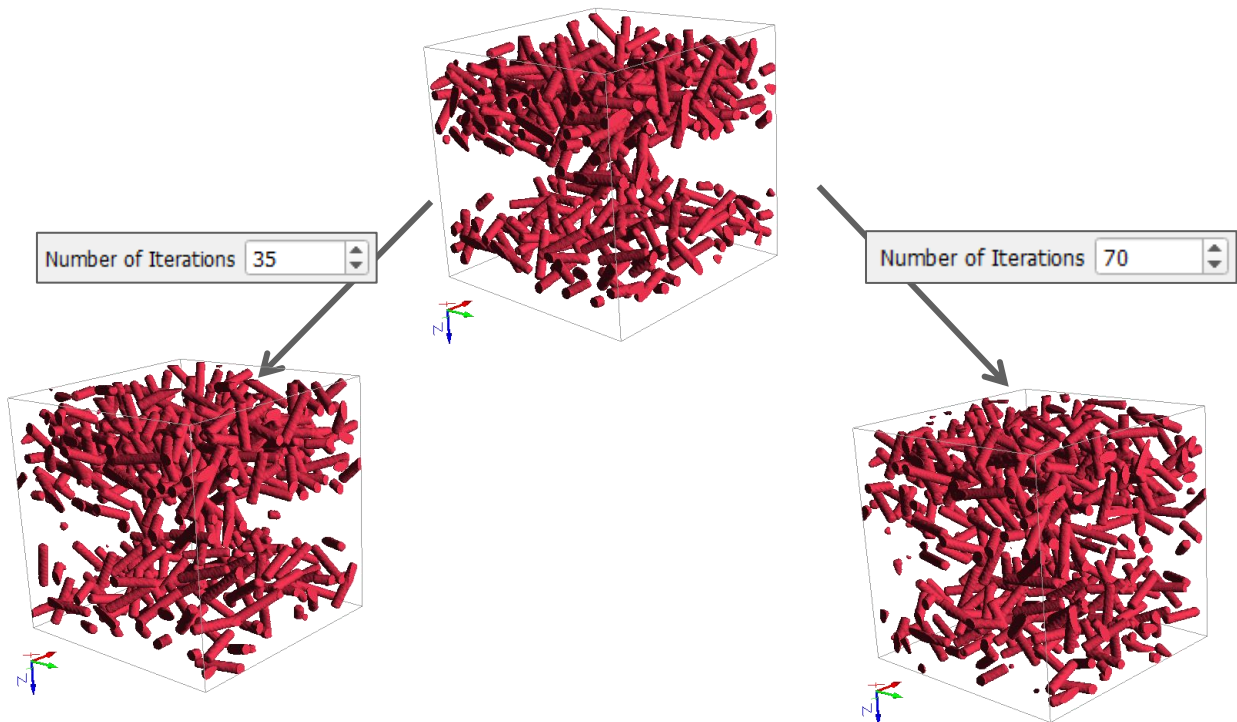

The **Shift Distance** determines the maximal object movement during a single iteration. Large shift distances lead to more computational time per iteration. Observe the effect of increasing the shift distance from 1 to 4 and then to 10, while the number of iterations is kept at 35.

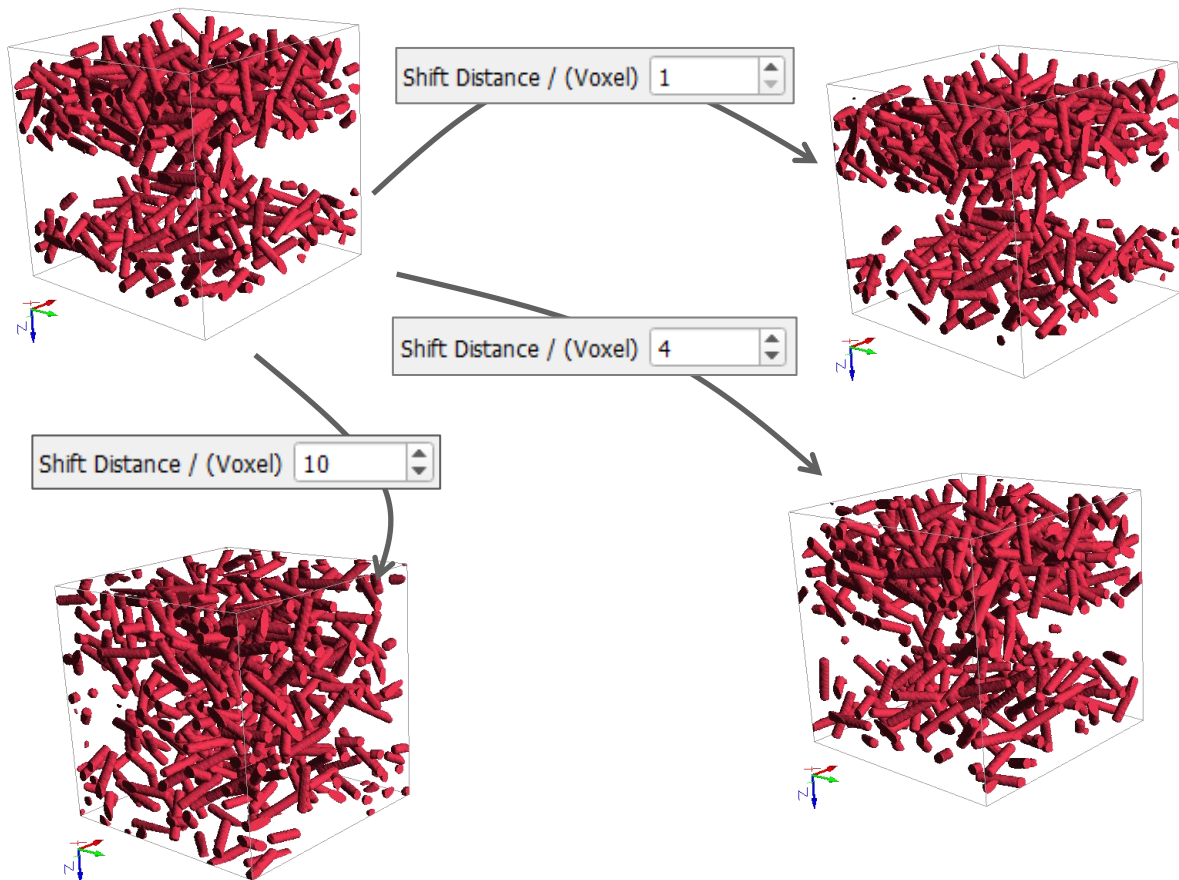

ADD BINDER

To generate realistic models of nonwoven fibrous structures (for example for the technical textile industry), the correct addition of binder is essential. It is used to provide structural integrity by bonding the fibers.

Add Binder to a structure consists of adding material in the shape of a concave meniscus in locations where surfaces in that structure's material are close together.

For hollow fibers, such as Short Hollow, Short Cellulose, Infinite Hollow, Infinite Cellulose, Curved Hollow, and Curved Cellulose, but also for hollow objects such as hollow spheres the algorithm under **Add Binder** needs analytic object data (GAD file) to discern that the empty voxels inside these objects are not part of the pore space. Without analytic data, i.e. when using voxel models, binder is also added inside the hollow objects, which might be inaccurate.

Clicking the **Options' Edit...** button opens the **Add Binder** dialog. Clicking **OK** in it closes the dialog and returns to the **FiberGeo** section. Clicking **Generate** starts the process.

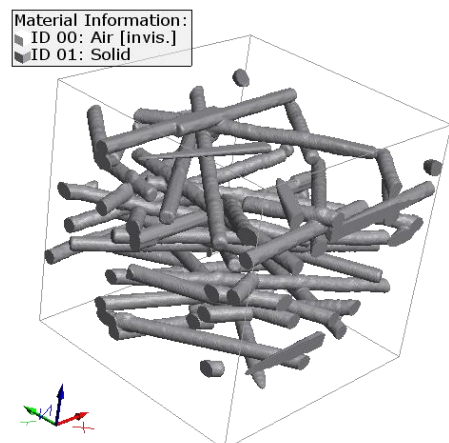
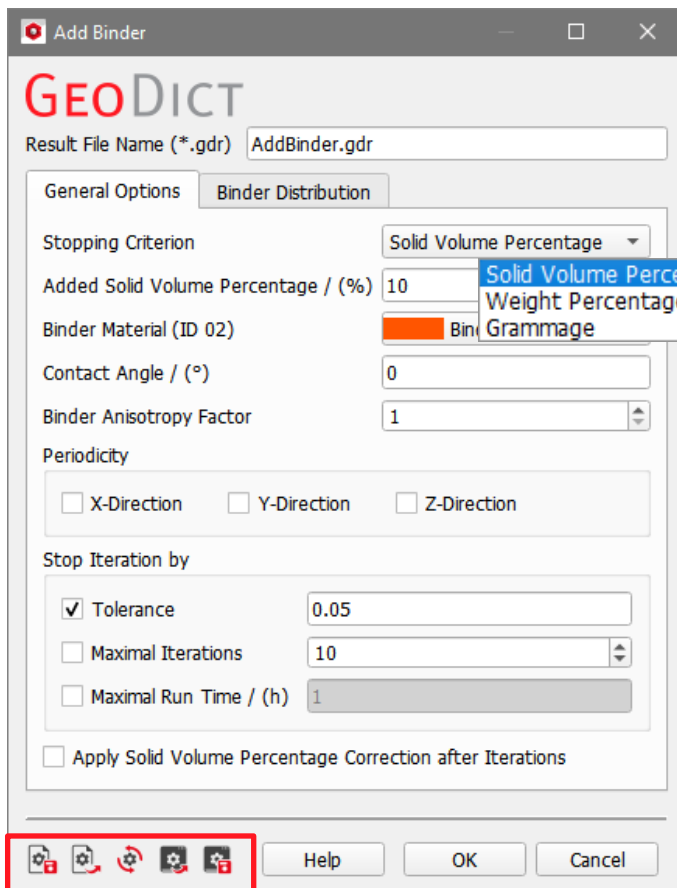
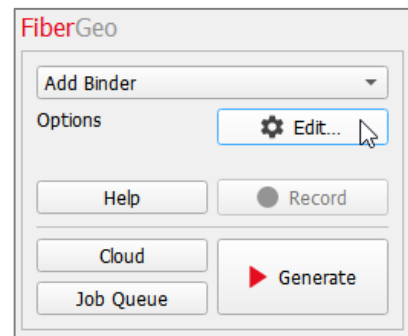

At the top of the **Add Binder** dialog, the name for the file containing the results of adding binding can be entered in the **Result File Name (*.gdr)** box. The default name can be kept, or a new name can be chosen, fitting the current project.

GENERAL OPTIONS

STOPPING CRITERION

The user may choose the most appropriate stopping criterion when adding binder. The chosen **Stopping Criterion** interrupts the addition of binder when it is reached. The available stopping criteria are **Solid Volume Percentage**, **Weight Percentage**, and **Grammage**.

Solid Volume Percentage

The binder volume reaches a pre-established **Added Solid Volume Percentage (%)** relative to the total volume. The added material is displayed as a volume amount deposited on the structure.

The **Binder Material** is assigned to the next available material ID, and the appropriate material to be used as binder should be selected from the material database by clicking the button.

The screenshot shows the 'Binder Distribution' settings panel. The 'Stopping Criterion' is set to 'Solid Volume Percentage'. The 'Added Solid Volume Percentage / (%)' is set to 10. The 'Binder Material (ID 02)' is set to 'Manual (Solid) ...'. The 'Contact Angle / (°)' is set to 0. The 'Binder Anisotropy Factor' is set to 1.

Weight Percentage

The weight of binder reaches a certain percentage of the weight of material.

As seen above for the Solid Volume Percentage stopping criterion, the **Binder Material** is assigned to the next available material ID, and the appropriate **Binder Material** should be selected from the material database by clicking the button.

It is necessary to set the density for the structure's material (**Material Density**) and for the binder material (**Binder Density**) both in g/cm^3 , as well as the desired (weight) percentage of binder material to structure material (**Binder Weight Percentage**, in %). That is, a **Binder weight percentage** of 20 means that there are 20 g of binder added per 100 g of objects in the structure.

The screenshot shows the 'Binder Distribution' settings panel. The 'Stopping Criterion' is set to 'Weight Percentage'. The 'Binder Weight Percentage / (%)' is set to 20. The 'Binder Material (ID 02)' is set to 'Manual (Solid) ...'. The 'Material Density / (g/cm³)' is set to 1. The 'Binder Density / (g/cm³)' is set to 2.7. The 'Contact Angle / (°)' is set to 0. The 'Binder Anisotropy Factor' is set to 1.

For example, two types of binder (with high density, e.g. Manual 5 g/cm^3 and with lower density, e.g. Polypropylene, 0.9 g/cm^3) are added to a fibrous material with a

density of 1 g/cm³. Setting a **Binder weight percentage** of 20% (20 g binder/100 g objects), the amount of binder material deposited is much larger when the binder is less dense.

Stopping Criterion	Weight Percentage
Binder Weight Percentage / (%)	20
Binder Material (ID 02)	Manual (Solid) ...
Material Density / (g/cm ³)	1
Binder Density / (g/cm ³)	5
Contact Angle / (°)	0
Binder Anisotropy Factor	1

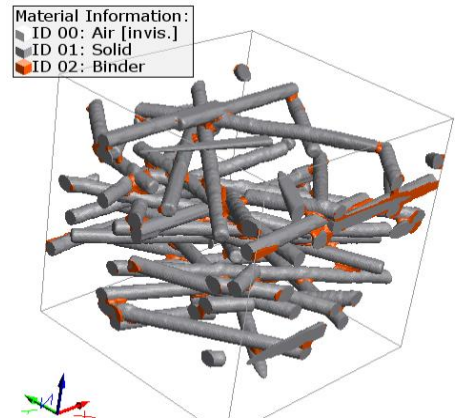

Stopping Criterion	Weight Percentage
Binder Weight Percentage / (%)	20
Binder Material (ID 02)	Manual (Solid) ...
Material Density / (g/cm ³)	1
Binder Density / (g/cm ³)	0.9
Contact Angle / (°)	0
Binder Anisotropy Factor	1

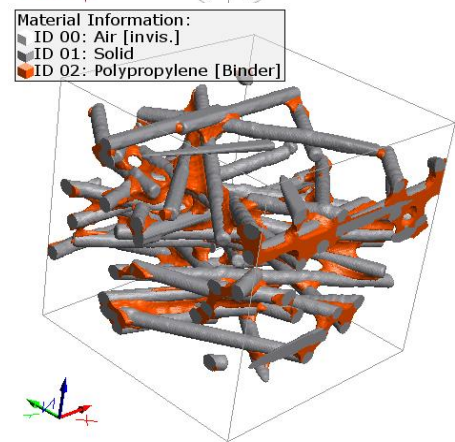

For Weight Percentage, when **Manual** or **Undefined** are selected, the user must enter the density of the binder (**Binder Density [g/cm³]**). If a material is selected from the database, the **Binder Density** (in g/cm³) of the binder material is automatically entered. If a manual material is used frequently, it is useful to save it to the material database.

Grammage

Reaching the **Added Grammage** (material and binder, g/m²) stops the addition of binder.

As seen above for the Solid Volume Percentage stopping criterion, the **Binder Material** is assigned to the next available material ID and the appropriate material to be used as binder is selected from the material database by clicking the button.

General Options		Binder Distribution
Stopping Criterion	Grammage	
Added Grammage / (g/m ²)	10	
Binder Material (ID 02)	Manual (Solid) ...	
Binder Density / (g/cm ³)	2.7	
Contact Angle / (°)	0	
Binder Anisotropy Factor	1	

For **Grammage**, when **Manual** or **Undefined** are selected, the density of the binder is not automatically taken from the database and the user must enter it manually (**Binder Density / (g/cm³)**). If a manual material is used frequently, it is useful to save it to the material database.

CONTACT ANGLE

The **Contact Angle** defines the angle in which the binder is deposited in relation to the materials in the structure. Values between 0° and 60° are accepted.

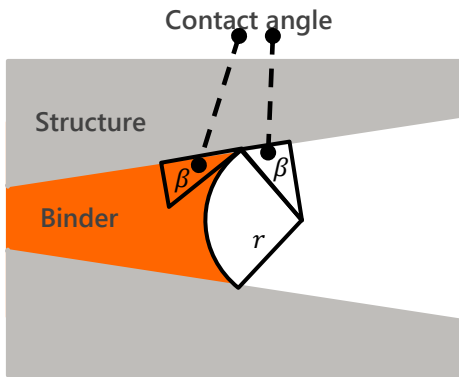

The contact angle helps to optimize and realistically model the addition of binder.

Observe the effect of adding binder with a **Contact Angle** of 0° or 45°.

Stopping Criterion	Solid Volume Percentage ▾
Added Solid Volume Percentage / (%)	5
Binder Material (ID 02)	■ Manual (Solid) ...
Contact Angle / (°)	0
Binder Anisotropy Factor	1

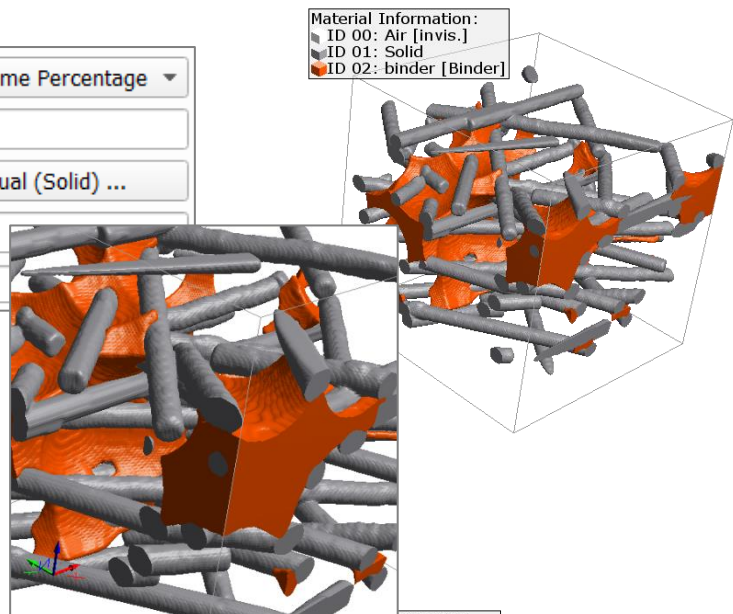

Stopping Criterion	Solid Volume Percentage ▾
Added Solid Volume Percentage / (%)	5
Binder Material (ID 02)	■ Manual (Solid) ...
Contact Angle / (°)	45
Binder Anisotropy Factor	1

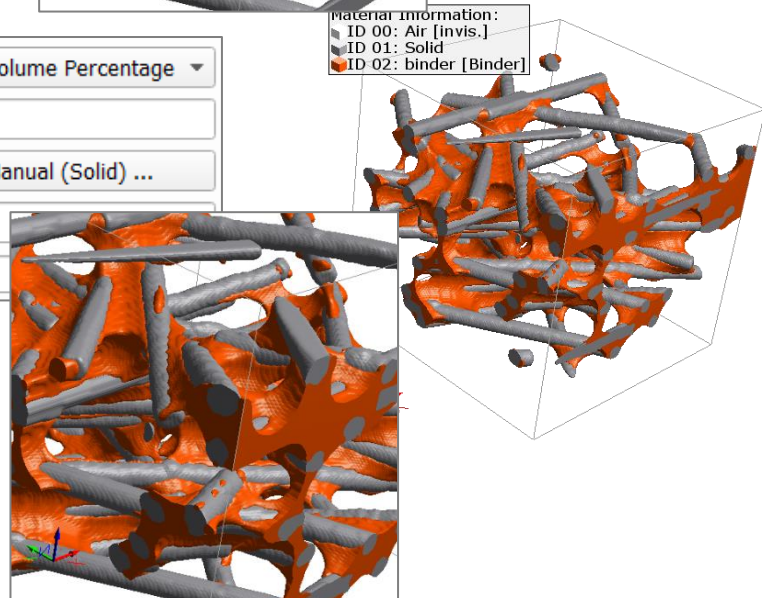



BINDER ANISOTROPY FACTOR

The **Binder Anisotropy Factor** allows to control the grade of binder anisotropy in the X-Y-plane. If the factor is the default value of 1, the binder is distributed isotropically. By choosing larger values, the binder is distributed in the XY-plane but then, the contact angle value is not accurate anymore.

Observe the effect of changing the **Binder Anisotropy Factor** from (the default) 1 to 3 when adding binder.

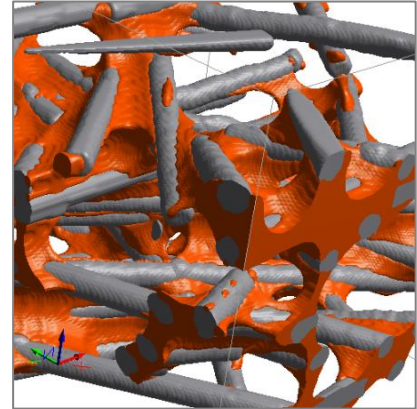
Stopping Criterion	Solid Volume Percentage ▾
Added Solid Volume Percentage / (%)	5
Binder Material (ID 02)	 Manual (Solid) ...
Contact Angle / (°)	0
Binder Anisotropy Factor	1



Stopping Criterion	Solid Volume Percentage ▾
Added Solid Volume Percentage / (%)	5
Binder Material (ID 02)	 Manual (Solid) ...
Contact Angle / (°)	0
Binder Anisotropy Factor	3

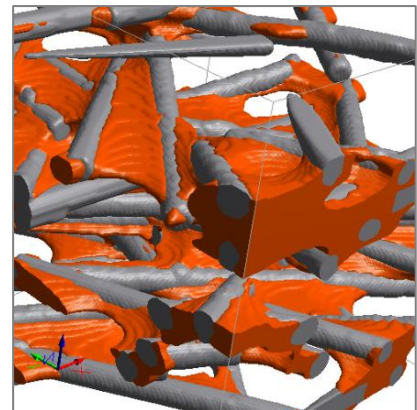

PERIODICITY

When the 3D-structure model is periodic in one or more directions, the binder can be added periodically: in all directions, only in the selected direction (**Periodic X**, **Periodic Y** and/or **Periodic Z**), or non-periodically. Adding binder periodically in certain direction(s) only makes sense if the 3D-structure model is periodic in that/those direction(s).

STOP ITERATION BY

FiberGeo adds binder through an iterative process, which is repeated until the stopping criterion is fulfilled.

The stopping of the iterative process is controlled by checking and setting values for **Tolerance**, **Maximal Iterations**, or **Maximal Run Time (h)**.

Tolerance is the allowable amount of absolute variation between the entered target value for the selected stopping criterion (Solid Volume Percentage, Weight Percentage, or Grammage) and the value reached by the algorithm.

The user may also choose to have the addition of binder stop by a certain number of **Maximal Iterations** or **Maximal Run Time (h)**.

Information on the stopping of the algorithm and the number of iterations can be found in the Result Viewer of the *.gdr result file.

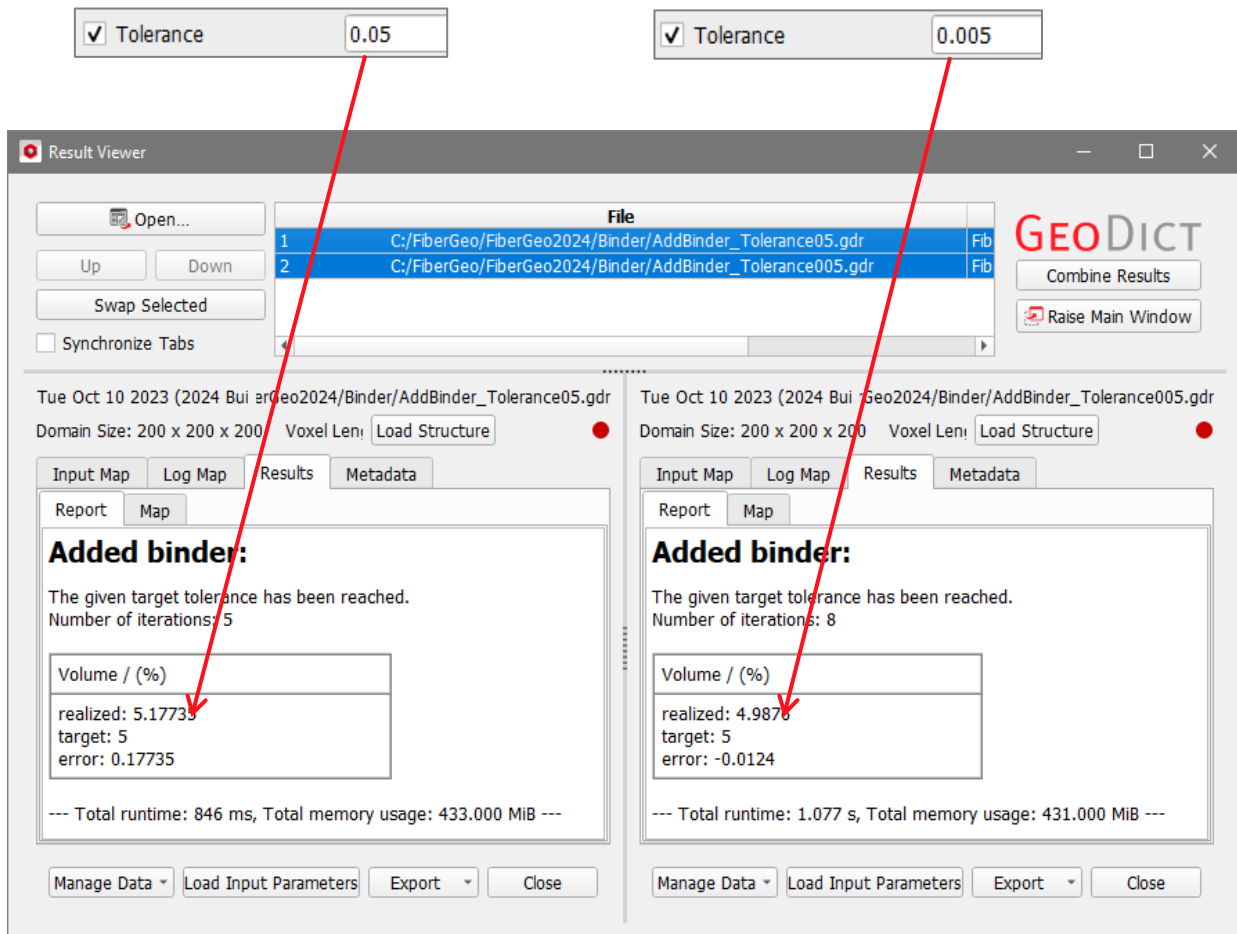

APPLY SOLID VOLUME PERCENTAGE / WEIGHT PERCENTAGE / GRAMMAGE CORRECTION AFTER ITERATIONS

Adding binder with the algorithm adds binder until the iteration stops according to the given stopping criteria. Thus, the given value for **Solid Volume Percentage / Weight Percentage / Grammage** is usually not reached precisely and there are few cases, where the algorithm even does not converge.

If the amount of binder should be reached perfectly, it can be corrected, by checking **Apply Solid Volume Percentage Correction after Iterations**, **Apply Weight Percentage Correction after Iterations** or **Apply Grammage Correction after Iterations** depending on the chosen stopping criterion.

Selecting this option adds or removes binder surface voxels after the iterations are stopped till the given binder value is reached precisely.

Note that this reduces the **Contact Angle** precision

General Options
Binder Distribution

Stopping Criterion Solid Volume Percentage ▾

Added Solid Volume Percentage / (%)

Binder Material (ID 02) Manual (Solid) [Binder]...

Contact Angle / (°)

Binder Anisotropy Factor

Periodicity

X-Direction
 Y-Direction
 Z-Direction

Stop Iteration by

Tolerance
 Maximal Iterations
 Maximal Run Time / (h)

Apply Solid Volume Percentage Correction after Iterations

Apply Weight Percentage Correction after Iterations

Apply Grammage Correction after Iterations

If the realized amount of binder after the iterations is larger than the target value, voxels are removed from exposed positions, i.e. voxels with only one contact to another binder voxel.

Apply Solid Volume Percentage Correction after Iterations

Material Information:

ID 00: Air [Invis.]

ID 01: Solid

ID 02: Binder (Solid)

The given target tolerance has been reached.
Number of iterations: 5

Volume / (%)
realized: 5.17735
target: 5
error: 0.17735

Apply Solid Volume Percentage Correction after Iterations

Material Information:

ID 00: Air [Invis.]

ID 01: Solid

ID 02: Binder (Solid)

The given target tolerance has been reached.
The SVP-correction was successful.
Number of primary iterations: 5
Number of secondary iterations: 0

Volume / (%)
realized: 5
target: 5
error: 0

In the other case, if the amount of binder is smaller than the target value, the algorithm adds voxels on positions with the most binder voxel neighbors.

Apply Solid Volume Percentage Correction after Iterations

Apply Solid Volume Percentage Correction after Iterations

Material Information:

- ID 00: Air [Invis.]
- ID 01: Solid
- ID 02: Binder (Solid)

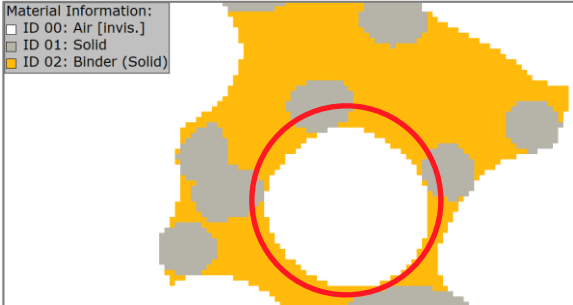

Material Information:

- ID 00: Air [Invis.]
- ID 01: Solid
- ID 02: Binder (Solid)

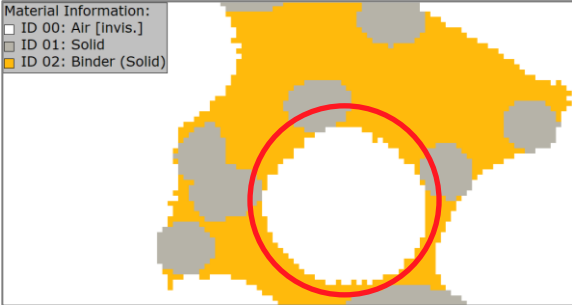

The given target tolerance has been reached.
Number of iterations: 7

Volume / (%)
realized: 5.61852
target: 5.8
error: -0.181475

The given target tolerance has been reached.
The SVP-correction was successful.
Number of primary iterations: 7
Number of secondary iterations: 3

Volume / (%)
realized: 5.8
target: 5.8
error: 0

In detail, the algorithm applies small dilations and erosions to keep a smooth surface. In detail four steps are performed:

1. First, a voxel-zone at the surface is defined by the smallest possible dilation / erosion.
2. Within this voxel zone the algorithm again applies dilations / erosions. This reduces the voxel zone further.
3. Afterwards only a small surface layer remains that is maximal one voxel thick.
4. These remaining voxels are randomly reassigned.

The random reassignment is done to prevent biased change of the curvature.

BINDER DISTRIBUTION

In real life, the process of adding binder to the material is affected by gravity and the viscosity of the binder, leading to inhomogeneous distributions. This effect can be modeled by defining a distribution of the binder under the **Binder Distribution** tab.

The default distribution is **Homogenous**, but it can be changed to a **Density Distribution in Z-Direction** to allow the modeling of inhomogeneity.

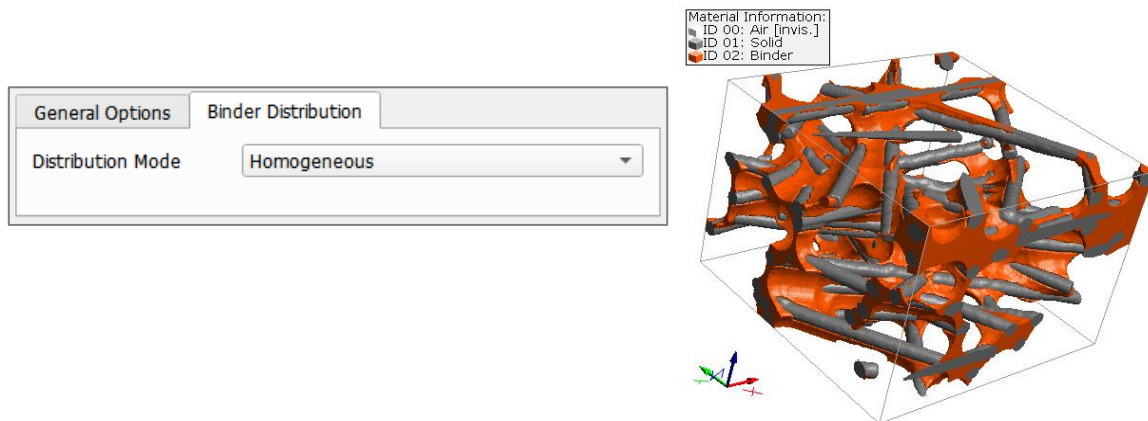

To model a **Density Distribution in Z-Direction**, we remove the inlet from the example by cropping (ProcessGeo → Process → Crop). This is necessary because the algorithm strives to reach the desired binder amount for each sub-segment and will try to add binder in the empty domain.

Alternatively, the amount of binder might be set to zero for these segments.

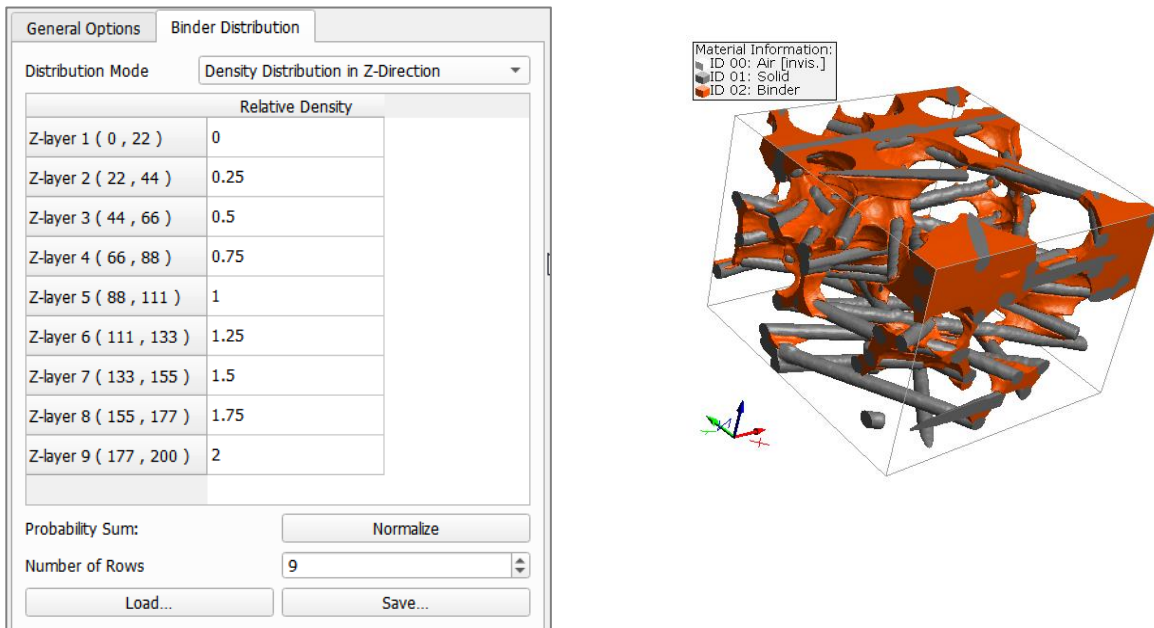

Enter the **Number of Rows** to define the number of Z-segments. To change the number of segments, change the **Number of Rows** to the number of segments desired.

In each segment, the binder is generated separately according to the parameters defined under the **General Options** tab. The **Added Solid Volume Percentage / (%)** is scaled with the normalized **Relative Density** given in the table of **Binder Distribution**.

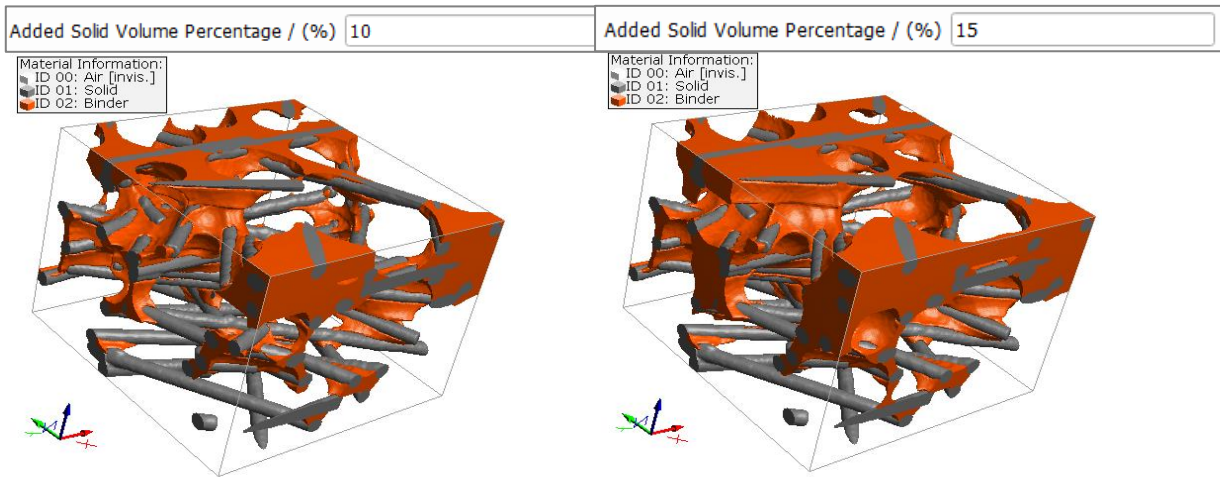

The **Binder Distribution** can be entered in form of a ratio in the **Relative Density** table.

In the images below, three different segments are clearly discernible with a binder distribution according to the relative values given in the table.

General Options Binder Distribution

Distribution Mode: Density Distribution in Z-Direction

Relative Density	
Z-layer 1 (0 , 66)	0.9
Z-layer 2 (66 , 133)	0
Z-layer 3 (133 , 200)	0.1

Probability Sum: 1

Number of Rows: 3

General Options Binder Distribution

Distribution Mode: Density Distribution in Z-Direction

Relative Density	
Z-layer 1 (0 , 66)	1
Z-layer 2 (66 , 133)	5
Z-layer 3 (133 , 200)	10

Probability Sum: 16

Number of Rows: 3

Material Information:
 ID 00: Air [Invis.]
 ID 01: Solid
 ID 02: Binder

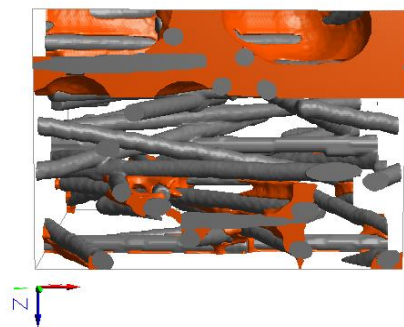

Material Information:
 ID 00: Air [Invis.]
 ID 01: Solid
 ID 02: Binder

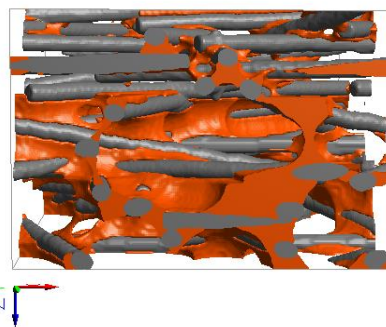

Clicking the **Normalize** button ensures the Relative Density values sum up to one. With the Buttons **Load...** and **Save...** the Distribution can be loaded/saved as text file which can be opened with other software as e.g. Microsoft Excel.

The parameters entered in the **Add Binder** dialog can be saved into *.gps (GeoDict Project Settings) files and/or loaded from them. Remember to restore and reset your (or GeoDict's) default values through the icons at the bottom of the dialog when needed and/or before every **FiberGeo** → **Add Binder** run. Resting the mouse pointer over an icon shows a tooltip explaining the icon's function.

FIBER GEOAPPS

When **Fiber GeoApps** is selected in the **FiberGeo** section, several representative fibrous structures can be chosen from the pull-down menu in the **Fiber GeoApps** panel.

Currently, four fibrous materials are predefined as GeoApps: Dewatering Felt, Rock Wool, Spunbond Nonwoven, and Two-Layer-Filter-Media.

When predefined materials are created, **GeoDict** macros corresponding to the generation of these predefined fibrous structures are called and executed. These macros are available in the **FiberGeo** folder in the **GeoDict** installation folder. They can be opened with a text editor to observe their syntax and the steps involved in the generation and can also be edited.

Add your own materials to the list of **Fiber GeoApps**, by moving the macros that generate them to the installation folder and restarting **GeoDict**.

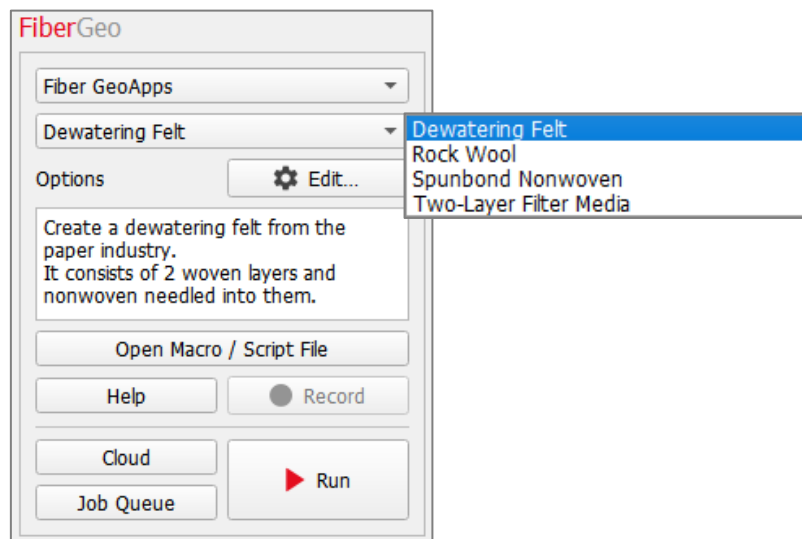

Click **Edit...** to open a dialog with the parameters defining these representative fibrous structures. They may be changed at will.

After modifications are done, clicking **Run** produces one of the modified predefined fibrous structures.

A result file (.gdr) and a folder with the same name, containing the analytic data file (GAD) of the fibrous structure, are automatically saved inside the project folder. The .gdr file can be opened in **GeoDict** through **File** → **Open Results (*.gdr) ...** in the menu bar.

After opening the .gdr file, the user can directly access all parameters used for the generation of these predefined structures by clicking the **Load Input Parameters** button at the bottom, and then selecting **Create** in the **FiberGeo** section pull-down menu and clicking the **Options' Edit...** button. In this way, all parameter values used for the generation are loaded into the **FiberGeo Create Options** dialog and can be examined in detail.

By clicking the **Open Macro / Script File** button, the macro file containing all steps for the generation of the predefined materials can be accessed.

FIBER GEOAPPS GALLERY

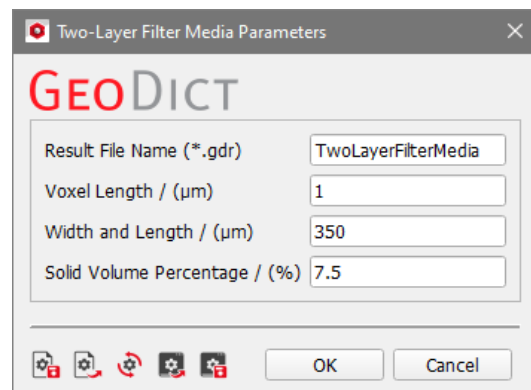
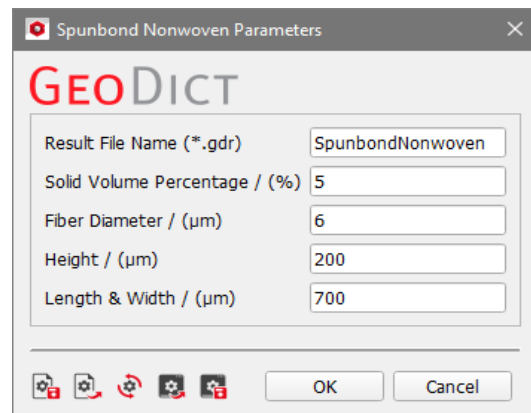
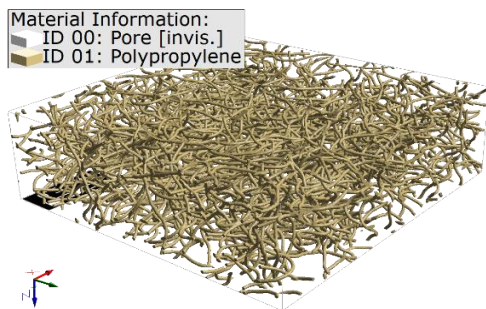
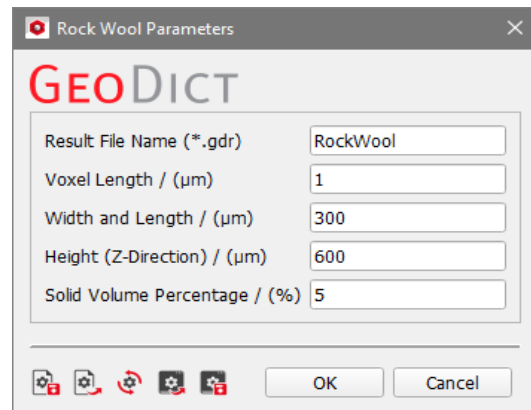
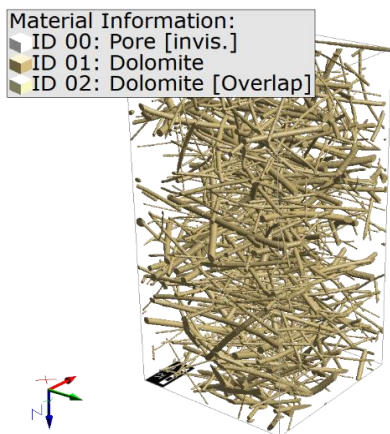
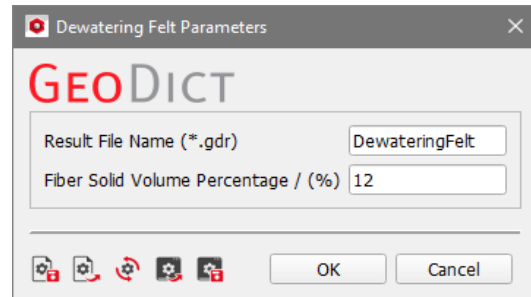
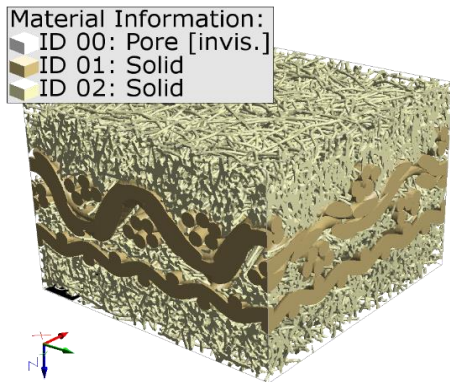

CREATE GAUSSIAN RANDOM FIELDS

GAUSSIAN RANDOM FIELD GENERATOR

A Gaussian random field describes a volume field with correlated noise. This means the probability of similarity between two values decreases exponentially with their distance. In the Gaussian Random Field Generator in **GeoDict**, several Gauss functions can be combined to define a random field.

The image on the right shows a scalar gaussian random field in a jet colour gradient. The corresponding Gaussian function has a standard deviation of 3.

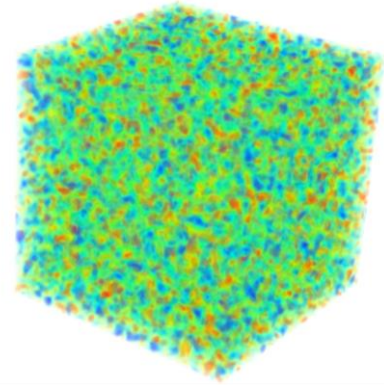

A Gaussian Random field then can be segmented to a structure:

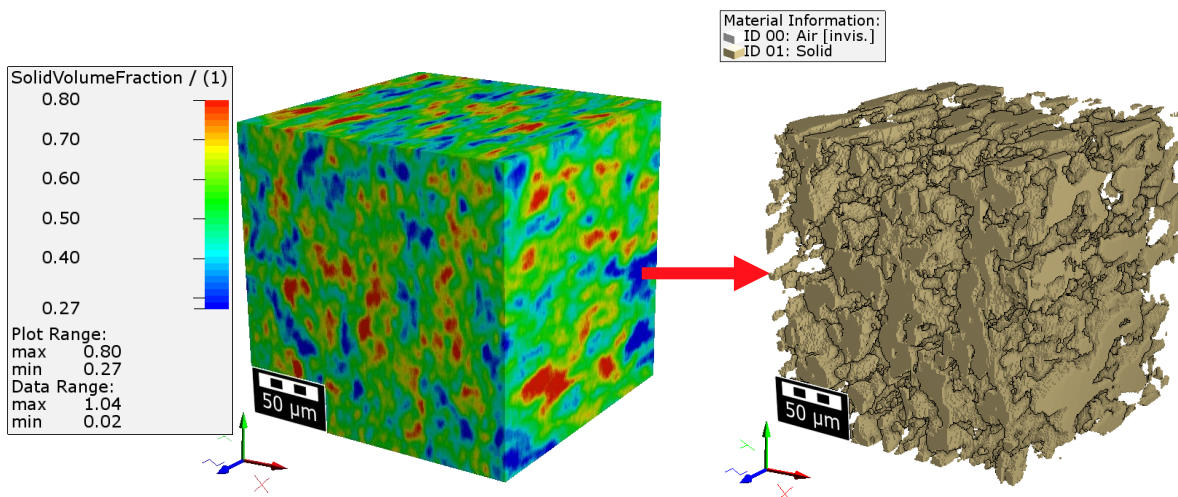

In the following example, observe different forms of noise:

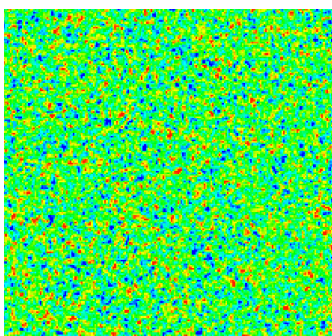

Uncorrelated noise, all values are independent

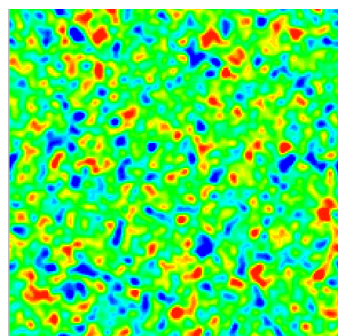

Noise following a spatial correlation. The values are correlated with their spatial neighborhood.

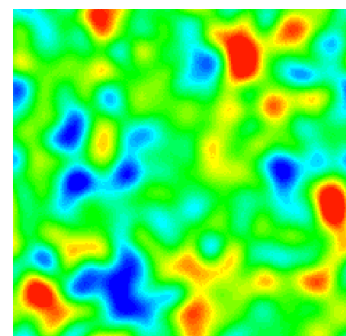

Noise following a spatial correlation with a large correlation length.

The spatial correlation can be specified with an autocorrelation function. For each distance between two voxels the probability of similarity, also called covariance, is described.

In the **Gaussian Random Field Generator**, the user may define several autocorrelation functions to generate a custom random field.

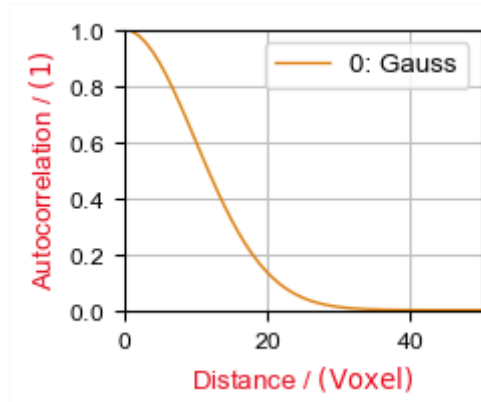

To open the **Gaussian Random Field Generator**, right-click on **Volume Field** in the **Project Status** section in the left-hand side of the **GeoDict** GUI and select **Create Gaussian Random Field**.

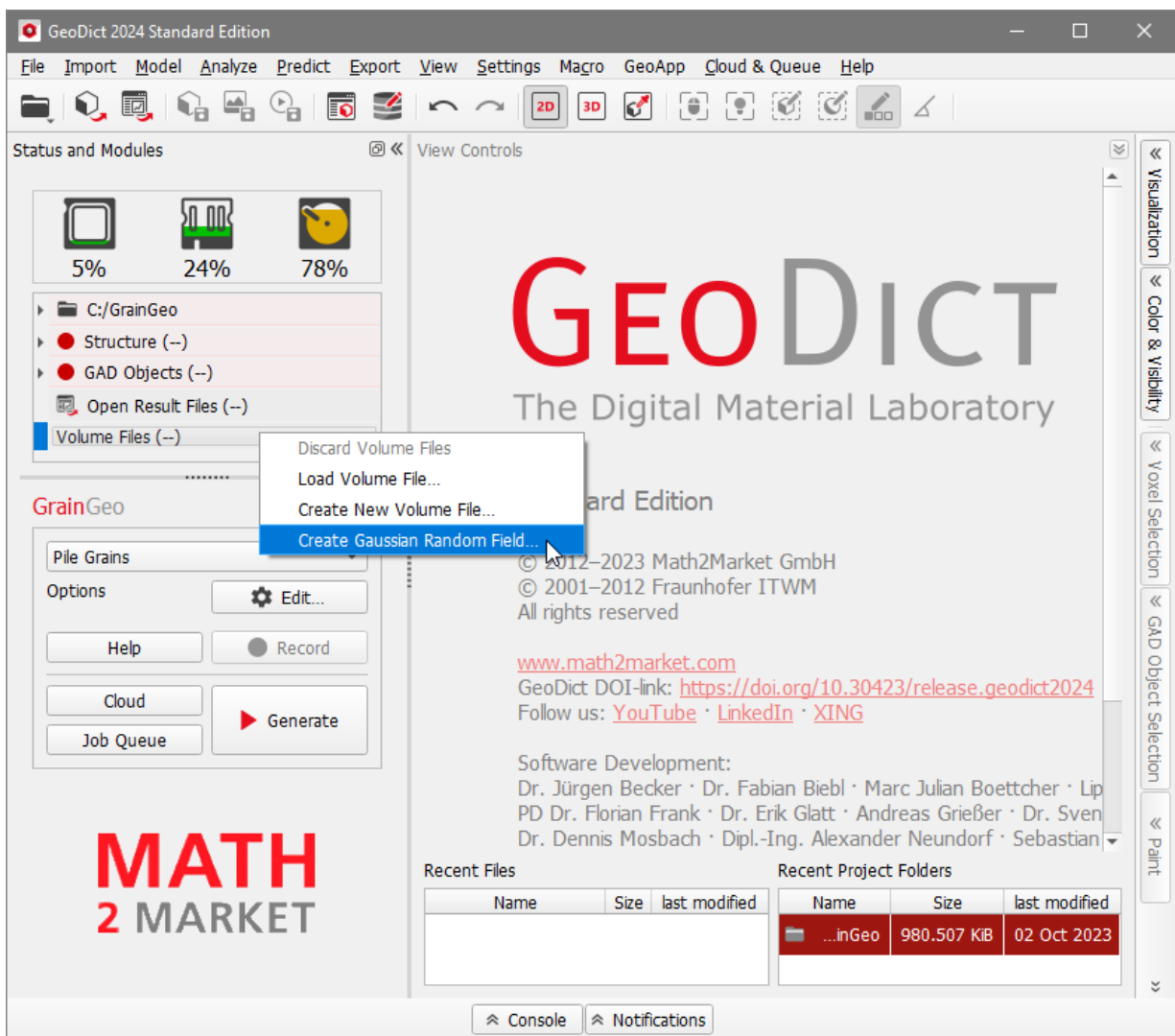

How to generate **Gaussian Random Fields** is documented in the [GrainGeo](#) handbook of the User Guide.

PARALLELIZATION

Parallel computing is applicable to the structure generation with **FiberGeo**. The number of thread parallel processes is set by selecting the **Settings** menu and opening the **Settings** dialog. The details of the settings can be found in the [GeoDict GUI, Menu and Toolbar](#) handbook.

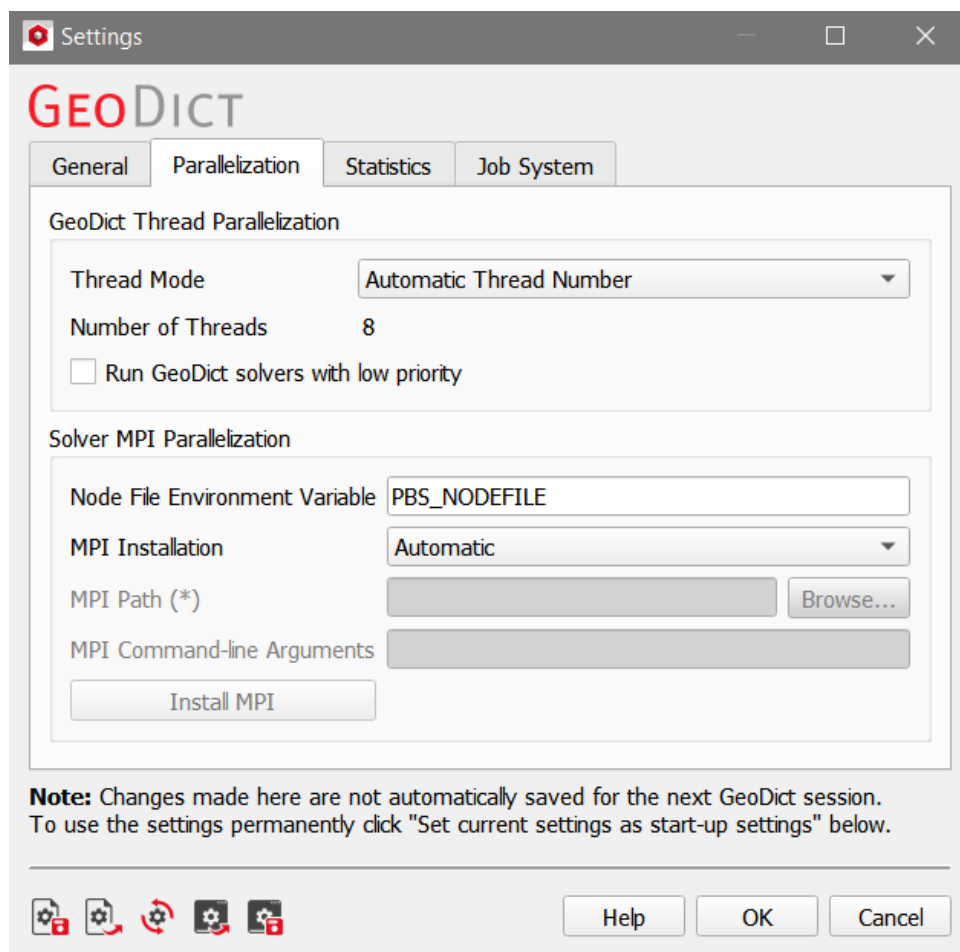
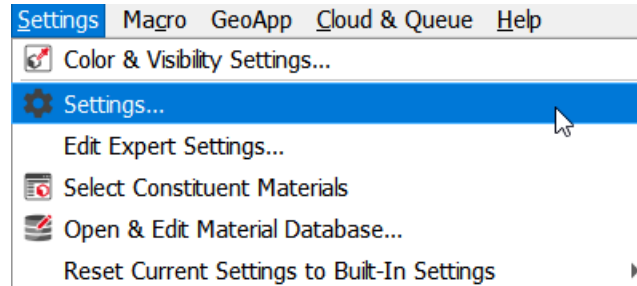

PARALLELIZATION BENCHMARK RESULTS

An example of a parallelization benchmark result is shown here. The computation ran on a server with 2xIntel E5-2697A v4 processors with 16 cores each, running with a maximum of 3.60 GHz, and 1024 GB RAM.

A Fibrous structure with the size of 1000 x 1000 x 1000 is created with **FiberGeo**. The solid volume fraction is 10% and **Without (Remove) Fiber Overlap** is selected with stopping criteria: 0% for **Overlap SVP** or 1000 for **Iterations**. Computations are done for 1,2,4,8,16,32 threads to compare the runtime.

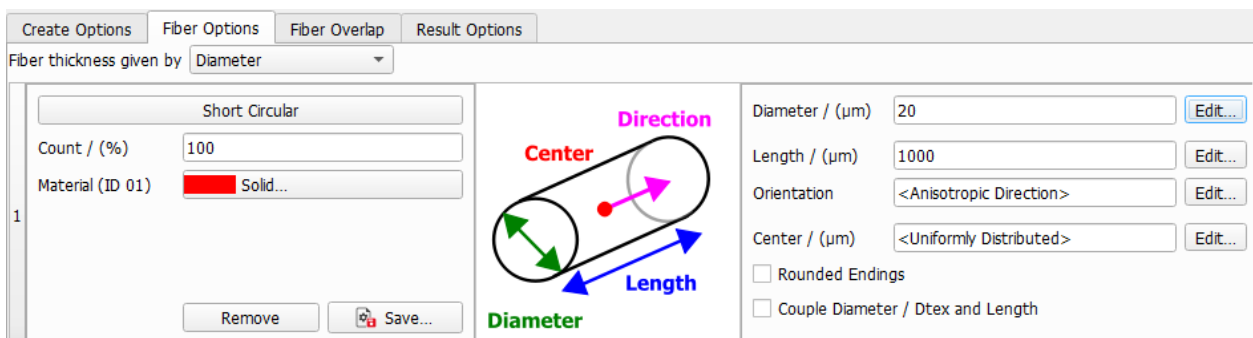
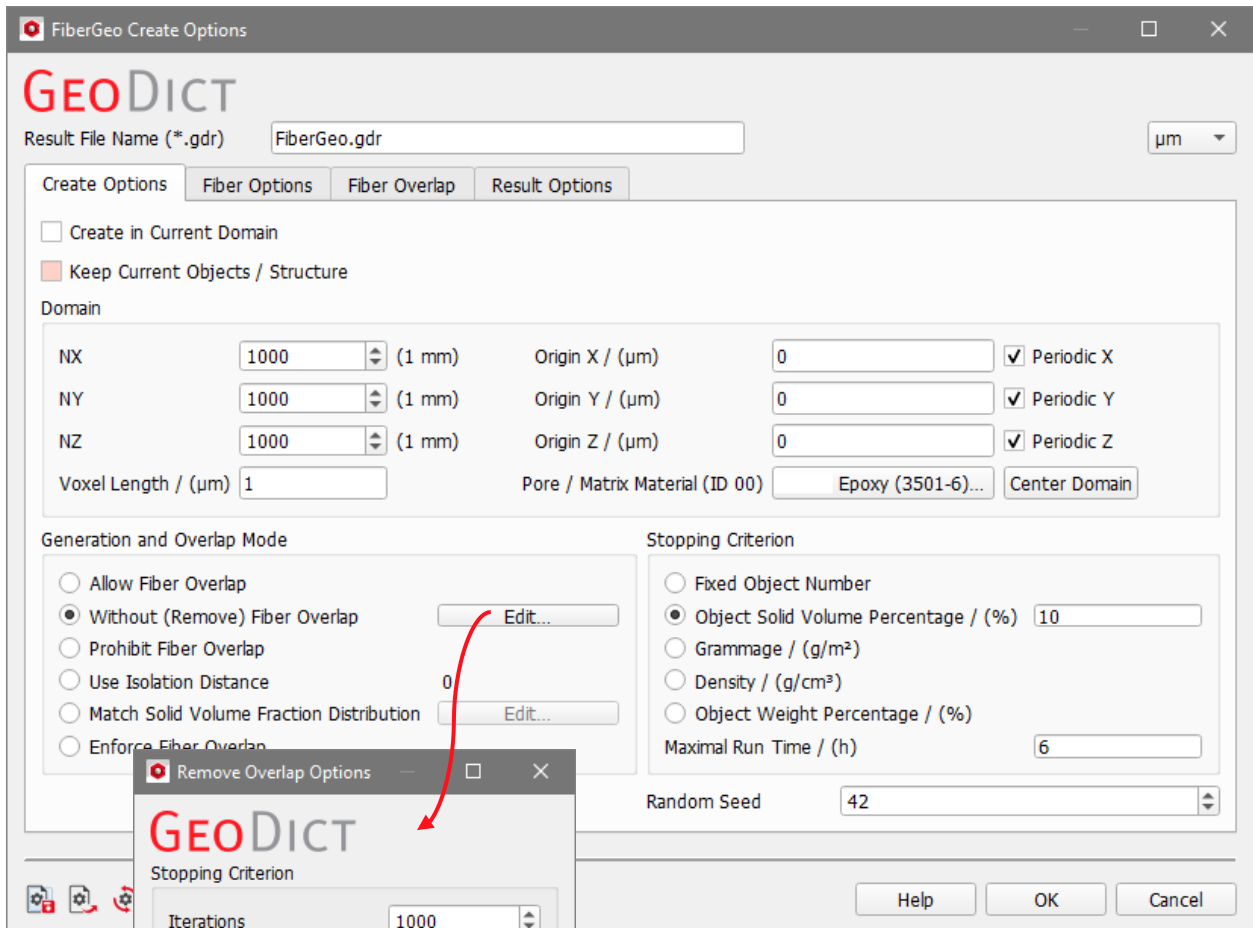

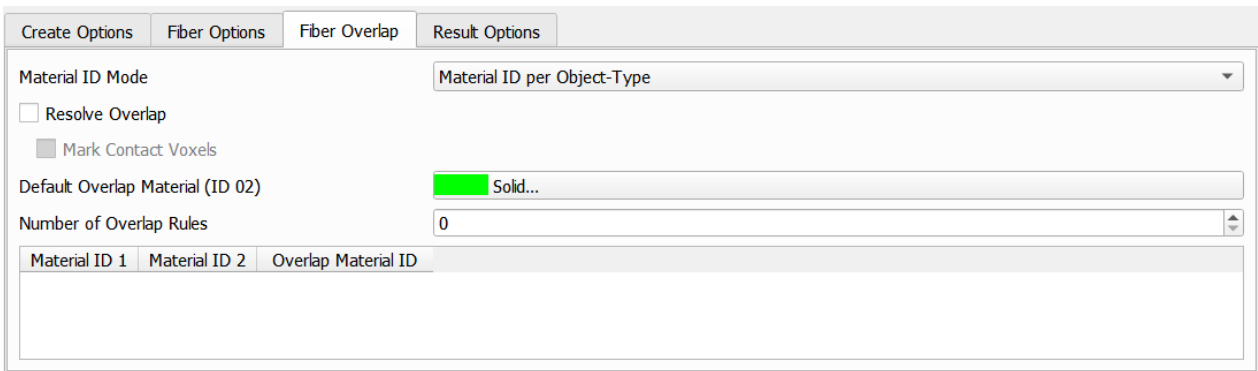

The generated fiber structure is shown here. The runtimes for a different number of processes are shown in the following figure. It is observed that the parallelization reduces the runtime significantly. With 4 processes the runtime is reduced by 70%.

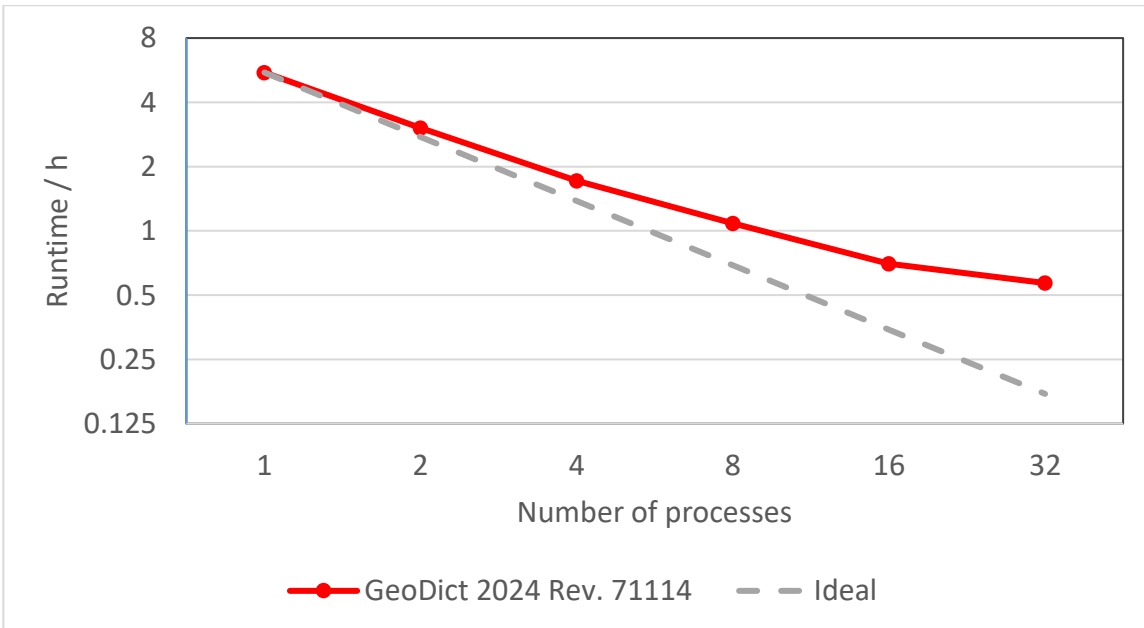
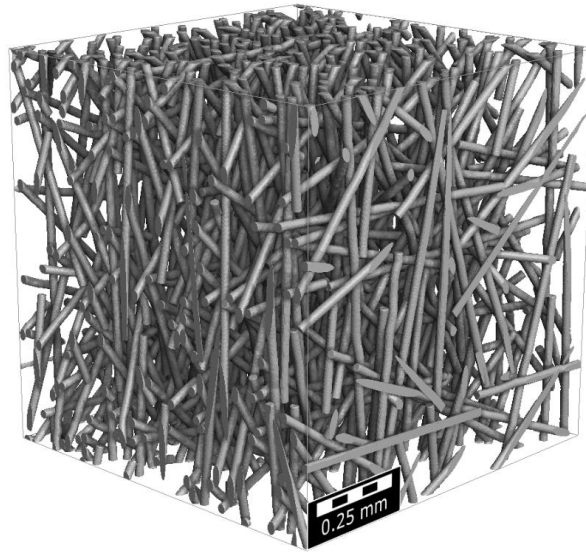

Technical
documentation:

Janine Hilden
Sebastian Rief
Barbara Planas

MATH
2 MARKET

Math2Market GmbH

Richard-Wagner-Str. 1, 67655 Kaiserslautern, Germany
www.geodict.com

© Fraunhofer Institut Techno- und Wirtschaftsmathematik ITWM, 2003-2011.

© Math2Market GmbH, 2011-2024. All rights reserved.