

GRAINGEO

User Guide

GeoDict release 2024

Published: May 2, 2024

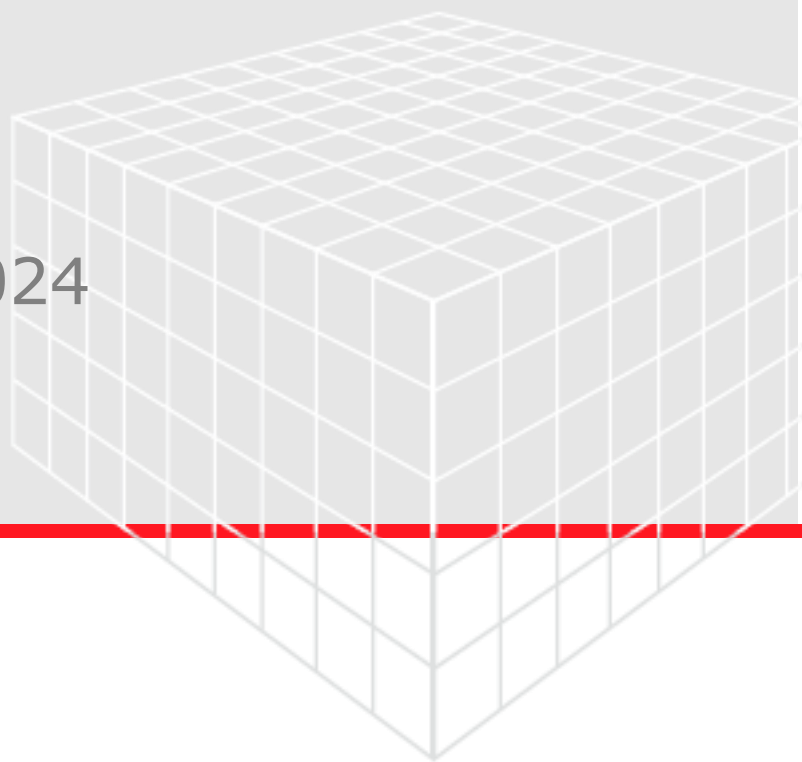

GEO DICT

<https://doi.org/10.30423/userguide.geodict>

© Math2Market GmbH 2024

Citation:

Janine Hilden, Sebastian Rief, Barbara Planas. GeoDict 2024 User Guide. GrainGeo handbook. Math2Market GmbH, Germany, doi.org/10.30423/userguide.geodict

All rights reserved. It is not permitted to reproduce the book or parts thereof in any form by photocopy, microfilm or other methods or to transfer it into a language suitable for machines, in particular data processing systems, without the express permission of the publisher. The same applies to the right of public reproduction.

The handbooks in the User Guide series of Math2Market GmbH can be obtained from:

Math2Market GmbH
Richard-Wagner-Strasse 1
67655 Kaiserslautern
Germany

Phone: +49 631 205 605 0
Fax: +49 631 205 605 99
Email: info@math2market.de
Web: www.math2market.de

GENERATE AND MODEL GRANULAR STRUCTURES	1
GRAINGEO SECTION	2
CREATE GRAINS	4
Create Options	5
Object Options	26
Object Overlap	65
Result Options	68
PILE GRAINS	69
Pile Options	70
Object Options	75
Object Motion	76
Result Options	82
PACK ANALYTIC SPHERES	83
Create New Packing	84
Re-Compact Existing Packing	93
PILE ANALYTIC SPHERES	94
STOCHASTIC FIELD THRESHOLDING	96
Create Options	98
Custom Generation Options	103
Result Options	110
DISTRIBUTE	112
SINTER & CRYSTALLIZATION	116
GROW SEDIMENT	121
ROUGHEN SURFACE	125
ADD BINDER	132
General Options	133
Binder Distribution	140
GRAIN GEOAPPS	143
CREATE GAUSSIAN RANDOM FIELDS	147
GAUSSIAN RANDOM FIELD GENERATOR	147
Options	149
X, Y, Z Autocorrelation Settings	151
Results for Gaussian Random Fields	159
REFERENCES	162

GENERATE AND MODEL GRANULAR STRUCTURES

The module **GrainGeo** creates detailed 3D models of granular structures, sintered materials, and sphere packings and pilings with arbitrary object shapes.

Typical applications are replication of ceramics, soot particle filters, metamorphic rocks, polymer concrete, electrode materials, e.g. for Li-ion batteries, to mention only a few. In general, the spectrum ranges from powders and piled granular structures to sintered materials with open or closed porosity, up to densely sintered composite materials.

The starting point for modelling a granular structure is to define initial parameters, such as grain size distribution, pore size distribution or grain shapes. By starting the creation process, randomly distributed grain structures, pilings of various digital grains and sphere packings are generated according to these parameters. Resulting target parameters are e.g. the solid to volume percentage or the density of the final material. By varying the initial parameters, new model materials can be created, and their properties can be optimized. Optionally, a result file (*.gdr) from **GrainFind-Identify Grains** can be loaded (see the [GrainFind](#) handbook of this User Guide) to set the initial parameters.

The structures can be further processed by a simulated sintering process, growing sediments, redistribution of the grains or by adding binder. Examples for possible structures are shown in the figure below.

1. Define and vary initial and target parameters
Structure Size, Grain Shape, SVP, Density, ...
2. Create granular microstructures
Create Grains, Pile Grains, Pack Analytic Spheres
3. Postprocessing
Distribute, Sinter, Roughen, Add Binder, ...

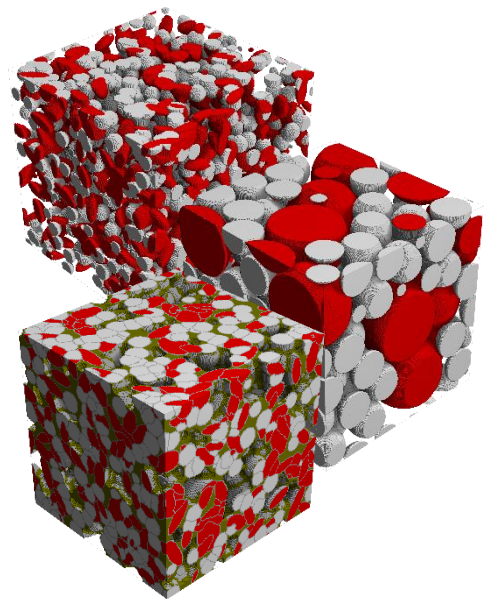

For more complex examples, see the [Grain GeoApps](#) (page [143](#))

With other **GeoDict** modules, the structures can be further analyzed and processed: Geometric properties like pore-size distribution (**PoroDict**) and transport properties like tortuosity, effective diffusion, and effective electrical and thermal conductivity (**ConductoDict**, **DiffuDict**) can be calculated. Flow resistivity (permeability, pressure drop), filter efficiency, filter capacity, and many more, can be computed using e.g. **FlowDict**, **FilterDict** and **AddiDict**. Mechanical large deformation and stress/strain curves can be simulated using **ElastoDict** and the charging of battery electrodes can be analyzed with **BatteryDict**.

The generated models are available as 3D images and can be exported for further processing using additional software. Using **ExportGeo-CAD**, the structures can be meshed and exported as well.

GRAINGEO SECTION

To open the GrainGeo module, select **Model** → **GrainGeo** in the GeoDict GUI menu bar. In the GrainGeo section, a pull-down menu lists all available GrainGeo commands.

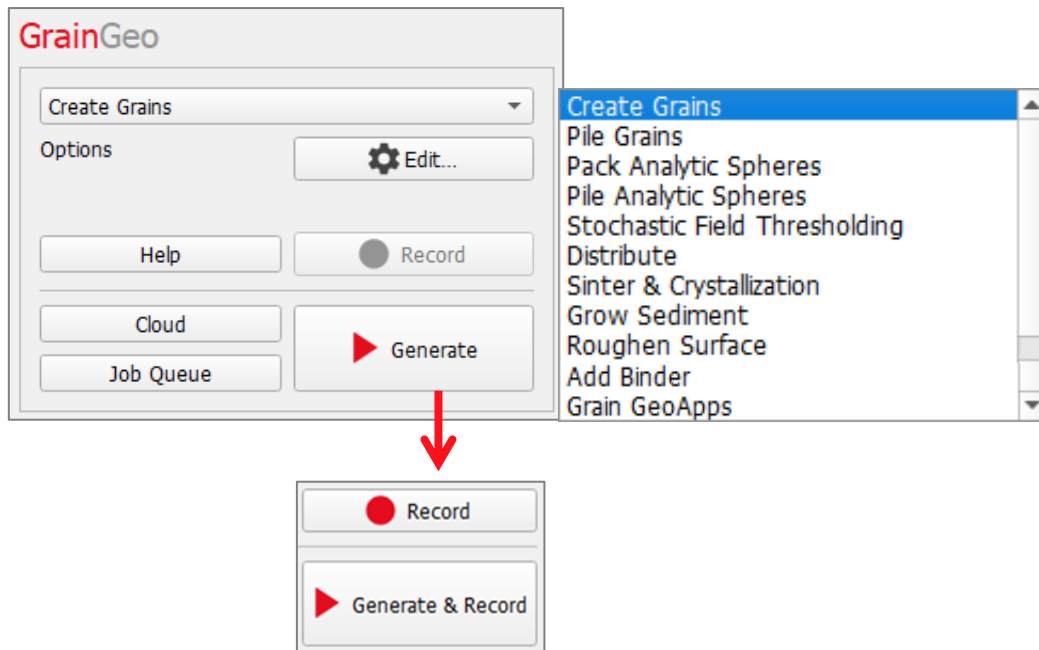

- **Create Grains** generates granular structures with user-defined parameters.
- **Pile Grains** simulates grains falling, rotating and finally settling to create the structure. Arbitrary objects can be chosen as grains.
- **Pack Analytic Spheres** creates dense sphere packings close to the maximal possible packing density given a fixed number of spheres and a user defined distribution of sphere sizes.
- **Pile Analytic Spheres** is faster and might lead to denser packings than **Pile Grains**, but it is limited to spheres.
- **Stochastic Field Thresholding** creates a structure by segmenting a user-defined stochastic field following selected threshold criterions.
- With **Distribute**, grains can be redistributed in the domain to create a more homogeneous material.
- **Sinter & Crystallization** simulates a sintering process by compressing the structure currently in memory. The packing density is maximized, and grain boundaries can be formed.
- With **Grow Sediment**, new material is applied to the existing objects.
- Through **Roughen Surface**, the surfaces of objects in the granular structure are roughened with small grains.
- **Add Binder** adds material in the shape of a concave meniscus in locations where objects in the structure are close together. The addition of binder in granular structures can be modeled this way.
- **Grain GeoApps** creates predefined materials from different application areas.

After selecting a command from the pull-down menu, the necessary parameters can be entered through the corresponding **Options' Edit ...** button located in its panel.

After setting the input parameters for the selected GrainGeo generation, clicking **Generate** in the GrainGeo section starts the generation. The granular structure is created and shown in the **Visualization** area.

Macro files are recorded and saved when selecting **Macro → Start Macro Recording...** in the menu bar. When recording a macro, **Record** becomes active and **Generate** changes to **Generate & Record**.

Click **Cloud** to run it in the GeoDict cloud. Click **Job Queue** to run the grain generation on machines connected in your local network (see the [High Performance Computing handbook](#) of this User Guide for details). If interested in cloud simulations or job queueing, contact Math2Market to apply for a GeoDict cloud or job queueing license.

The commands **Create Grains**, **Pile Grains**, **Pack Analytic Spheres**, **Pile Analytic Spheres**, **Stochastic Field Thresholding** and **Grain GeoApps** generate a new structure model or a new structure model in the domain or on the objects / structure currently in memory. All other processes require a valid initial structure already in memory.

If you save the parameters of the **Options** dialog into GPS (**GeoDict** Project Settings) files, you can reload them at will.

Remember to restore and reset your (or GeoDict's) default values through the icons at the bottom of the dialog when needed and/or before every GrainGeo run. Resting the mouse pointer over an icon prompts a Tooltip showing the icon's function to appear.



CREATE GRAINS

When choosing **Create Grains** from the pull-down menu, granular structures can be generated, either in an empty domain or on already existing structures. Clicking the **Options' Edit...** button in the **GrainGeo** section opens the **GrainGeo Create Options** dialog.

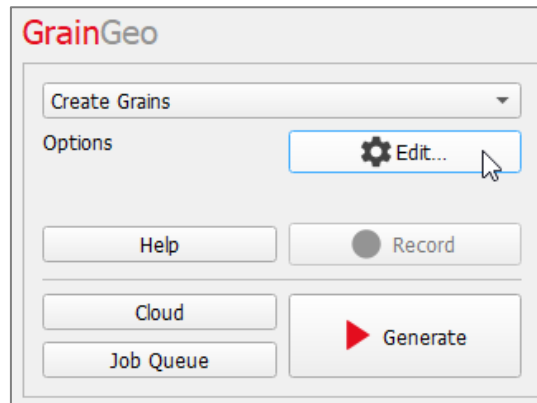

At the top left of the **GrainGeo Create Options** dialog, the name for the file containing the generation results can be entered in the **Result File Name (*.gdr)** box. The default name can be kept, or a new name can be chosen, fitting the current project.

The available units (**m**, **mm**, **µm**, **nm** and **Voxel**) are selectable from the pull-down menu at the top right of the **GrainGeo Create Options** dialog. When the units are changed, the entered values are adjusted automatically.

The **GrainGeo Create Options** dialog is organized using four tabs:

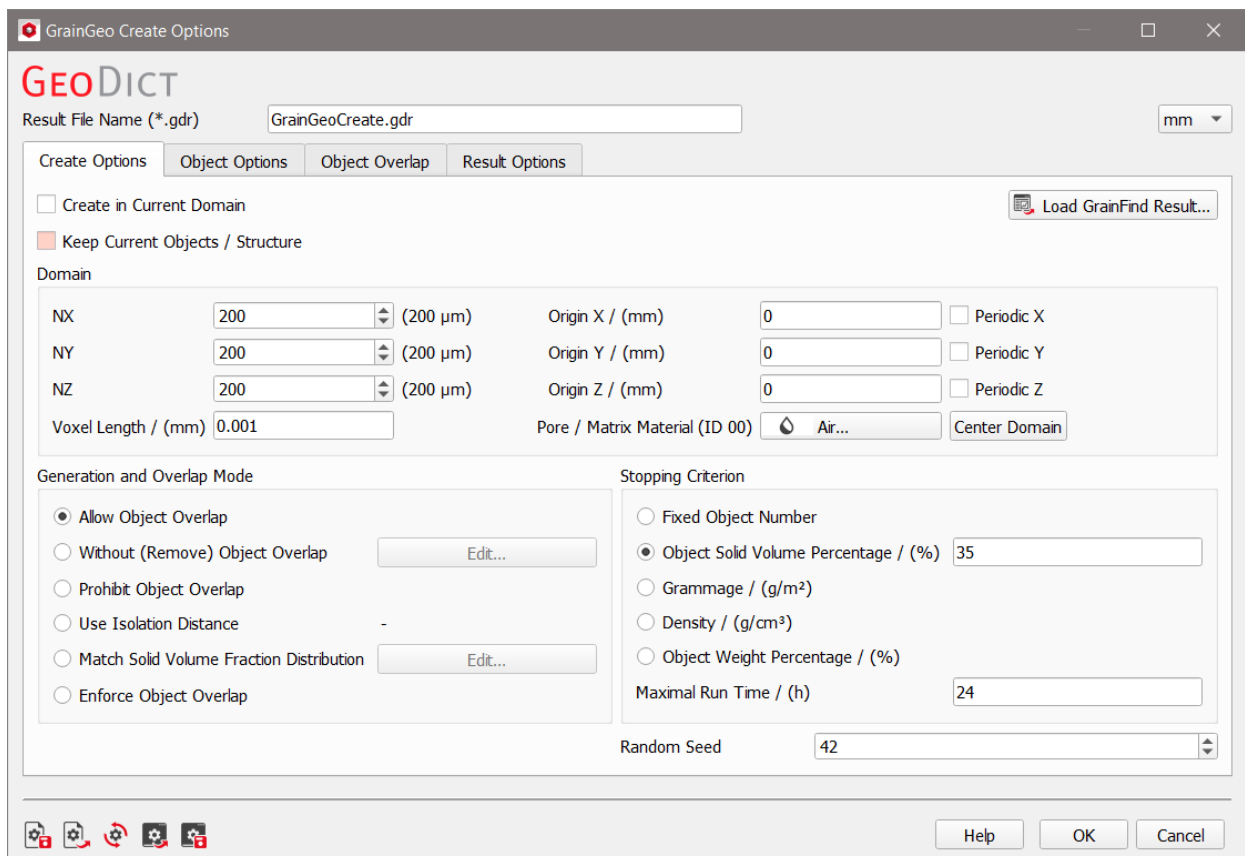

- **Create Options:** Determine general properties of the resulting structure, such as size, position, resolution, and solid volume fraction.
- **Object Options:** Define the geometrical properties of individual object types such as cross-section, length, and orientation. Up to eight different object types can be used in one structure.
- **Object Overlap:** Defines how the IDs of different materials and objects are assigned. This is relevant for overlap operations performed on the structure and to define different materials with respective properties in the structure.
- **Result Options:** Determine if and how the resulting geometry is saved.

The result files are saved in the chosen project folder (**File** → **Choose Project Folder**, in the Menu bar). If a **GeoDict** results file (*.gdr) with the given name already exists in the project folder, a warning message is shown at the start of the creation process. The user can either decide to back up the old file, to overwrite it, or to cancel and choose a new file name.

CREATE OPTIONS

The geometric properties of the desired granular structure are accessible under the **Create Options** tab. The parameters there are grouped under the panels **Domain**, **Generation and Overlap Mode**, and **Stopping Criterion**.

The screenshot shows the 'Create Options' dialog box with the following settings:

- Create in Current Domain
- Keep Current Objects / Structure
- Domain:**
 - NX: 200 (200 μm)
 - NY: 200 (200 μm)
 - NZ: 200 (200 μm)
 - Voxel Length / (mm): 0.001
 - Origin X / (mm): 0
 - Origin Y / (mm): 0
 - Origin Z / (mm): 0
 - Pore / Matrix Material (ID 00): Air...
 - Center Domain:
 - Periodic X:
 - Periodic Y:
 - Periodic Z:
- Generation and Overlap Mode:**
 - Allow Object Overlap
 - Without (Remove) Object Overlap
 - Prohibit Object Overlap
 - Use Isolation Distance
 - Match Solid Volume Fraction Distribution
 - Enforce Object Overlap
- Stopping Criterion:**
 - Fixed Object Number
 - Object Solid Volume Percentage / (%) 35
 - Grammage / (g/m²)
 - Density / (g/cm³)
 - Object Weight Percentage / (%)
 - Maximal Run Time / (h): 24
- Random Seed: 42

CREATE IN CURRENT DOMAIN AND KEEP CURRENT OBJECTS / STRUCTURE

When checking **Create in Current Domain**, the structure currently in memory, is considered during the generation of a new structure. Additionally, when **Keep Current Objects / Structure** is checked, the structure in memory is kept and combined with the newly generated granular structure.

This feature is used in combination with checking **Prohibit Object Overlap** or **Prohibit Overlap with Current Objects** (see below, pages [12ff.](#)) in the **Generation and Overlap Mode** panel. By this, complex models of granular structures can be generated. For example, the user can make copper spheres cover a mold that is later discarded.

Once **Create in Current Domain** is checked, the parameters grouped under the **Domain** panel are inactive, including the voxel length, because they are taken from the structure already in memory.

In the example below, a previously generated mold (current object / structure) is present in memory while spheres are added. **Prohibit Overlap with Current Structure** is checked to avoid the spheres from entering the mold, but the spheres can overlap each other. The spheres are automatically assigned as material ID 02, while keeping the initial structure (with Material ID 01).

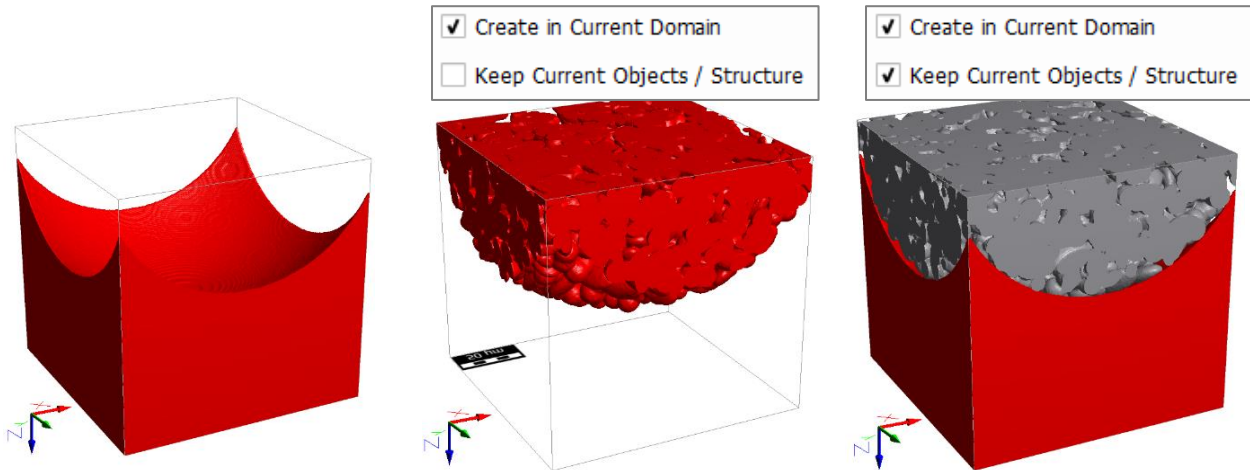

If the spheres should not overlap each other, nor the mold, either **Prohibit Object Overlap** or **Without (Remove) Object Overlap** should be checked. In general, both options avoid overlap between newly created objects, as well as between newly created and already existing objects. But while **Prohibit Object Overlap** recreates each object until the overlap is removed, **Without (Remove) Object Overlap** creates all objects at once and then shifts them until the overlap is removed. Nevertheless, with **Without (Remove) Object Overlap**, a residual overlap might be left. In most cases, the latter is faster and achieves a higher packing density and should therefore preferably be used.

DOMAIN

The **Domain** panel contains the parameters defining the structure size (**NX**, **NY**, and **NZ**) in combination with the resolution (**Voxel Length**), as well as the **Origin** parameters, the **Periodicity** checkboxes, the **Center Domain** button, and the **Pore / Matrix Material** button.

Domain			
NX	200	(200 μm)	Origin X / (mm)
NY	200	(200 μm)	Origin Y / (mm)
NZ	200	(200 μm)	Origin Z / (mm)
Voxel Length / (mm)	0.001		Pore / Matrix Material (ID 00)
			<input type="checkbox"/> Periodic X <input type="checkbox"/> Periodic Y <input type="checkbox"/> Periodic Z <input type="button" value="Air..."/> <input type="button" value="Center Domain"/>

NX, NY, NZ, and Voxel Length

The internal representation of a structure in GeoDict consists of rectangular 3D arrays of equally sized boxes, hereafter called volume elements or **voxels**.

NX, **NY**, and **NZ** are the number (N) of voxels in X, Y and Z directions.

The **Voxel Length** is the size of one voxel in the chosen units. Varying the values for NX, NY, and NZ has the effect of changing the size of the structure in the given direction.

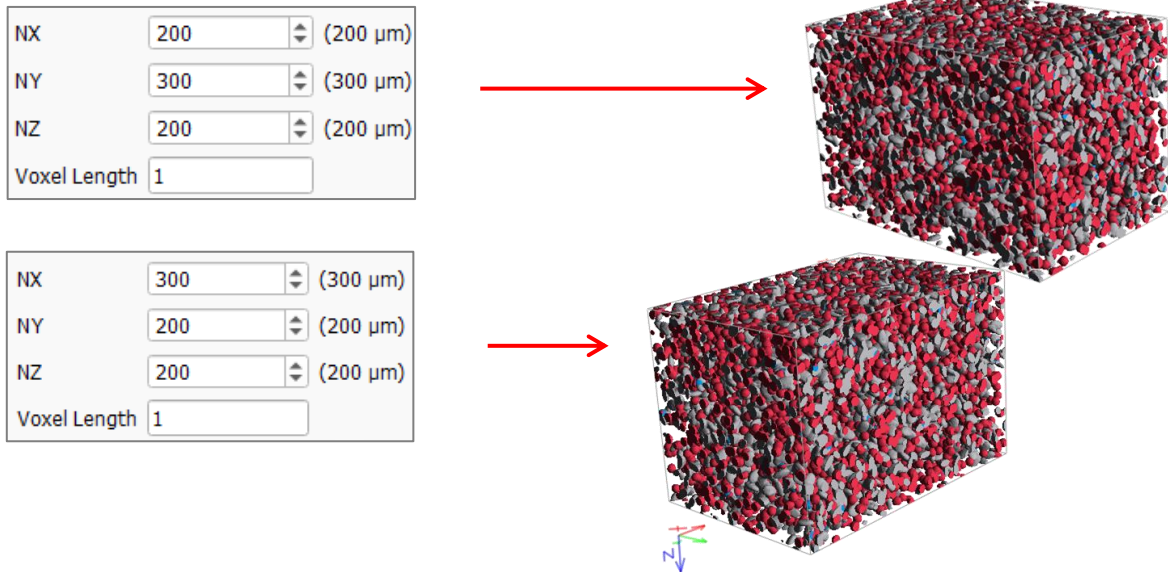

Low values for **Voxel Length** in combination with high values for **NX**, **NY** and **NZ** increase the resolution, but also increase computational time. After setting the values of **NX**, **NY**, and **NZ**, and **Voxel Length**, the physical structure size is automatically displayed in the chosen units (here μm).

The following example shows how starting with **NX** = 200, **NY** = 200, **NZ** = 200 (100 x 100 x 100 μm³, at voxel length 0.5 μm), and decreasing the **Voxel Length** from 0.5 μm to 0.25 μm has the effect of refining the structure by increasing the resolution, while decreasing the size of the volume to 50 x 50 x 50 μm³.

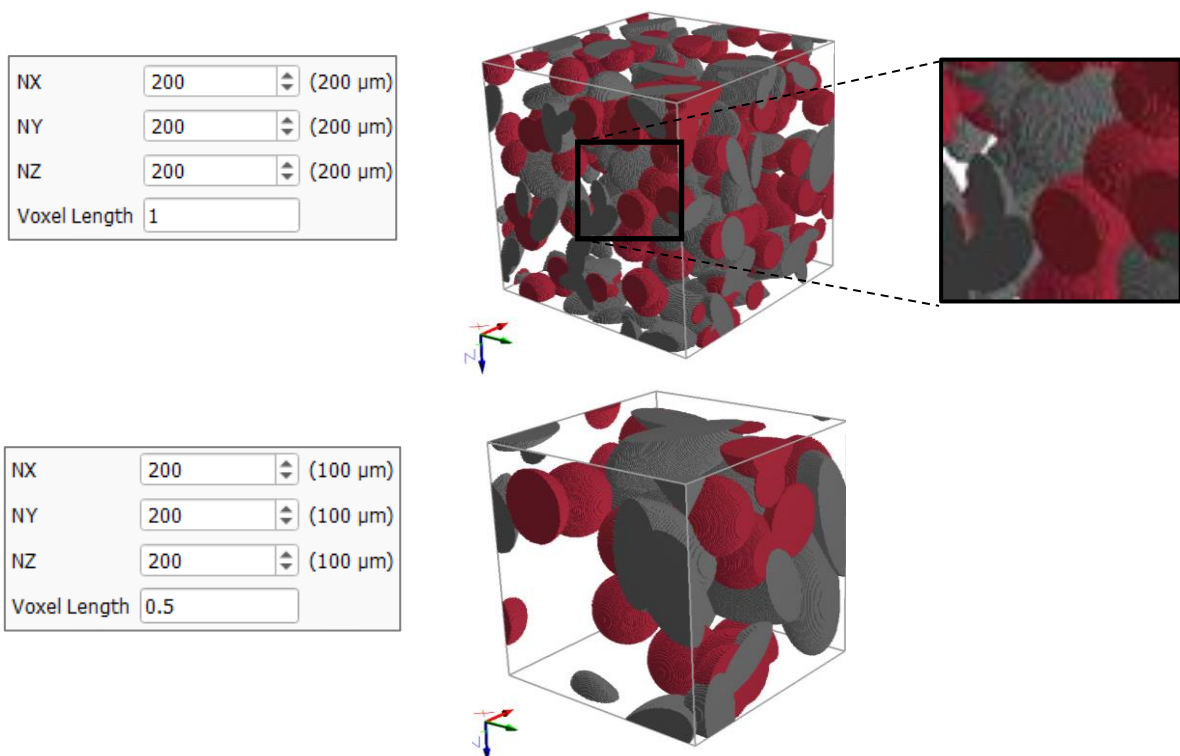

By setting **NX** = 400, **NY** = 400, **NZ** = 400, to restore the size of the volume to the original 100 x 100 x 100 μm^3 , the structure is displayed at higher resolution.

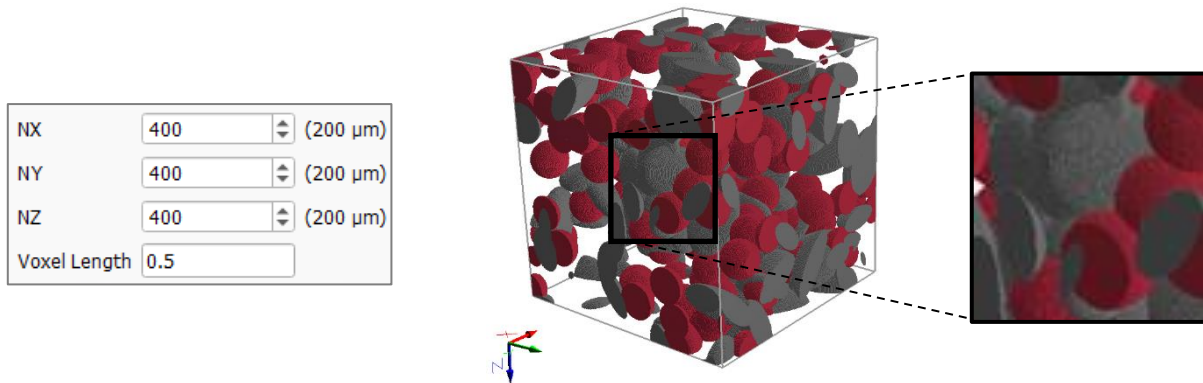

Origin X, Origin Y, and Origin Z, and Center Domain

The **Origin X**, **Origin Y**, and **Origin Z** parameters, together with the **Center Domain** button, determine the placement of the structure in the physical space. Zero values for Origin X, Origin Y, and Origin Z mean that the point with (0, 0, 0) coordinates is located at the lower left corner of the structure.

Entering values for Origin X, Origin Y, and Origin Z differing from (0, 0, 0) is useful in applications that require exact structure coordinates.

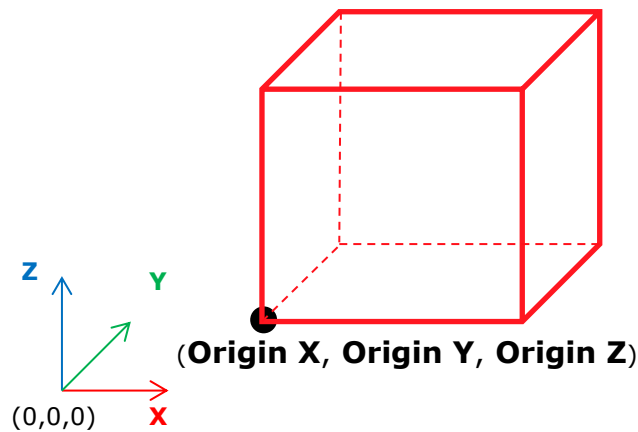

When clicking the **Center Domain** button, the (0, 0, 0)-point is set to the center of the structure.

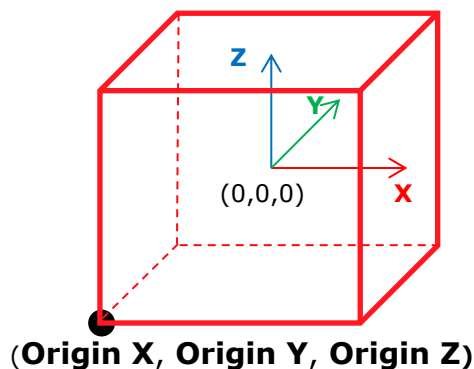

Periodicity

Checking the **Periodic X**, **Periodic Y**, and **Periodic Z** boxes allows the generation of structures which are periodic in one or several directions. Periodicity has the effect, that objects ending on one side of the volume reappear on the opposite side, so that merging of several volumes with periodic objects results in a repetitive complex.

Checking the **Periodic X** and **Periodic Y** boxes, but leaving un-checked the **Periodic Z** box, has the following effect on the periodicity of a generated granular structure.

Domain					
NX	200	(200 μm)	Origin X / (mm)	0	<input checked="" type="checkbox"/> Periodic X
NY	200	(200 μm)	Origin Y / (mm)	0	<input checked="" type="checkbox"/> Periodic Y
NZ	200	(200 μm)	Origin Z / (mm)	0	<input type="checkbox"/> Periodic Z
Voxel Length / (mm)	0.001		Pore / Matrix Material (ID 00)	Air...	Center Domain

This effect can be observed more closely, when processing the sample structure through **Model** → **ProcessGeo** (Repeat: X- 400 voxels, Y- 400 voxels, and Z- 400 voxels) and viewing it again from the three directions.

View → 3D Rendering

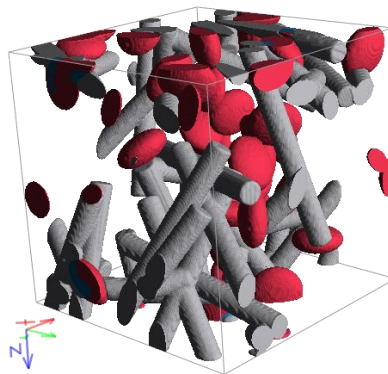

View → 2D Cross Section

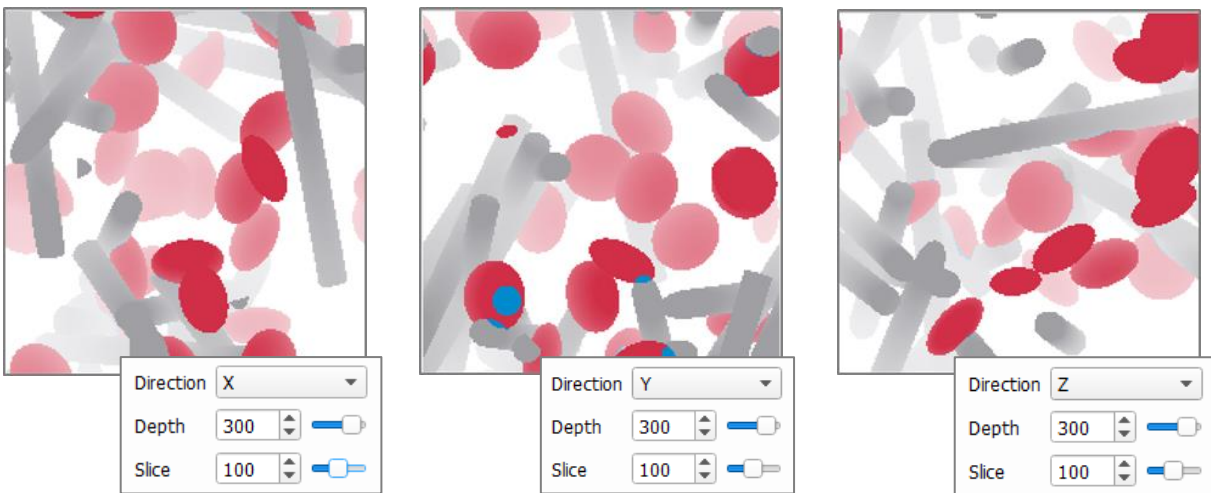

In the directions checked as periodic (**X** and **Y**), the short circular fibers and ellipsoids connect to each other across the repeated samples. In the direction checked as non-periodic (**Z**), the objects end at the edge of the sample.

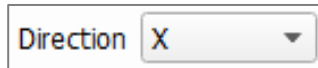
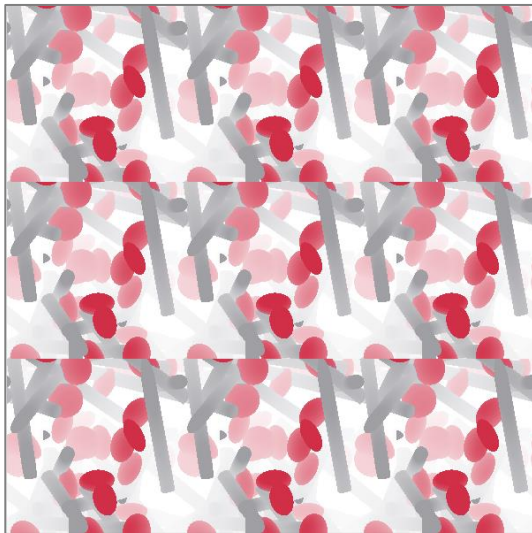
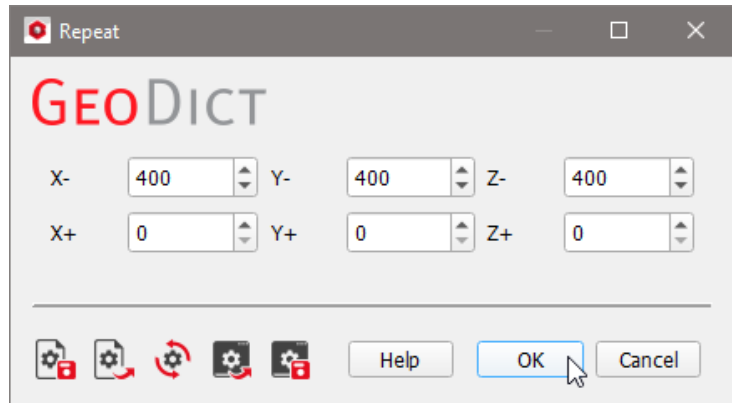
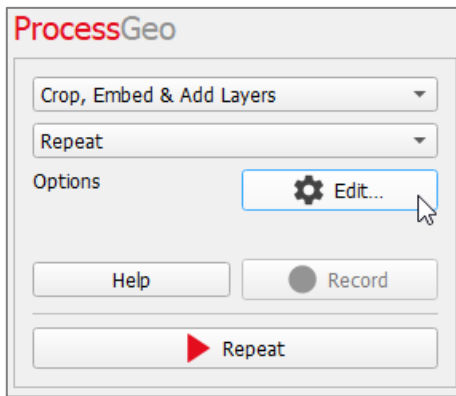

The structure shows periodicity in Y-direction, with unit cells passing smoothly into each other, and no periodicity in Z-direction, with unit cells appearing disconnected.

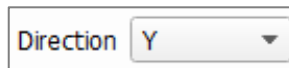
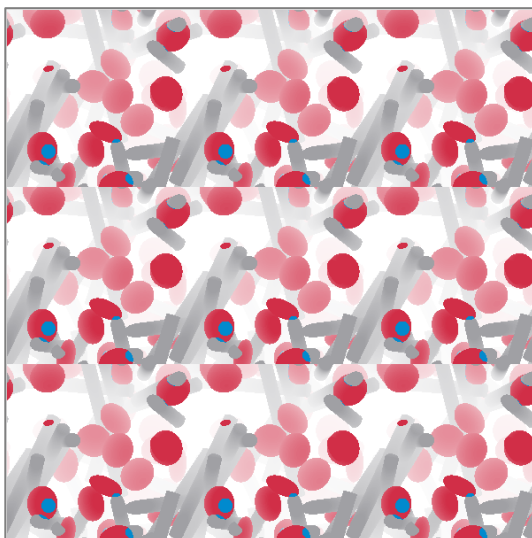
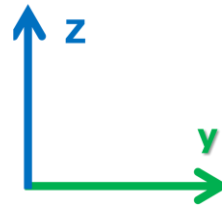

The structure shows periodicity in X-direction, with unit cells passing smoothly into each other, and no periodicity in Z-direction, with unit cells appearing disconnected.

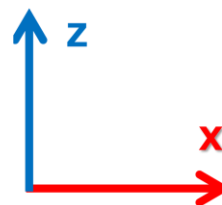

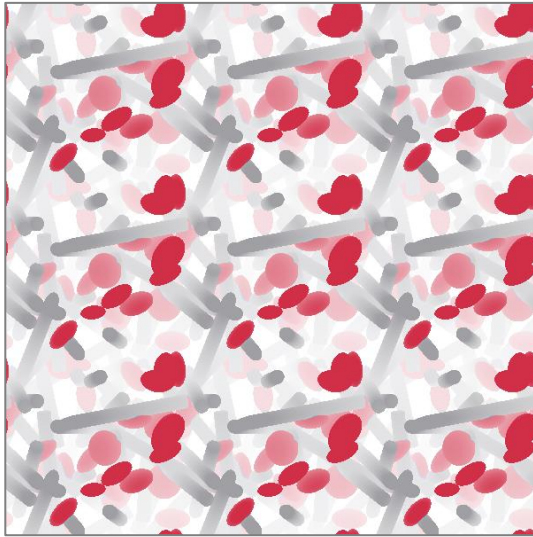

Direction

The structure shows periodicity in X- and the Y-direction, with unit cells passing continuously into each other in both directions.

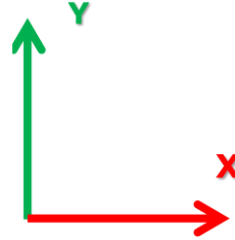

Pore / Matrix Material (ID 00)

When the matrix material with ID 00 is chosen to be **Pore**, the objects are embedded in empty pore space. Alternatively, the material filling the pore space can be a **Solid**, a **Porous** medium, or **Fluid**, in which the structural objects are embedded. The physical properties of the pore material can be attributed for simulations. The color and the visibility/invisibility can be chosen independently of the material.

Pore / Matrix Material (ID 00)

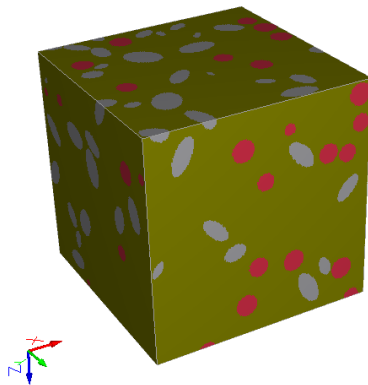

Pore / Matrix Material (ID 00)

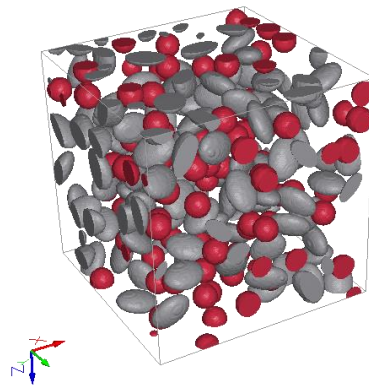

GENERATION AND OVERLAP MODE

The options in the **Generation and Overlap Mode** panel control the relative position among objects or of the structure currently in memory. It is possible to choose **Allow Object Overlap**, **Remove (Without) Object Overlap**, **Prohibit Object Overlap**, **Use Isolation Distance**, **Match Solid Volume Fraction Distribution**, **Enforce Object Overlap**.

Allow Object Overlap

Objects may overlap when selected.

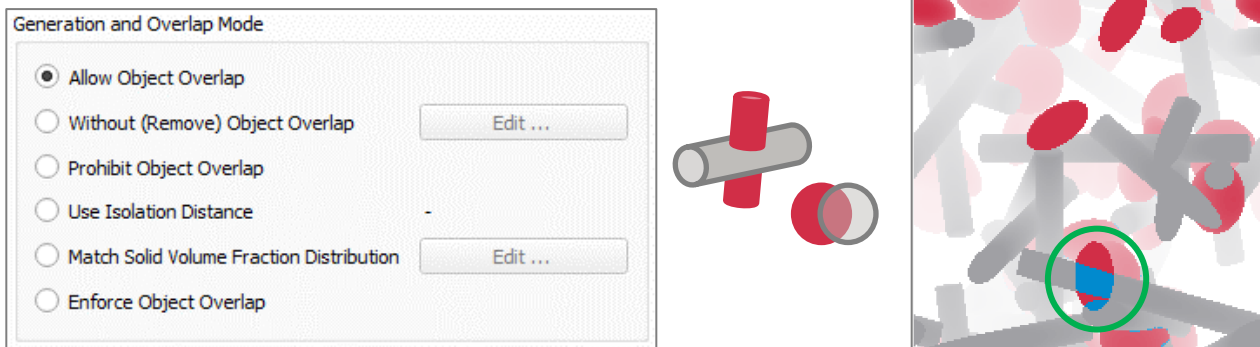

Without (Remove) Object Overlap

Checking **Without (Remove) Fiber Overlap** eliminates existing overlaps *after* the generation step. The user should consider that:

- Overlaps can be removed from:
 - Periodic structure models with objects smaller than the domain size. If objects longer than the domain size are present in the model, they might overlap with themselves. This type of overlap will not be removed.
 - Non-periodic structure models with arbitrary object sizes.
 - The statistical properties might change slightly after removing overlap.
 - The way in which the overlap removal occurs can be controlled through the **Remove Overlap Options** accessible via the **Edit ...** button.

In the **Remove Overlap Options** dialog, the following parameters can be set:

- **Iterations:** Defines after how many iterations the removal stops.
- **Iterations SVP Unchanged:** The removal stops if the **SVP (Solid Volume Percentage)**. See page [23](#)) remained unchanged during this number of iterations.
- **Overlap SVP / (%):** Defines the final allowed **Overlap SVP**.
- **Allow Object Shifts:** Check if shifting the objects should be an allowed operation for overlap removal. Define the **Number of Shifts** per iteration and the maximal **Shift Distance** per iteration.
- **Allow Object Rotations:** Check if rotating the objects should be an allowed operation for removal. Define the maximal **Number of Rotations** allowed per iteration. Objects will be rotated in all directions, where the maximal rotation angle per iteration is one degree.
- **Allow Fiber Deformations:** Check if bending fibers should be an allowed operation for overlap removal.

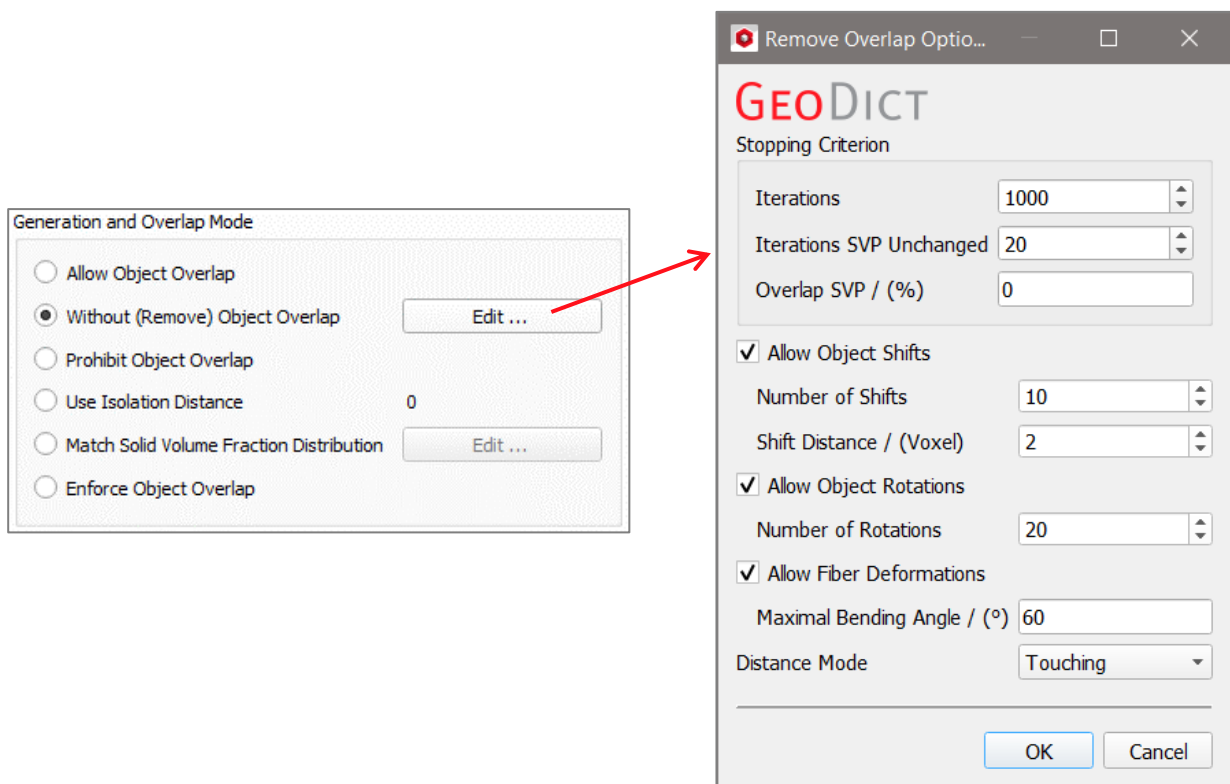

Define the **Maximal Bending Angle** allowed between two segments. Each fiber consists of several segments. The center points of the segment connections are shifted in all directions, while the other shape parameters, as e.g. fiber length and segment length are kept constant. The maximal point shift distance is the same as for the object shift. This option is only applied to fibers, as other objects do not consist of segments.

■ **Distance Mode:** The pull-down menu offers four options:

- The objects can be **Touching** (distance zero).
- Enter a maximal **Defined Overlap** allowed for the objects.
- Enter a minimal **Defined Isolation** distance for the objects.
- **Avoid Contacts** means a defined isolation of one voxel volume diagonal.

Note: While **Touching** works for all object types, the other three options cannot handle the object types **Combined Object**, **Intersected Object** and **Triangle**.

In a periodic domain, objects which are longer than the domain might overlap with themselves. This type of overlap cannot be removed. In this case, a message appears:

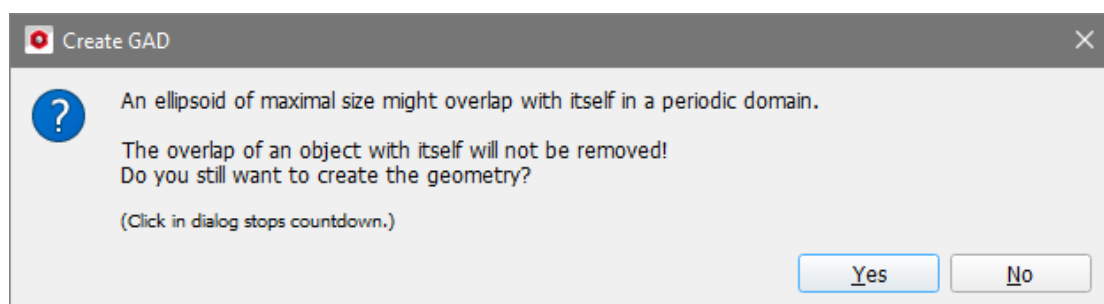

Prohibit Object Overlap

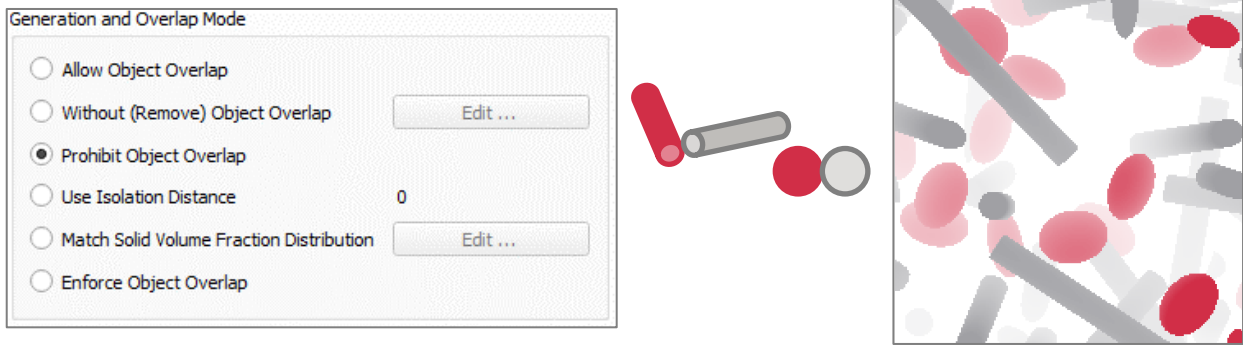

Objects may touch but not overlap when selected. In this case, the overlap of the objects is prohibited *during* the creation process. This option might lead to longer run times compared to **Remove Objects Overlap**. It only works for low volume percentages.

As mentioned above, objects longer than the domain might overlap themselves if a periodic domain is selected.

Use Isolation Distance

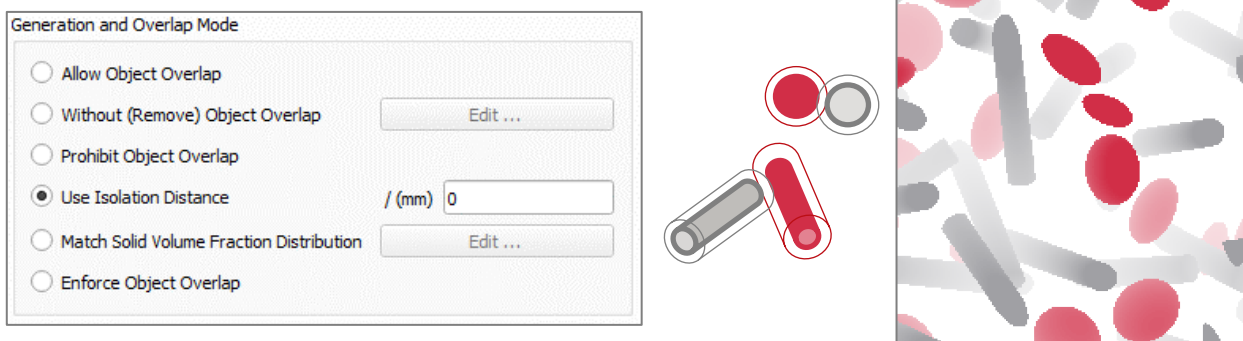

Inserting a positive value, the gaps between objects have at least this preset distance. When set to negative values (e.g. $-40\ \mu\text{m}$), the effect is that the objects may overlap maximally by $40\ \mu\text{m}$ (showing in a different color, here blue). While the distance mode **Defined Isolation** in **Remove Overlap** considers the objects, the **Use Isolation Distance** option only considers the voxel structure, and thus works for all object types.

Negative values for the isolation distance are useful to model synthetic objects that melt, or objects that deform at their touching points.

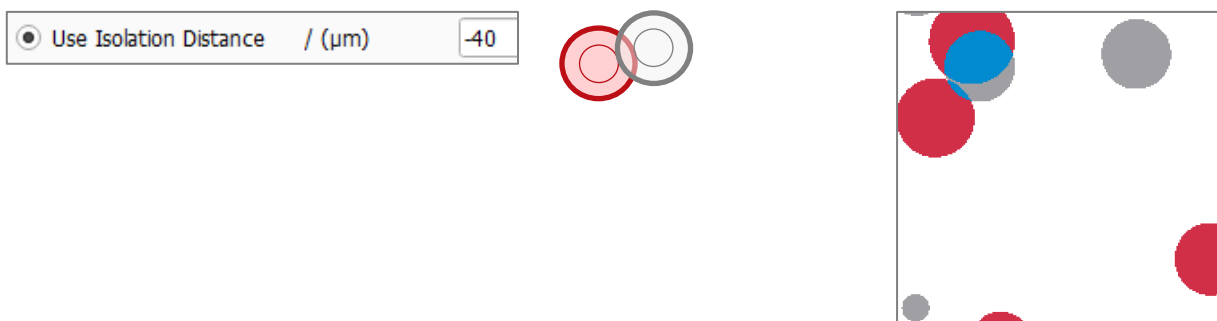

To create a structure with a **high packing density** and a defined isolation distance or overlap between the grains, use **Without (Remove) Object Overlap** with the respective **Distance Mode**, since the object shifts, rotations and deformations will ensure the packing density. With **Use Isolation Distance** as **Overlap Mode**, high packing densities cannot be achieved. In this case, the algorithm will not shift, rotate or deform the objects, but only generate the structure randomly until the isolation distance matches or the maximal runtime is reached.

Prohibit Overlap with Current Structure

If checking **Create in Current Domain** (see page 5), **Prohibit Overlap with Current Structure** appears instead of Match SVF Distribution. The objects in the newly generated structure can intersect with each other but not with those of the already existing structure.

Observe this effect in a structure with one (red) ellipsoid over which a new structure with blue and gray spheres is generated.

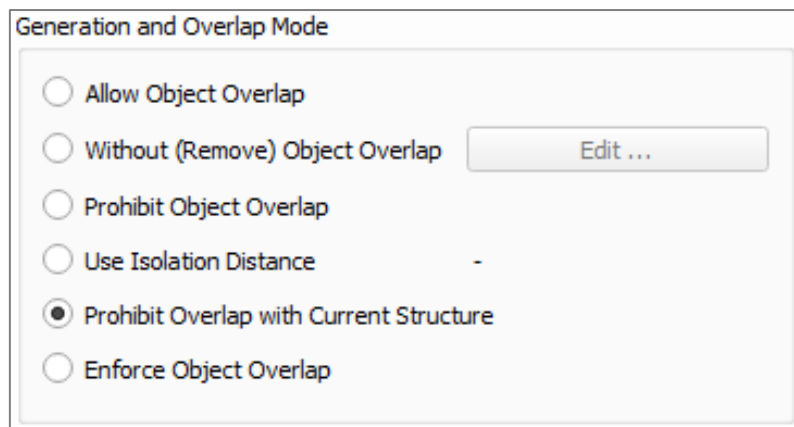

Whereas the blue and gray spheres overlap with each other, they do not overlap with the red ellipsoid.

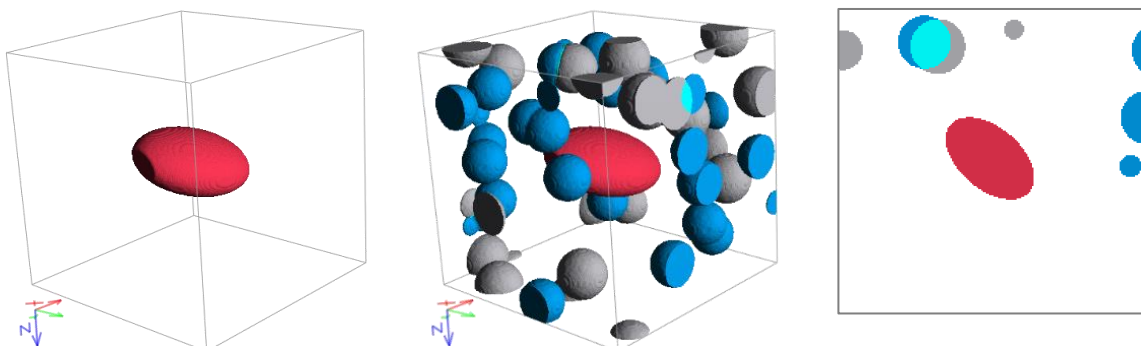

Match Solid Volume Fraction Distribution

For certain applications it is necessary to create statistical distributed inhomogeneities, e.g. to generate a bimodal distribution of grains. The **Match Solid Volume Fraction (SVF) Distribution** command allows to create such structures with an inhomogeneous solid volume distribution. Grains are shifted and rotated to optimally match a SVF distribution given by a Gaussian random field. This takes place *after* the generation step. The user should consider that:

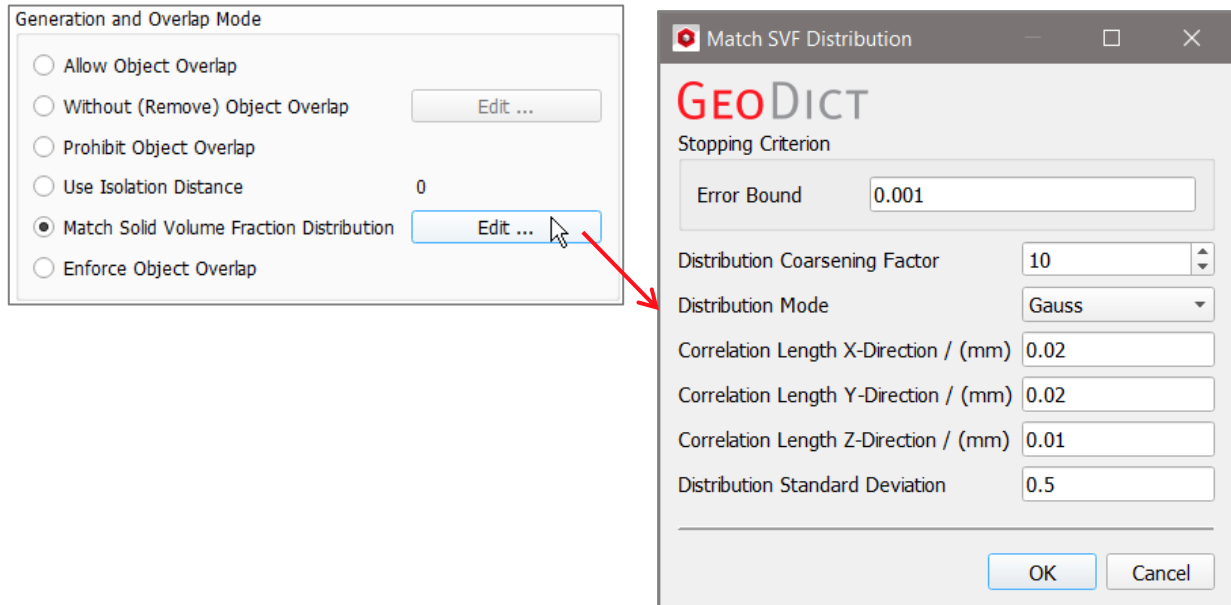

- Periodicity is checked automatically for all directions. This is a prerequisite for the **Match Solid Volume Fraction** algorithm.
- Using this feature, overlap cannot be removed during structure generation.
- As the SVF distribution is matched after generating the grains fitting the Stopping Criterion (see page [94](#)), the resulting values can differ from the inserted parameters for the Stopping Criterion. This is because the structure is generated with overlap and the amount of overlap can change when grains are shifted.
- The distribution for **Center** defined in the **Object Options** tab will also be affected strongly by matching the SVF distribution after generating the grain structure with the specified center distribution. The difference between the **Center Distribution** and the **Match SVF Distribution** is explained on page [20](#).
- It is recommended to generate the structure without inlet and outlet to use this algorithm. Otherwise, the objects will be also moved to these empty spaces. If desired, add inlet and outlet either with **GadGeo - Edit Domain** to avoid cropped objects (see the [GadGeo](#) handbook of this User Guide) or with **ProcessGeo - Embed** (see the [ProcessGeo](#) handbook of this User Guide).
- It is possible to reuse an existing stochastic field describing the desired SVF distribution. For this, first generate the structure with the mode **Allow Overlap** and then use the corresponding algorithm in **GadGeo**. Open the **GadGeo** section by selecting **Model** → **GadGeo** from the menu bar. Select **Algorithms** from the first pull-down menu and then **Match SVF Distribution** from the second. How to use this algorithm is described in the [GadGeo](#) handbook of this User Guide.

- For large structures, the feature needs a large amount of memory as a volume field is loaded in **GeoDict** additional to the structure file.

The SVF distribution can be controlled through the **Match SVF Distribution** dialog accessible via the **Edit ...** button.

In the **Match SVF Distribution** dialog, the following parameters can be set:

- **Stopping Criterion:** Define the **Error Bound** to determine when the SVF matching should be stopped. When the normalized relative change of solid volume fraction is smaller than the given error bound, the algorithm is stopped.
- **Distribution Coarsening Factor:** The SVF distribution is matched using a coarser version of the created Gaussian random field. The value must be small enough to resolve the heterogeneity of the structure. A larger value leads to a shorter run-time.

If the **Distribution Coarsening Factor** is set to 1, the Gaussian random field is generated with the same resolution as the grain structure.

For a grain structure with a domain size of 2048x1024x512 voxels and a voxel length of 1µm a coarsening factor of 32 leads to a random field of 64x32x16 voxels with a voxel length of 32µm.

To resolve the correlation length with a whole number of voxels, the value should be chosen as a divisor of the correlation length, which in turn is recommended to be a divisor of the domain size. For example, if the correlation length is set to 128 voxels and the coarsening factor is set to 32, $128/32 = 4$ voxels remain to resolve one feature of the random field.

- **Distribution Mode:** For distribution select **Gauss** or **Gradient** from the pull-down menu. The following parameters are different for these two options. It is recommended to select a divisor of the domain size in the corresponding direction. For a constant SVF in one direction choose the corresponding domain size as correlation length.

Gauss:

- **Correlation Length:** The correlation length is a measure for the inhomogeneity of the material. The parameters for **X-**, **Y-** and **Z-Direction** determine the correlation length of the Gaussian random field, which defines the SVF distribution.
- **Distribution Standard Deviation:** Define the relative standard deviation of the created SVF distribution. A larger value leads to a larger difference between the regions of low and high density.

Gradient:

- **Use Relative Position:** If checked, the left gradient column values from 0 to 1 correspond to locations in the structure.

In the Z-direction, the value 0 is at the origin and the value 1 is at end of the domain. If not checked the values in the left column correspond to absolute values in the given unit.

Distribution Mode		Gradient
<input checked="" type="checkbox"/> Use Relative Position		
	Relative Position in z-Direction	Density
1	0.1	2
2	1	10
Number of Rows		2
Load...		Save...

- **Distribution Gradient:** The right column assigns relative density values at the locations defined in the left column, e.g. the value 10 means that there are five times more objects at $Z = 1$ than at $Z = 0.1$, with a density value of 2. The object density increases and decreases smoothly between the given locations in the Z-direction.
- **Number of Rows:** The number of rows in the Distribution Gradient can be increased or decreased to enter as many pairs of position and density as desired.
- **Load/Save:** The Distribution Gradient can be saved to and loaded from a .txt file.

In the following example, grains are generated in a domain of $600 \times 600 \times 50 \mu\text{m}$.

For the upper structure, **Allow Object Overlap** is checked and no SVF distribution is matched.

The bottom structure was generated with the same parameters, except for matching the SVF distribution shown below.

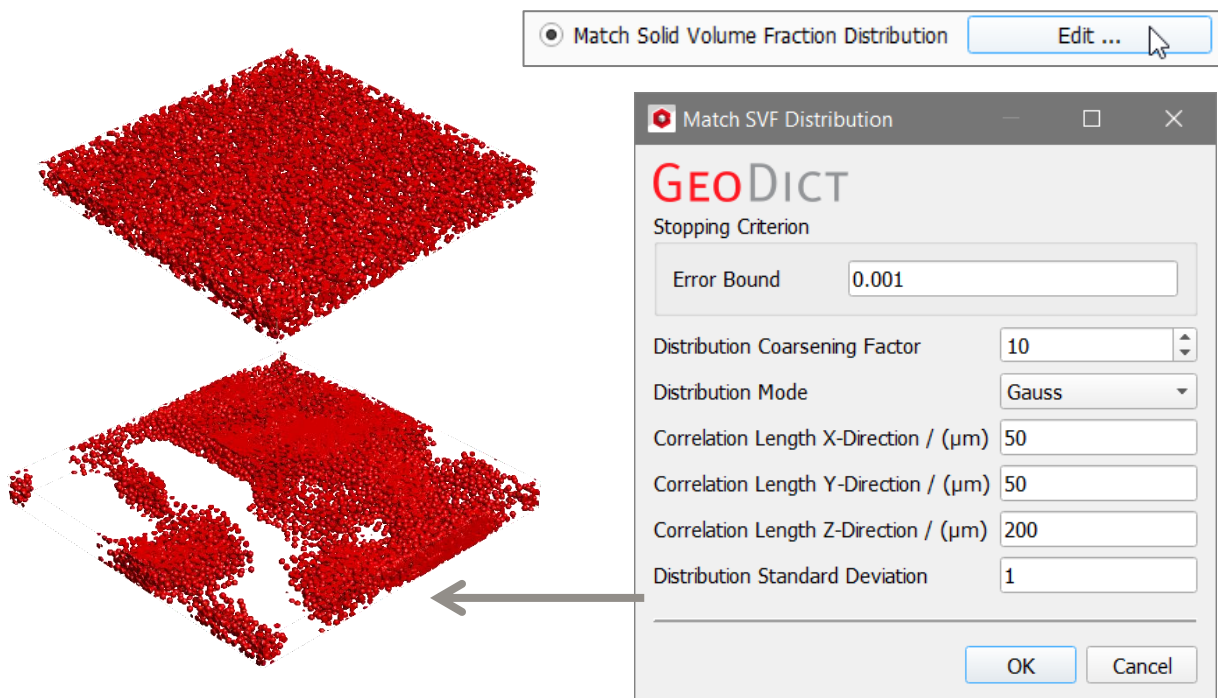

After generating a structure matching a SVF distribution in the result folder a volume field describing the used gaussian random field is saved.

Select **File** → **Load Volume Field ...** from the menu bar to load it or choose the **Data Visualization** tab in the **Result Viewer** of the (*.gdr) result file and click **Load *.gvf**.

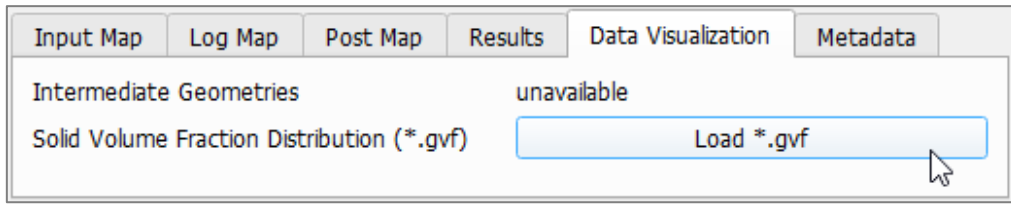

For the example from above, the resulting gaussian random field is shown below in 2D view from all three directions.

Viewed from X-direction a high correlation in Z-direction can be observed, as the structure size in this direction equals the **Correlation Length Z**. In Y-direction a more inhomogeneous SVF distribution was generated, as the structure size in Y-direction is 12 times higher than the **Correlation Length Y**.

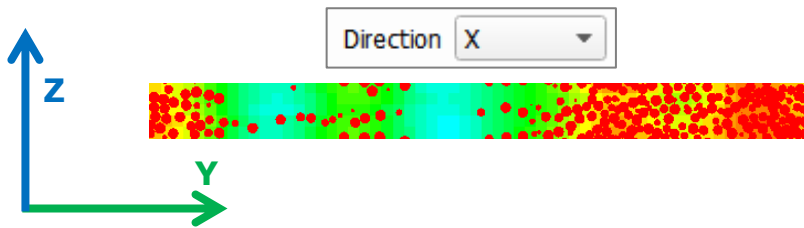

Viewed from Y-direction a similar observation can be obtained. Still the distribution in Z-direction is very homogeneous, whereas it has low correlation in X-direction.

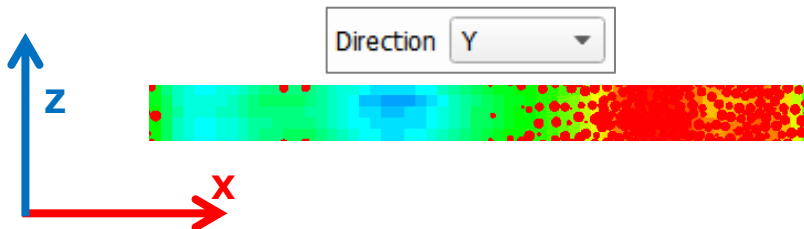

Viewed from Z-direction the structure is very inhomogeneous, due to small **Correlation Length** values for **X** and **Y** (50µm) compared to the structure size in these directions (600µm).

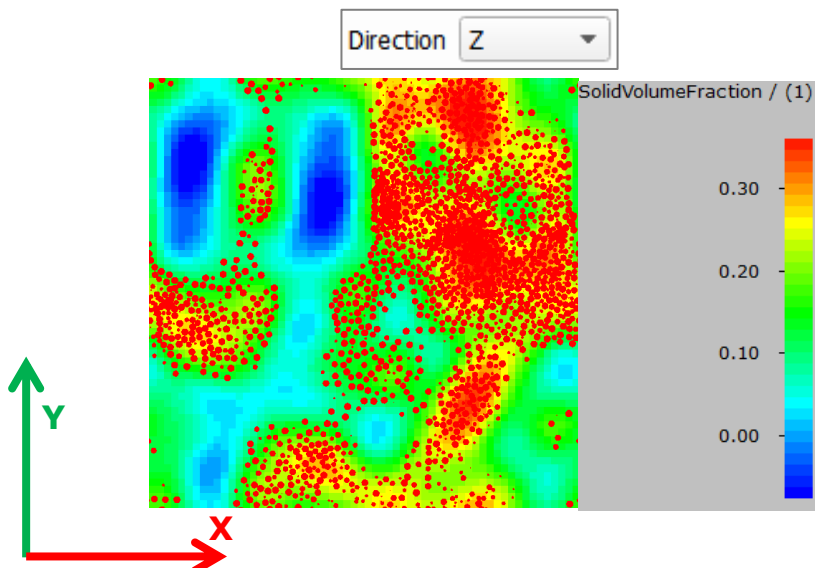

In the following example observe how the objects are distributed corresponding to the given **Gradient**.

The objects in the first example have the highest density in the center of the Z-axis. Towards both ends of the domain in Z-direction the objects become fewer. This displays the Density values 0 for the relative positions Z=0 and Z=1 and a density of 1 for the relative position Z=0.5.

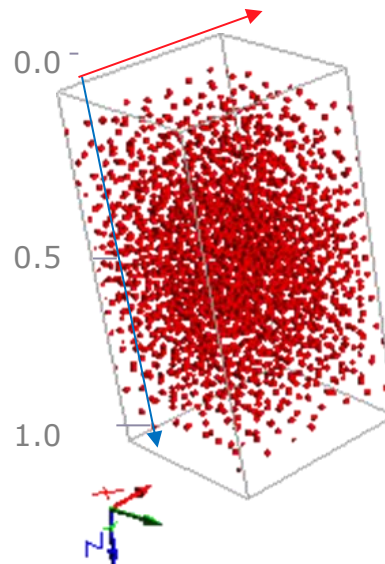
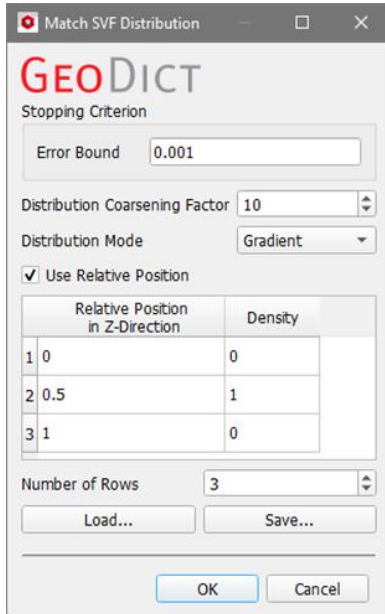

The second example shows a density distribution in Z-direction with 4 rows. A density of 20 for position Z=0 leads to twice as many objects near the top as objects in the lower third with a density value of 10 for position Z=0.7. Towards the center and the bottom, the objects become fewer for a density value of 0.

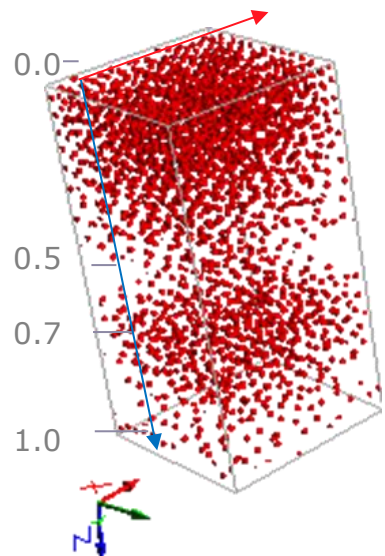
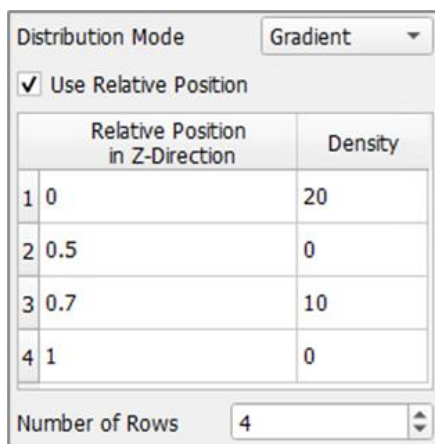

This feature is different from the **Density Distribution for Center**, to be found in the **Object Options** (see page 26). The Match SVF Distribution is a post-processing step, and the grains are moved till they match the given solid volume fraction distribution.

For the Center Distribution, the object centers are placed according to the given distribution which is much faster and does not change the orientation of the objects, but leads to a different solid volume fraction distribution and the distribution is not as smooth as with **Match SVF Distribution**.

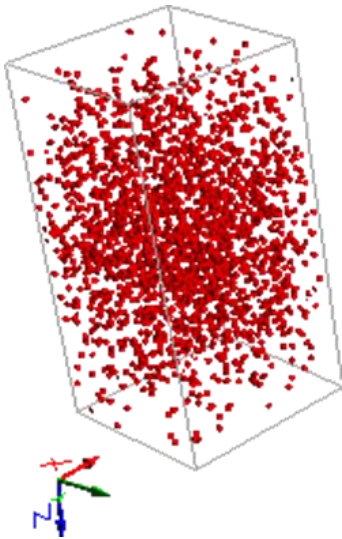

Center Distribution

Use Relative Position		
	Relative Position in Z-Direction	Density
1	0	0
2	0.5	1
3	1	0

Number of Rows: 3

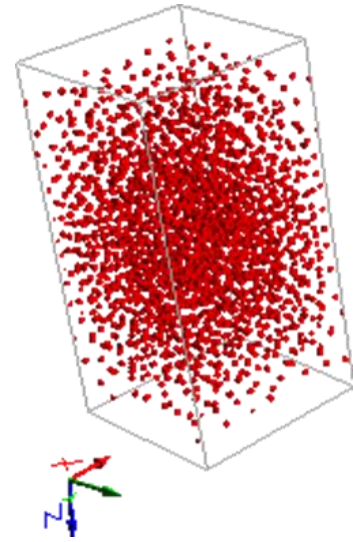

SVF Distribution

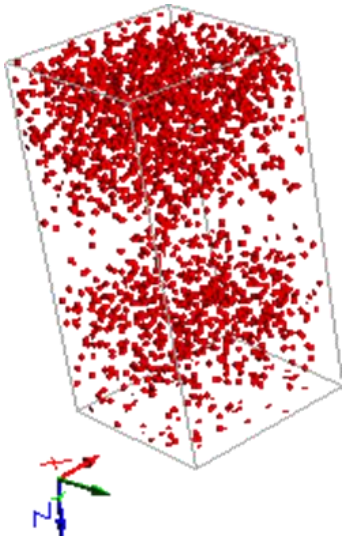

Use Relative Position		
	Relative Position in Z-Direction	Density
1	0	20
2	0.5	0
3	0.7	10
4	1	0

Number of Rows: 4

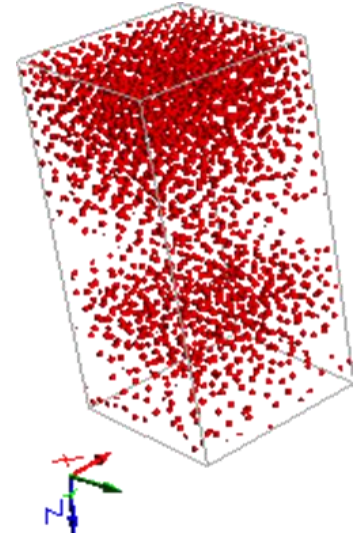

Enforce Object Overlap

The structures objects are required to join each other, forming a large, connected component. This effect is obvious when the structures solid volume percentage is low (here 10%), i.e. the objects do not already form a connected component.

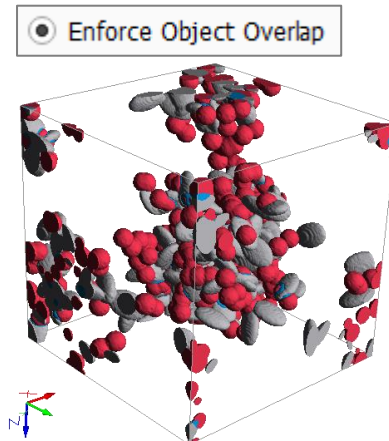
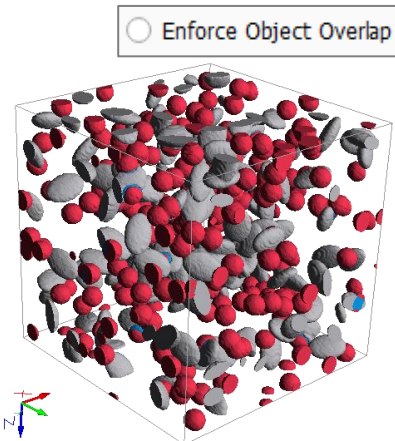

STOPPING CRITERION

The parameters in the **Stopping Criterion** panel of the **GrainGeo Create Options** dialog define the stop criteria. The available parameters are **Fixed Object Number**, **Solid Volume Percentage (%)**, **Grammage (g/m²)**, **Density (g/cm³)** or **Object Weight Percentage (%)**. Additionally, when the **Maximal Run Time (h)** is expired, the process is stopped even when the desired stopping criterion cannot be achieved.

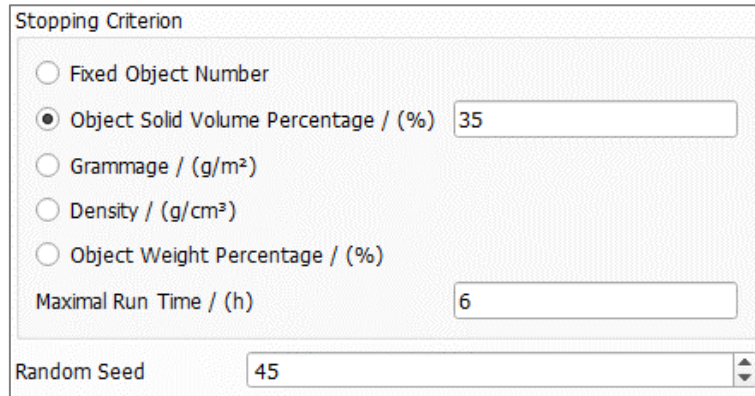

When **Grammage**, **Density** or **Object Weight Percentage** are chosen as stopping criterion, the temperature must be set as additional parameter. The density of the constituent materials will be set with respect to the chosen temperature based on the **Material Database**

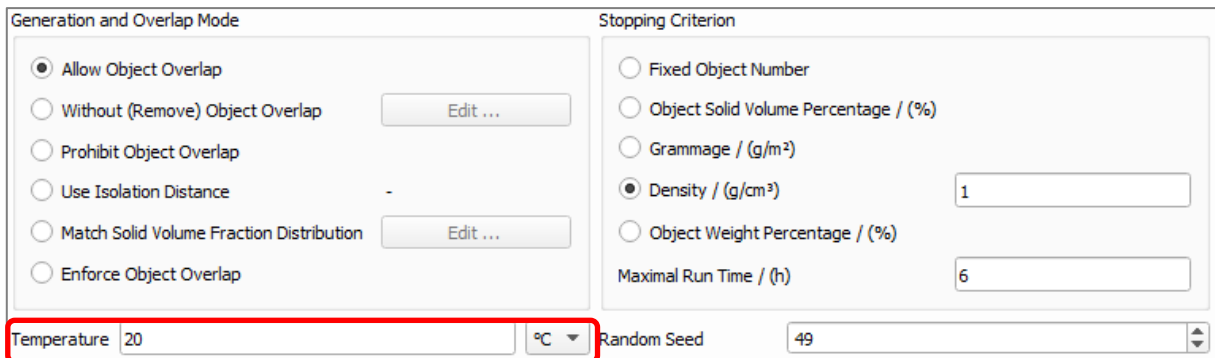

When choosing **Fixed Object Number** or **Solid Volume Percentage**, the **Temperature** parameter is not available.

Fixed Object Number

When **Fixed Object Number** is chosen as stopping criterion, GrainGeo places the given number of objects in the structure and then the generation stops.

Observe the effect of setting a fixed number of objects (10, 100, or 200) as stopping criterion, for the generation of a structure with two types of spheres. All other parameters are left untouched.

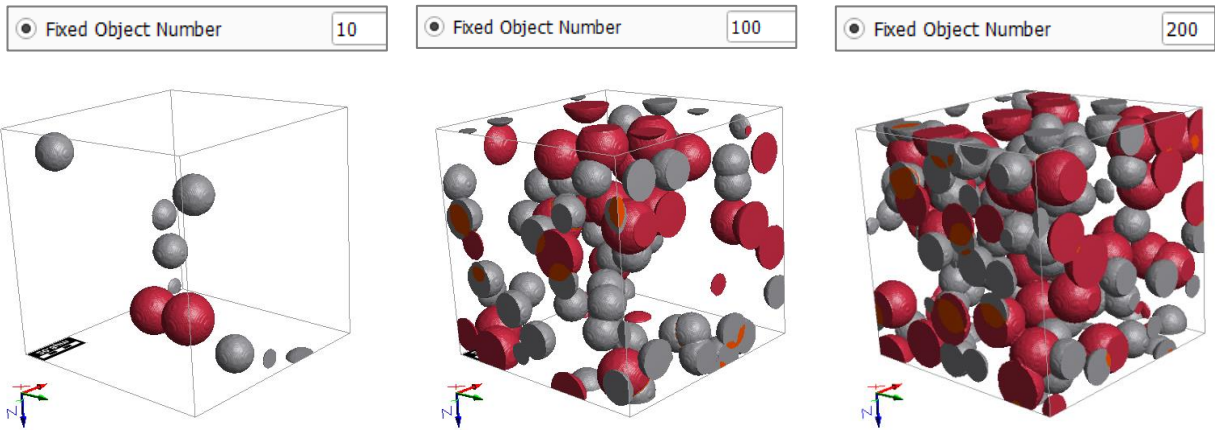

Object Solid Volume Percentage

Object Solid Volume Percentage (SVP) determines the fraction of the total volume in percent that the structure should have. Accepted values range from 0 to 100%. For example, a structure with an **Object Solid Volume Percentage** of 40 consists of 40% spheres and 60% void space. Porosity is defined as $(1 - \text{SVP}/100)$. Observe the difference in a structure when varying the solid volume percentage from 5%, to 20% and finally to 40%, while all other parameters are left unchanged.

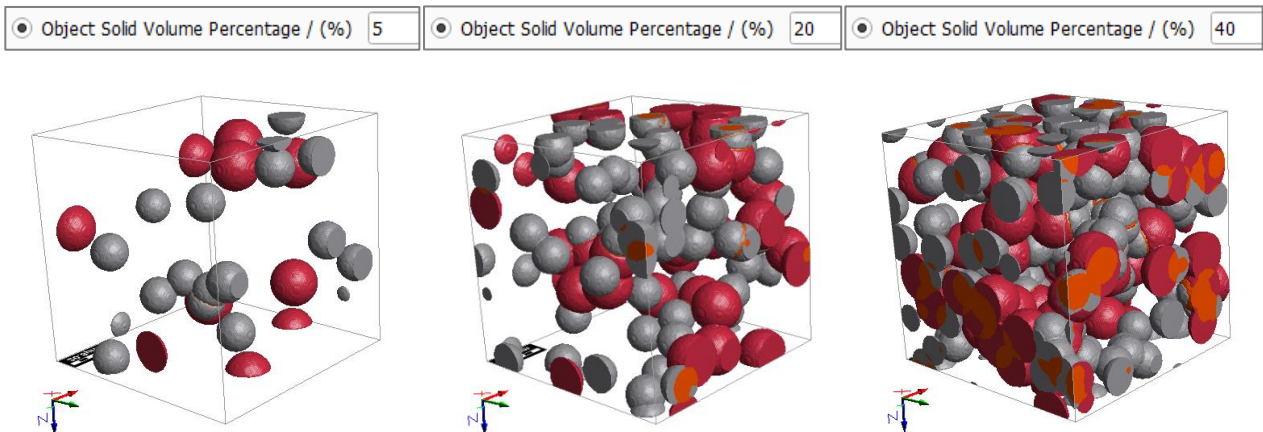

Grammage

The **Grammage** (g/m^2) determines the mass per unit area (in the XY-Plane) of the resulting structure. When **Grammage** is chosen as stopping criterion, the **Density** (g/cm^3) of the object material(s) must be defined for each object type and chosen material in the object panels under the **Object options** tab and the temperature must be set in the **GrainGeo Create Options** dialog.

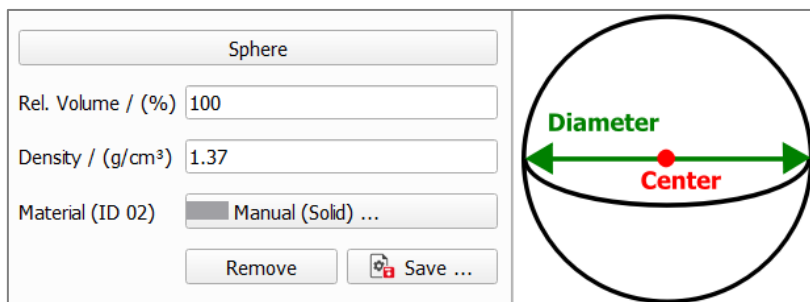

Observe the effect of increasing the **Grammage** from 60 g/m² to 120 g/m², whereas all other parameters are left unchanged.

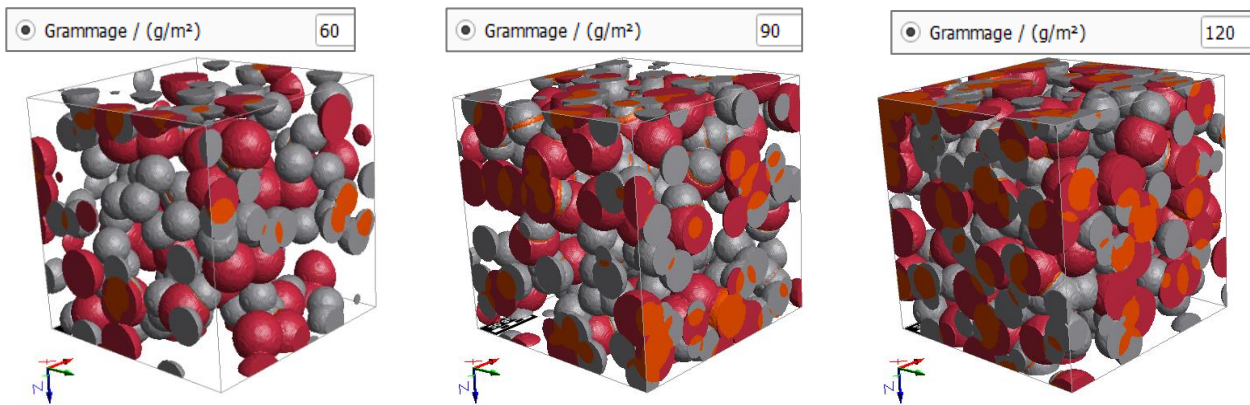

Density

The **Density** (g/cm³) of the resulting structure depends on the densities of the constituent materials. In the following simple example, the **Matrix Density** is 0 (for vacuum), and the two grain types have the densities 3.1 g/cm³ and 1.0 g/cm³. The **Density** of the structure is set to 0.10 g/cm³ and to 0.25 g/cm³. It cannot be set smaller than the lowest occurring density (here 0 g/cm³) or larger than the highest occurring density (here 3.1 g/cm³).

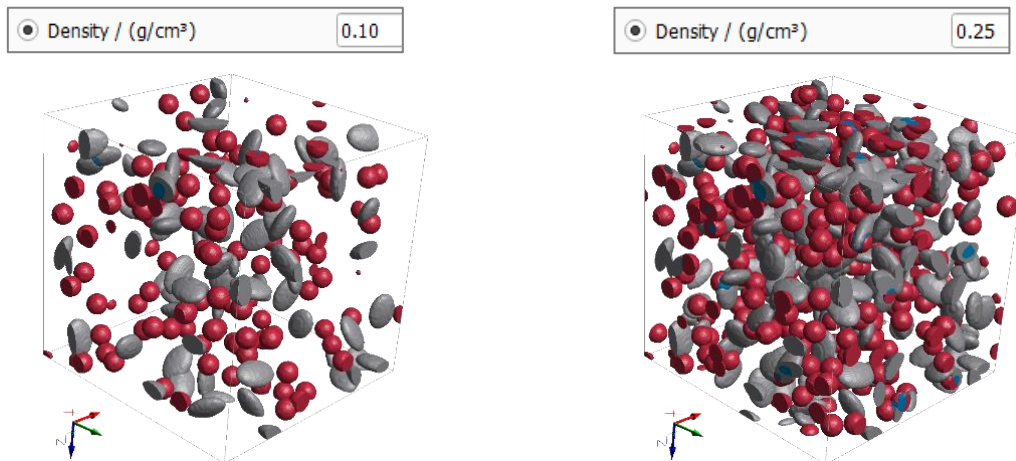

Object Weight Percentage

The **Object Weight Percentage** determines the weight of the created object in relation to the weight of the whole structure (including the pore material). The calculation is only possible when the density of the **Pore / Matrix Material** is greater than zero. Otherwise, an error message will appear.

The relationship of the values **Fixed Object Number**, **Object Solid Volume Percentage**, **Grammage**, and **Density** can be observed in the Result Viewer under the Results tab. If the density of the Pore / Matrix Material is greater than zero, also the **Object Weight Percentage** appears under the Results tab.

In this example, a **Density** of about 0.10 g/cm³ corresponds to a **Fixed Object Number** of 219, a **SVP** of 3.88% and a **Grammage** of 20.04%.

Absolute object distribution:

	Count	Volume / (%)	Grammage / (g/ m ²)	Density / (g/ cm ³)	Weight / (%)
Total	realized: 215 target: --- error: ---	realized: 3.87 target: --- error: ---	realized: 19.98 target: --- error: ---	realized: 0.0999 target: 0.1000 error: -0.0001	realized: 0.00 target: --- error: ---
Object type 1	realized: 215 target: --- error: ---	realized: 3.87 target: --- error: ---	realized: 19.98 target: --- error: ---	realized: 0.0999 target: --- error: ---	realized: 0.00 target: --- error: ---

Maximal Run Time

The **Maximal Run Time** (h) becomes important when generating complex structures with elevated solid volume fraction. When **Prohibit Objects Overlap** has been checked, the required number of objects in the structure may become unattainable. In that case, the structure generation is stopped after the time entered in **Maximal Run Time** has passed and the achieved structure is considered as the result. The analysis of the GDR result file shows any disparity between the achieved result values and the desired ones.

RANDOM SEED

Random Seed initializes the random number generator behind the structure generator. Changing its value produces different sequences of random numbers and hence, different realizations of the specified structure. If all settings are equal, generating with the same **Random Seed** value produces the identical structure. **Random Seed** must be a non-negative integer number.

Varying the **Random Seed** allows generating different samples of the same granular structure. In the following examples, all parameters are unchanged while the Random Seed automatically increases with every generation run (54, 55, 56).

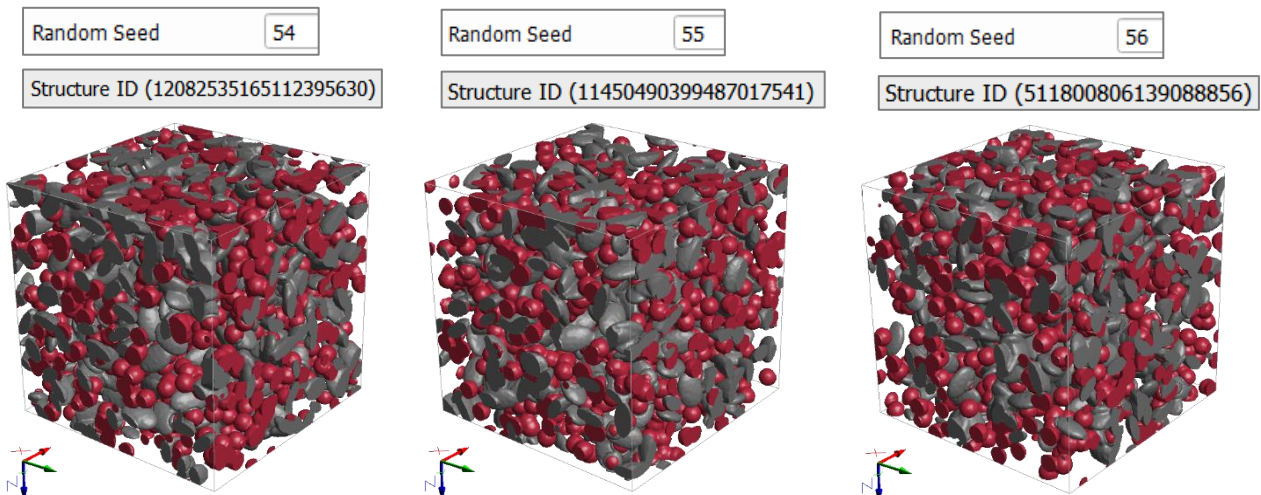

OBJECT OPTIONS

The objects available for the generation are organized and listed in panels. Up to eight different object types may be added to the same structure.

For all objects, the left column of the panel contains the **Object Type** name, the object percentage in the structure as **Count**, **Volume**, or **Weight**, and the object **Material**.

The middle column shows a drawing of the main geometrical characteristics of this object type. In the right column, the geometrical properties or defining parameters of the objects can be entered. These geometrical parameters include **Diameter**, **Orientation**, **Length**, **Position**, **Enclosing Object**, **Number of Points**, etc.

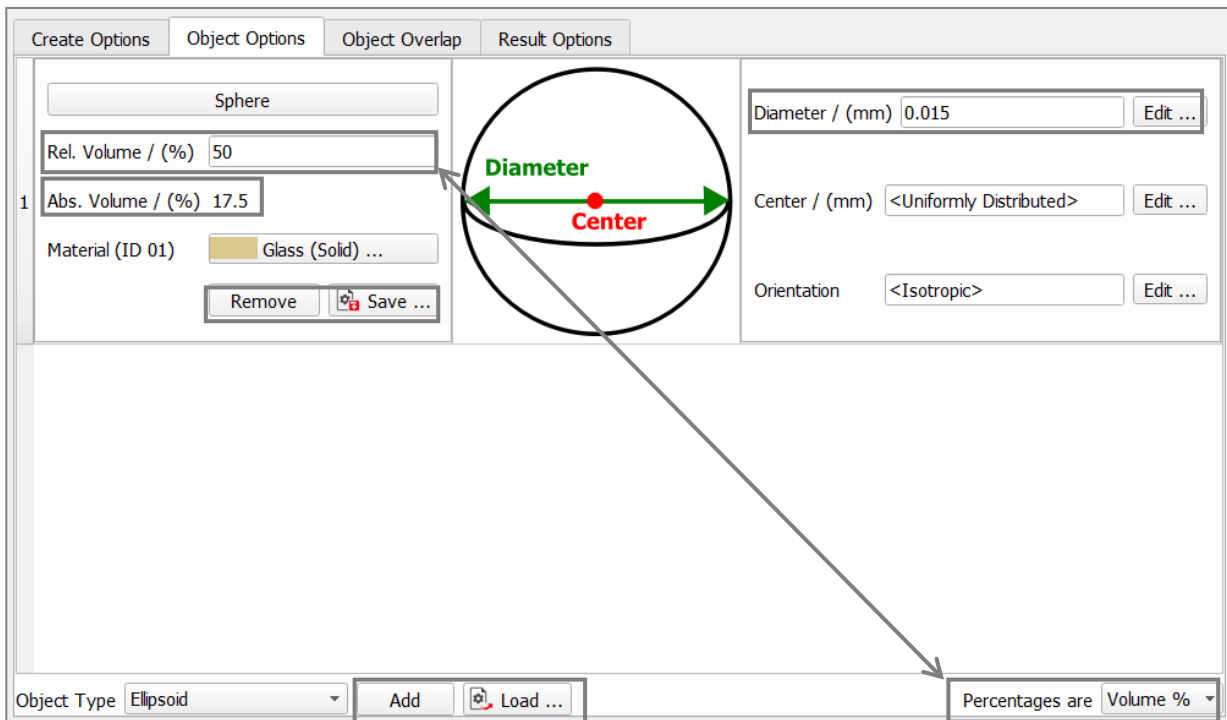

Sphere and Ellipsoid are the default **Object Types**. At the bottom left of the dialog, clicking **Add** inserts other object types chosen from the **Object Type** pull-down menu. Previously saved objects with individually defined parameters can be loaded via the **Load...** button. Object types can be discarded again when clicking **Remove** in the left panel or can be saved as predefined object using the **Save...** button.

Clicking on the object type name minimizes the object panel, and clicking on it again when minimized, expands it again. A scroll bar at the right allows to navigate up and down in the list of chosen object types.

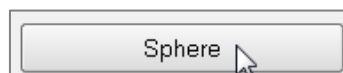

OBJECT TYPE PERCENTAGE AS COUNT, VOLUME, OR WEIGHT

The object type percentage can be specified as **Count %**, **Volume %** and **Weight %** as selected from the pull-down menu at the bottom right of the dialog.

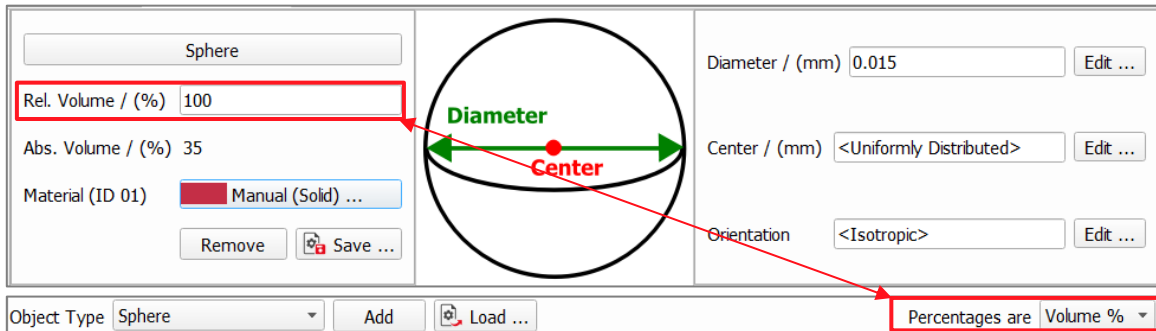

Note that, if the **Weight** option is chosen, the material density must be provided (or it is taken from the **GeoDict** material database) even when **Grammage** is not selected under the **Create Options** tab.

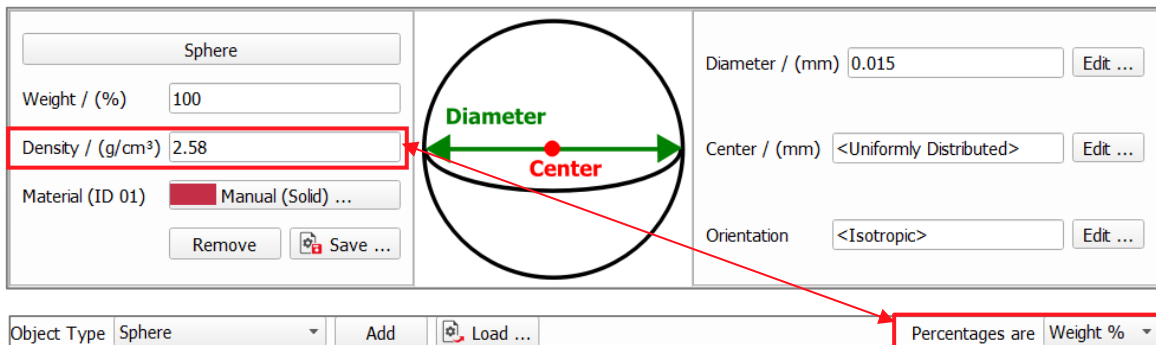

MATERIAL

Material designates the constituent material assigned to the object type used in the granular structure. The pull-down menu gives access to selecting the desired material from the **GeoDict Material Database**. When none of the materials available in the database fit the preferred specifications, **Manual** should be chosen. Alternatively, a new material with the desired specifications can be added to the **Material Database** (see the [Material Database](#) handbook of this User Guide)

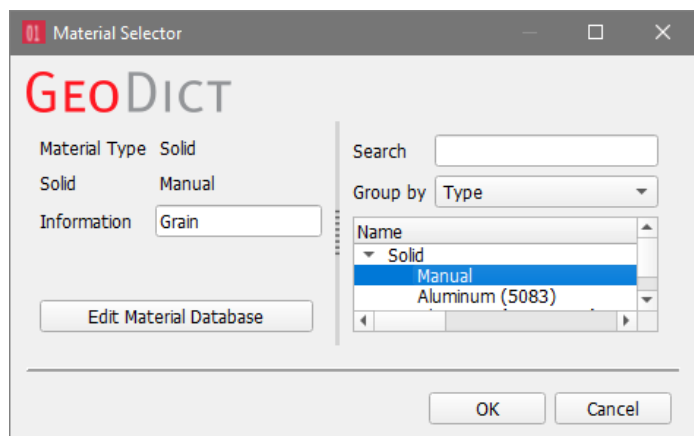
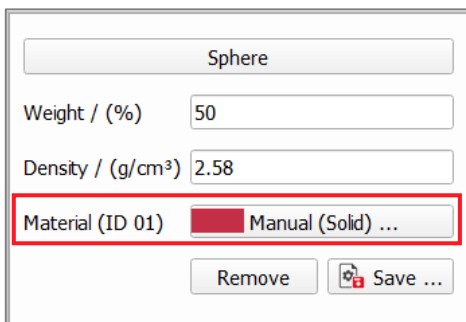

To match realistic material colors for visualization in a certain application, the default **Material** colors can be changed through **Settings** → **Color & Visibility Settings** in



the menu bar. For more visualization options, see the [Visualization](#) handbook of this User Guide.

OBJECT TYPES

The **Object Type** is selected from the pull-down menu or can be loaded via the **Load...** button at the lower left of the **Object Options** tab in the **GrainGeo Create Options** dialog.

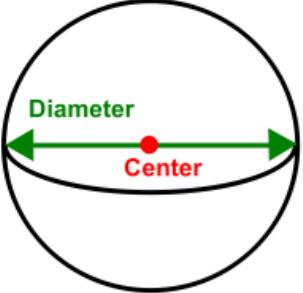
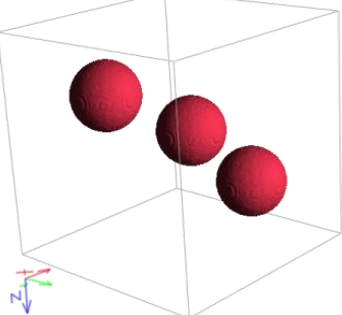
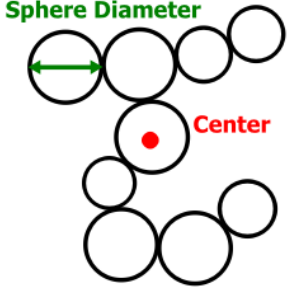
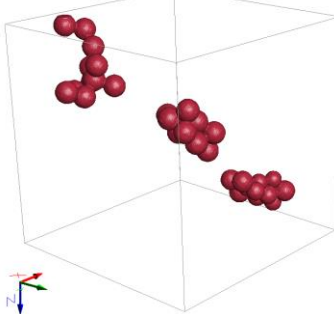
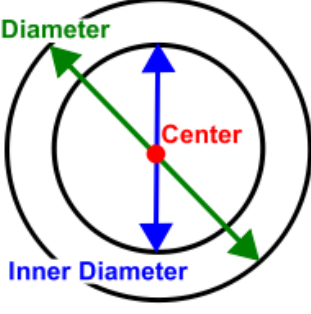

The following table summarizes the object types that can be used with **GrainGeo Create** and **Pile** commands: **Sphere**, **Hollow Sphere**, **Ellipsoid**, **Superquadric Particle**, **Box**, **Planar Polyhedron**, **Convex Polyhedron**, **Pyramid**, **Short Fibers** (**Circular**, **Hollow**, **Rosetta**, **Elliptical**, **Cellulose**, **Rectangular**, and **Angular**), and their combinations (**Combined Objects**).

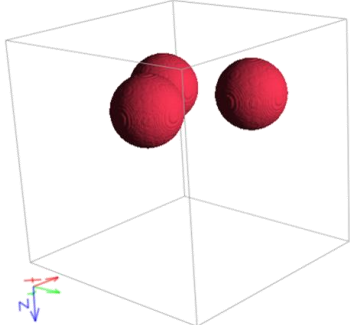
Defining parameters	Object type and examples	
	<p>Sphere</p>	
	<p>Sphere Agglomerate</p>	
	<p>Hollow Sphere</p> 	

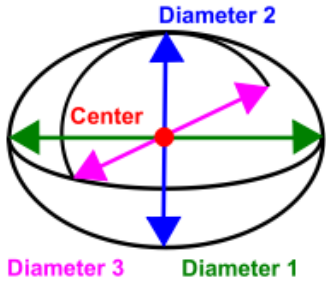
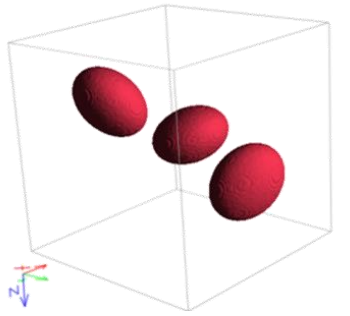
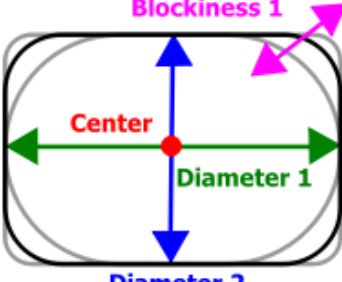
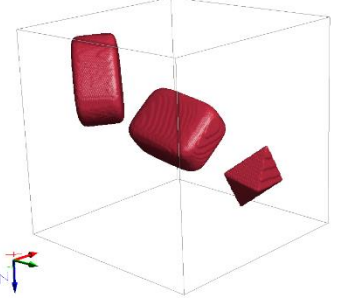
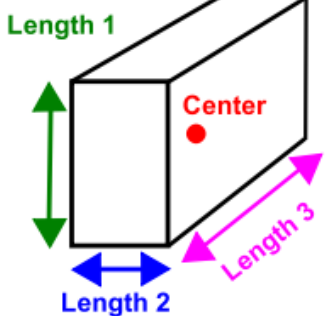
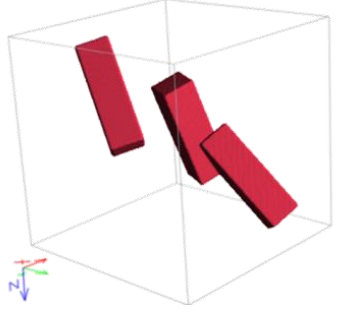
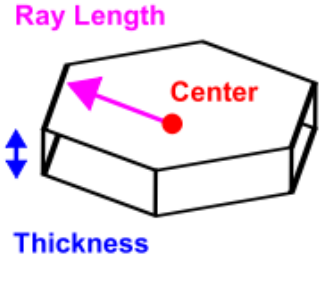
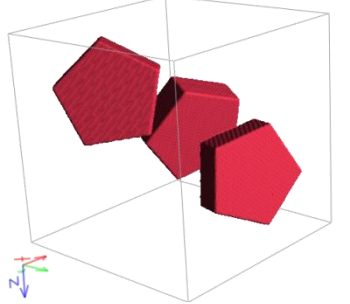
 <p>Diameter 2 Center Diameter 3 Diameter 1</p>	<p>Ellipsoid</p>	
 <p>Blockiness 1 Center Diameter 1 Diameter 2</p>	<p>Superquadric particle</p>	
 <p>Length 1 Center Length 2 Length 3</p>	<p>Box</p>	
 <p>Ray Length Center Thickness</p>	<p>Planar Polyhedron</p>	

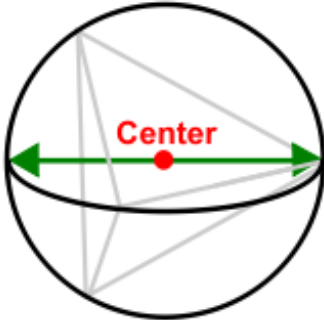
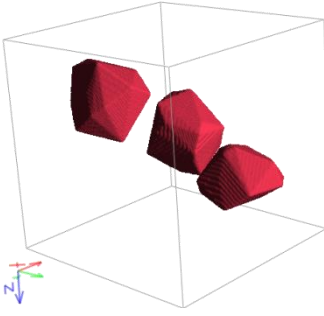
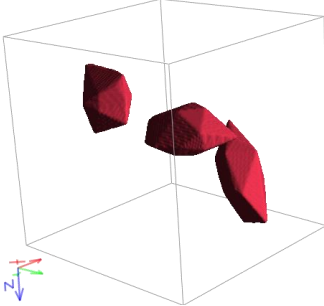
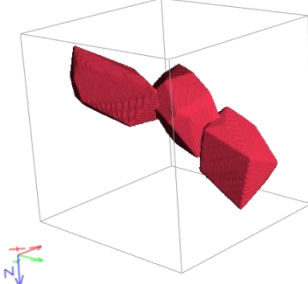
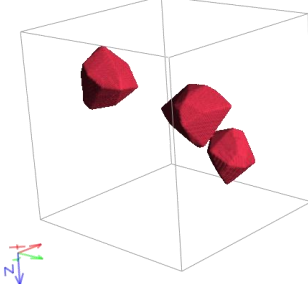
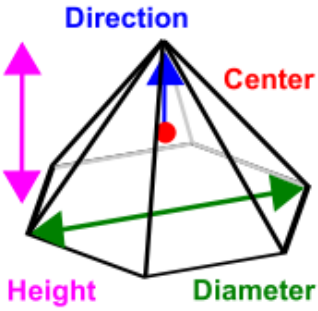
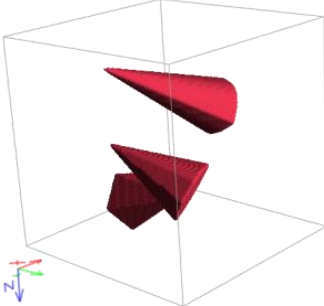
 <p>Enclosing Diameter</p>	<p>Convex Polyhedron Enclosing Object: Sphere</p>	
	<p>Convex Polyhedron Enclosing Object: Ellipsoid</p>	
	<p>Convex Polyhedron Enclosing Object: Box</p>	
	<p>Convex Polyhedron Enclosing Object: Pyramid</p>	
	<p>Pyramid</p>	

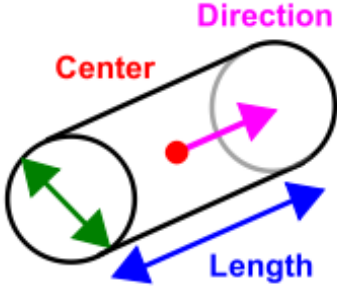
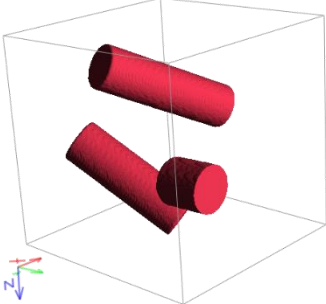
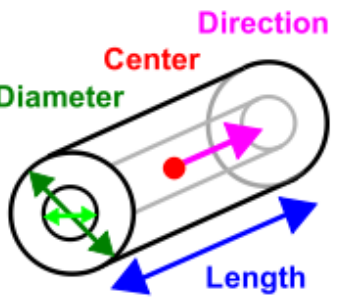
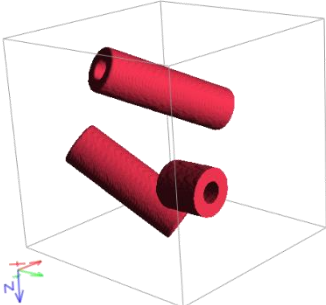
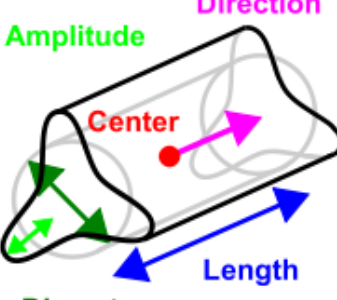
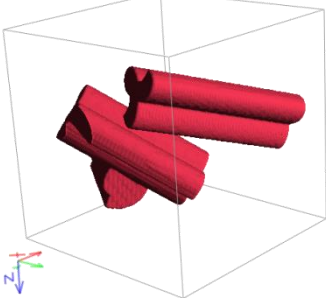
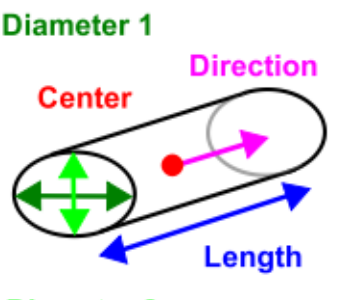
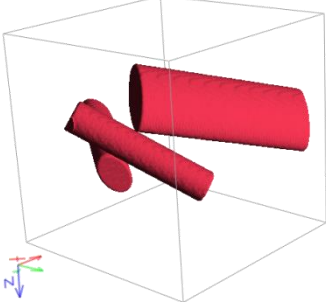
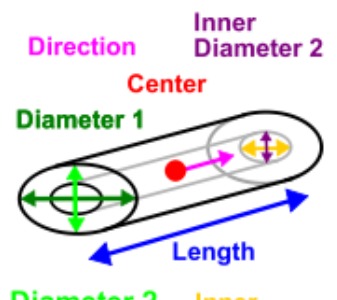
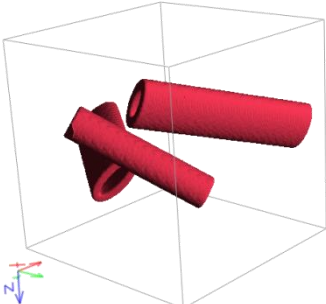
 <p>Diameter</p> <p>Length</p> <p>Center</p> <p>Direction</p>	<p>Short Circular Fiber</p>	
 <p>Inner Diameter</p> <p>Length</p> <p>Center</p> <p>Direction</p>	<p>Short Hollow Fiber</p>	
 <p>Amplitude</p> <p>Length</p> <p>Center</p> <p>Direction</p>	<p>Short Rosetta Fiber</p>	
 <p>Diameter 1</p> <p>Diameter 2</p> <p>Length</p> <p>Center</p> <p>Direction</p>	<p>Short Elliptical Fiber</p>	
 <p>Diameter 1</p> <p>Diameter 2</p> <p>Inner Diameter 1</p> <p>Inner Diameter 2</p> <p>Length</p> <p>Center</p> <p>Direction</p>	<p>Short Cellulose Fiber</p>	

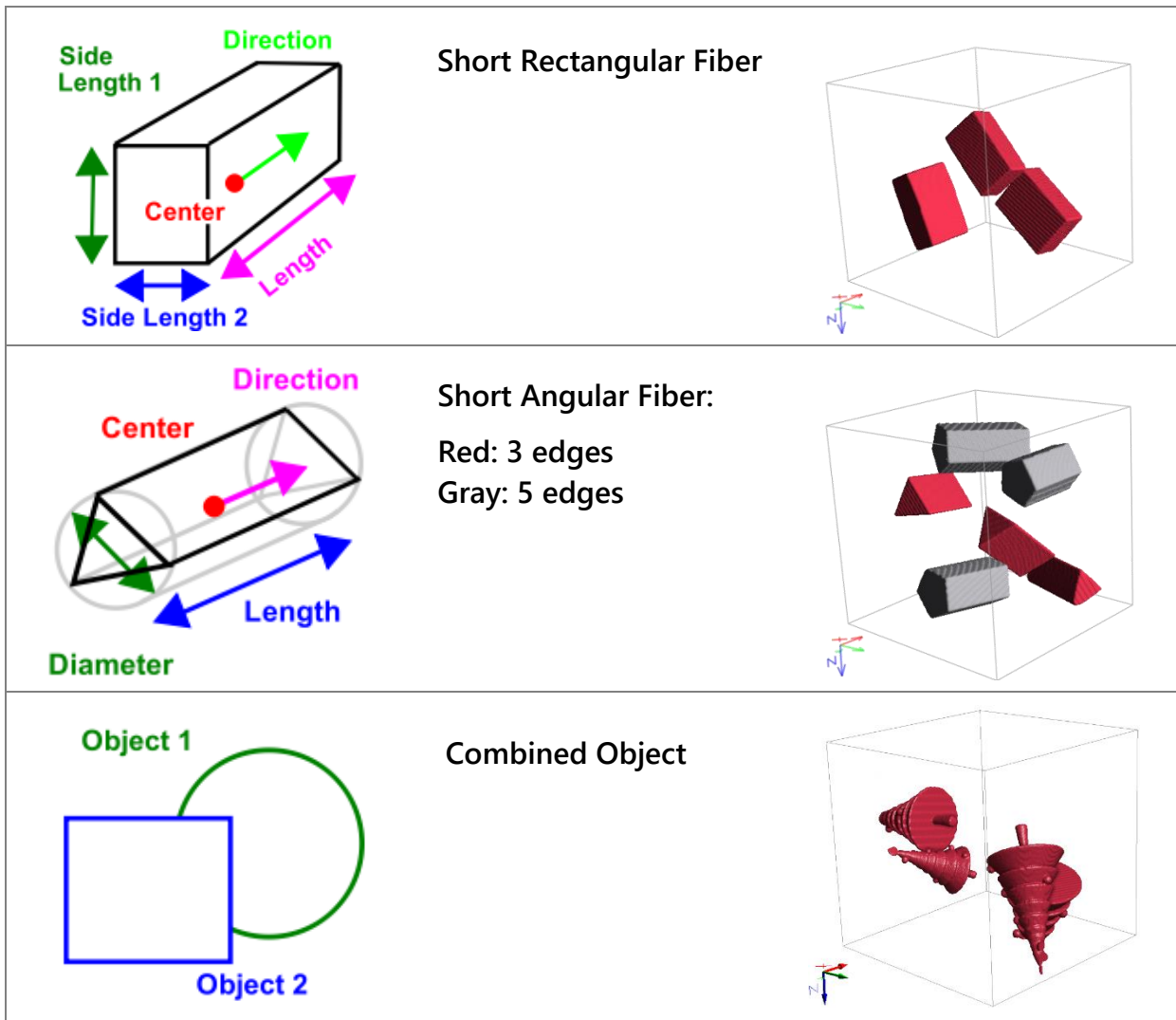

OBJECT PARAMETERS

The right column of the **Object Type** panel contains the parameters controlling the geometrical and physical properties of each object type of the granular structure.

Some object parameters can only be set for specific object types, e.g. **Number of Edges**, and **Ray Length** are only applicable for planar polyhedrons. Other parameters are common to several objects, such as e.g. **Diameter**, **Center**, **Length**, or **Orientation**.

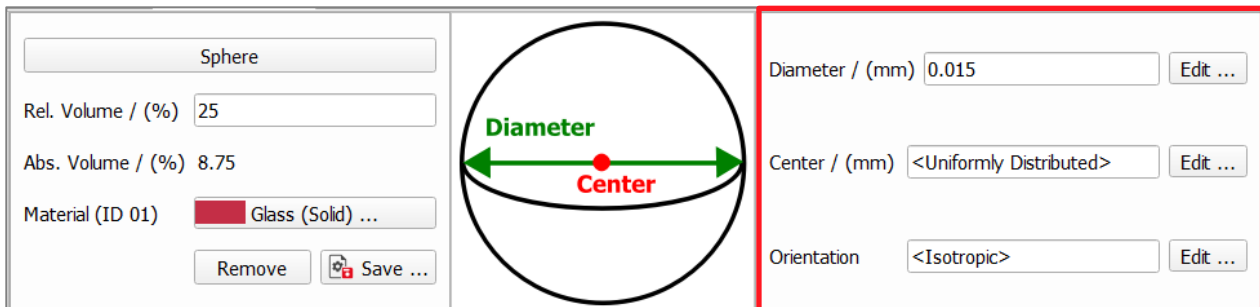

The defining parameters can be edited in the dialogs which open when clicking the corresponding **Edit ...** buttons.

The **Diameter** and the **Enclosing Object Diameter**, but also the **Ray Length**, the **Side Length**, the **Wall Thickness**, the **Height**, and the **Scaling Factor** (for Combined Objects) can be set to a **Constant** value, or to follow a distribution (**Uniformly in interval**, **Gaussian**, **Probability Distribution** (user-defined), or **Log-Normal**).

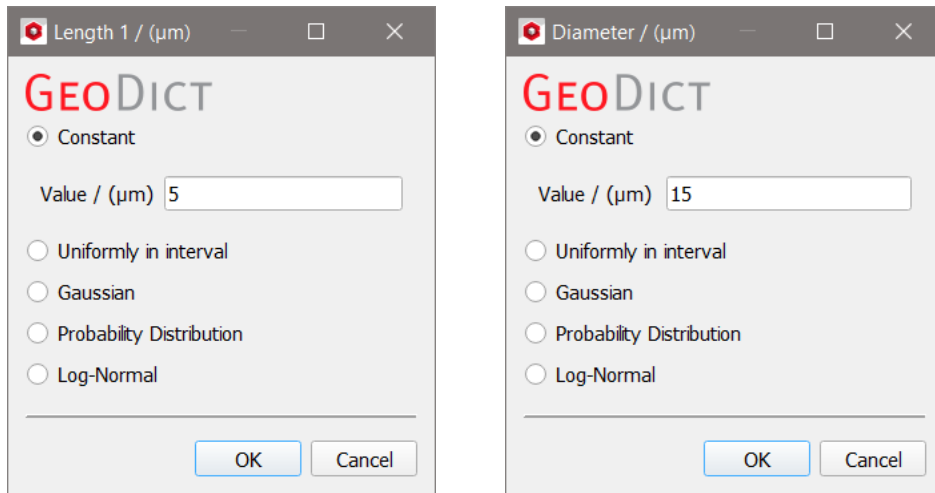

The **Number of Edges** (for Planar Polyhedrons) and the **Number of Random Points** (for Convex Polyhedrons) values also set to be **Constant**, to distribute **Uniformly in interval**, or to follow a **Gaussian** or user-defined **Probability Distribution**.

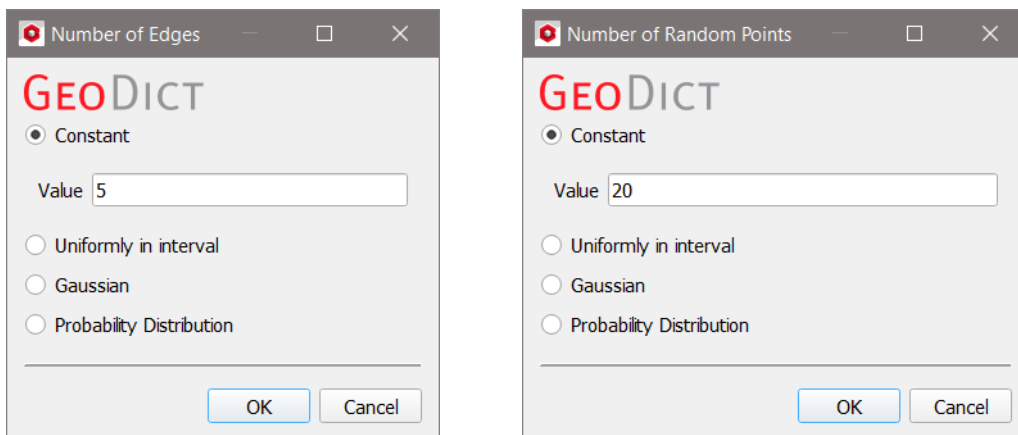

Finally, the **Center** value can be set to distribute **Uniformly**, **On Current Objects**, **Uniformly in Box**, or follow a user-defined **Density Distribution**. These distributions are explained in detail below (see pages [59ff.](#), **Object Parameters** → **Center**).

The option to center **On Current Objects** is only present when the user has checked **Create in Current Domain** (see page [5](#)).

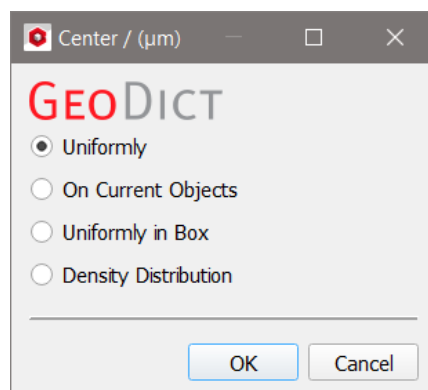

Diameter

Observe the effect that the **Diameter** options (as shown in the dialogs) have on the generated granular structure made of spheres.

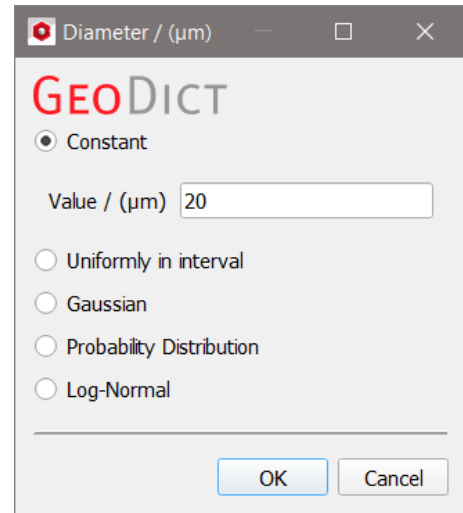
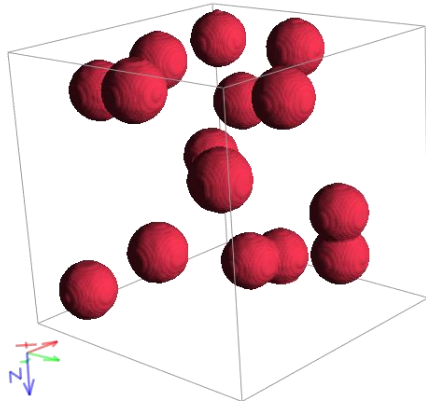

For **Sphere Agglomerates** the **Sphere Diameter** can also be different for the spheres belonging to the same agglomerate.

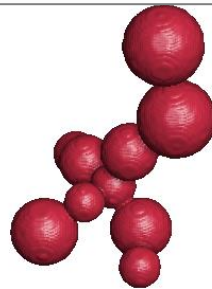

Uniformly in Interval

When selecting **Uniformly in interval**, and entering a **Minimum** value and a **Maximum** value, the range of the respective parameter is uniformly distributed within the given interval.

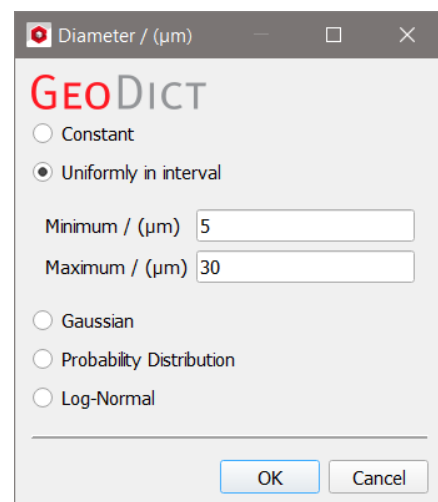
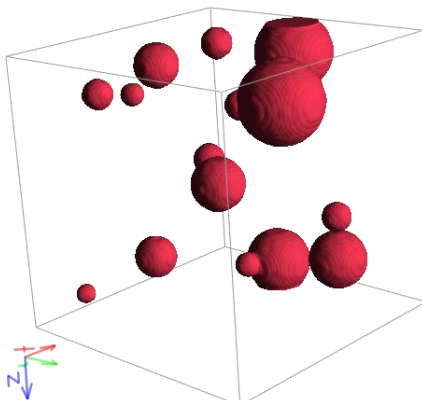

Gaussian

Taking the **Gaussian** (or **normal**) distribution, the random diameter, enclosing object diameter, ray length, side length, thickness, height, or scaling factor values follow a bell-shaped distribution. The diameter and length values cluster around the entered **Mean Value** but may vary according to the entered **Standard Deviation**.

The value in **Distribution Bound** corresponds to the interval on both sides of the mean value limiting the random diameter or angle values that are accepted. For diameters, a **Distribution Bound** value of 10 μm means that the diameter values may vary only -10 μm to +10 μm from the given **Mean Value**. The parameters must be set so that no negative values are possible. For example, a diameter mean value of 20 μm and a distribution bound of 25 μm would lead to an error message appearing, as the diameter could reach a value less than zero.

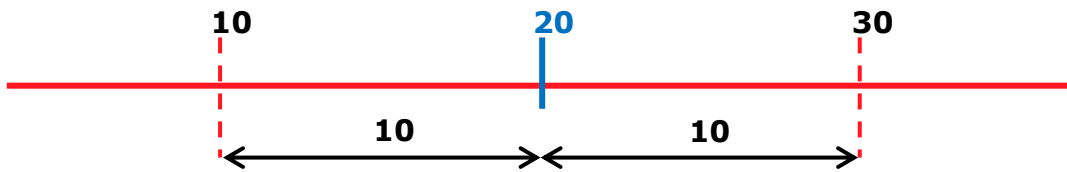

For all distribution options (Gaussian, Probability Distribution and Log-Normal) on the right of the dialog the distribution is visualized in a 2D plot.

The **red** line plots the **Diameter Percentage Distribution** defined by Mean Value, Standard Deviation and Distribution Width. It displays how much objects of which diameter will be generated in percent.

The **blue** curve visualizes the cumulative diameter distribution.

The three **dashed blue** lines show the diameter values for the 10% percentile, the 50% percentile and the 90% percentile of the distribution. On average, 10% of the objects have a diameter smaller than the 10% percentile value, and 90% of the generated objects have a diameter higher than that value. For further explanations, see the [Wikipedia](#) article.

Right-clicking to the plot opens a dialog to **save** the plot or to **Edit** the **Axis Settings**. Checking or unchecking the checkboxes next to the graph names decides which curves should be displayed. More information about these options can be found in the [Result Viewer](#) handbook of this User Guide.

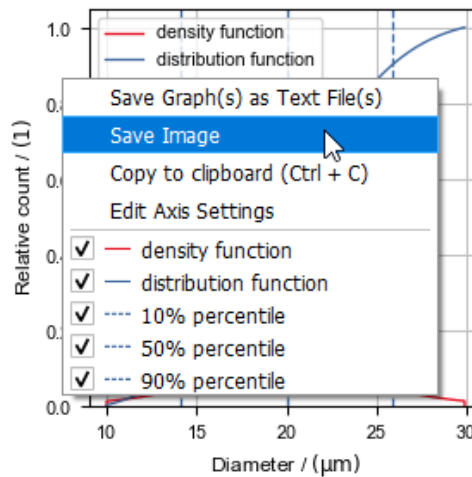

If **Cut-Off Distribution** is checked, the distribution is truncated at the bounds. This means that all values outside the bounds are dropped and not considered for generation. If this option is not checked, then all values that are outside of the bounds are set to be on the distribution bound. Not checking this option leads to an accumulation of values on the bounds.

In the example below, leaving **Cut-Off Distribution** unchecked leads to many grains with diameters of 40 and 60 µm.

In contrast, checking **Cut-Off Distribution** leads to more grains with diameter between 40 and 60 µm.

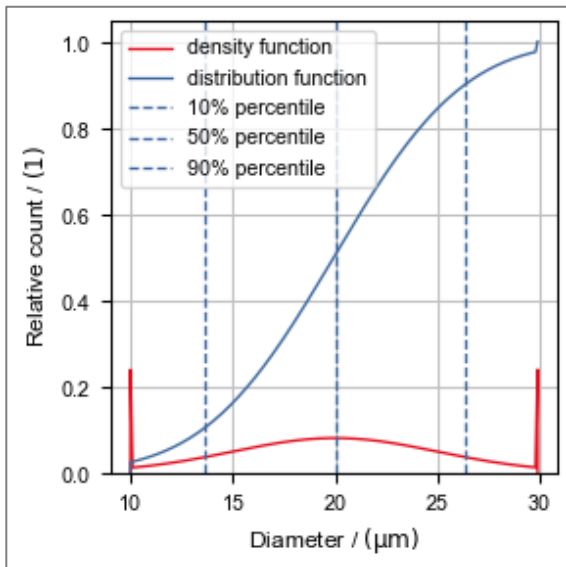

Cut-Off Distribution

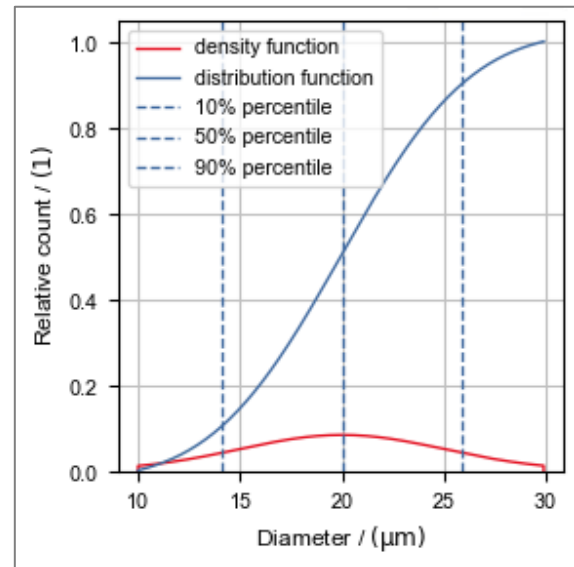

Cut-Off Distribution

More details on Gaussian distributions can be found e.g. on the [Wikipedia](#) page on Normal (or Gaussian) distributions.

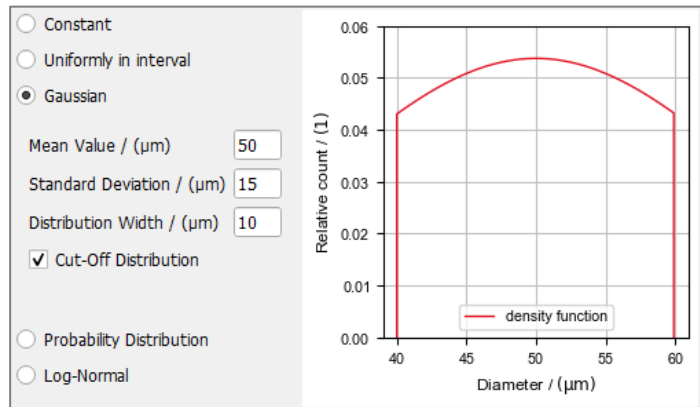
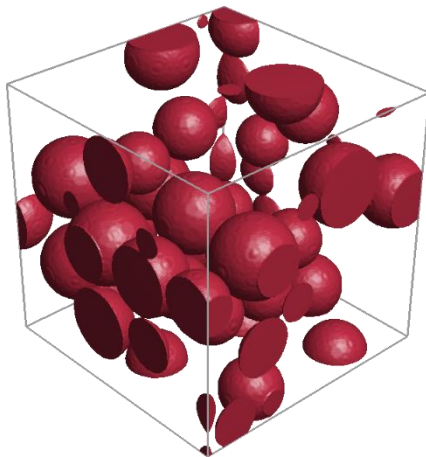
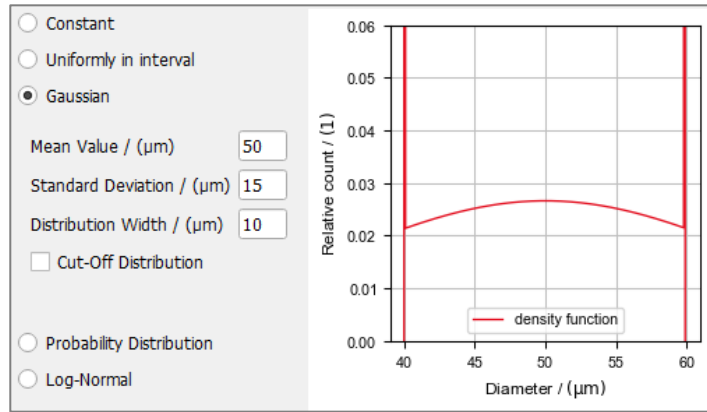
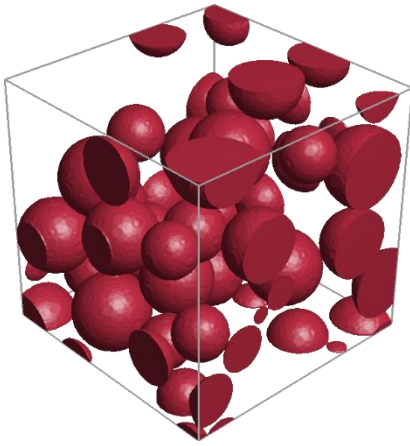

Probability Distribution

The **Probability Distribution** table allows entering user-defined probability distributions. The **Number of Rows** can be increased or decreased to enter as many diameter (or other) **Values** and their **Count Probability**, between 0 and 1.

In our example, 50% of spheres have a diameter of 20 µm, 20% a diameter of 35 µm, and 30% a diameter of 5 µm.

Count	Probability	Value / (µm)
1	0.3	5
2	0.5	20
3	0.2	35

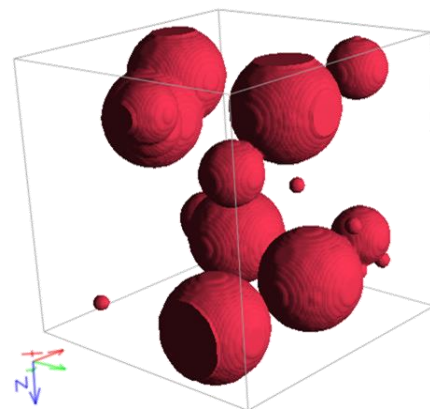

For large tables, it is useful to observe the value of **Probability Sum**, i.e. the sum of the count probabilities. When the **Probability Sum** is not equal to 1, click the **Normalize** button to automatically scale the **Count Probability** values. The buttons **Load...** and **Save...** allow loading a previous probability distribution and saving the current for later use.

Log-Normal

The **Log-Normal** distribution describes the situation in which the logarithm of the values follows a normal distribution. Further details on the logarithmic normal distribution can be found on the corresponding [Wikipedia](#) page.

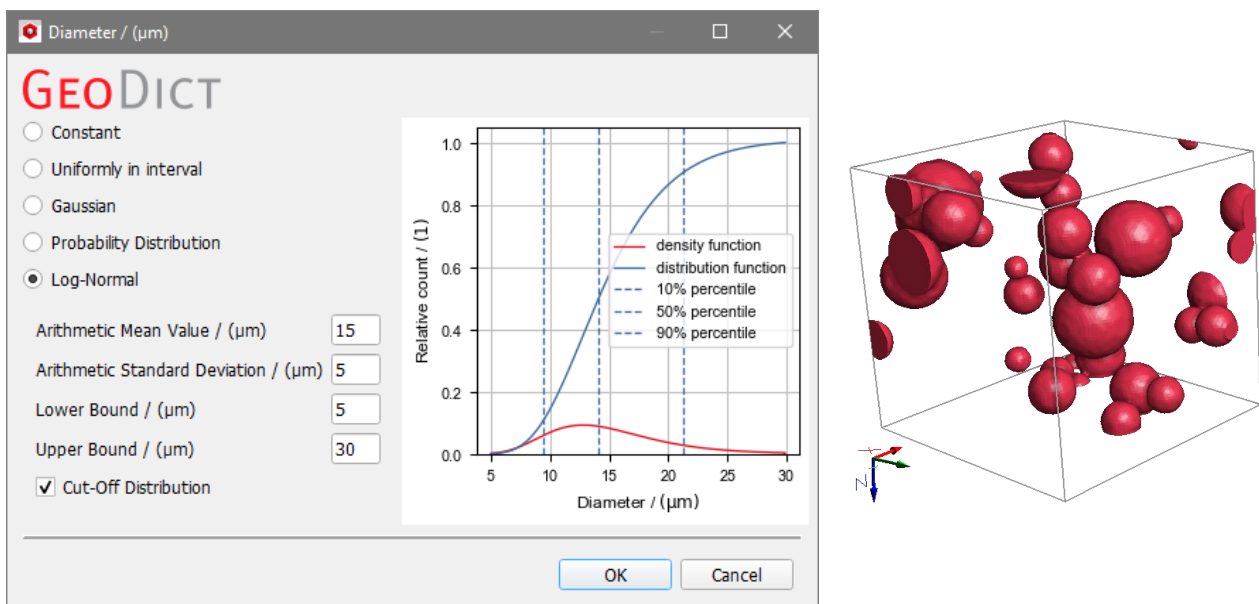

The values group around the entered **Arithmetic Mean Value** ($E[x]$) and scatter according to the entered **Arithmetic Standard Deviation** ($SD[x]$) of the log-normally distributed variable x . The values in **Lower Bound** and **Upper Bound** restrict the possible values to the given interval.

The diameters are distributed according to the log-normal distribution with mean value of 15 µm. All diameters must lie between 5 µm (lower bound) and 30 µm (upper bound).

Diameter, Inner Diameter Fraction, Aspect Ratio, Wall Thickness, Amplitude Fraction

The **Diameter** value can be edited by clicking **Edit...** to open the **Diameter** dialog. The diameter can be set to a **Constant** value, or to follow a diameter distribution (**Uniformly in interval**, **Gaussian**, **Probability Distribution**, or **Logarithmic-Normal (Log-Normal)**) as indicated above in pages [32ff.](#)

Spheres or the spheres building a sphere agglomerate, short fibers, as well as pyramids are defined by one diameter value. For the objects among them, which have a second diameter, the **Aspect Ratio** or the **Wall Thickness** value determine the other diameter value. **Ellipsoids**, **Superquadric Particles** and **Boxes** are defined by three diameters (Diameter 1, Diameter 2, and Diameter 3) which control the shape and size of the object.

Diameter 1 / (μm)	70
Diameter 2 / (μm)	50
Diameter 3 / (μm)	40

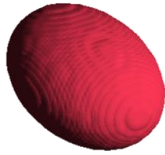

Diameter 1 / (μm)	50
Diameter 2 / (μm)	50
Diameter 3 / (μm)	30

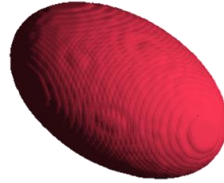

Diameter 1 / (μm)	90
Diameter 2 / (μm)	40
Diameter 3 / (μm)	20

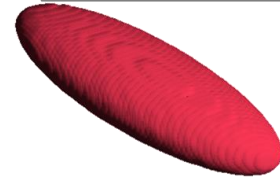

For non-circular fibers, the diameter but also other parameters control their shape. For a hollow fiber, the **Inner Diameter Fraction** defines the ratio of the entered (outer) diameter to the inner diameter.

Diameter [μm]	20
Inner Diameter Fraction	0.25

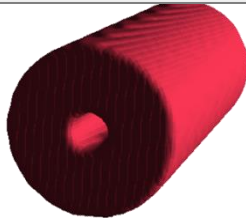

Diameter [μm]	20
Inner Diameter Fraction	0.5

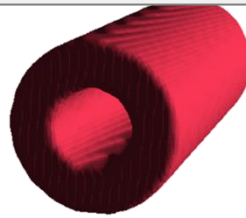

Diameter [μm]	20
Inner Diameter Fraction	0.75

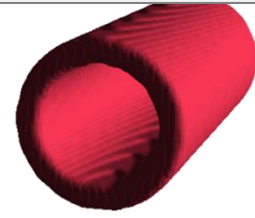

For short elliptical fibers, defined by two diameters, the **Aspect Ratio** is the relationship between the longer diameter **Diameter 1** and the shorter diameter **Diameter 2**.

Diameter 1 / (μm)	20
Aspect Ratio	0.25

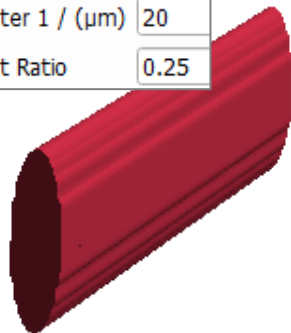

Diameter 1 / (μm)	20
Aspect Ratio	0.5

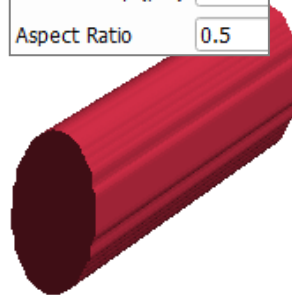

Diameter 1 / (μm)	20
Aspect Ratio	0.75

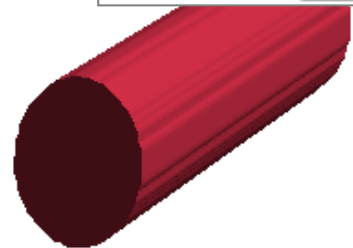

For fibers with Rosetta cross-section, the **Amplitude Fraction** determines the length of the Rosetta leaves, and the **Number of Leaves** defines how many leaves the Rosetta has.

Diameter / (μm)	20
Amplitude Fraction	0.25
Number of Leaves	4

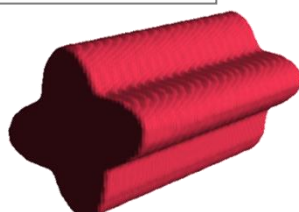

Diameter / (μm)	20
Amplitude Fraction	0.5
Number of Leaves	4

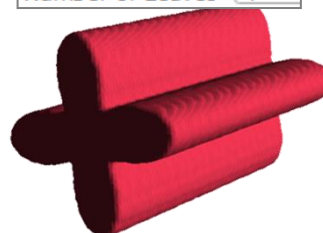

Diameter / (μm)	20
Amplitude Fraction	0.75
Number of Leaves	4

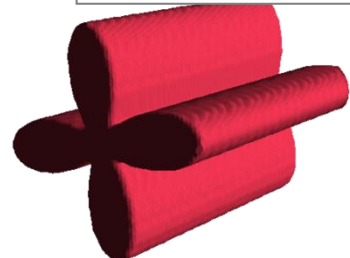

For a Convex Polyhedron, the shape determining parameters depends on the chosen **Enclosing Object**. For a **Sphere**, **Ellipsoid** or **Pyramid** as **Enclosing Object**, the respective diameters must be set as described above.

Length, Side Length and Ray Length

The three values of **Length** for boxes and the **Length** for all short fibers, the **Side Length** of short rectangular fibers, as well as the **Ray Length** of planar polyhedrons are editable by clicking **Edit...** and choosing the desired settings in the **Length** dialog.

The **Length**, **Side Length**, and **Ray Length** can be set to take a **Constant** value, or to follow a distribution (**Uniformly in interval**, **Gaussian**, **Probability Distribution**, or **Logarithmic-Normal**).

Boxes are defined by **Length 1**, **Length 2**, and **Length 3** which control the shape and size of the object.

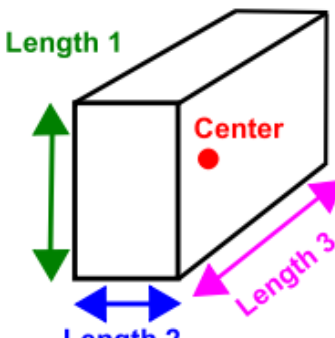

Length 1 / (μm)	10
Length 2 / (μm)	10
Length 3 / (μm)	20

Length 1 / (μm)	5
Length 2 / (μm)	5
Length 3 / (μm)	50

Length 1 / (μm)	5
Length 2 / (μm)	5
Length 3 / (μm)	90



For short rectangular fibers, the **Side Length 1** and the **Aspect Ratio** can be entered. The relationship between these parameters is like that between **Diameter 1** and **Aspect Ratio** for short elliptical cross-sectioned fibers explained above.

Side Length 1 / (μm)	15
Aspect Ratio	0.25

Side Length 1 / (μm)	15
Aspect Ratio	0.5

Side Length 1 / (μm)	15
Aspect Ratio	0.75

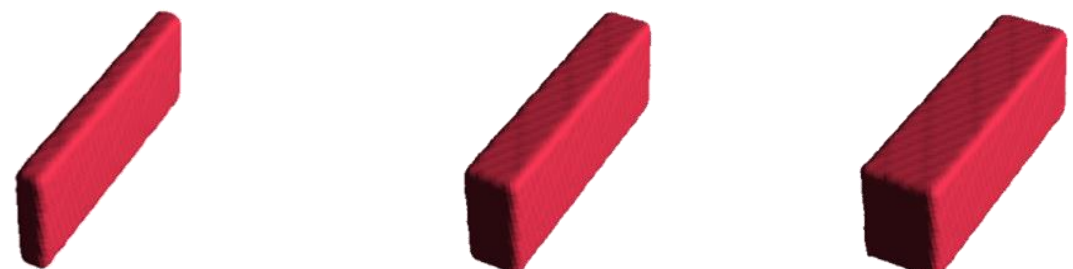

For planar polyhedrons, the **Ray Length** is the distance from the center of the object to any of the edges.

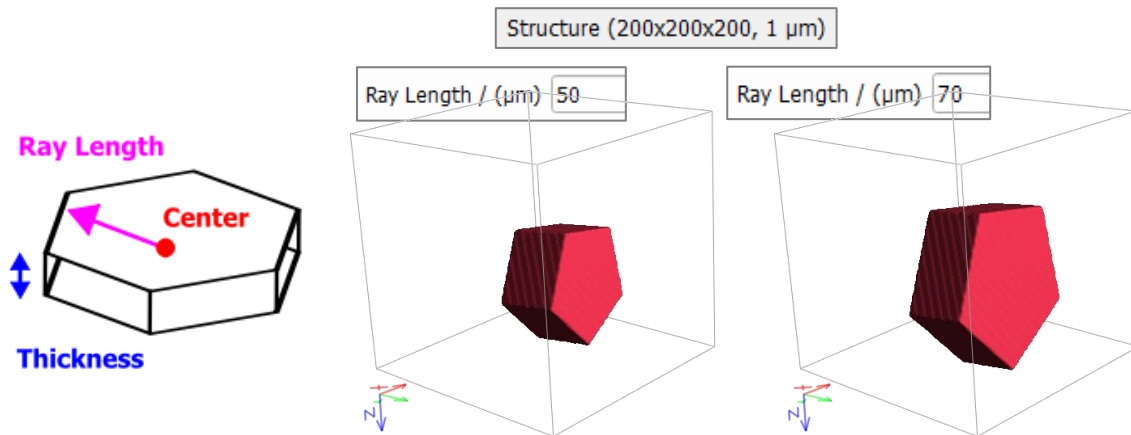

When choosing a **Box** as **Enclosing Object** for a **Convex Polyhedron**, the **Lengths** must be defined according to the **Box** object.

Number of Spheres and Aggregate Mode

For **Sphere Agglomerates** the **Number of Spheres** defines how many spheres build one agglomerate. The value can either be constant or follow a distribution.

The **Aggregate Mode** defines how the spheres are agglomerated. They can be agglomerated **Branch Like**, **Sphere Like** or in an **Intermediate** state between those two.

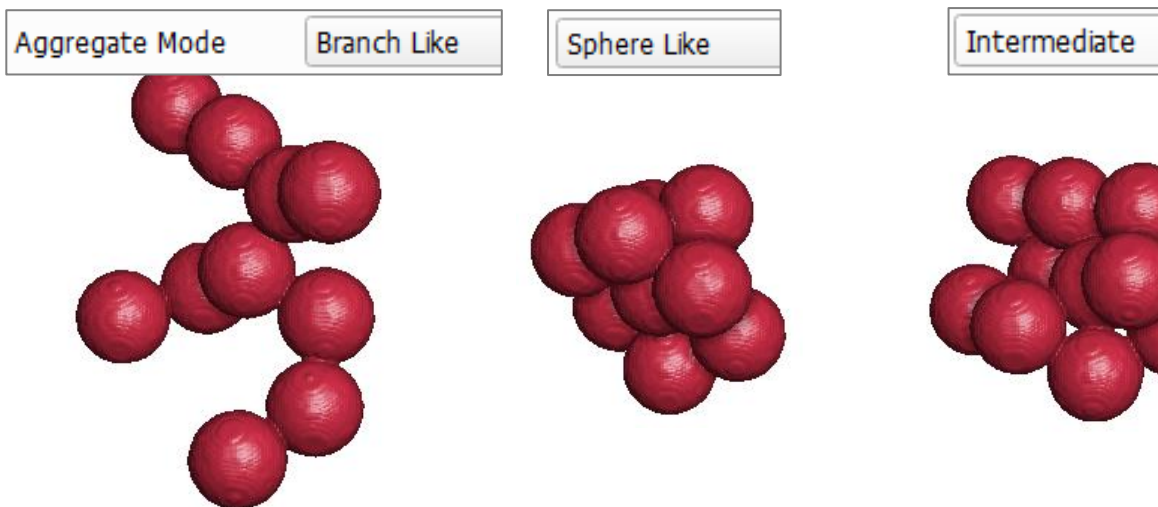

Blockiness

For **Superquadric Particles** the parameters **Blockiness 1** and **Blockiness 2** control the shape of the object. The entered values must be positive, otherwise an error message appears, when clicking **Generate**.

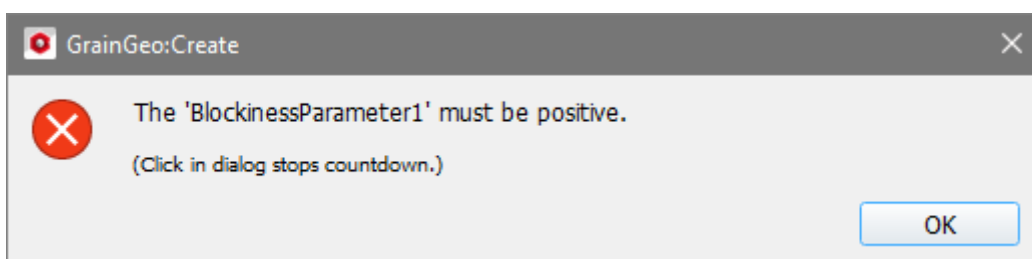

The surface of a **Superquadric Particle** is implicitly defined by the formula:

$$\left(\left| \frac{x}{d_1} \right|^{b_2} + \left| \frac{y}{d_2} \right|^{b_2} \right)^{\frac{b_1}{b_2}} + \left| \frac{z}{d_3} \right|^{b_1} = 1$$

The three **Diameter** values correspond to the diameters d_1, d_2, d_3 in the formula, **Blockiness 1** to the exponent b_1 and **Blockiness 2** to the exponent b_2 .

For exponents $b_1 = b_2 = 1$ the particle takes the shape of an octahedron, exponents $b_1 = b_2 = 2$ lead to an ellipsoidal shape, and for higher exponents the shape approaches a rectangular box.

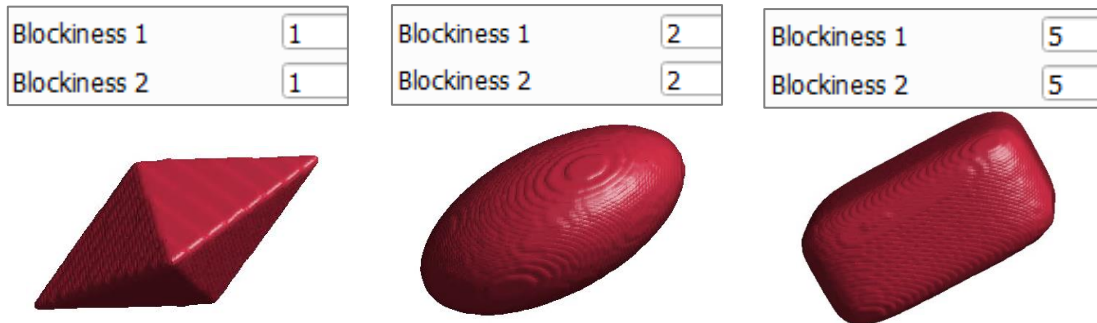

Parameters between 0 and 1 lead to a concave surface and might decrease the size defined by the diameters. Thus, it is recommended to use values of at least 0.5.



Blockiness 1 describes the shape in the plane defined by **Diameter 1** and **Diameter 2** as shown on the right and the plane described by **Diameter 1** and **Diameter 3**. **Blockiness 2** describes the shape in the plane described by the diameters **Diameter 2** and **Diameter 3**.

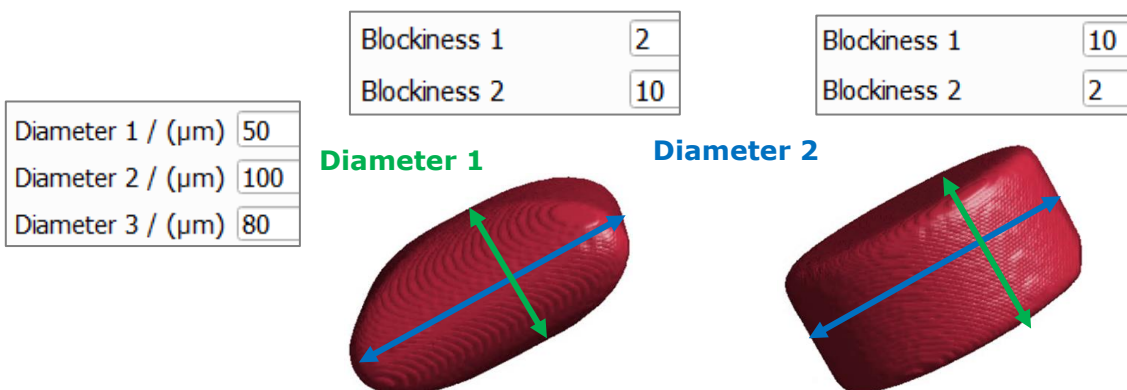
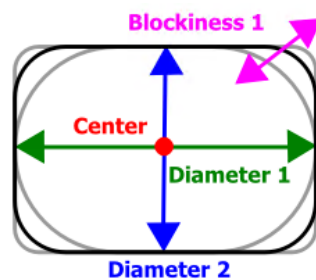

Point Mode, Number of Random Points, Match Enclosing Object Volume

To generate **Convex Polyhedrons**, several random points (**Number of Random Points**), serving as vertices of the polyhedron, are placed inside the chosen **Enclosing Object**.

Number of Random Points Number of Random Points Number of Random Points



The **Point Mode** defines if the vertices of the polyhedron can be defined anywhere inside the **Volume** of the enclosing object, or if they must lay on its **Surface**.

Point Mode

Enclosing Object Point Mode Point Mode



Additionally, checking **Match Enclosing Object Volume** scales the object size until the volume is as big as the volume of the enclosing object. Leaving this option unchecked always leads to a smaller volume.

Enclosing Object Match Enclosing Object Volume Match Enclosing Object Volume



Scaling Factor and Browse for Combined Object

Combined Objects are created through the combination of two or more objects (which have the same or different object types). They must be generated beforehand with GadGeo and saved in GAD-format. To learn how to generate combined objects with GadGeo refer to the [GadGeo](#) handbook of this User Guide.

Click **Browse ...** in the right column of the **Object Type** panel to select and import combined objects from a *.gad-file. The Christmas tree example for combined objects is included in the installation folder.

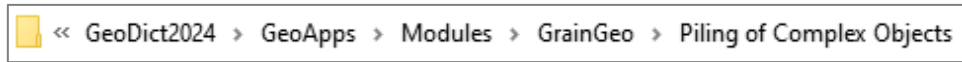

The **Scaling Factor** controls the size of the objects. A scaling factor of 1 generates the selected combined object with original size.

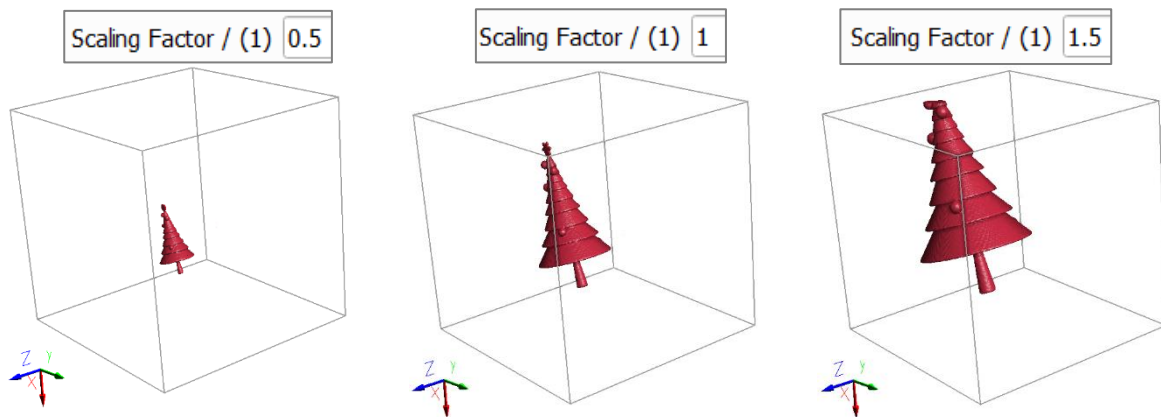

Orientation

All objects in the generated granular structure have either isotropic or anisotropic orientation. The **Orientation** of an object type in a generated structure can be set by clicking the **Edit...** button. The orientation can be separately set for each object type so that differently oriented objects may coexist within the same structure.

In the **Orientation** dialog, objects can be defined to be **Isotropic**, have a certain **Anisotropic Direction**, **Anisotropic Orientation**, **Given Directions**, are oriented **In XY-Plane** or have a maximum **Angle Around Direction**. See how to set the values for Anisotropy 1 and 2 (pages 54ff.)

For all object types, either with a rotationally symmetric cross-section (such as **Circular** and **Hollow** fibers), or with rotationally asymmetric cross-sections, it is possible to control the object direction (isotropic or anisotropic) and the position of the cross-section with respect to the XY-plane as well (see below, page 48).

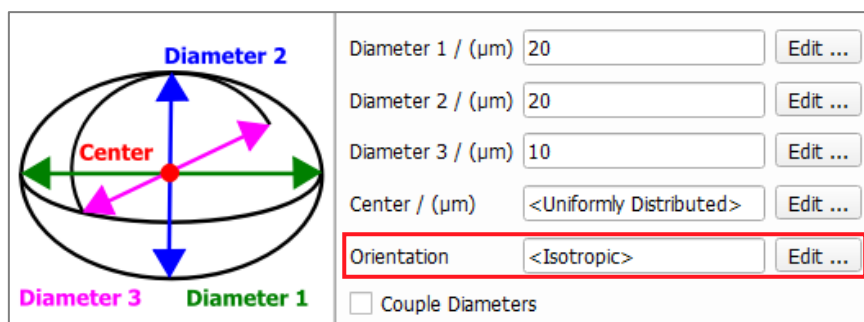

 Isotropic

In an **Isotropic** orientation, all directions have the same probability.

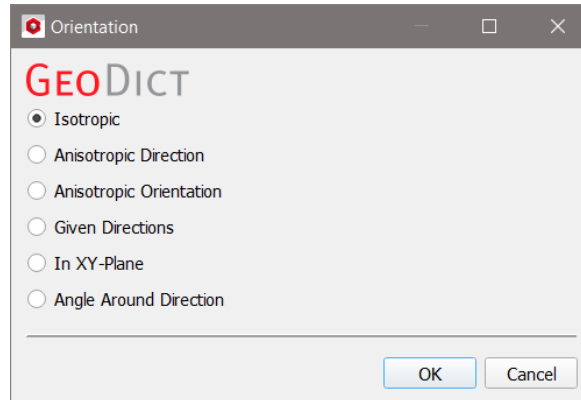

 Anisotropic Direction

When checking **Anisotropic Direction** and selecting **Anisotropy Parameter** from the **Direction Mode** pull-down menu, the **Anisotropy Parameters** (Anisotropy 1 and Anisotropy 2, see pages [54ff.](#)), as well as the **Phi**, **Theta** and **Psi** [Euler Angles](#) for the three-dimensional rotation of anisotropic objects can be defined.

In this case, the positions of cross-sections to the XY-plane are isotropic (and not entered).

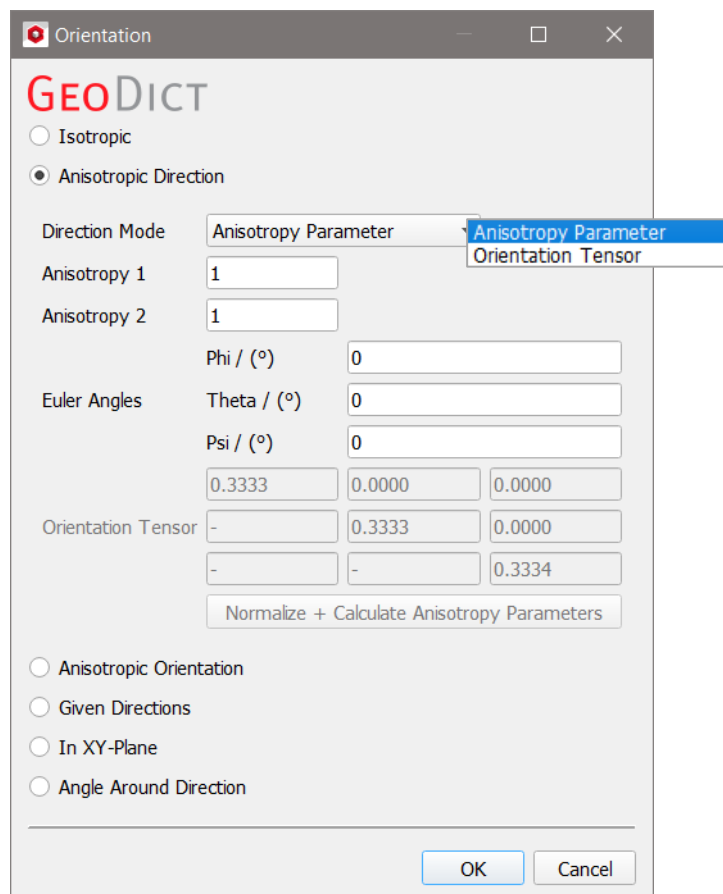

The Euler rotation angles are applied to the objects during the generation following the order Phi → Theta → Psi.

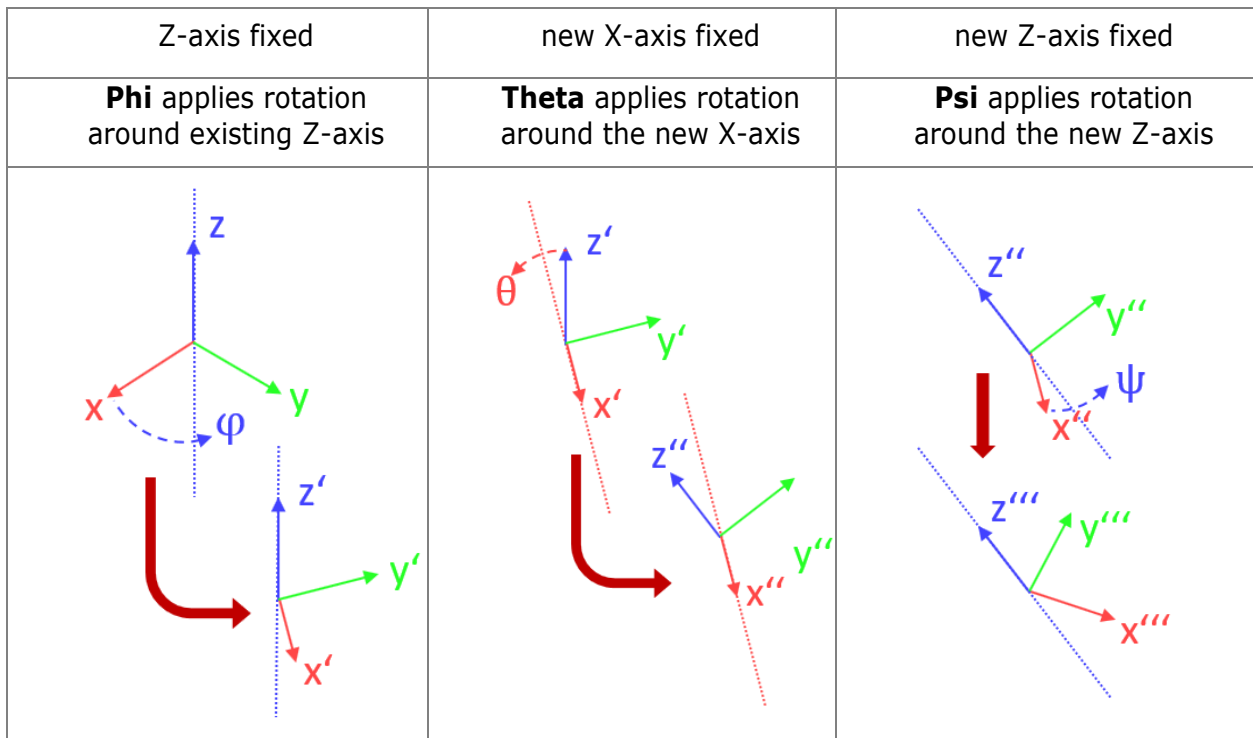

Alternatively, when selecting **Orientation Tensor** from the **Direction Mode** pull-down menu, the values for the direction tensor of the anisotropic objects can be entered.

The **Orientation Tensor** provides an equivalent alternative to the combination of the **Anisotropy Parameters** and the **Euler Angles**.

Orientation

GEODICT

Isotropic

Anisotropic Direction

Direction Mode: Orientation Tensor

Anisotropy 1:

Anisotropy 2:

Phi / (°):

Euler Angles: Theta / (°):

Psi / (°):

Orientation Tensor

Normalize + Calculate Anisotropy Parameters

Anisotropic Orientation

Given Directions

In XY-Plane

Angle Around Direction

Clicking **Normalize + Calculate Anisotropy Parameters** button enters the adjusted values in the orientation tensor and the Anisotropy 1 and Anisotropy 2 boxes.

In detail, let $\mathbf{d}_k = \begin{pmatrix} x_k \\ y_k \\ z_k \end{pmatrix}$ be the unit vector describing the direction of the k^{th} objects and n the number of objects. Then the orientation tensor \mathbf{T} is the sum over the dyadic products of the \mathbf{d}_k from all n objects, divided by n :

$$\mathbf{T} = \frac{1}{n} \left(\sum_{k=1}^n \mathbf{d}_k \mathbf{d}_k^T \right) = \frac{1}{n} \sum_{k=1}^n \begin{pmatrix} x_k x_k & x_k y_k & x_k z_k \\ y_k x_k & y_k y_k & y_k z_k \\ z_k x_k & z_k y_k & z_k z_k \end{pmatrix} = \begin{pmatrix} t_{11} & t_{12} & t_{13} \\ t_{21} & t_{22} & t_{23} \\ t_{31} & t_{32} & t_{33} \end{pmatrix}.$$

The diagonal elements define the orientation strength for the corresponding directions and sum up to 1. Thus, if for example $t_{11} = 1$ (and $t_{22} = t_{33} = 0$), all objects are oriented in the X-direction. For $t_{11} = 0$ all objects are oriented normally to the X-direction and same values for all diagonal elements ($t_{11} = t_{22} = t_{33} = \frac{1}{3}$) result in a uniform distribution for the object orientation.

Observe the effect of changing the shown values of the isotropic **Orientation Tensor** to obtain anisotropic structures oriented in:

X-direction

0.7	0.0000	0.0000
-	0.15	0
-	-	0.15

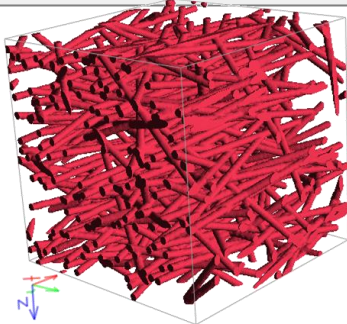

Y-direction

0.15	0.0000	0.0000
-	0.7	0
-	-	0.15

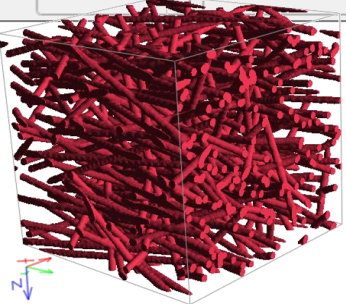

Z-direction

0.15	0.0000	0.0000
-	0.15	0
-	-	0.7

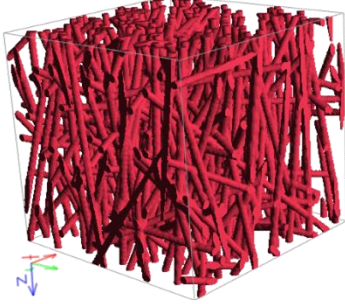

Anisotropic Orientation

To control not only the object direction, but also the position of the cross-section with respect to the XY-plane, check **Anisotropic Orientation** and select either **Anisotropy Parameter** or **Orientation Tensor** from the **Orientation Mode** pull-down menu.

The angle between the object cross section axis and XY-plane can be entered in the **Profile Angle to XY-Plane** dialog.

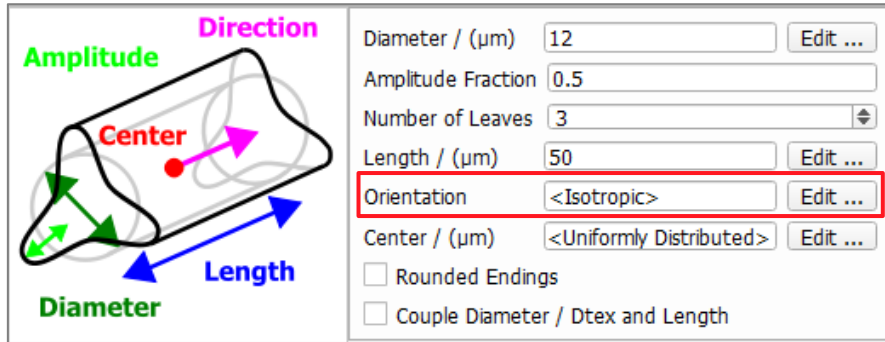

The object **Profile Angle to XY-Plane**, can be set to be a **Constant** value, or to follow a distribution (**Uniformly in interval**, **Gaussian**, or **Probability Distribution**).

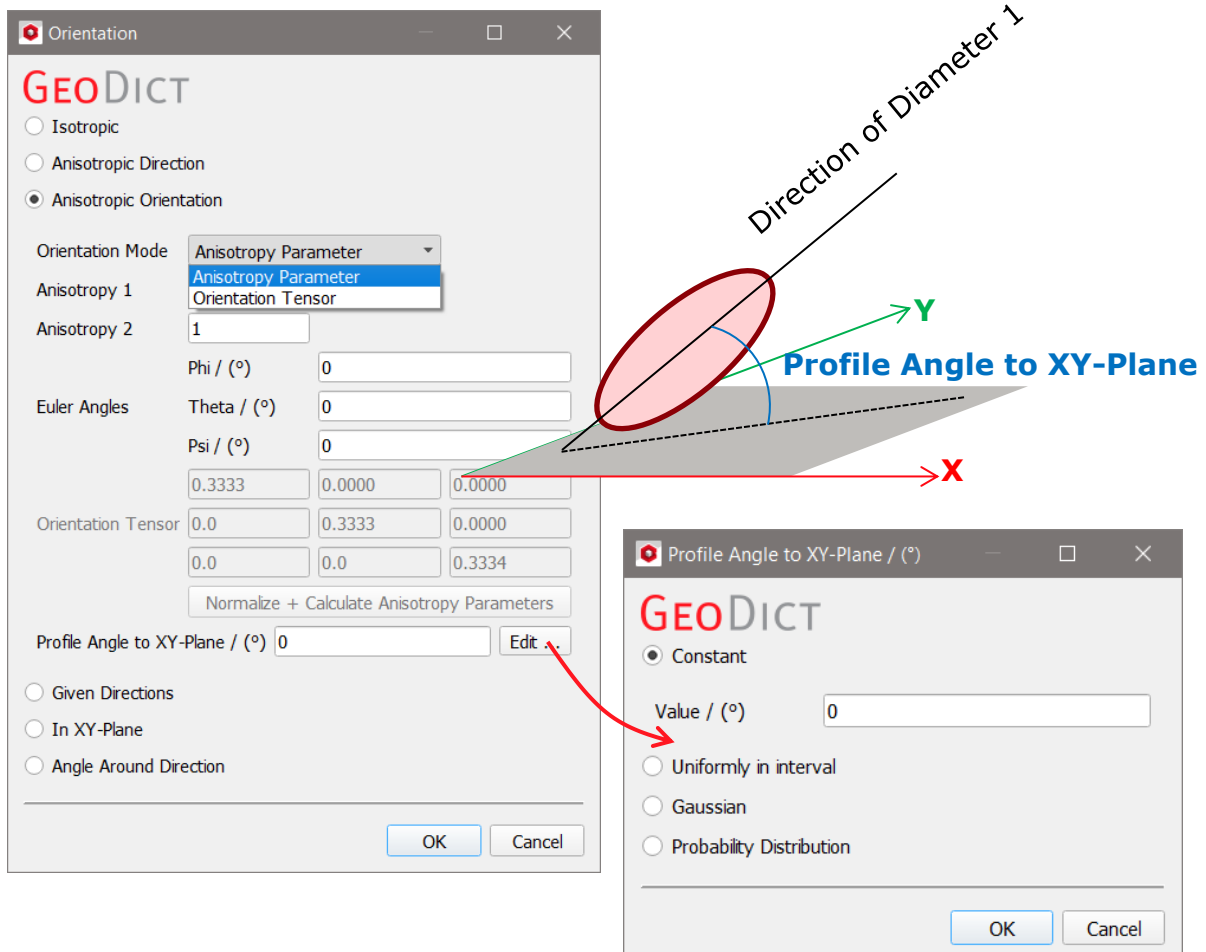

Observe the effect of varying the **Profile Angle To XY-Plane** in a structure made of Short Elliptical fibers strongly oriented in the Y-axis (Anisotropy 1 = 1, Anisotropy 2 = 1000). Other parameters are unchanged.

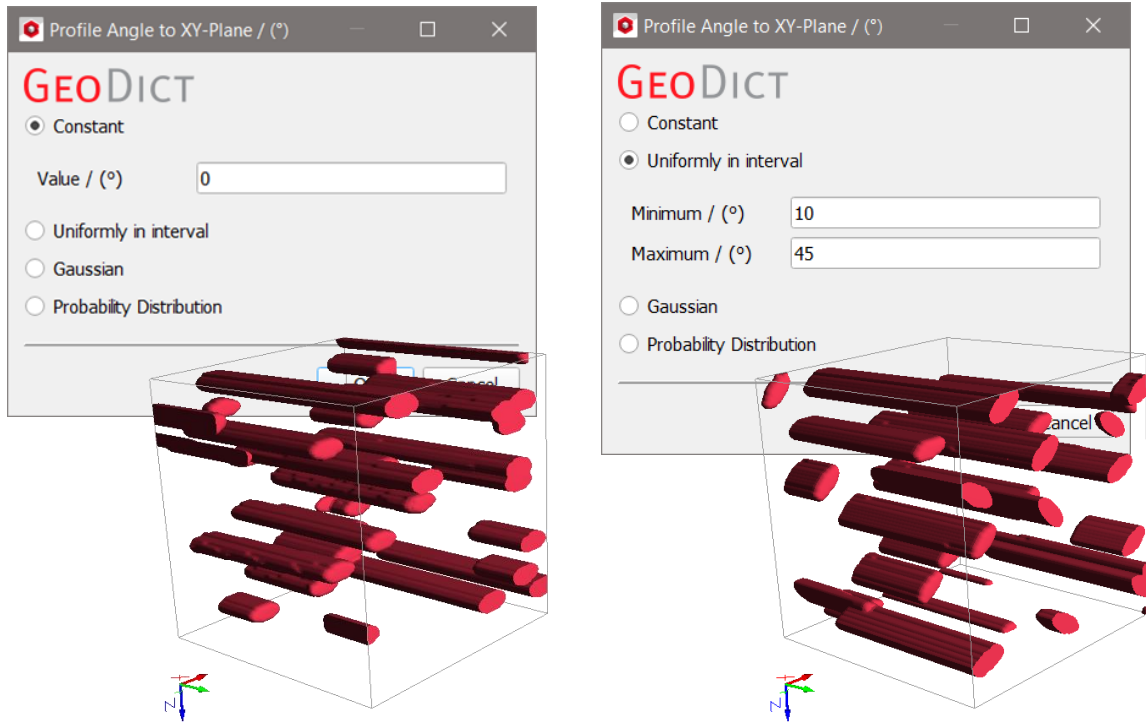

In the following example, a **Probability Distribution** is defined. 50% of the elliptical fibers are at an angle of 45° with the XY-plane, 30% lie on the plane (0° angle), and 20% are at a 25° angle.

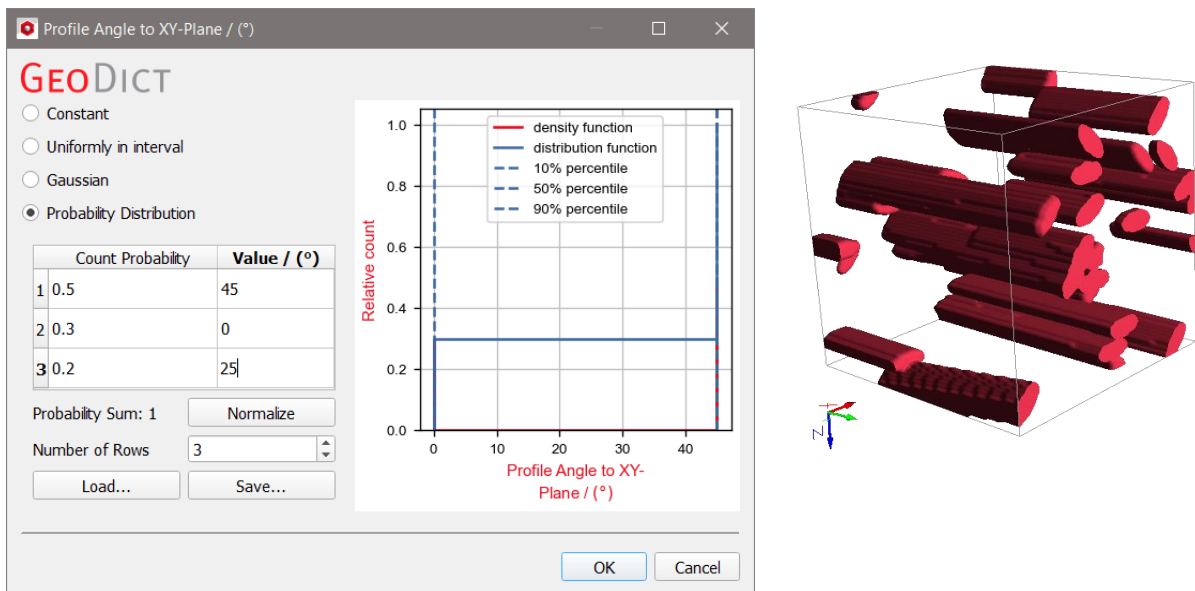

Given Directions

By checking **Given Directions**, a distribution gradient can be entered for different direction vectors for the objects in the generated structure.

In the left column the **Count Probability** can be entered. A value of 1 means all objects will have the given direction on the right. For example, a **Count Probability** of 1 for the direction vector 0, 0, 1 means that all objects follow the Z-direction, and 1, 0, 0 means that all objects follow the X-direction.

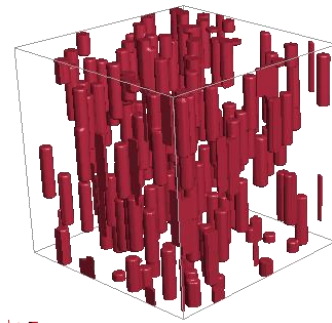
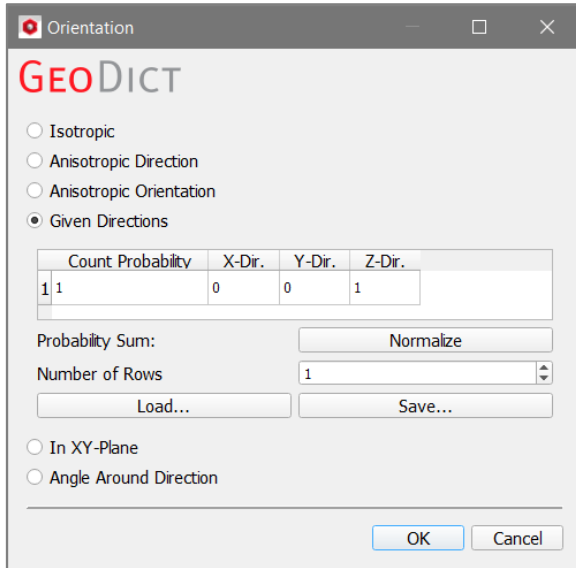

	Count Probability	X-Dir.	Y-Dir.	Z-Dir.
1	1	1	0	0

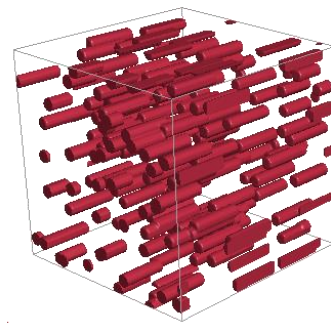

If more rows are given, every given direction will be applied to the generated objects with the corresponding count probability. In the following example observe how 80% of the short circular fibers are oriented in X-direction while the other 20% are oriented along the Z-axis.

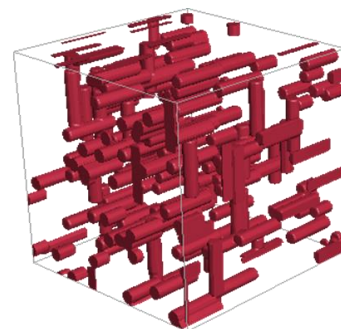
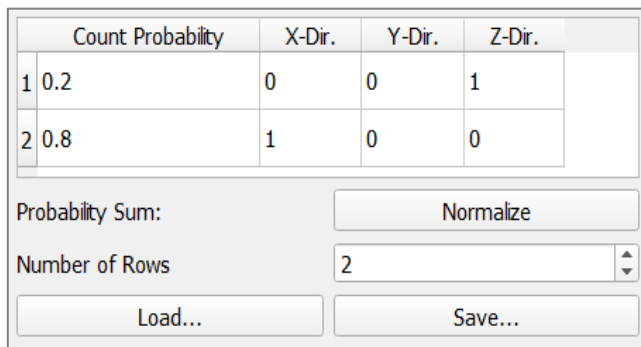

Clicking the **Normalize** button ensures the Count Probability values sum up to one. The Given Directions distribution settings can be saved and loaded by clicking **Save** and **Load**, respectively.

Every direction in the 3-dimensional space is possible, as seen in these examples:

Count	Probability	X-Dir.	Y-Dir.	Z-Dir.
1	1	1	0	1

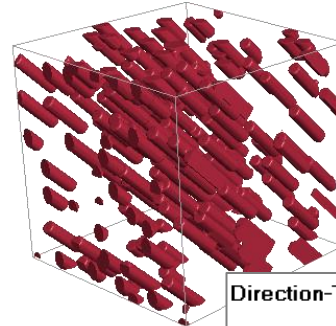

Direction-Tensor Object Type 1:

Realized Direction Tensor:

0.5000	0.0000	0.5000
-	0.0000	0.0000
-	-	0.5000

Count	Probability	X-Dir.	Y-Dir.	Z-Dir.
1	1	1	0.5	0

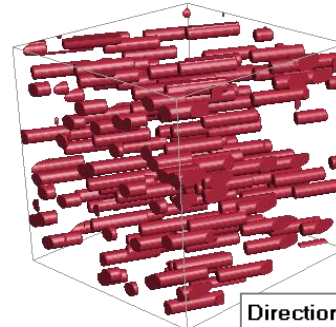

Direction-Tensor Object Type 1:

Realized Direction Tensor:

0.8000	0.4000	0.0000
-	0.2000	0.0000
-	-	0.0000

In XY-Plane

By checking **In XY-Plane**, the angle of the objects main axis in the XY-Plane can be set. The objects lay on the XY-Plane and their main axis orientation in relation to the X-direction is controlled by the entered value.

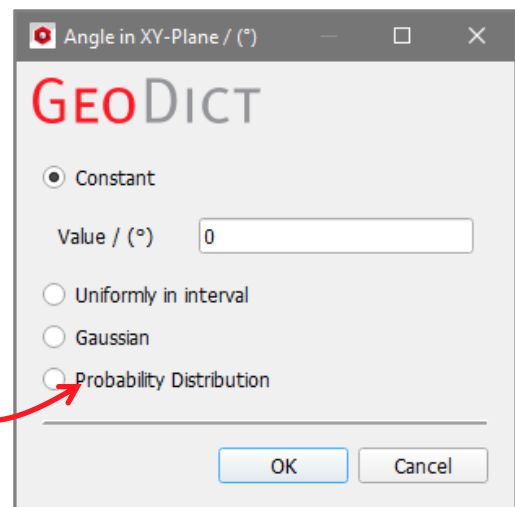
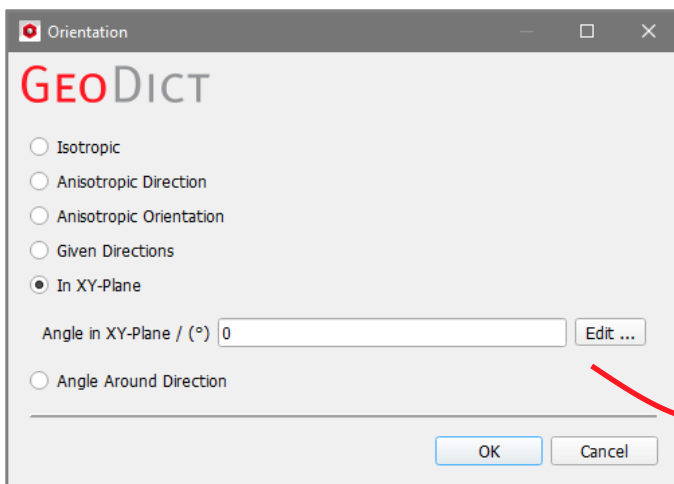

For example, enter 0°, 30°, 45°, or 90°, to obtain the following orientations in the XY-Plane:

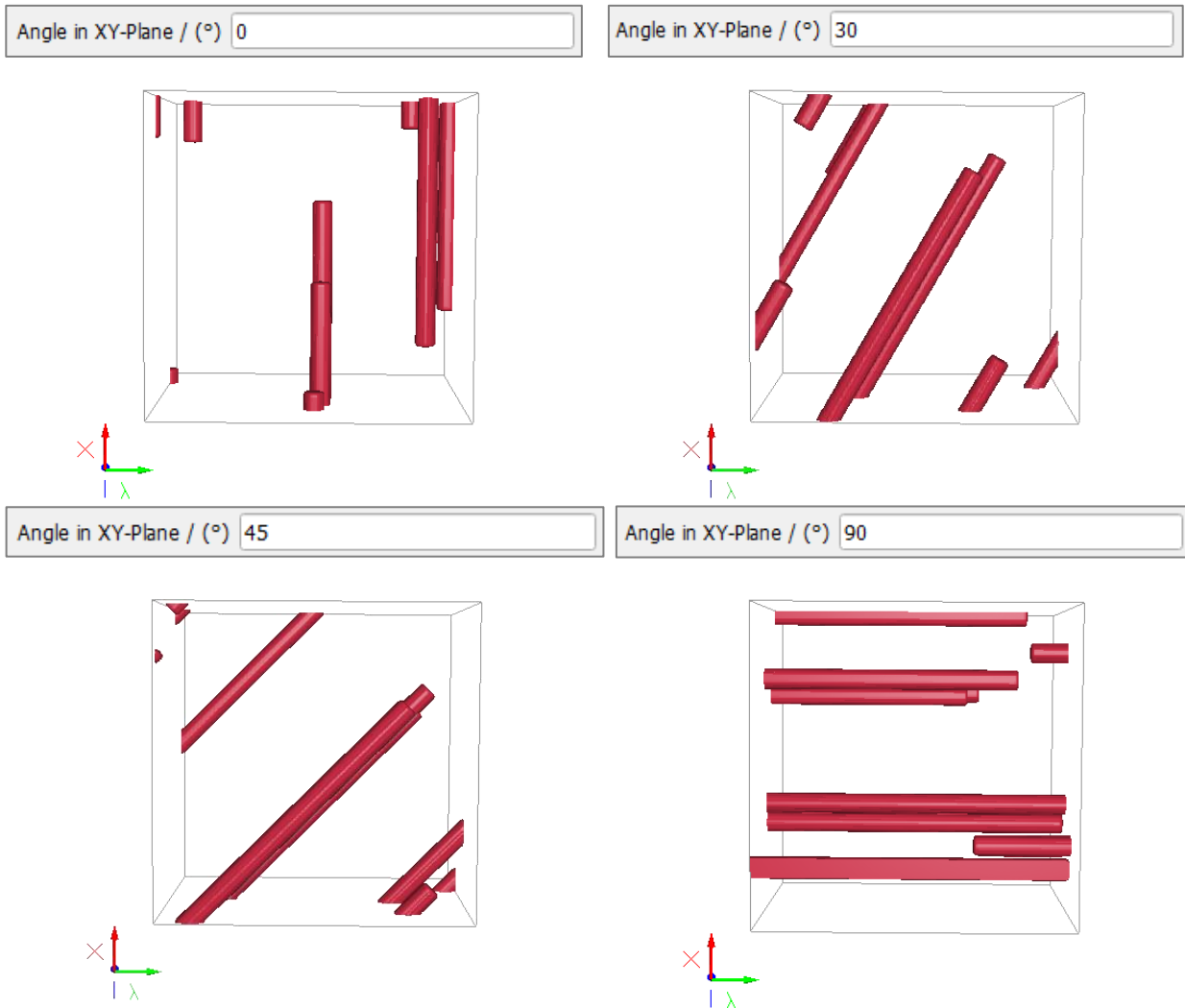

Angle Around Direction

If **Angle Around Direction** is checked define the **Main Direction Vector** of the objects generated in the structure. The orientation of the objects can vary if an **Angle Around Direction** is given.

The **Angle Around Direction** defines the maximum angle the object orientation varies from the Main Direction.

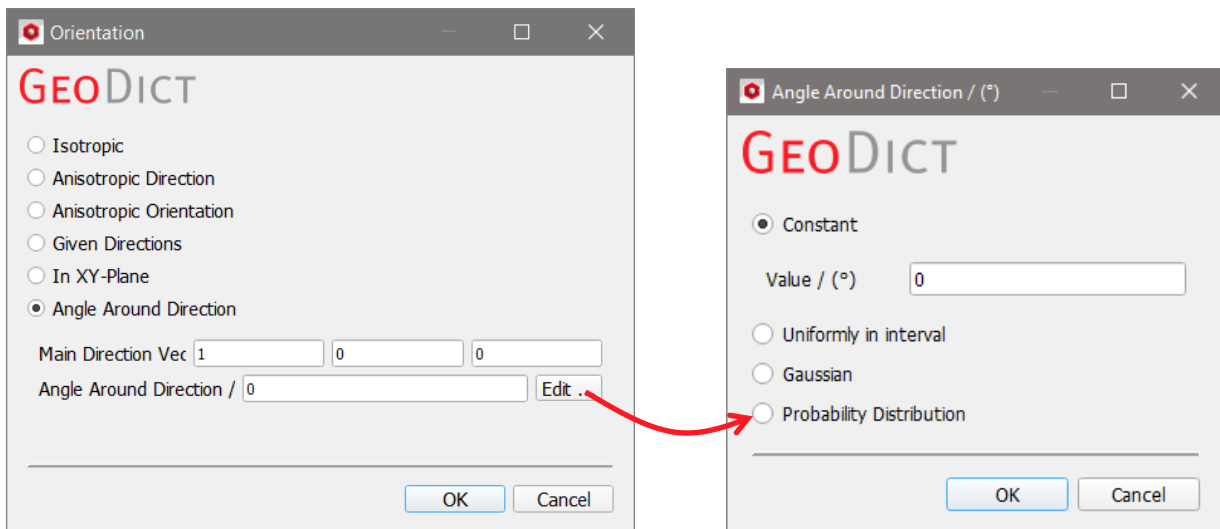

Observe how the orientation varies in the following example with angles around direction of 0°, 5° and 10° and a **Main Direction Vector** of (1, 0, 0).

Angle Around Direction

Main Direction Vector

Angle Around Direction / (°)

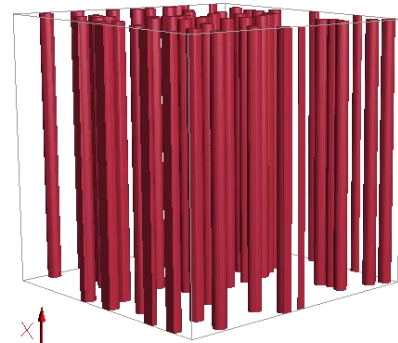

Angle Around Direction

Main Direction Vector

Angle Around Direction / (°)



Angle Around Direction

Main Direction Vector

Angle Around Direction / (°)

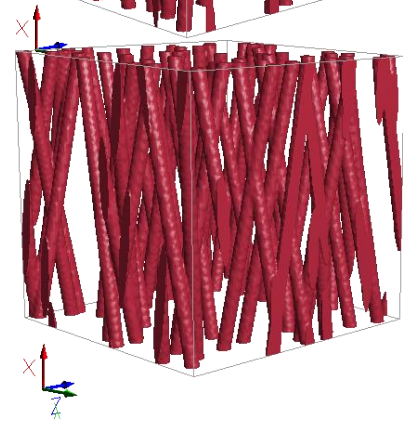

Setting Anisotropy Parameters

The **Anisotropy Parameters**, **Anisotropy 1** (a_1) and **Anisotropy 2** (a_2), allow to define the orientation of the grains. Anisotropy parameters and the Orientation Tensor are equivalent representations for the orientation, and GeoDict can compute one from the other automatically. The grains are created with random orientations, following a distribution defined by the given parameters.

The Algorithm

For each grain, a random direction is computed

$$d = \begin{pmatrix} x \\ y \\ z \end{pmatrix}$$

which follows an isotropic distribution. Afterwards the **Anisotropy Parameters** are used to influence these orientations. Before normalization, the resulting vector for the grain orientation is:

$$d_a = \begin{pmatrix} x_a \\ y_a \\ z_a \end{pmatrix} = \begin{pmatrix} a_1 \cdot x \\ a_1 \cdot a_2 \cdot y \\ z \end{pmatrix}$$

With normalization follows:

$$d_{normalized} = \frac{1}{|d_a|} d_a = \frac{1}{\sqrt{(a_1 x)^2 + (a_1 a_2 y)^2 + z^2}} \begin{pmatrix} a_1 x \\ a_1 a_2 y \\ z \end{pmatrix}$$

Before normalization, **Anisotropy 1** controls the first two coordinates, while **Anisotropy 2** only affects the second coordinate and none of them changes the third. After normalization, the anisotropy parameters both have impact on all three coordinates, where the influence on the grain direction differs. Whereas high values for **Anisotropy 1** lead to grains parallel to the XY-plane, high values for **Anisotropy 2** result in grains oriented in Y-direction. Grains oriented in Z-direction are obtained by low values for Anisotropy 1 and low values for **Anisotropy 2** result in grains parallel to the XZ-plane.

In the following five main cases for the Anisotropy parameters are described:

Anisotropy 1 = Anisotropy 2 (Isotropic material)

The grain orientation is isotropic. All directions have the same probability, as the direction obtained from the random algorithm is not changed:

$$d_a = \begin{pmatrix} a_1 x \\ a_1 a_2 y \\ z \end{pmatrix} = \begin{pmatrix} 1 \cdot x \\ 1 \cdot 1 \cdot y \\ z \end{pmatrix} = \begin{pmatrix} x \\ y \\ z \end{pmatrix} = d$$

Orientation

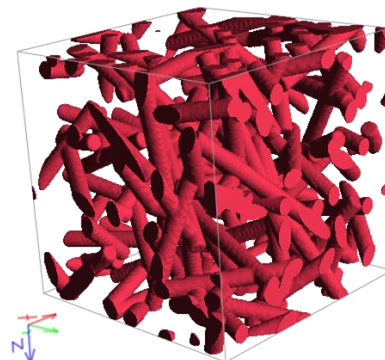
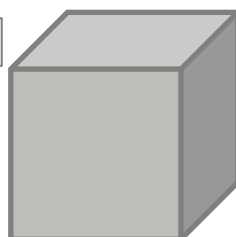

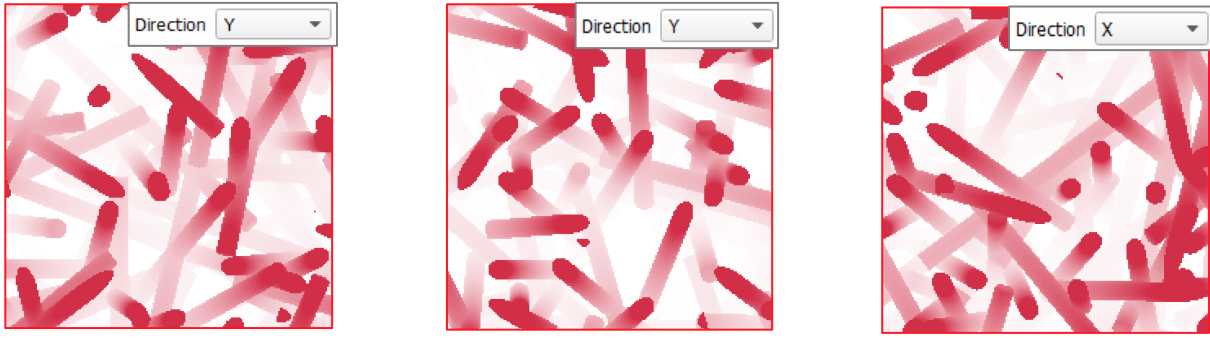

Anisotropy 1 < 1

Values smaller than 1 for **Anisotropy 1** lead to orientations in Z-direction, so that the grains are parallel to the YZ-plane and the XZ-plane when viewed from the X- or Y-direction. The smaller the value of **Anisotropy 1**, the more anisotropic the grains behave.

For example, with the values 0.01 for **Anisotropy 1** and 1 for **Anisotropy 2** it follows:

$$d_a = \begin{pmatrix} a_1 x \\ a_1 a_2 y \\ z \end{pmatrix} = \begin{pmatrix} 0.01 \cdot x \\ 0.01 \cdot y \\ z \end{pmatrix}$$

Thus, after normalization the direction vectors of the grains approximate the unit vector:

$$d_{normalized} = \frac{1}{\sqrt{0.0001 \cdot x^2 + 0.0001 \cdot y^2 + z^2}} \begin{pmatrix} 0.01 \cdot x \\ 0.01 \cdot y \\ z \end{pmatrix} \cong \begin{pmatrix} 0 \\ 0 \\ 1 \end{pmatrix}$$

That results in grains oriented in Z-direction.

Anisotropy 1

Anisotropy 2

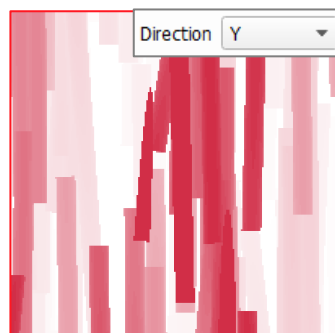
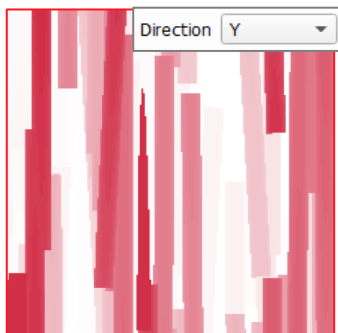
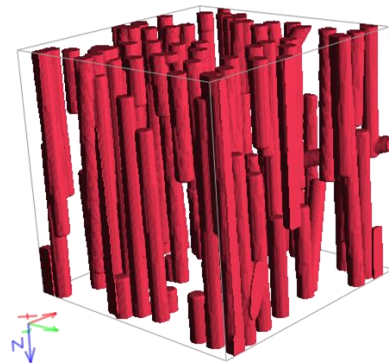
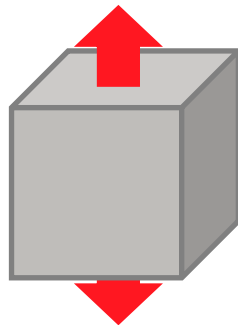

Anisotropy 1 > 1

The grains are isotropic in the XY-plane (Z-slice). The higher the value of **Anisotropy 1**, the stronger is the anisotropy.

For example, with the values 100 for **Anisotropy 1** and 1 for **Anisotropy 2** it follows:

$$d_a = \begin{pmatrix} a_1 x \\ a_1 a_2 y \\ z \end{pmatrix} = \begin{pmatrix} 100 \cdot x \\ 100 \cdot y \\ z \end{pmatrix}$$

Thus, after normalization the direction vectors of the grains approximate the vector:

$$d_{normalized} = \frac{1}{\sqrt{10000 \cdot x^2 + 10000 \cdot y^2 + z^2}} \begin{pmatrix} 100 \cdot x \\ 100 \cdot y \\ z \end{pmatrix} \cong \begin{pmatrix} x \\ y \\ 0 \end{pmatrix}$$

That results in grains oriented in the XY-plane.

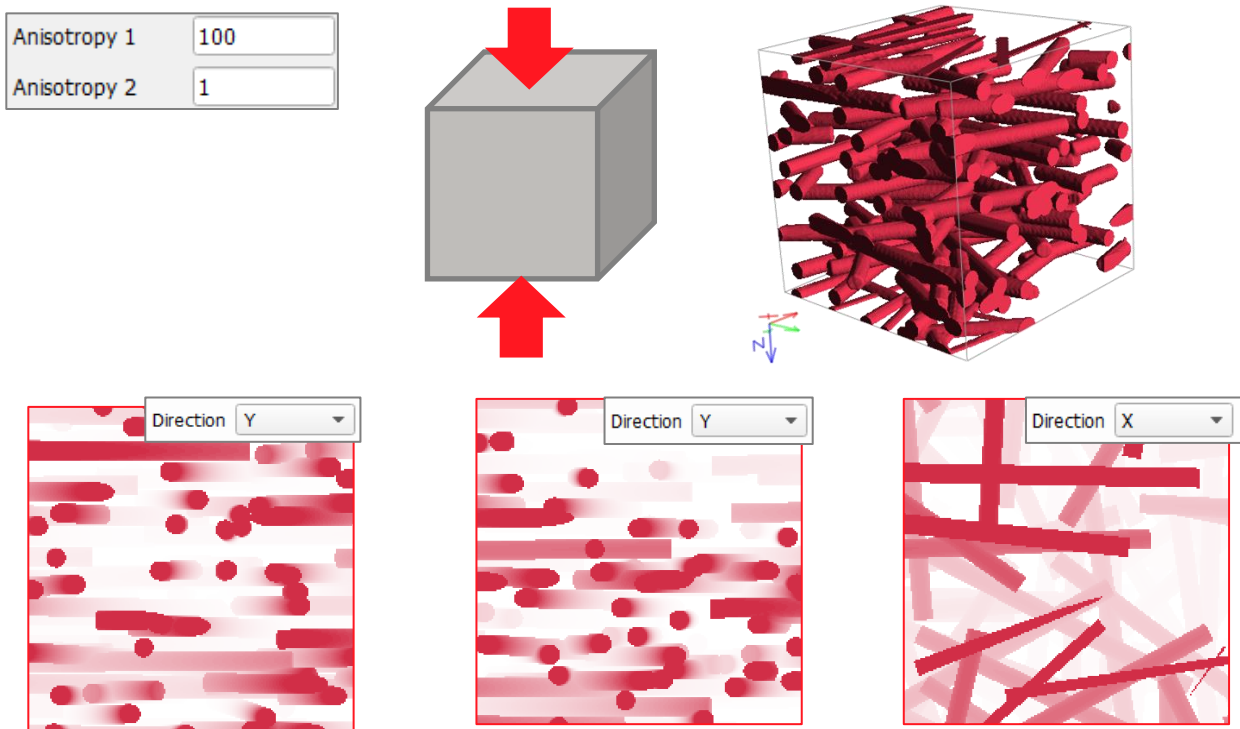

Anisotropy 2 < 1

Small values for **Anisotropy 2** lead to grains oriented parallel to the XZ-plane. Observe that the grains are isotropic in the XZ-plane (Y-slice).

For example, with the values 1 for **Anisotropy 1** and 0.01 for **Anisotropy 2** it follows:

$$d_a = \begin{pmatrix} a_1 x \\ a_1 a_2 y \\ z \end{pmatrix} = \begin{pmatrix} x \\ 0.01 \cdot y \\ z \end{pmatrix}$$

Thus, after normalization the direction vectors of the grains approximate the vector:

$$d_{normalized} = \frac{1}{\sqrt{x^2 + 0.0001 \cdot y^2 + z^2}} \begin{pmatrix} x \\ 0.01 \cdot y \\ z \end{pmatrix} \cong \begin{pmatrix} x \\ 0 \\ z \end{pmatrix}$$

That results in grains oriented in the XZ-plane.

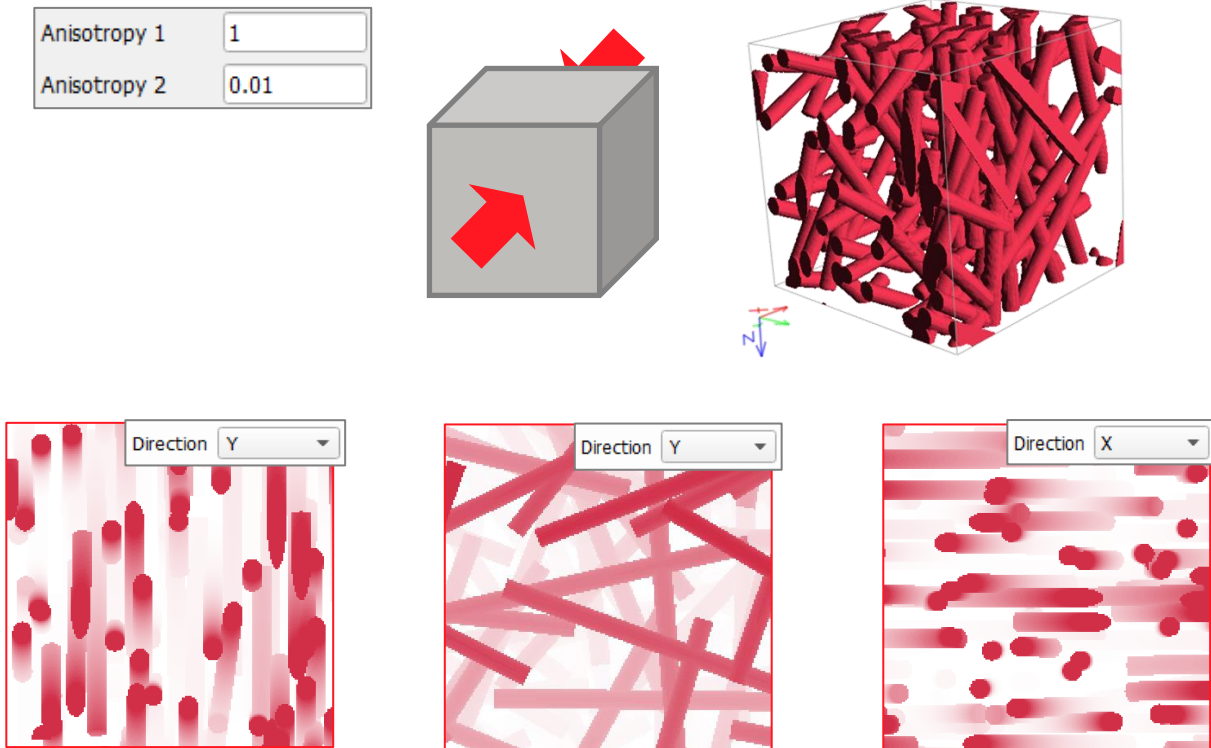

Anisotropy 2 > 1

The higher the values for **Anisotropy 2**, the more the grains tend to be oriented along the Y-axis. Observe that the grains cut the XZ-plane (Y-slice), while they run parallel to the YZ-plane and the XY-plane when viewing them from the X- or the Z-direction.

For example, with the values 1 for **Anisotropy 1** and 100 for **Anisotropy 2**, it follows:

$$d_a = \begin{pmatrix} a_1x \\ a_1a_2y \\ z \end{pmatrix} = \begin{pmatrix} x \\ 100 \cdot y \\ z \end{pmatrix}$$

Thus, after normalization the direction vectors of the grains approximate the unit vector:

$$d_{normalized} = \frac{1}{\sqrt{x^2 + 10000 \cdot y^2 + z^2}} \begin{pmatrix} x \\ 100 \cdot y \\ z \end{pmatrix} \cong \begin{pmatrix} 0 \\ 1 \\ 0 \end{pmatrix}$$

That results in fibers oriented in Y-direction.

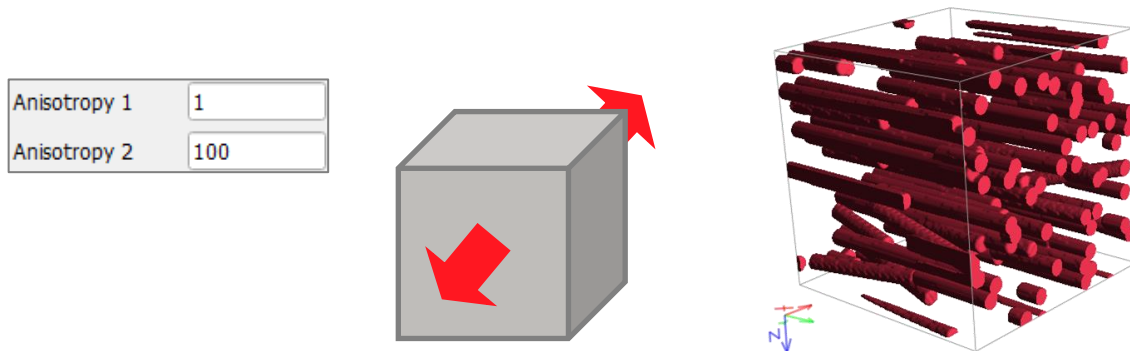

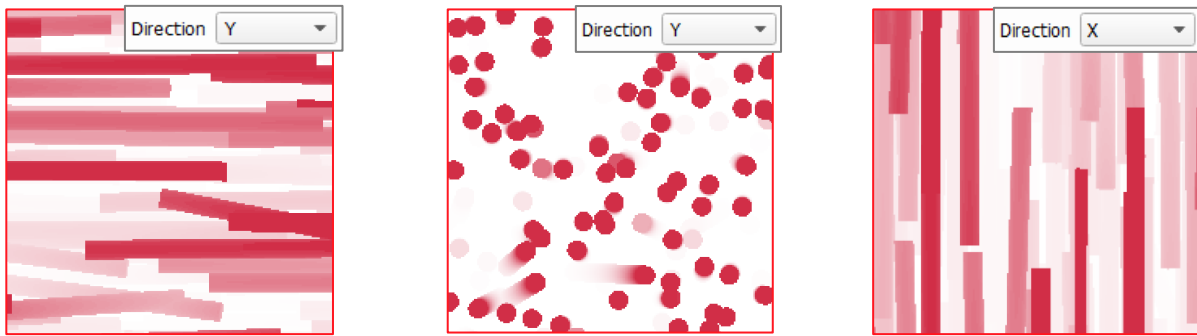

Different anisotropy values for different object types

As mentioned before, the orientation can be separately set for each object type so that differently oriented objects may coexist within the same structure. In the following structure, observe that **Anisotropy 1** and **Anisotropy 2** are set to 0.01 and 1 for the short circular (red) fibers. The short circular (gray) fibers have **Anisotropy 1** and **Anisotropy 2** of 1 and 100, respectively.

The red fibers tend to be oriented along the Z-axis, and the fibers run parallel when viewed from the X- or Y-direction.

The gray fibers tend to be oriented in the Y-axis and cut the XZ-plane, while they run parallel to the YZ-plane and the XY-plane, as observed from the X- or the Z-direction.

Infinite Circular

Material (ID 01) ■ Manual (Solid) ...

Anisotropy 1

Anisotropy 2

Short Circular

Material (ID 02) ■ Manual (Solid) ...

Anisotropy 1

Anisotropy 2

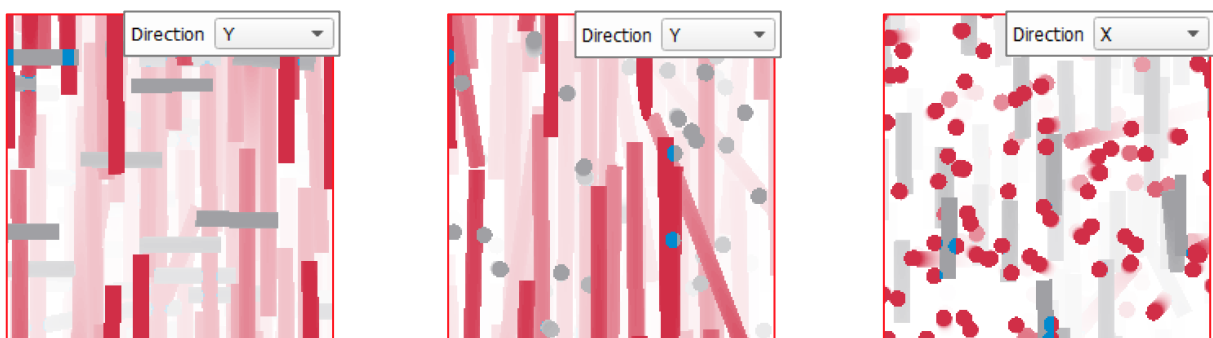
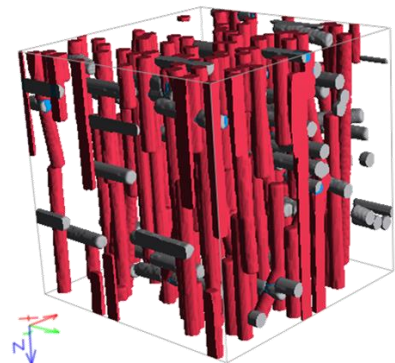

Center

The position of objects in a structure created with GrainGeo can be controlled by adjusting the position of their **Center** through the **Edit...** button.

Diameter 1 / (μm)	20	Edit ...
Diameter 2 / (μm)	20	Edit ...
Diameter 3 / (μm)	10	Edit ...
Center / (μm)	<Uniformly Distributed>	Edit ...
Orientation	<Isotropic>	Edit ...
<input type="checkbox"/> Couple Diameters		

The **Center** of the objects may be distributed **Uniformly, Uniformly in Box,** or follow a **Density Distribution.**

Uniformly

When **Uniformly** is checked, the random object center values are uniformly distributed across the whole structure. The uniform distribution of the centers is clearly observed in the example below.

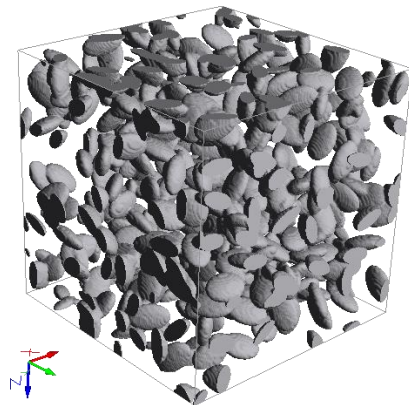

On Current Objects

After having selected **Create in Current Domain** under the **Create Options** tab, the centers can also be positioned **On Current Objects.**

Create Options	Object Options
<input type="checkbox"/> Create in Current Domain	

Create Options	Object Options
<input checked="" type="checkbox"/> Create in Current Domain	

Observe the placement of short circular fibers' centers on a conical structure generated with GadGeo, when **On Current Objects** is chosen in the **Center** dialog.

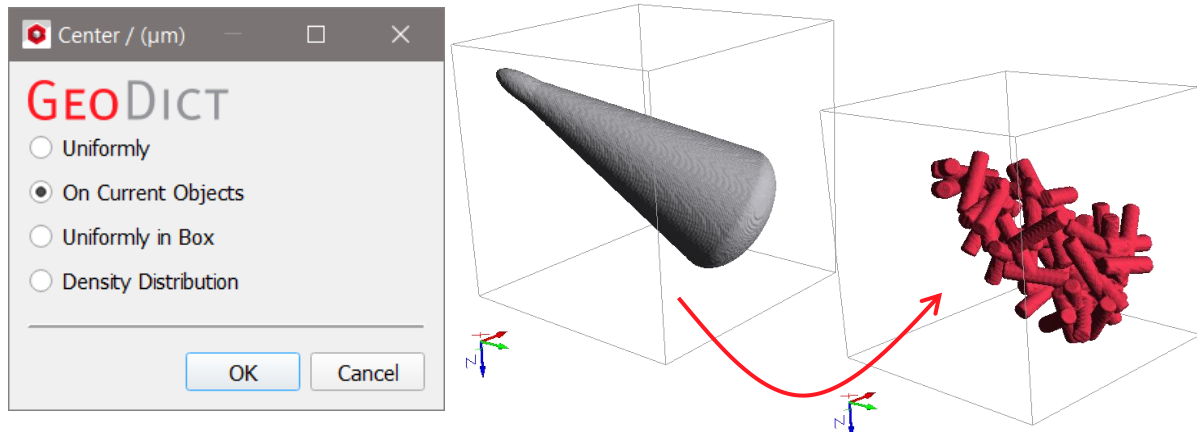

Uniformly in Box

With **Uniformly in Box** checked, the values entered for **X-min**, **X-max**, **Y-min**, **Y-max**, **Z-min** and **Z-max** limit the distribution of the center position to certain areas. These directionally limiting values define an area in which the structure occurs.

For a 200 x 200 x 200 µm structure, the values in the **Center** dialog limit an area in which the respective ellipsoid center is positioned between 20 µm and 100 µm in the X-direction, 30 µm and 100 µm in the Y-direction, and between the origin (0 µm) and the end of the domain in the Z-direction.

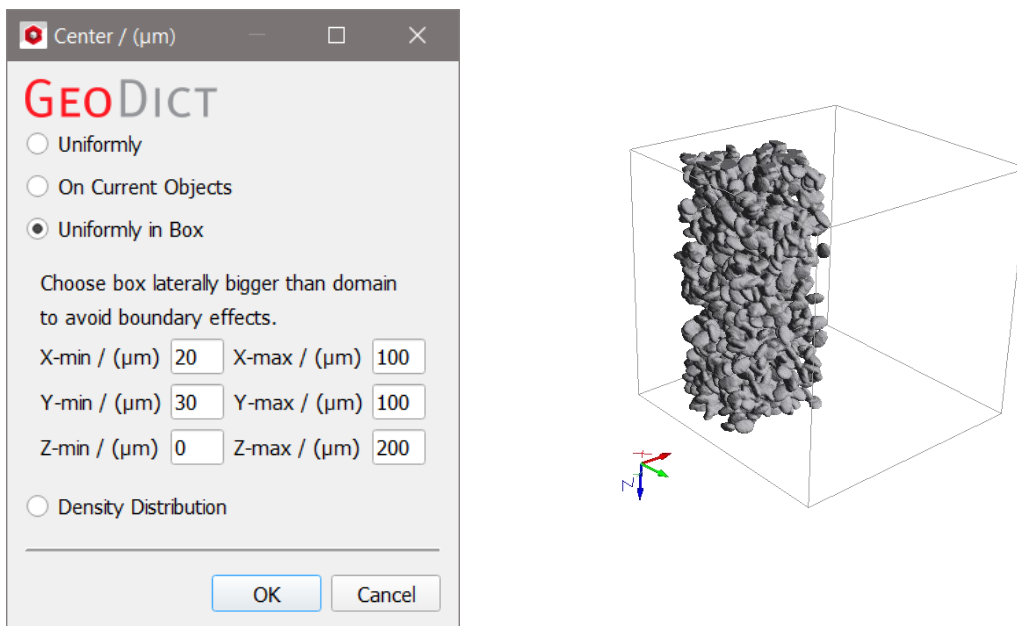

Density Distribution

The **Density Distribution** table describes the probability of a random center taking certain position values in Z-direction.

When checking **Use Relative Position** in the density distribution table, the left column values (from 0 to 1) correspond to locations in the structure. In the Z-direction, the value 0 is at the origin and the value 1 is at the end of the domain.

The right column assigns relative density values at these locations. The value **20** means that there are ten times more objects in $Z = 1$ than in $Z = 0.1$, with a density value of **2**. The object density increases and decreases linearly between the given locations in the Z-direction.

Observe how, with the values entered in the table ($0.1 \rightarrow 20$, $0.5 \rightarrow 0$, and $1 \rightarrow 0.2$), most pyramids occupy an area in the structure near the Z-origin ($Z = 0.1$), then there is an area almost empty of pyramids in the middle ($Z = 0.5$), and only some pyramids are at the end of the domain in Z-direction ($Z = 1$).

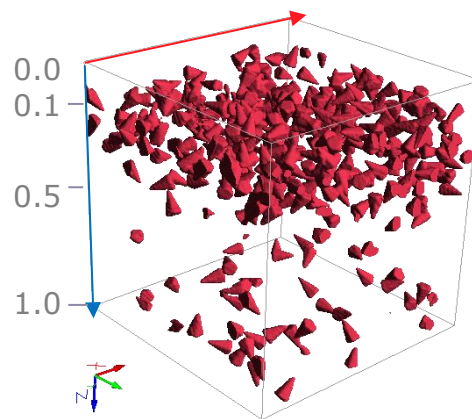
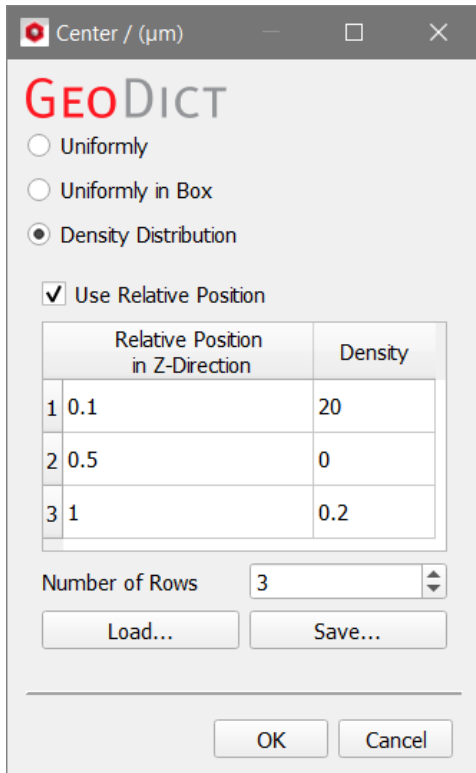

As before, with orientation, the distribution of centers can be separately set for each object type so that differently distributed object types may coexist within the same structure.

In the following example, observe that the gray ellipsoids are distributed **Uniformly in Box**, whereas the red pyramids follow a **Density Distribution**.

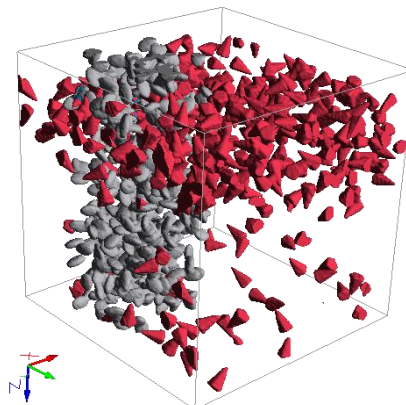

With **Use Relative Position** un-checked, the left column values of the density distribution table correspond to absolute locations in the structure.

In the Z-direction, in a structure of size 200 x 200 x 200 μm , the value 0 is at the origin and the value 200 is at the end of the domain. The right column assigns density values at these locations, where **0** means that pyramid centers are absent at that location, and **1** means that pyramid centers are present at the location.

Observe how, with the values in this table, the pyramids are distributed. The object density increases and decreases linearly between the given locations in the Z-direction.

Density Distribution

Use Relative Position

	Absolute Position in Z-Direction / (μm)	Density
1	0	0
2	10	1
3	50	1
4	50	1
5	200	0

Number of Rows: 5

Load... Save...

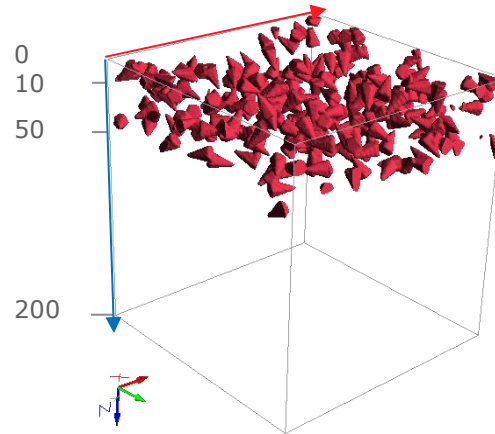

The center density distribution must be defined with monotonously increasing Z-values.

If Z is non-monotonic or monotonously decreasing, an error message appears when trying to generate the structure.

Density Distribution

Use Relative Position

	Relative Position in Z-Direction	Density
1	0	0
2	0.5	2
3	0.2	0
4	1	10

Number of Rows: 4

Load... Save..

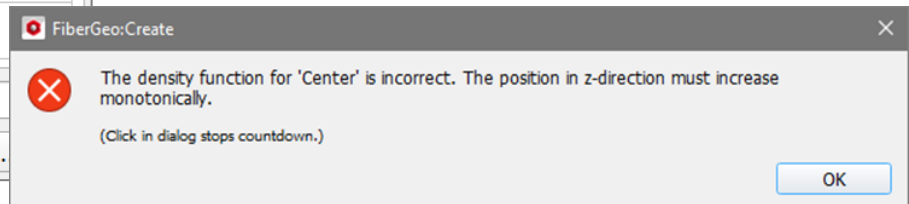

Rounded Endings

Short fibers with any cross-section (**Circular, Hollow, Rosetta, Cellulose, Elliptic, Rectangular** and **Angular**) can be created with or without rounded ends by checking or leaving un-checked the **Rounded Endings** box. Observe the variation in the shape of the short rectangular fibers after checking the **Rounded Endings** box.

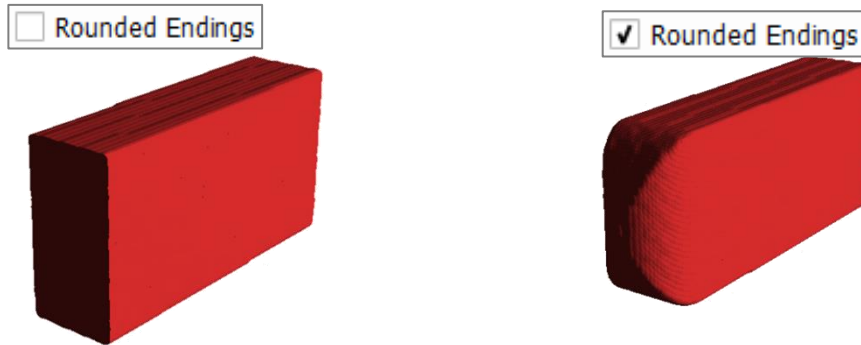

Couple Diameters, Couple Lengths, and Couple Diameter and Length

The diameters of ellipsoids, the lengths of boxes, and the **Diameter/Length** of short circular, hollow, angular, rosetta, elliptical, and cellulose fibers, or the **Side length/Length** of short rectangular fibers can be coupled by checking **Couple Diameters, Couple Lengths, and Couple Diameter and Length** or **Couple Side Length 1 and Length**.

Then, the boxes for the values of **Diameter, Length, or Side Length** disappear and an **Edit...** button appears. Click the **Edit...** button to couple these parameters through values entered in a probability distribution table.

The following structure, entirely made of short circular fibers, is generated with the coupled values for diameter and length entered in the probability distribution table shown.

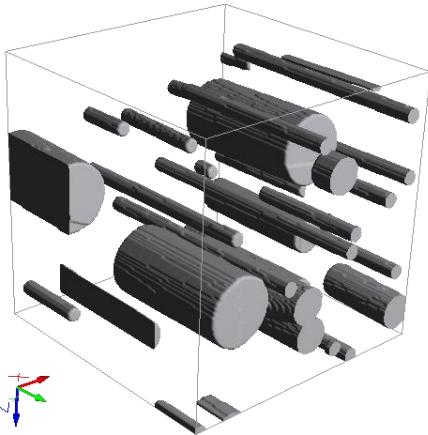
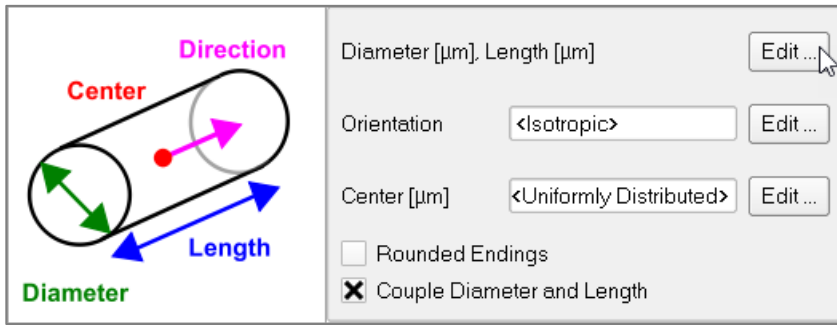

	Count	Probability	Diameter / (μm)	Length / (μm)
1	0.5	10	200	
2	0.2	50	100	
3	0.3	25	100	

Probability Sum:

Number of Rows:

Observe the three distinct sizes of short circular fibers: 50% with diameter 10 μm and length 200 μm, 20% with diameter 50 μm and length 100 μm, and 30% with diameter 25 μm and length 100 μm.

OBJECT OVERLAP

The options under the **Object Overlap** tab define the material IDs in locations where materials in the structure overlap. The overlap locations can have other properties than the original materials.

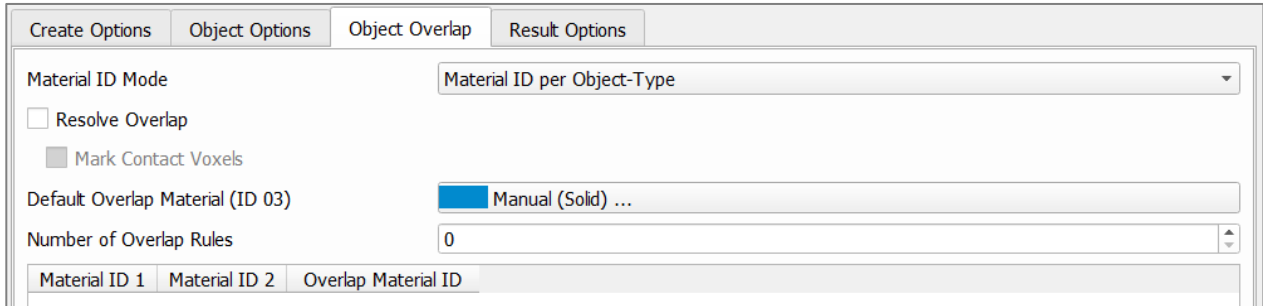

The **Material ID Mode** pull-down menu allows to select between two modes. **Material ID per Material** means that all objects with the same material receive the same **Material ID**. **Material ID per Object-Type** means that objects with different type obtain different **Material IDs**, even if they are made of the same material.

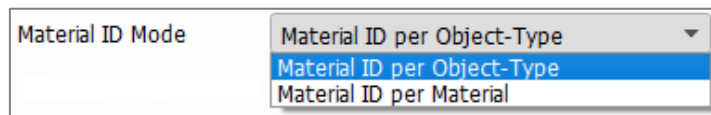

Assigning a Material ID is part of the **GeoDict** Material Database concept, in which objects in the structure are ascribed to an individual material (e.g. glass, iron, PET) with specific physical properties.

If **Resolve Overlap** is checked, the overlap is not assigned to a new material ID. Instead, the water-shed algorithm is used to decide which of the overlap voxels belongs to which object in a post-processing step. Thus, each overlap voxel is assigned to one specific object. This option needs more memory and a longer run-time.

In detail, the **Resolve Overlap** algorithm starts with computing a distance map for the overlap voxels, i.e. it computes the distance to the next object for each overlap voxel. On this distance map the watershed algorithm is run using all voxels belonging to an object as seeds. There, all voxels contained in the same object have the same material ID. Thus, the overlap area is filled with the object IDs according to the distance map.

To mark the contact voxels between the objects with a separate material ID, select **Mark Contact Voxels** and choose a **Contact Material** from the Material Data Base.

The voxels, where two or more object IDs meet, are marked as contact voxels, by reassigning them with a new material ID. Thus, the layer of contact voxels always has a thickness of two voxels.

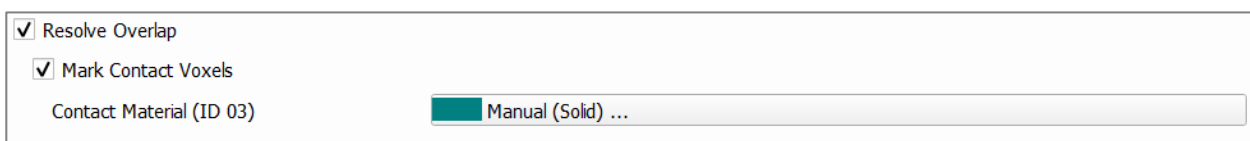

In the following observe the resulting Material IDs for the overlap for not resolved, resolved, and resolved overlap with marked contact voxels, while all other settings are kept the same.

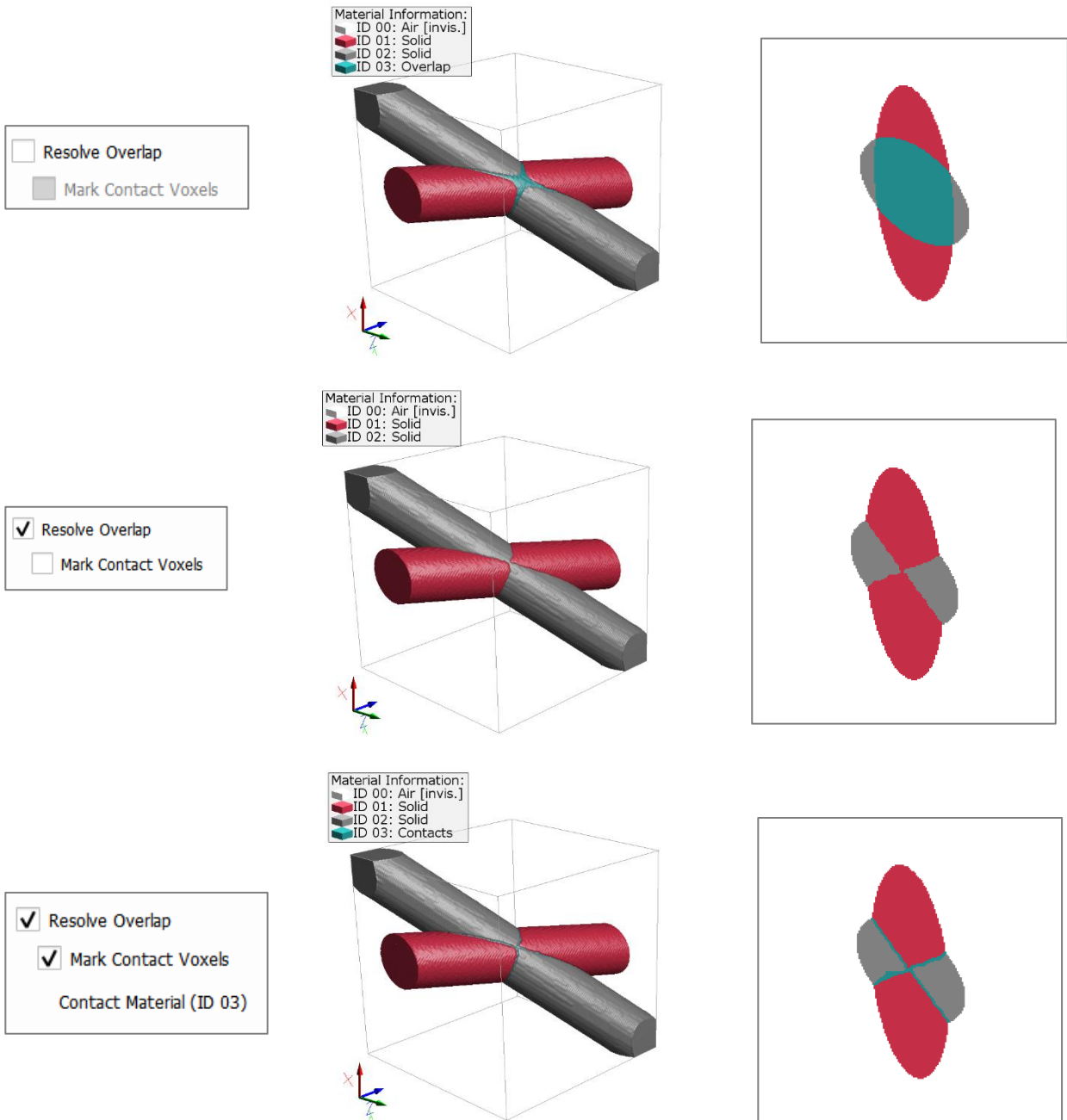

Default Overlap Material defines the default ID of the new material, which will be assigned to the regions where newly generated objects overlap each other and/or the existing structure. When only one object type is present, the overlap material is automatically set to the material of the chosen object type. Furthermore, the material ID is automatically set to the material ID of this object type, when **Material ID per Material** is selected.



The **Number of Overlap Rules** allows to individually define rules for the reassignment of material IDs during overlap operations. In the example shown above, three rules have been defined: The overlap of objects with material ID 1 (red) will be assigned to ID 3 (blue). The overlap of objects with material ID 2 (gray) will be assigned to ID 4 (orange) and the overlap of ID 1 and ID 2 will be assigned to ID 5 (magenta).

Number of Overlap Rules			3
	Material ID 1	Material ID 2	Overlap Material ID
1	01 Manual (Solid)	01 Manual (Solid)	03 Manual (Solid)
2	02 Manual (Solid)	02 Manual (Solid)	04 Solid
3	01 Manual (Solid)	02 Manual (Solid)	05 Solid

Note, that the results for volume in the resulting report do not change for different overlap rules, as the values are computed before the overlap rules are applied. For the values in the result file, the GAD objects are considered, while for the final voxel structure the overlap is handled according to the overlap rules defined in the **Object Overlap** tab.

In the three examples given for **Resolve Overlap**, the **Absolute Object Distribution** is shown here.

Absolute object distribution:		
	Count	Volume / (%)
Total	realized: 2 target: 2 error: 0.00	realized: 11.09 target: --- error: ---
Object type 1	realized: 1 target: 1 error: 0.00	realized: 4.42 target: --- error: ---
Object type 2	realized: 1 target: 1 error: 0.00	realized: 6.68 target: --- error: ---

For the volume percentages of the final structure, refer to the **Statistics** tab above of the visualization area in the **GeoDict** GUI.

Here, the volume statistics are shown for the example with default overlap rules. The red fiber has 3.55% of the volume, the gray fiber has 5.81%, and the overlap 1.73%.

In the result file, the overlap volume is proportionally added to the volume of the overlapping fibers.

Here, the red fiber obtains $3.55\% + (1.73/2)\% = 4.415\%$. Rounded, this results in the 4.42 % shown in the report.

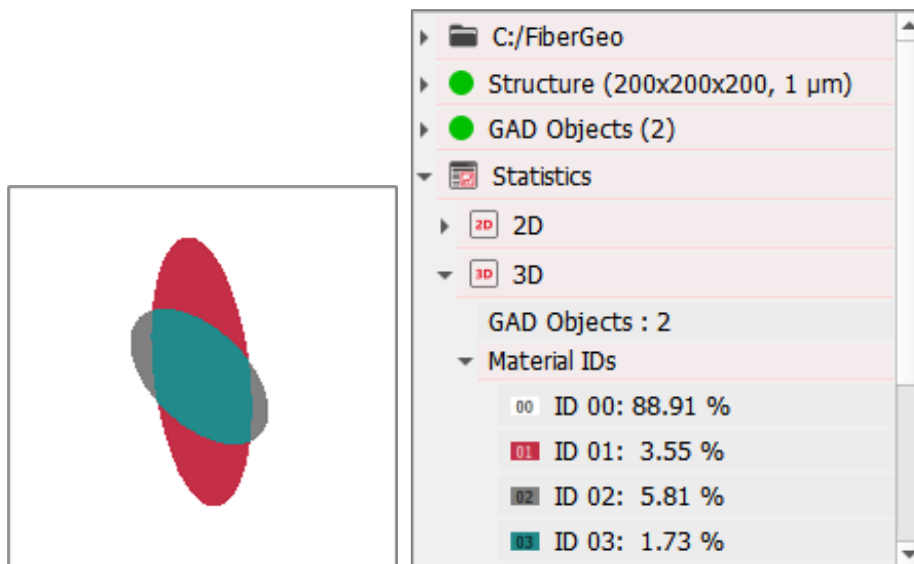

RESULT OPTIONS

GrainGeo always saves the generated structure as a GeoDict structure file (*.gdt) (GeoDict binary data). The file is placed in an automatically created result folder inside the chosen project folder (**File** → **Choose Project Folder...** in the menu bar).

The result file as well as the result folder take the name entered as **Result File Name (*.gdr)** at the bottom of the dialog.

An additional option to save the generated structure data is to check **Save Intermediate Result every** and enter a number of **Objects** in the box. As objects are added to the structure during the generation, an intermediate result file is saved every time the number of placed objects reaches the entered value.

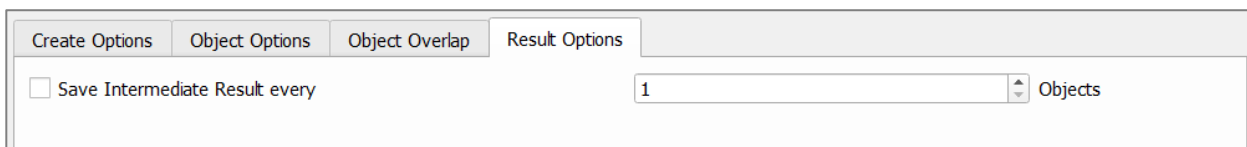

This option may be interesting when studying the properties of a series of structures with increasing density.

After running the generation, the intermediate geometries can be found as *.gad analytic files in the result folder and can be loaded directly from the Result Viewer of the *.gdr result file.

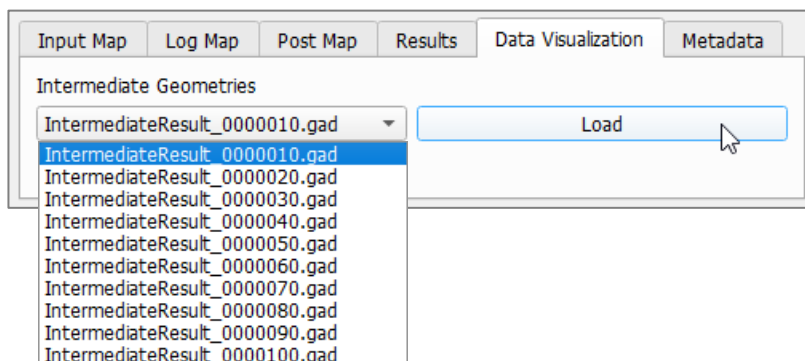

The parameters entered in the **GrainGeo Create Options** dialog can be saved into *.gps (GPS, GeoDict Project Settings) files and/or loaded from them. Remember to restore and reset your (or GeoDict's) default values through the icons at the bottom of the dialog when needed and/or before every GrainGeo run.

Resting the mouse pointer over an icon prompts a Tooltip showing the icon's function to appear.



PILE GRAINS

When choosing **Pile Grains** from the pull-down menu in the **GrainGeo** section, objects fall from their initial positions during the structure's generation and form a piled granular structure.

Clicking the **Options' Edit...** button opens the **GrainGeo Pile Options** dialog.

When the desired parameters have been entered, clicking **OK** closes the dialog and returns to the **GrainGeo** section. There, clicking **Generate** starts the piling process.

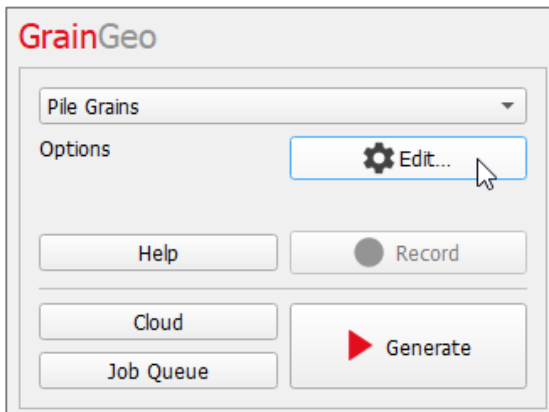

At the top left of the **GrainGeo Pile Options** dialog, the name for the files containing the generation results can be entered in the **Result File Name (*.gdr)** box. The default name can be kept, or a new name can be chosen fitting the current project.

The available units (**m**, **mm**, **µm**, **nm**, and **Voxel**) are selectable at the top right of the dialog. When the units are changed, the entered values are adjusted automatically.

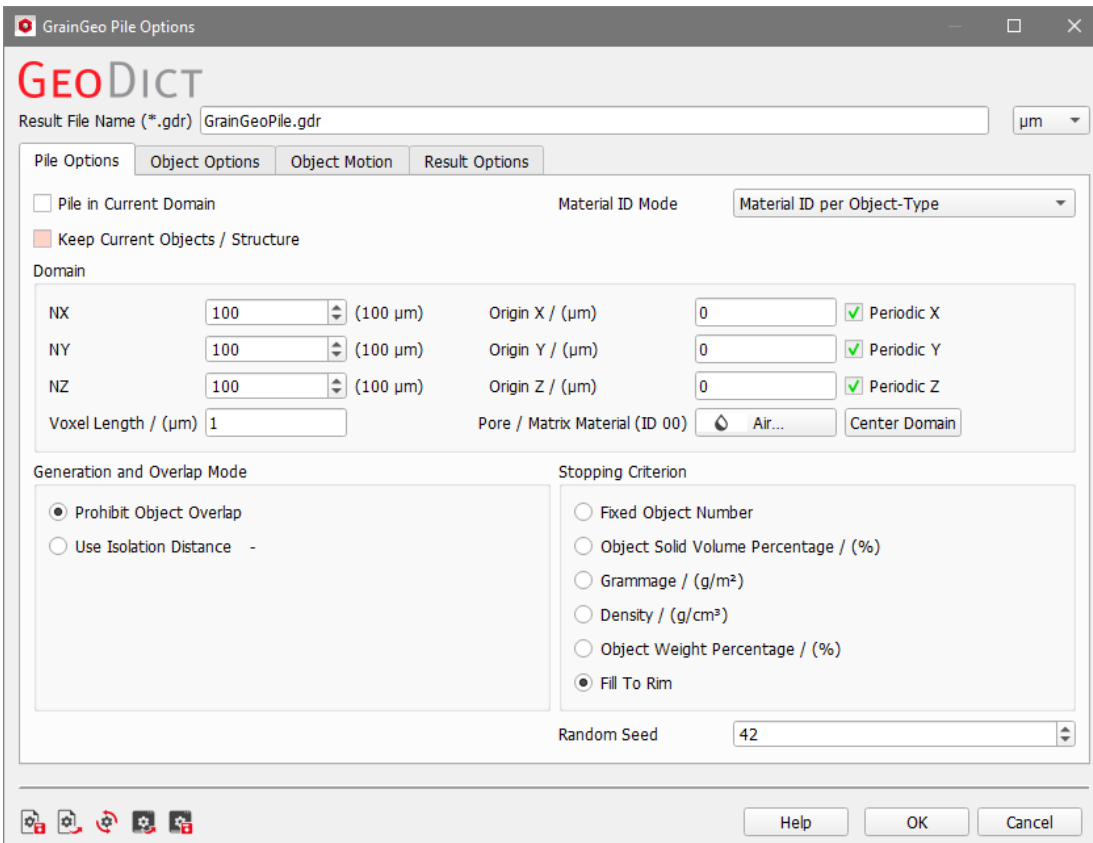

The **Pile Options** are organized under four tabs:

- **Pile Options:** Determine physical properties of the resulting structure model such as size, resolution, overlapping mode, and solid volume percentage.
- **Object Options:** Define the geometrical properties of individual object types such as cross-section, length, and orientation. Up to 254 different object types can be used in one structure.
- **Object Motion:** Controls the way the objects are piled. This is done by defining e.g. different step parameters and the initial object position.
- **Result Options:** Determine how the result files are saved.

PILE OPTIONS

The parameters defining the general properties of the granular structure are entered under the **Pile Options** tab. They are grouped into **Domain**, **Generation and Overlap Mode**, and **Stopping Criterion** panels.

The screenshot shows the 'Pile Options' tab in the GrainGeo software. At the top, there are four tabs: 'Pile Options', 'Object Options', 'Object Motion', and 'Result Options'. The 'Pile Options' tab is active. Below the tabs, there are two checkboxes: 'Pile in Current Domain' (unchecked) and 'Keep Current Objects / Structure' (checked). A red box highlights these two checkboxes. To the right of these checkboxes is a 'Material ID Mode' dropdown menu set to 'Material ID per Object-Type'. Below this is the 'Domain' panel, which contains several input fields: 'NX' (100 μm), 'NY' (100 μm), 'NZ' (100 μm), and 'Voxel Length / (μm)' (1). There are also 'Origin X / (μm)', 'Origin Y / (μm)', and 'Origin Z / (μm)' fields, all set to 0. To the right of these are three checked checkboxes: 'Periodic X', 'Periodic Y', and 'Periodic Z'. Below the 'Domain' panel is the 'Generation and Overlap Mode' panel, which has two radio buttons: 'Prohibit Object Overlap' (selected) and 'Use Isolation Distance'. To the right of this is the 'Stopping Criterion' panel, which has five radio buttons: 'Fixed Object Number', 'Object Solid Volume Percentage / (%)', 'Grammage / (g/m²)', 'Density / (g/cm³)', and 'Object Weight Percentage / (%)'. The 'Fill To Rim' radio button is selected. At the bottom right, there is a 'Random Seed' field set to 42.

PILE IN CURRENT DOMAIN AND KEEP CURRENT OBJECTS / STRUCTURE

When checking **Pile in Current Domain**, the structure currently in memory, is taken as domain for piling a new structure. Additionally, when **Keep Current Objects / Structure** is checked, the structure in memory is kept and combined with the newly piled structure, otherwise it is discarded after the piling step. Piled grains will not overlap.

Notice that the size parameters, grouped under the **Domain** panel, cannot be modified when **Pile in Current Domain** is checked, because they are kept from the structure already in memory.

Observe the effect that checking or leaving un-checked **Pile in Current Domain** and **Keep Current Objects / Structure** has on the generation of a piled granular structure.

A structure composed of ellipsoids is already in memory when spheres fall from the Z+ direction.

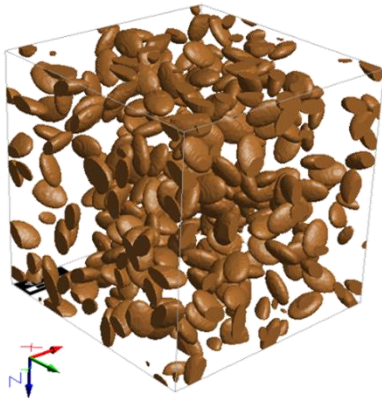

When piling on the copper ellipsoids (current structure), the steel spheres fall on the copper ellipsoids, and some do not reach the bottom. When not piling on the copper ellipsoids (current structure), the steel spheres fall all the way to the bottom of the domain.

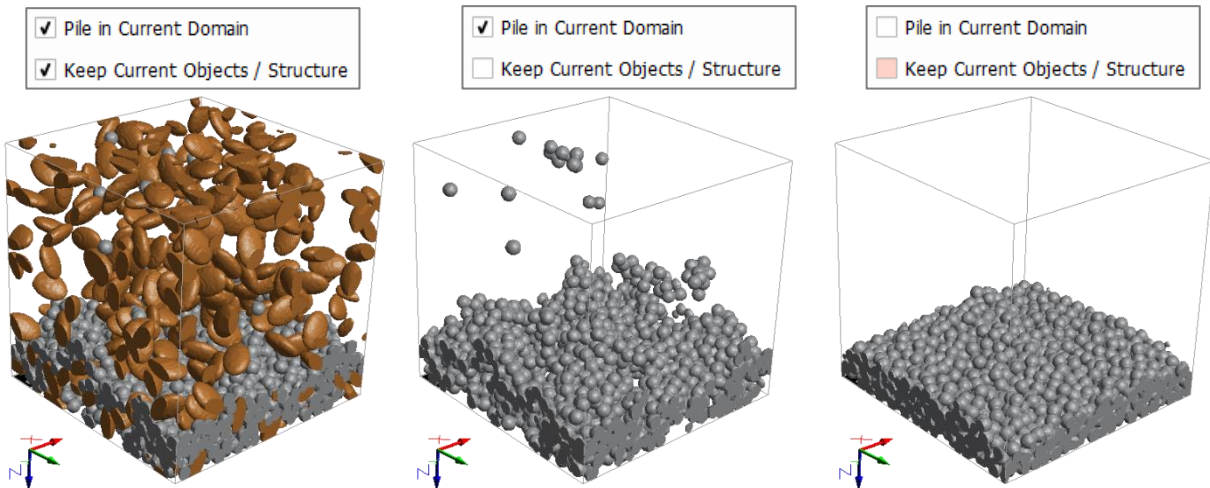

DOMAIN

The **Domain** panel contains the parameters defining the structure size (**NX**, **NY**, and **NZ**) in combination with the resolution (**Voxel Length**), as well as the **Origin** parameters, **Center Domain**, and the **Periodicity** checkboxes. The periodicity boxes are disabled (and checked) for **Pile**, because the objects are always piled periodically.

Domain					
NX	<input type="text" value="100"/> (100 μm)	Origin X / (μm)	<input type="text" value="0"/>	<input checked="" type="checkbox"/> Periodic X	
NY	<input type="text" value="100"/> (100 μm)	Origin Y / (μm)	<input type="text" value="0"/>	<input checked="" type="checkbox"/> Periodic Y	
NZ	<input type="text" value="100"/> (100 μm)	Origin Z / (μm)	<input type="text" value="0"/>	<input checked="" type="checkbox"/> Periodic Z	
Voxel Length / (μm)	<input type="text" value="1"/>	Pore / Matrix Material (ID 00)	<input type="text" value="Air..."/>	<input type="button" value="Center Domain"/>	

NX, NY, NZ, and Voxel Length

The internal representation of a structure in **GeoDict** consists of rectangular 3D arrays of equally sized boxes, hereafter called volume elements or **voxels**. **NX**, **NY**, and **NZ** are the number (N) of voxels in X, Y and Z directions.

The **Voxel Length** is the size of one voxel in the chosen units. Varying the values for **NX**, **NY**, and **NZ** has the effect of changing the size of the piled structure in the given direction.

NX	<input type="text" value="200"/>	200 μm
NY	<input type="text" value="200"/>	200 μm
NZ	<input type="text" value="200"/>	200 μm
Voxel Length / (μm)	<input type="text" value="1"/>	

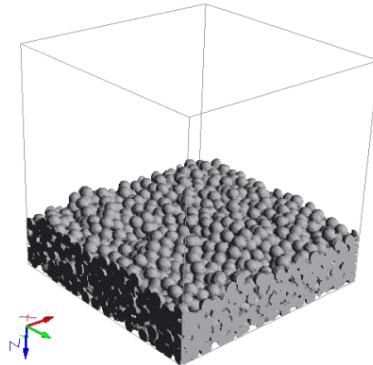

Low values for voxel length in combination with high values for **NX**, **NY** and **NZ** result in a higher resolution, but also in a higher computational time. After setting the values of **NX**, **NY**, and **NZ**, and **Voxel Length**, the physical structure size is automatically displayed in the chosen units.

NX	<input type="text" value="300"/>	300 μm
NY	<input type="text" value="200"/>	200 μm
NZ	<input type="text" value="200"/>	200 μm
Voxel Length / (μm)	<input type="text" value="1"/>	

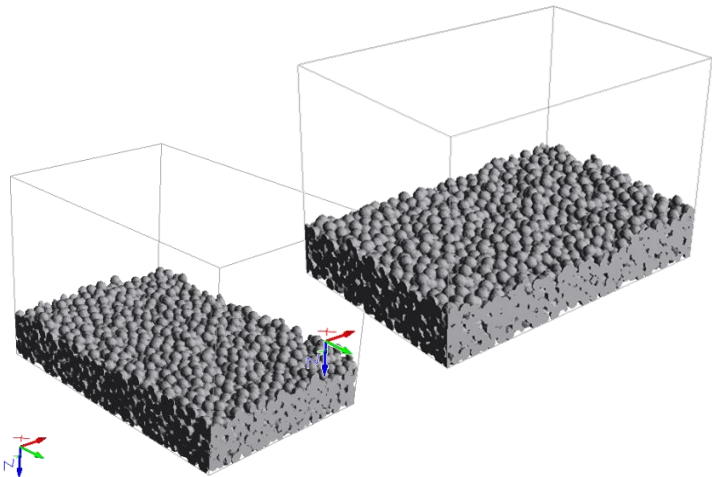

NX	<input type="text" value="200"/>	200 μm
NY	<input type="text" value="300"/>	300 μm
NZ	<input type="text" value="200"/>	200 μm
Voxel Length / (μm)	<input type="text" value="1"/>	

Observe how keeping the structure size a constant $100 \times 100 \times 100 \mu\text{m}^3$ while decreasing the **Voxel Length** from $0.5 \mu\text{m}$ to $0.25 \mu\text{m}$ has the effect of refining the spheres in the pile by increasing the resolution. Since the voxel length has decreased to half, the size of the structure is kept by doubling the **NX**, **NY**, and **NZ** values from 200 to 400.

NX	<input type="text" value="200"/>	100 μm
NY	<input type="text" value="200"/>	100 μm
NZ	<input type="text" value="200"/>	100 μm
Voxel Length / (μm)	<input type="text" value="0.5"/>	

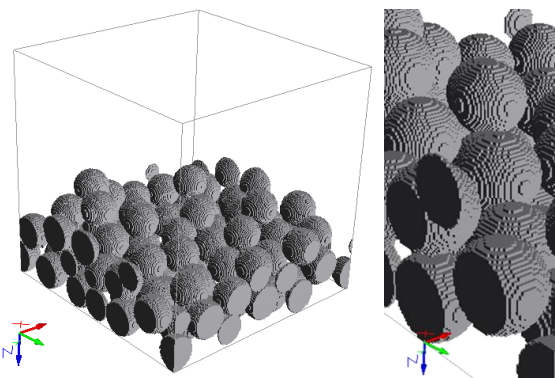

NX	<input type="text" value="400"/>	100 μm
NY	<input type="text" value="400"/>	100 μm
NZ	<input type="text" value="400"/>	100 μm
Voxel Length / (μm)	<input type="text" value="0.25"/>	

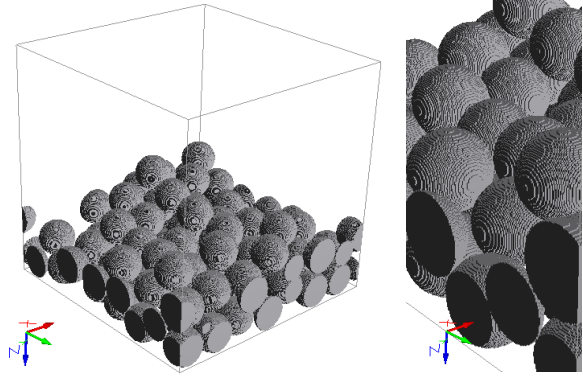

Origin X, Origin Y, and Origin Z, and Center Domain

The **Origin X**, **Origin Y**, and **Origin Z** parameters, together with the **Center Domain** button, determine the placement of the piled structure in the physical space in the same way as seen above for **GrainGeo – Create Grains** (page 8).

GENERATION AND OVERLAP MODE

The options in the **Generation and Overlap Mode** panel control the relative position among objects (or with the structure currently in memory).

Objects may touch (but not overlap) when **Prohibit Objects Overlap** is selected. Objects may not touch when **Use Isolation Distance** is selected, and a positive value is entered. Then, all objects have at least this preset distance. The choice of **Use Isolation Distance** may lead to long computation times for large structures. In contrast to **Create Grains**, negative values for the **Isolation Distance** are not allowed.

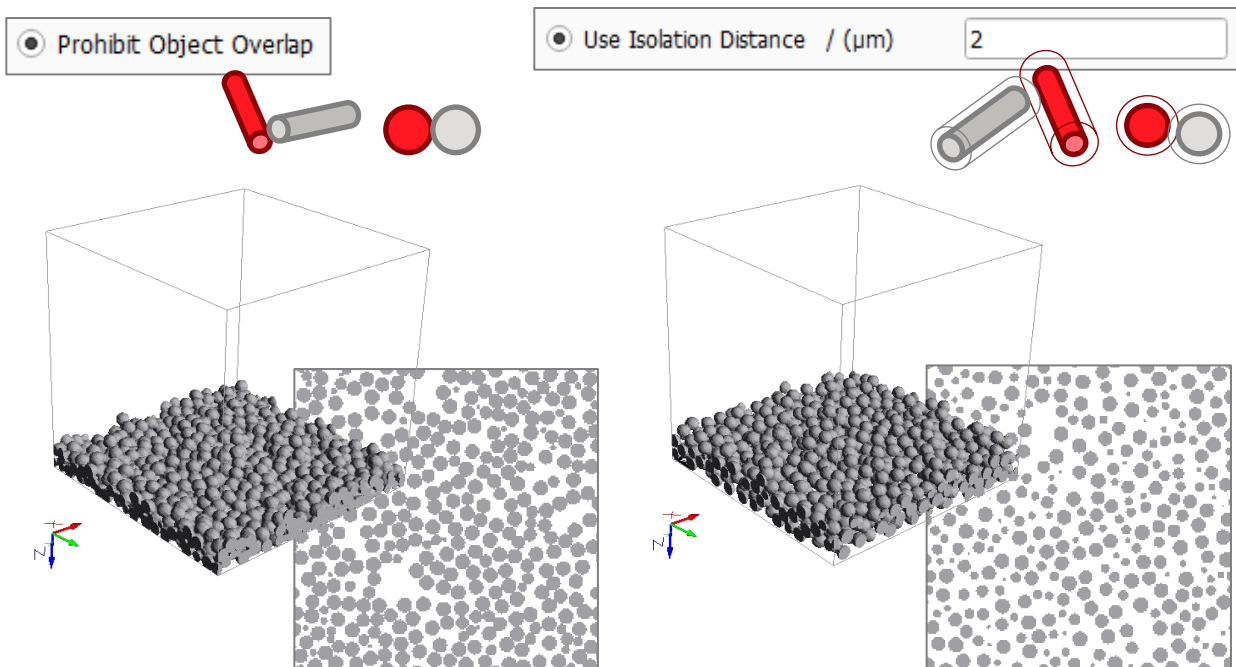

STOPPING CRITERION

The parameters in the **Stopping Criterion** panel control the criteria which stop the piling process. The analysis of the results file (GDR file) shows any disparity between the achieved result values and the desired ones.

Besides the same options available for **GrainGeo – Create Grains** (pages 22ff.), it is also possible to choose **Fill to Rim**.

Stopping Criterion

- Fixed Object Number
- Object Solid Volume Percentage / (%)
- Grammage / (g/m²)
- Density / (g/cm³)
- Object Weight Percentage / (%)
- Fill To Rim

Fill to Rim

Fill to Rim continues the piling process until the objects reach the top of the bounding box in the Z-direction.

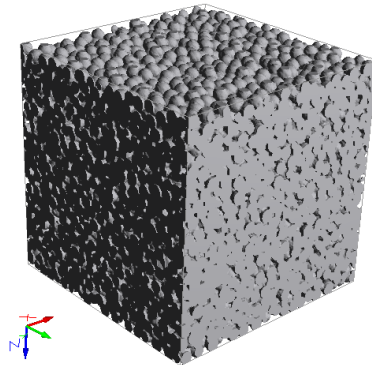

RANDOM SEED

Random Seed initializes the random number generator used by the structure generator. Changing its value produces different sequences of random numbers and hence, different realizations of the specified structure. If all settings are equal, generating with the same **Random Seed** value produces an identical structure. **Random Seed** is a non-negative integer number.

Varying the **Random Seed** allows generating different samples of the same granular structure. In the following examples, all parameters are unchanged while the Random Seed is changed (here: 6, 22, 55).

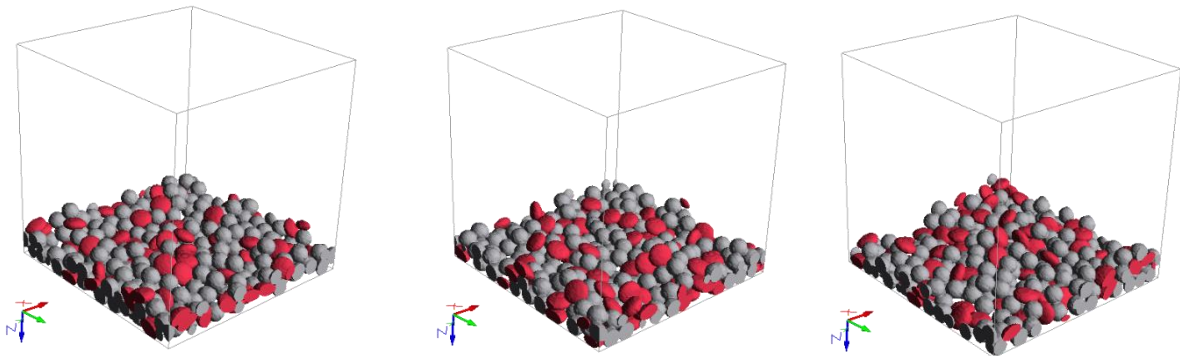

OBJECT OPTIONS

The objects available to pile granular structures (**Pile**) are organized and listed in panels in a way almost identical to the one for creating granular structures (**Create**). See the detailed explanations above, page [26ff.](#) Up to 254 different object types may be added to the same structure.

The center position of the objects is a result of the piling process and cannot be specified.

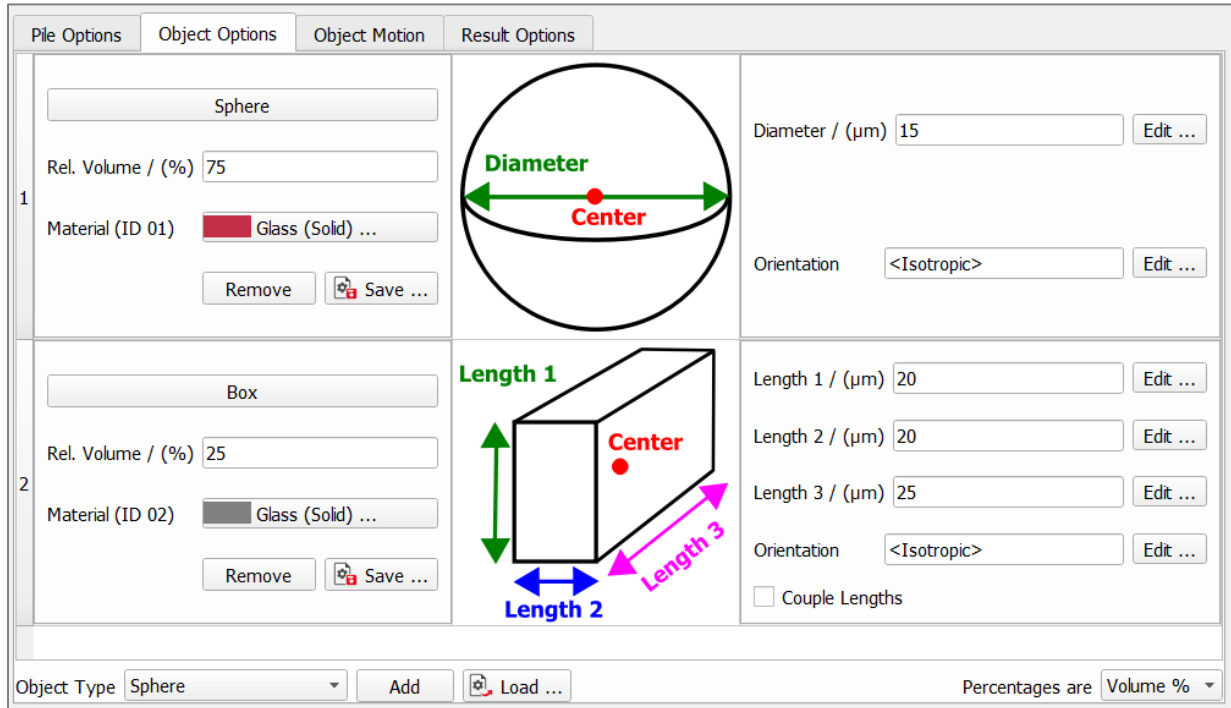

OBJECT MOTION

The **Object Motion** parameters control the objects' movement and initial position during the piling process, and are grouped into the **Piling Step**, and the **Object Position** panels. The **Pile Mode** can be selected from the pull-down menu.

PILING STEP

The object movement during the piling process is mainly defined by the falling **Direction** and by the automated finding of a stable minimum (**Find Stable Minimum**).

When the result is unsatisfactory, additional parameters can be used to refine it (**Number of Shifts**, **Maximum Shift Angle**, **Number of Rotations** per shift, **Maximum Rotation Angle** and **Maximum Check Length**).

Find Stable Minimum is not available when all objects fall at the same time (Pile Mode → All Objects at Once). **Maximum Check Length** is only available if **Find Stable Minimum** is checked.

Direction

The direction in which the piling process happens can be chosen from the pull-down menu. For all three axes, the objects fall towards the positive direction (X+, Y+, or Z+). Observe the piling of spheres with **On Inflow Plane Center** as initial object position, falling from all three directions.

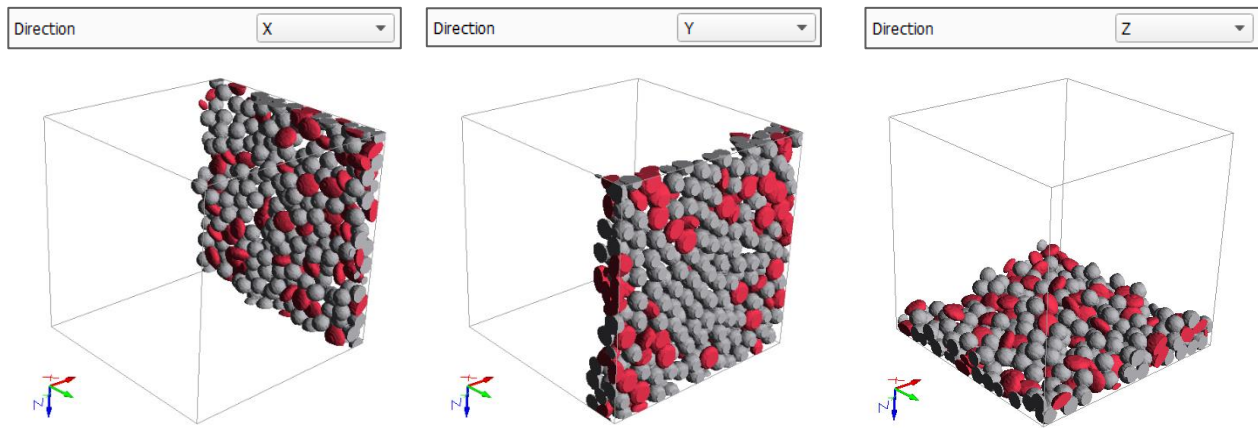

Number of Shifts, Maximum Shift Angle, Number of Rotations, Maximum Rotation Angle

Throughout the piling process, the objects fall in the specified direction and roll to their final location in the granular structure. After the fall, i.e. after hitting an obstacle as the bottom domain boundary or another object, the objects shift and rotate as many times as defined by the values for **Number of Shifts** and **Number of Rotations** before they come to rest at the bottom of the structure. Low values for shifts and rotations produce structures with objects that settle earlier compared to larger values of these parameters, resulting in a lower packing density.

In detail, the algorithm for each shift tries the given number of rotations. If a better position is found for the object, lower in the specified direction and without overlapping with other objects, it is used as a new point for the object. Then, the numbers of shift and rotation are reset. The algorithm terminates if no new position is found for the given number of shifts and rotations.

Observe the effect of setting a low or a high **Number of Shifts** value on the final position of ellipsoids in a piled structure.

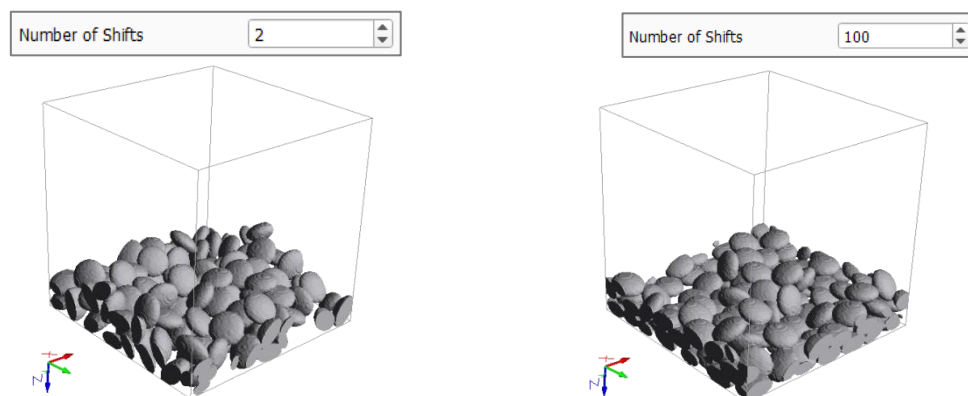

The **Maximum Shift Angle** restricts the angle that the objects can shift with respect to the piling direction. Thus, the object always moves downwards.

The **Maximum Rotation Angle** describes the maximum angle the objects can rotate from step to step. The object is rotated around the center defined for the object, which in most cases is the center of mass. Spheres are not rotated, as it would not have any effect on the results.

Find Stable Minimum and Maximum Check Length

When checking **Find Stable Minimum**, each object is checked to have a stable state with respect to gravity at the end of the piling process. The position of an object is considered as unstable, if it is possible to move it vertically (perpendicular to the specified direction) without obtaining overlap with other objects, i.e. it does not have the lowest position possible.

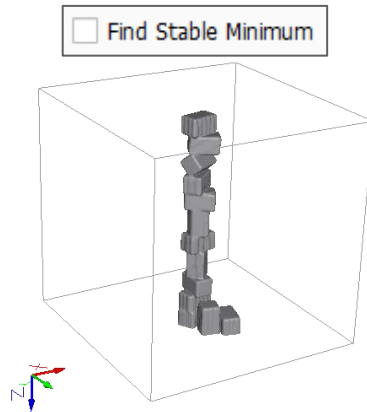

The **Maximum Check Length** is a further refinement when finding the stable minimum. For every object, the algorithm checks for an even more stable position around the already reached minimum with a radius defined by the voxel value entered in the field. A higher value increases the stability of the pile.

Observe the effect of checking or un-checking **Find Stable Minimum**, and then entering increasing values of **Maximum Check Length** (1, 3, and 10) in the piling of 100 boxes with initial object position **On Inflow Plane Center**.

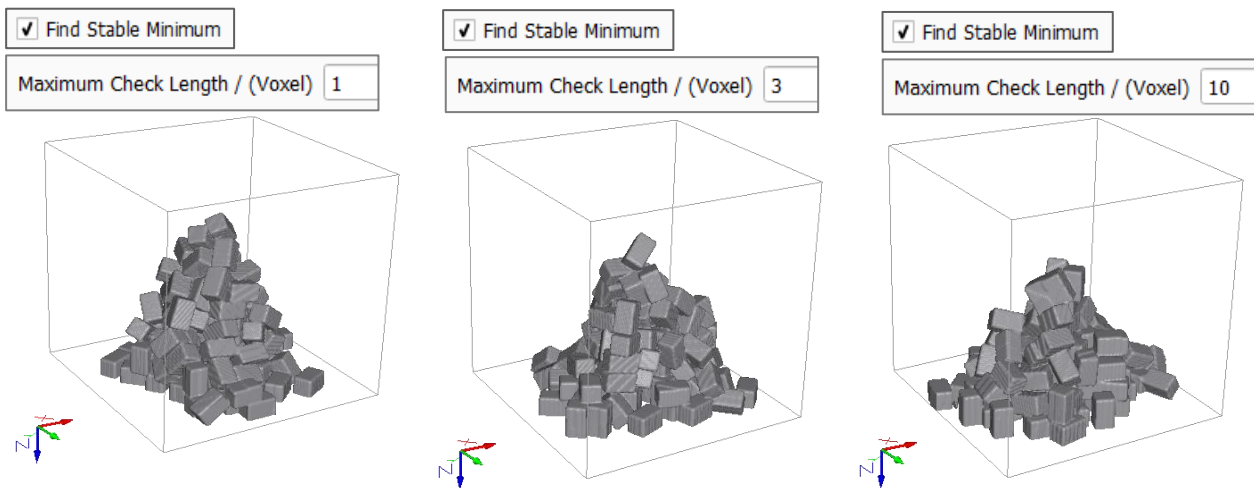

While it is faster to pile structures when **Find Stable Minimum** is un-checked, the resulting packing densities are lower.

Observe the change in realized **Volume [%]** value (shown in the result file under the Results Info tab) when **Find Stable Minimum** is checked or un-checked, if all other parameters stay the same, including Random Seed. The initial object position is **On Inflow Plane**, and **Fill To Rim** is the stopping criterion. The final structures look similar, but the realized solid volume percentages differ significantly.

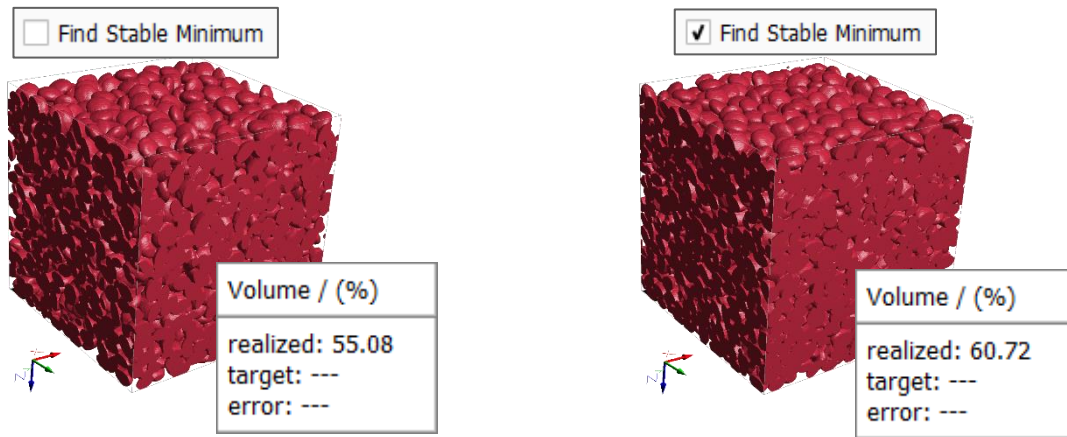

PILE MODE AND OBJECT POSITIONS

Select from the pull-down menu whether the objects should fall one after another (**Object after Object**) or all should fall at once (**All Objects at Once**).

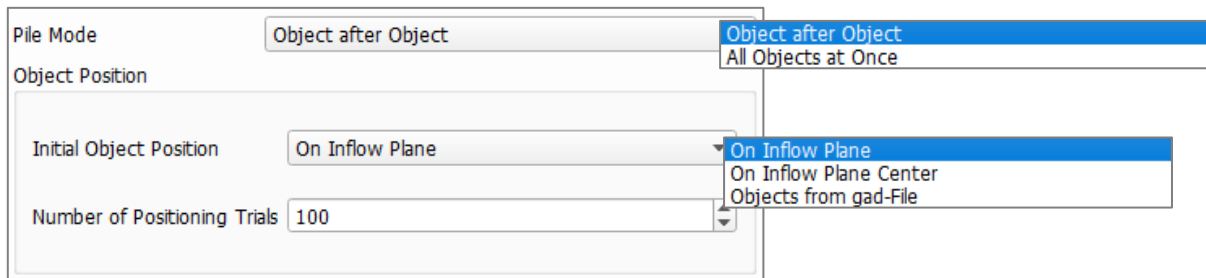

When choosing **Object after Object**, the pull-down menu allows setting the initial position from which the objects are set to fall: From initial position plane (**On Inflow Plane**), from its center (**On Inflow Plane Center**), or from an existing structure (**Objects from gad File**).

When piling objects **On Inflow Plane** or **On Inflow Plane Center**, and to increase the quality of the piled structure, the **Maximal Number of Positioning Trials** can be adjusted at the cost of additional runtime.

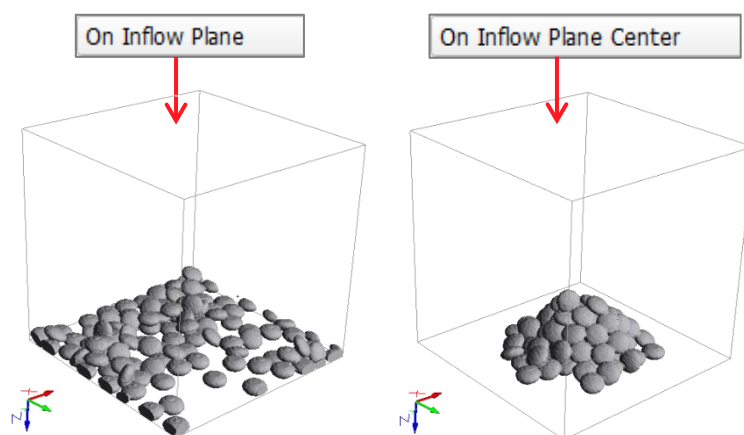

When piling from an existing structure, the objects are those already in the structure and no objects (and their geometry parameters) need to be selected through the **Object Options** tab.

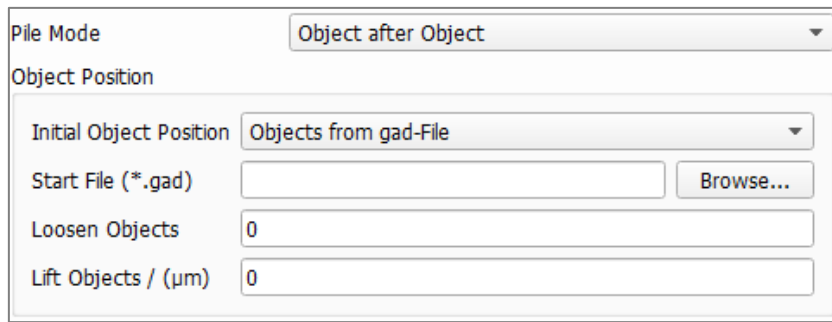

Clicking **Browse**, a structure saved in GAD format can be selected as the source of the objects.

When choosing **All Objects at Once**, the objects can only originate from the analytic data of an existing structure.

Structures in GAD format to be used for piling must conform to certain requirements (no overlapping, periodicity, no objects crossing bottom plate) and should be generated for later piling with these requirements in mind. Overlap can be removed after generation using GadGeo → Remove Object Overlap.

Assuming the Z-direction to be the piling direction, and downwards to be the positive direction (Z+), the following situations should be considered:

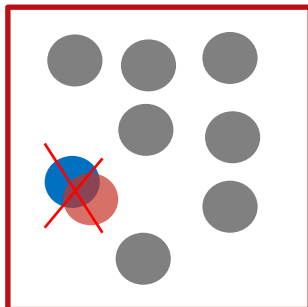

Touching, but not overlapping, is allowed for piling. The initial structure must be generated without overlapping. For example, by selecting **Remove Overlap** when generating with GrainGeo → **Create** (or other GeoDict generators).

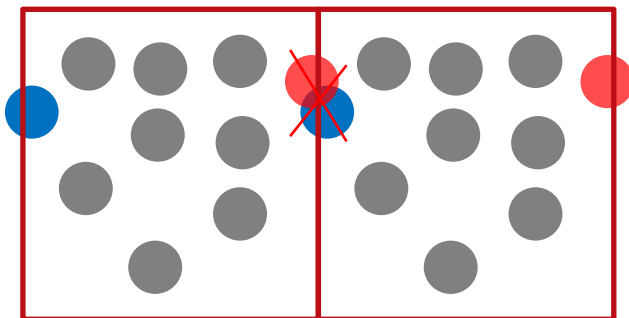

Periodicity is needed in the X and Y directions for piling, to avoid undesired intersections at the edge of the structure. The initial GAD file must be generated to be periodic (in all directions).

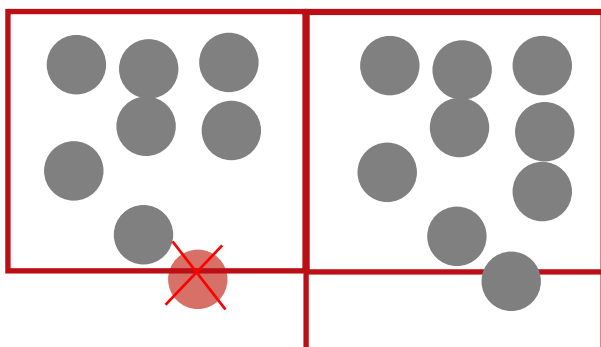

Objects are not allowed to drop off the bottom of the structure. When this happens, the dimensions of the initial *gad file must be processed to include the extruding object.

This can be done by adding enough empty voxels in Z+ direction by using **Model** → **ProcessGeo** → **Process** → **Embed** (check **Embed Analytic Objects** to keep the GAD format) or by increasing the size of the domain in Z-direction **Model** → **GadGeo** → **Edit Domain**.

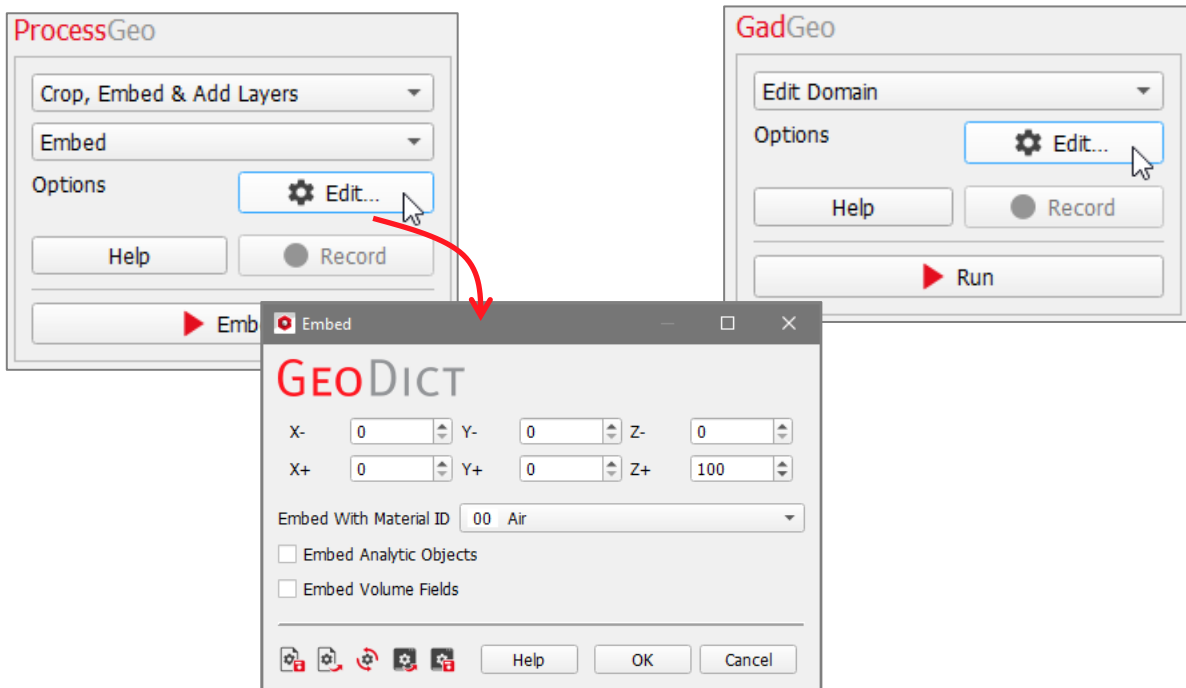

The number of voxels to be added depends on how far objects overlap the original domain in z-direction.

Before piling, the domain size in the Z-direction under the **Pile Options** tab – **Domain** panel must be increased to adjust to the larger domain size of the modified GAD file.

For example:

Domain			Domain		
NX	200	200 μm	NX	200	200 μm
NY	200	200 μm	NY	200	200 μm
NZ	200	200 μm	NZ	300	300 μm

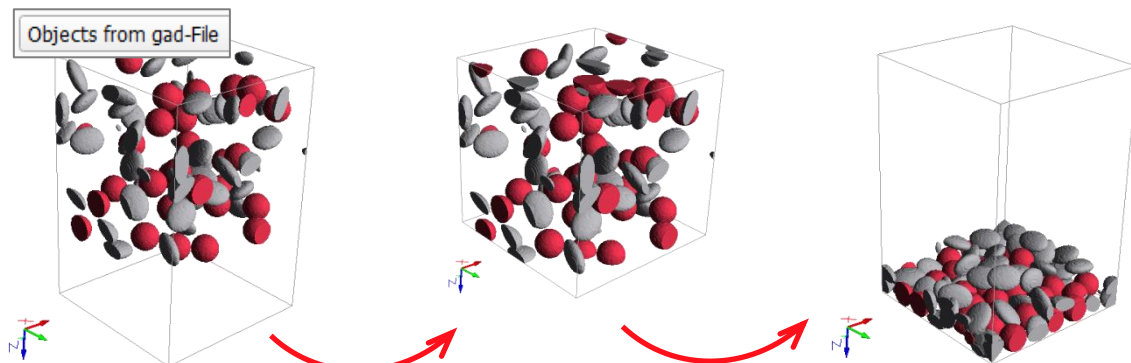

Before the piling process starts from a structure in GAD-format, the position of the objects it will contain can be slightly modified by two parameters. The distance between the objects in the piling direction can be enlarged by the factor entered in **Loosen Objects**. Additionally, all objects can be lifted by the distance entered in **Lift Objects**. For example, these parameters can be used to generate structures similar to those from sieving processes combined with additional shaking.

RESULT OPTIONS

The pile **Result Options** on managing the saving of result and geometry files are completely analogous to the create **Result Options** explained above (page [68](#)).

PACK ANALYTIC SPHERES

When choosing **Pack Analytic Spheres** from the pull-down menu in the **GrainGeo** section, densely packed spheres are generated. **GeoDict** uses a force-biased algorithm to create the dense packing [1].

The necessary parameters can be entered in the **GrainGeo - Pack Options** dialog, after clicking the **Options' Edit...** button. When the desired parameters have been entered in the **Pack Analytic Spheres** dialog, clicking **OK** closes the dialog and returns to the **GrainGeo** section. There, clicking **Generate** starts the process.

A **Result File Name (*.gdr)** should be entered to differentiate the results of every run of previous computations. The GDR (GeoDict result) files contain complete information on packing parameters, achieved packing density, and packing process file names.

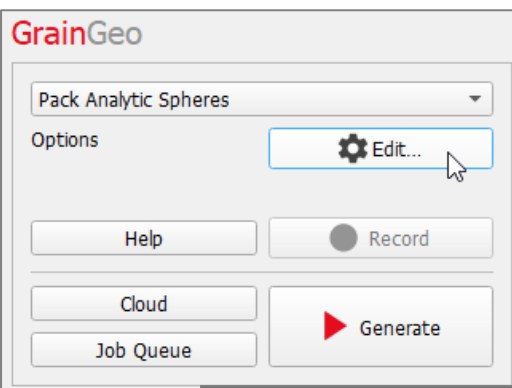

The available **units** (m, mm and μm) are selectable from the pull-down menu.

The parameters for the packing process are organized in two tabs: **Pack Options** and **Sphere Distribution**.

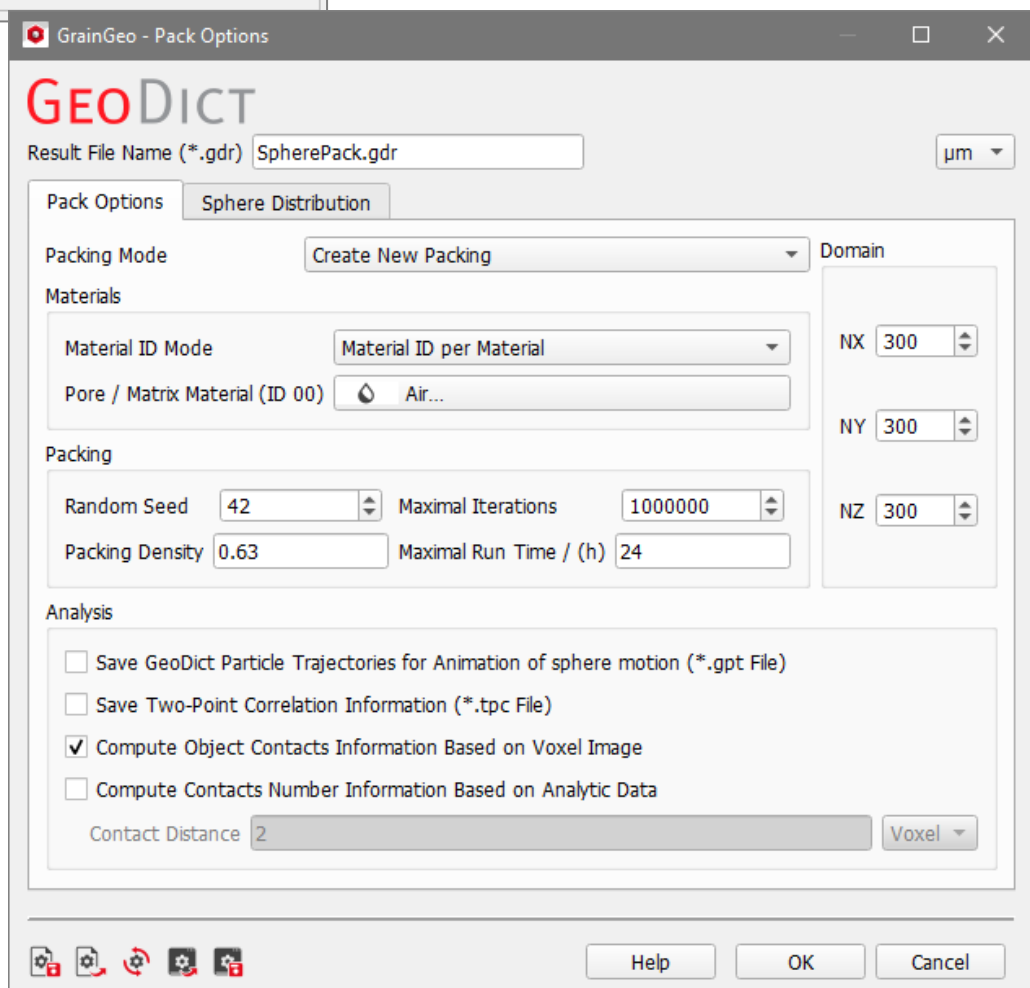

The general properties of the packed structure are entered under the **Pack Options** tab. These parameters are grouped into the panels **Domain**, **Materials**, **Packing**, and **Analysis**.

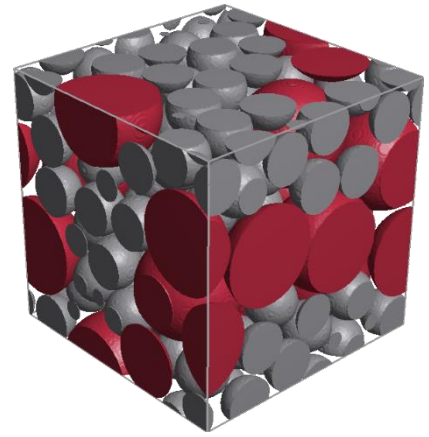

In the **Domain** panel, enter the values for **NX**, **NY** and **NZ**, indicating the number of voxels that the packed structure should have in the **X**, **Y**, and **Z**-direction, respectively.

Change **NX**, **NY** and **NZ** by direct insertion or by clicking the arrow buttons.

From the Packing Mode pull-down menu, select to **Create New Packing** or to **Re-Compact Existing Packing**.

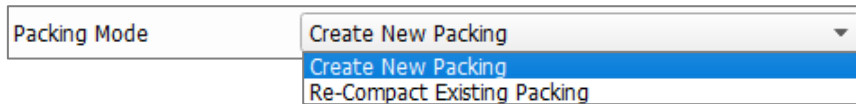

Choosing to re-compact an existing packing enables to **Browse** and load the GDR result file from a previously run packing process. This **GeoDict** result file, and corresponding result folder, already include the packing parameters.

CREATE NEW PACKING

The spheres are packed into a new structure. The available parameters for the generation are listed and explained below.

PACK OPTIONS

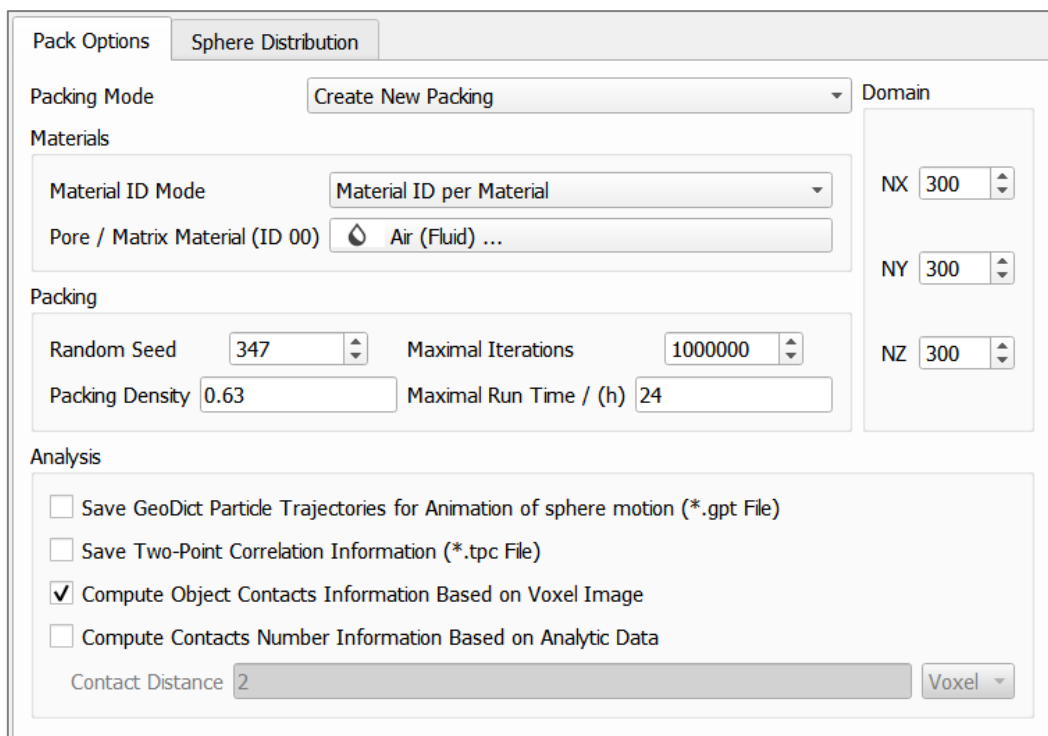

The screenshot shows the 'Pack Options' dialog box with the 'Sphere Distribution' tab selected. The 'Packing Mode' is set to 'Create New Packing'. The 'Materials' section shows 'Material ID Mode' as 'Material ID per Material' and 'Pore / Matrix Material (ID 00)' as 'Air (Fluid) ...'. The 'Packing' section includes 'Random Seed' (347), 'Maximal Iterations' (1000000), 'Packing Density' (0.63), and 'Maximal Run Time / (h)' (24). The 'Domain' section shows 'NX' (300), 'NY' (300), and 'NZ' (300). The 'Analysis' section has four checkboxes: 'Save GeoDict Partide Trajectories for Animation of sphere motion (*.gpt File)' (unchecked), 'Save Two-Point Correlation Information (*.tpc File)' (unchecked), 'Compute Object Contacts Information Based on Voxel Image' (checked), and 'Compute Contacts Number Information Based on Analytic Data' (unchecked). The 'Contact Distance' is set to 2, with a 'Voxel' dropdown menu.

 Materials

Material ID Mode: The pull-down menu allows selecting between applying the Material ID based on the materials or the types of objects present in the packed structure. Changing from the default **Material ID per Material** to **Material ID per Object-Type** allows assigning a Material ID to the spheres based on their size (diameter). This is part of the **GeoDict** Material Database concept, in which objects in the structure are ascribed to an individual material (e.g. glass, iron, PET) with specific physical properties.

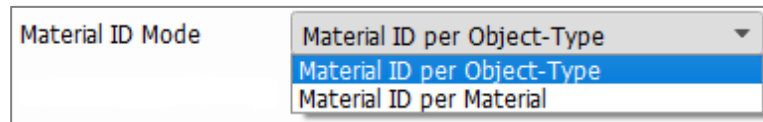

By clicking the button to the right of **Pore/Matrix Material (ID 00)**, it is possible to change the material ID assigned to the pore space/matrix surrounding the objects in the structure from the default Air (Fluid) to any other material.

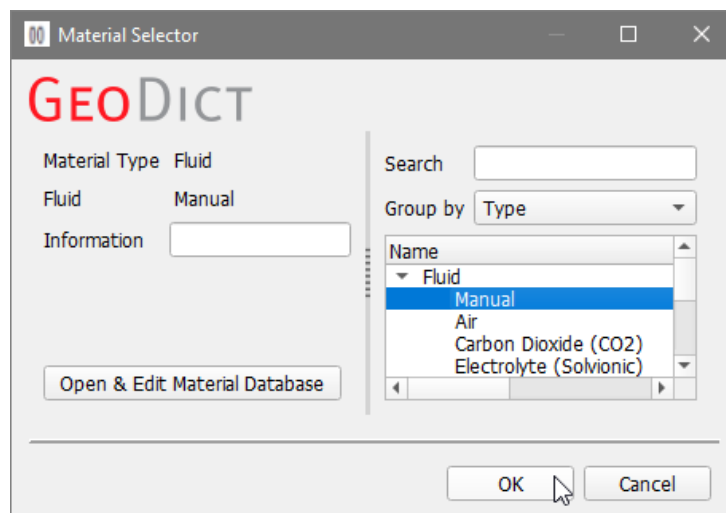
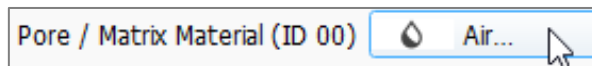

 Packing

The **Random Seed** is a non-negative integer number that defines the random initial position of the spheres. Changing its value produces different sequences of random numbers and, hence, different realizations of the specified structure. If all settings are equal, generating with the same **Random Seed** value produces exactly the same structure.

For **Packing Density** enter values between 0 and 1 (0% to 100% packing density). The parameter **Maximal Iterations** allows setting an upper limit to the number of steps for the packing process.

The **Maximal Run time (h)** permits setting the upper time limit for the packing process.

Analysis

Checking the boxes **Save GeoDict Particle Trajectories for Animation of sphere motion (*.gpt File)** and **Save Two-Point Correlation Information (*.tpc File)**, creates the respective files inside the results folder in the project folder.

Checking **Save GeoDict Particle Trajectories for Animation of sphere motion (*.gpt File)** creates a file containing the sphere trajectories during the packing process. The particle trajectory file can be loaded for visualization.

Since saving the sphere trajectories results in a significant slowing down of the packing process, while the files are opened and trajectories for every sphere are saved, there is no need to select this option unless knowing the trajectories is essential for the project.

If **Compute Object Contacts Information Based on Voxel Image** is checked, GeoDict counts the number of sphere-to-sphere contacts by checking if a voxel belonging to one sphere is in direct contact with a voxel belonging to another sphere. This is reported as Voxel Contacts under the **Results - Report** subtab of the Result Viewer of the GDR result file, after the packing process has run.

The **Mean Coordination Number** is the mean number of neighboring spheres that any sphere touches. It is computed as $2 \times \frac{\text{Number of Contacts}}{\text{Number of Spheres}}$. Each contact needs to be counted twice, once for each sphere which participates in this contact.

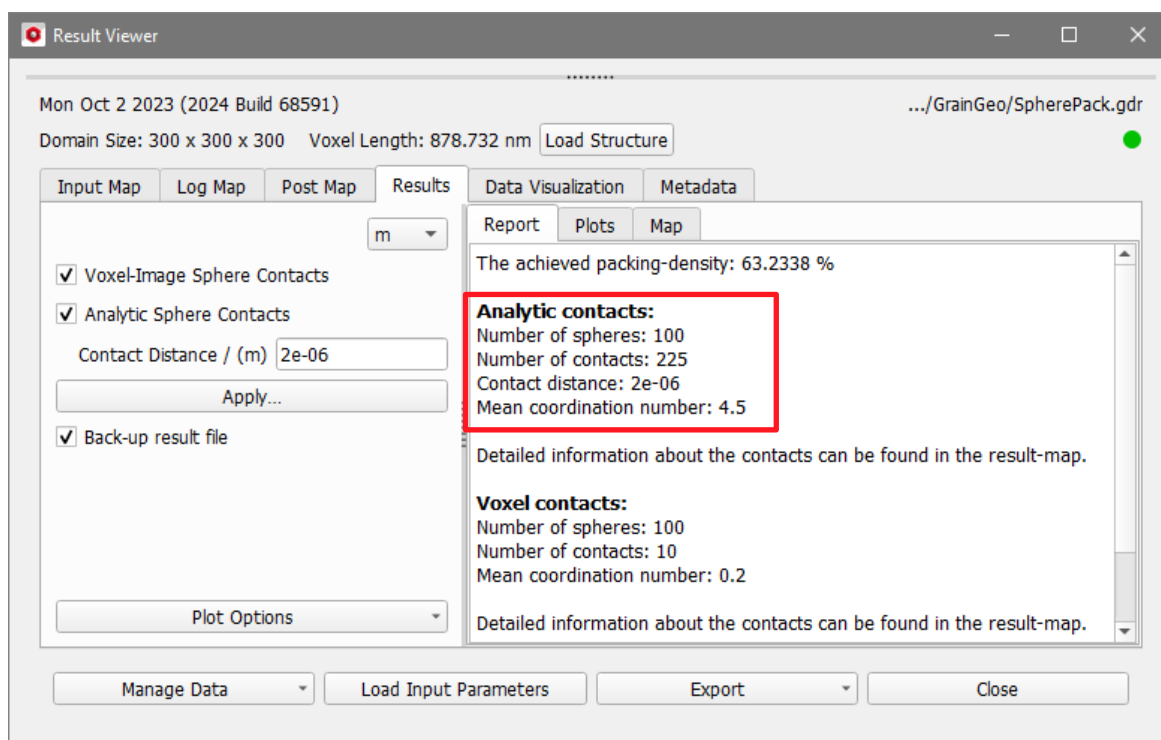

In the **Results - Map** subtab, detailed information on each contact is found. Under the **VoxelContacts** key, the index numbers of the two objects that are in contact with each other, and the number of contacting voxel faces of each contact is shown.

Key	Unit	Value
VoxelLength	m	8.787316322e-07
PackingDensity	1	0.632338
NumberOfSpheres		11, 89
▶ AdditionalFiles		
▶ AnalyticContacts		
▼ VoxelContacts		
NumberOfObjects		100
NumberOfContacts		10
TotalContactFaces		267
MeanCoordinationNumber		0.2
▼ Contacts		
Object1		1, 1, 1, 3, 3, 4, 6, 8, 9, 10
Object2		3, 65, 94, 6, 11, 65, 10, 10, 38, 11
ContactFaces		63, 59, 1, 7, 26, 59, 8, 20, 3, 21

If **Compute Contacts Number Information Based on Analytic Data** is checked, **GeoDict** counts the number of sphere-to-sphere contacts by checking if the distance between the center points of the spheres is large enough. For numerical reasons, it is highly unlikely that two spheres will exactly touch each other. Rather, there will always be a small distance between them.

For example, with a given **Contact Distance** of 0.5 μm , a sphere of diameter 20 μm is defined to be in contact with a sphere of diameter 10 μm , if the distance between their center points is less than 15.5 μm .

The chosen **Contact Distance** can be changed during post-processing. Smaller contact distances lead to less contacts found.

Input Map | Log Map | Post Map | Results | Data Visualization | Metadata

Report | Plots | Map

m

Voxel-Image Sphere Contacts

Analytic Sphere Contacts

Contact Distance / (m)

Apply...

The achieved packing-density: 63.2338 %

Analytic contacts:

Number of spheres: 100
 Number of contacts: 225
 Contact distance: 2e-06
 Mean coordination number: 4.5

Input Map | Log Map | Post Map | Results | Data Visualization | Metadata

Report | Plots | Map

m

Voxel-Image Sphere Contacts

Analytic Sphere Contacts

Contact Distance / (m)

Apply...

The achieved packing-density: 63.2338 %

Analytic contacts:

Number of spheres: 100
 Number of contacts: 33
 Contact distance: 1e-06
 Mean coordination number: 0.66

In the **Results – Map** subtab, detailed information about each contact can be found. Under the **AnalyticContacts** key, the index numbers of the two objects that are in contact with each other are shown.

Key	Unit	Value
VoxelLength	m	8.787316322e-07
PackingDensity	1	0.632338
NumberOfSpheres		11, 89
▶ AdditionalFiles		
▼ AnalyticContacts		
ContactDistance		2e-06
NumberOfObjects		100
NumberOfContacts		225
MeanCoordinationNumber		4.5
▼ Contacts		
Object1		1, 1, 1, 1, 1, 1, 1, 1, 2, 2, 2, 2, 2, 2, 2, 2, 2, 2, 2, 2, ...
Object2		3, 6, 9, 23, 27, 44, 65, 94, 4, 9, 10, 11, 20, 30, 65, 6...
▶ VoxelContacts		

Statistical information saved when packing / piling analytic spheres

Besides the result file, a results folder with the same name is created. In this directory, GrainGeo saves files from the packing or piling run (see below pages 94ff.) in the several formats.

Some of these formats are optional and only saved if the corresponding checkbox in the **Analysis** panel of the **Pack Options** or **Pile Options** tab is checked.

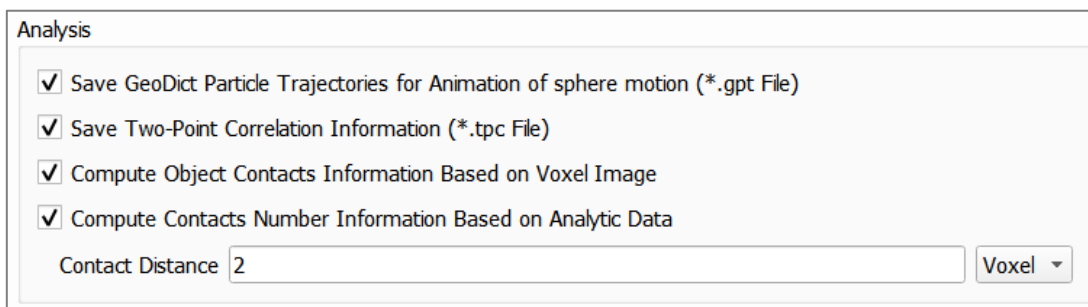

Information on the analytic and discretized (voxelized) sphere contacts is internally and automatically saved and appears in the Result Viewer of the result file (*.gdr) under the **Results – Report** and the **Results – Map** subtabs. This includes such information as the contact distance, mean coordination number, the number of contacts, and a list of all sphere contacts.

- ***.txt** are text files. **Convergence.txt** relates the convergence at a given time with a certain packing-density. **Restart.txt** contains information about the sphere distribution parameters to re-start the packing process. **Result.txt** contains the achieved packing density, which is set to zero for the piling process.
- ***.tpc** (two-point correlation) file contains a list with the distance between all spheres. *Optionally saved.*
- ***.log** files contain the chronological record of the packing process.
- ***.pde** are parameter files that contain the input data for the external packing code.
- ***.gsd** (GeoDict sphere distribution) files contain the diameter, probability and number of each distinct sphere type.
- **trajectories.gpt** (GeoDict particle trajectory) files contain a record of the movement of the spheres during the packing (or piling). This file can be used to visualize the packing process. *Optionally saved.*

- **particles.gpp** (GeoDict particle position) files contain information on the position of the spheres after the packing (or piling). *Optionally saved.*
- ***.gad** (GeoDict analytic data) files contain the analytic data about the geometry of the object packing, such as object Material ID, object type, object position, and (sphere) diameter.
- ***.gdt** file containing the **GeoDict** 3D voxelized geometry of the object packing.

Most of these output files can be opened in a text editor, such as Notepad++, for post-processing of statistical information.

SPHERE DISTRIBUTION

With **Count Probability** as the **Probability Mode**, the **Probability** value in the table refers to the number of spheres of a type. With **Volume Probability**, it refers to the volume of spheres of a type.

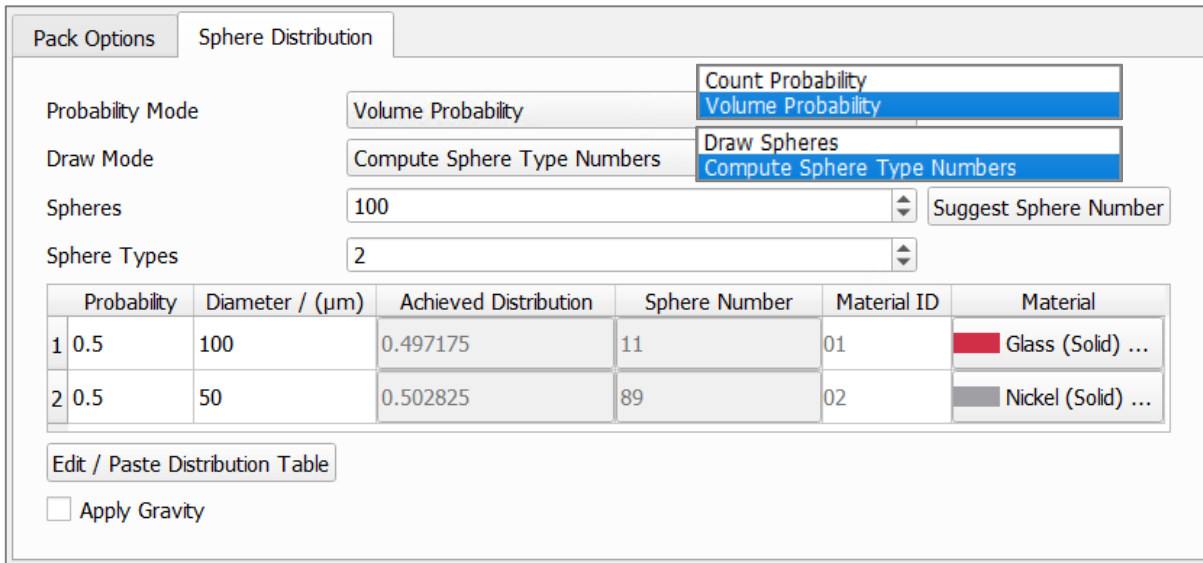

Draw Mode controls how the number of each sphere type is determined:

- **Draw Spheres:** A random generator sets the type of each sphere in the structure depending on the given probabilities. Thus, the number of spheres of each type depends on the Random Seed.
- **Compute Sphere Type Numbers:** The number of spheres for each type is computed analytically, based on the probabilities, but without a random generator. The number of spheres of each type is the same for different Random Seeds.

For example, choosing **Count Probability** and **Compute Sphere Type Numbers** and specifying that of 100 spheres, 70% should be 1 mm and 30% should be 0.5 mm, exactly 70 spheres have a diameter of 1 mm and 30 spheres have a diameter of 0.5 mm.

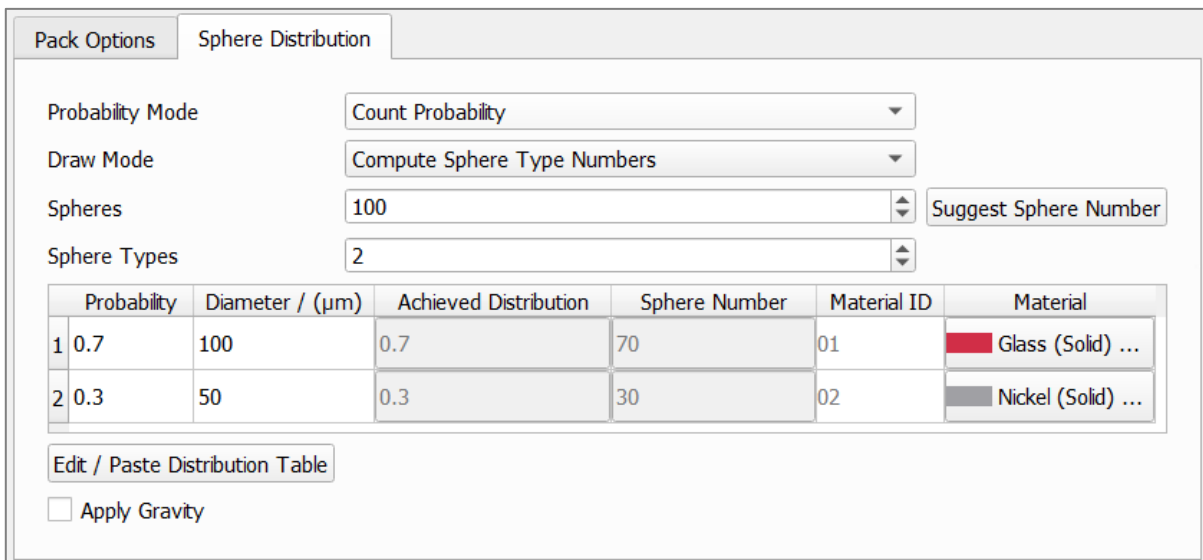

In contrast, selecting **Draw Spheres** determines that for each of the 100 spheres in the example the type is randomly drawn. Thus, each sphere has a 70% probability to have a diameter of 100 μm , and a 30% probability to have a diameter of 50 μm . Therefore, the **Achieved Distribution** of type 1 is dependent on the **Random Number**, and binomially distributed around an expectation value of 0.7.

	Probability	Diameter / (μm)	Achieved Distribution	Sphere Number	Material ID	Material
1	0.7	100	0.71	71	01	Glass (Solid) ...
2	0.3	50	0.29	29	02	Nickel (Solid) ...

Spheres refers to the number of spheres to be packed.

Sphere Types determines the number of different sphere types to be packed.

The distribution table contains the parameters for the different sphere types to be packed. The **Diameter** of each sphere type in the chosen units, and their **Probability**, as well as their **Material** can be directly entered. The parameters for up to 100 **Sphere Types** can be entered in the table.

Given the previously entered number of **Spheres**, and the values for **Diameter** and **Probability** for the distinct sphere types, **GrainGeo** draws the number of spheres for each type (**Sphere Number**). Under the **Achieved Distribution** tab, the reached ratio for each type is shown.

When working with **Volume probability** and strongly differing sphere diameters, it might happen that only a very small number of the larger spheres appears in the structure, or that they are completely missing.

By clicking **Suggest Sphere Number** a number of spheres is proposed so that ratios close to the desired probabilities can be reached. Depending on the chosen parameters (as above, e.g. **Volume Probability** and strongly differing **Diameters**), the suggested number of spheres might be large.

Click the **Edit / Paste Distribution Table** button to edit the values for **Diameter** and **Probability** (depending on the choice for probability mode, either **Count Probability** or **Volume Probability**) in the **Edit Sphere Distribution** dialog.

Clicking **Normalize** ensures that the **Probability** values sum up to one.

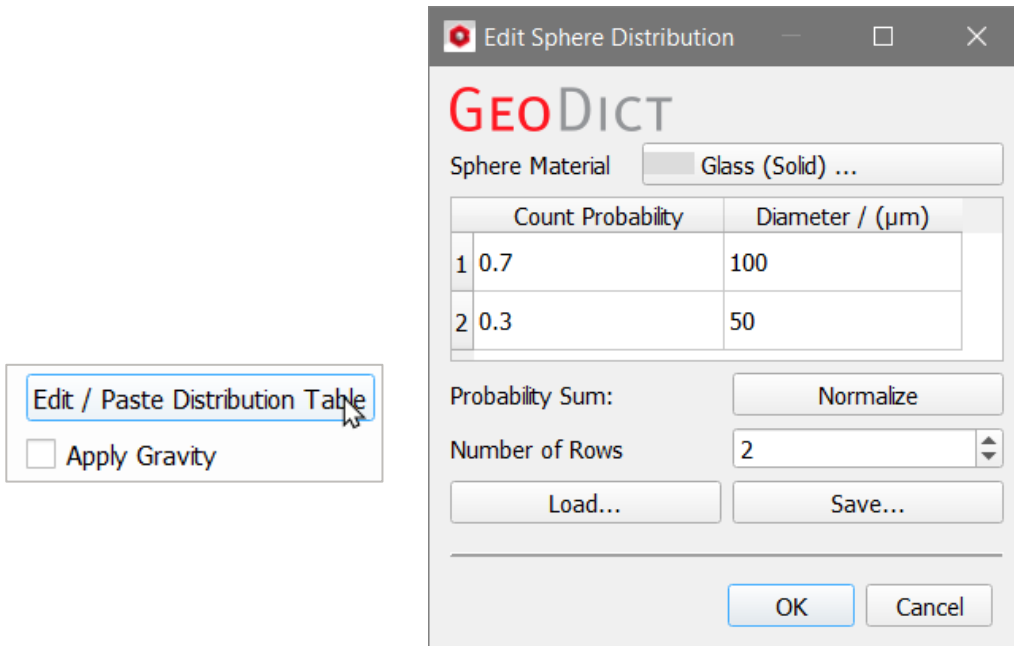

Alternatively, the distribution can be pasted from other software, for example from Microsoft Excel™, or it can be loaded from a *.txt-file. With the **Save...** button, the distribution table can be written to a file.

Checking **Apply Gravity** includes a simulation of gravitational force on the packed spheres after the packing process, so that the spheres “fall down” in the Z-direction from their positions in the packing. The effect of applying gravity to a packed structure is obvious for low packing density (under 30%). As the domain is always periodic for the packing, the spheres cutting the bottom of the domain reappear in the top. If this is not desired, use **ProcessGeo Crop** to crop the top of the domain.

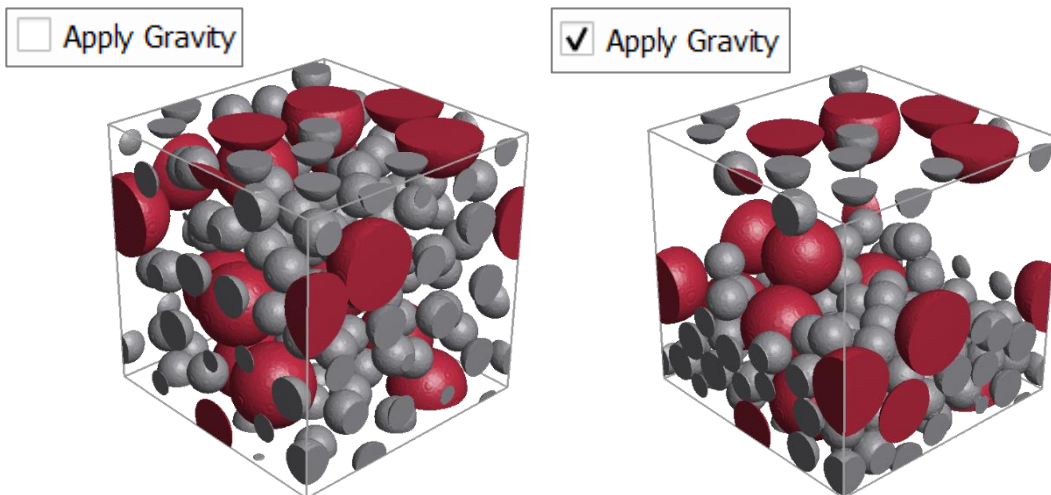

RE-COMPACT EXISTING PACKING

Re-Compact Existing Packing is useful when trying to achieve a higher packing density from an already existing packing result.

When choosing this option, the **Materials** panel is missing but some **Packing** (**Maximal Iterations**, **Maximal Run time**, **Packing Density**) and **Domain** parameters under the **Pack Options** tab can be set.

Pack Options Sphere Distribution

Packing Mode: SpherePack.gdr | Re-Compact Existing Packing | Browse

Packing

Random Seed: 347 | Maximal Iterations: 1000000

Packing Density: 0.63 | Maximal Run Time / (h): 24

Domain

NX: 300 | NY: 300 | NZ: 300

Analysis

Save GeoDict Particle Trajectories for Animation of sphere motion (*.gpt File)

Save Two-Point Correlation Information (*.tpc File)

Compute Object Contacts Information Based on Voxel Image

Compute Contacts Number Information Based on Analytic Data

Contact Distance: 2 | Voxel

Under the **Sphere Distribution** tab, all parameters are directly entered from the selected GDR file and from the corresponding result directory of a previous **GrainGeo** run. Additionally, the user can choose to **Apply Gravity**.

Pack Options Sphere Distribution

Probability Mode: Volume Probability

Draw Mode: Compute Sphere Type Numbers

Spheres: 100 | Suggest Sphere Number

Sphere Types: 2

	Diameter / (mm)	Probability	Achieved Distribution	Sphere Number	Material ID	
1	0.1	0.5	0.497175	11	01	M
2	0.05	0.5	0.502825	89	01	M

Edit / Paste Distribution Table

Apply Gravity

PILE ANALYTIC SPHERES

Many of the **Options** to pile analytic spheres are similar to the options shown above (pages 83ff.) to pack analytic spheres. For example, the options under the **Materials** and **Analysis** panels are identical.

As explained above for the packing process, a **Result File Name (*.gdr)** must be entered to save the results of every piling process. This **Result File Name** is applied to both the results file (*.gdr), and to the results folder (and the files in it) that are placed inside the chosen project folder.

The available **units** (m, mm, and μm) are selectable from the pull-down menu.

The parameters for the piling are organized in the **Pile Options** and **Sphere Distribution** tabs.

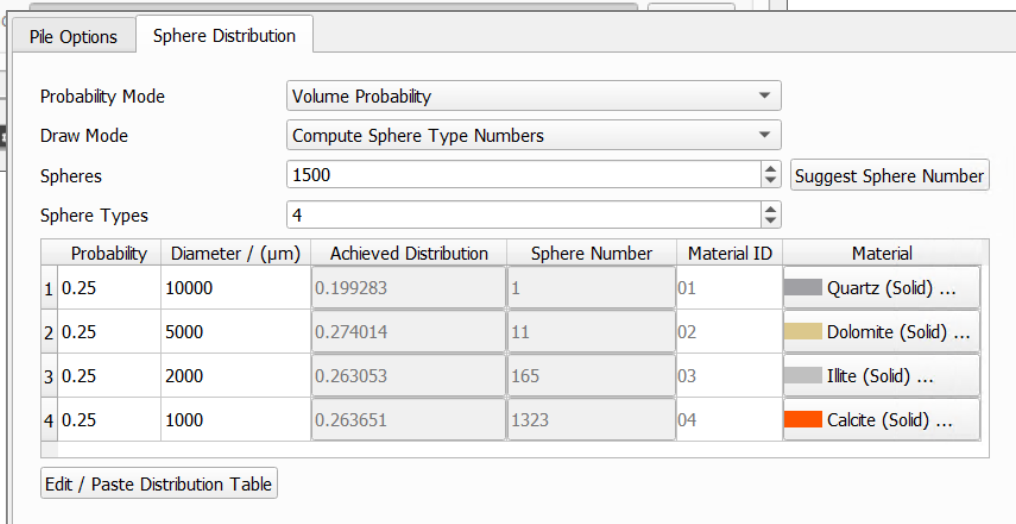
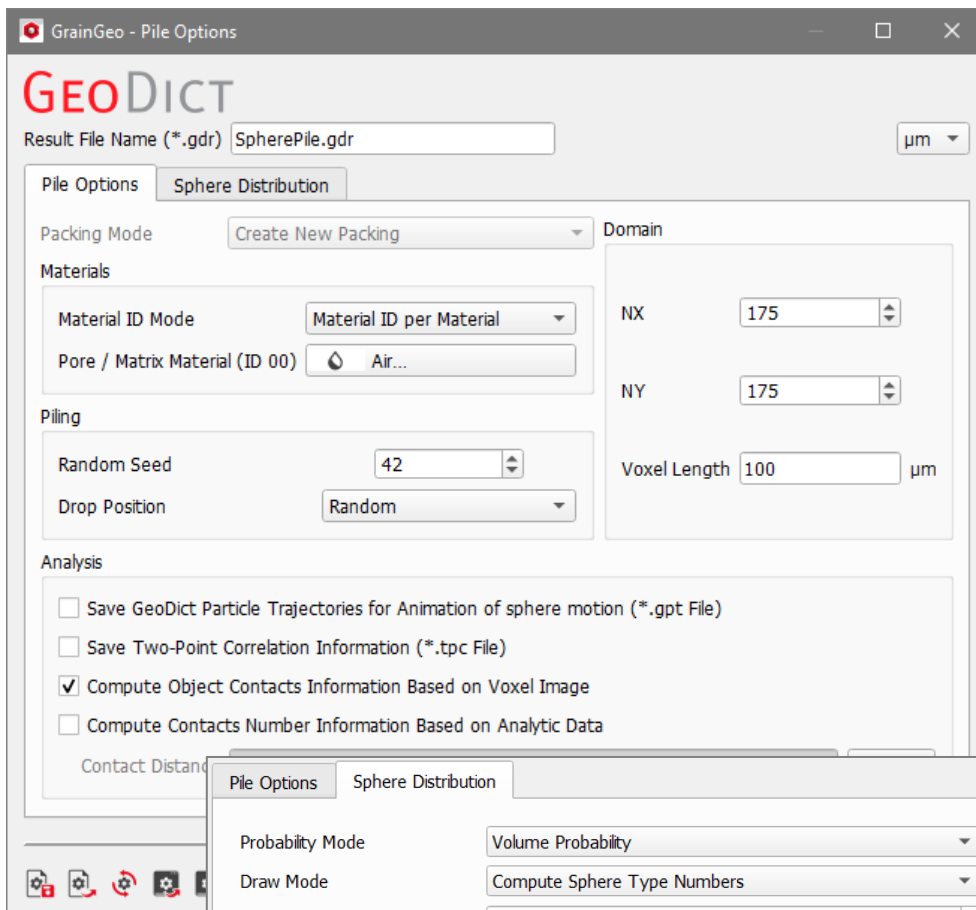
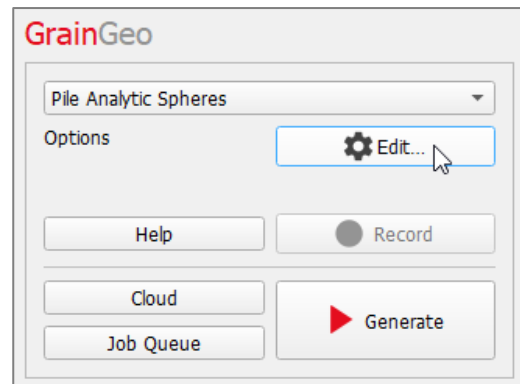

Domain

The **Domain** value for **NX** and **NY** can be chosen by direct insertion or by clicking the arrow buttons, to indicate the number (N) of voxels in **X** and **Y**-direction.

Since the spheres fall from the **Z**- direction, the size value for **Z** is determined by the height of the pile of spheres and depending on the number of spheres to be piled.

In the **Voxel Length** box, enter the length of the voxels in the selected units.

Piling

In the **Piling** panel, the **Drop Position** from **Center** or **Random** can be selected from the pull-down menu. When selecting **Center**, the spheres are dropped from the center of the X-Y plane, instead of being dropped from any random position on the plane.

The following piled structure is generated with the default options and a **Random Seed** of 362. Click **Generate** in the **GrainGeo** section to start the piling process.

STOCHASTIC FIELD THRESHOLDING

When choosing **Stochastic Field Thresholding** from the pull-down menu, structures can be created by generating and segmenting stochastic fields. Clicking the **Options' Edit...** button in the **GrainGeo** section opens the **Stochastic Field Thresholding** dialog.

At the top left of the **Stochastic Field Thresholding** dialog, the name for the file containing the generation results can be entered in the **Result File Name (*.gdr)** box. The default name can be kept, or a new name can be chosen, fitting the current project.

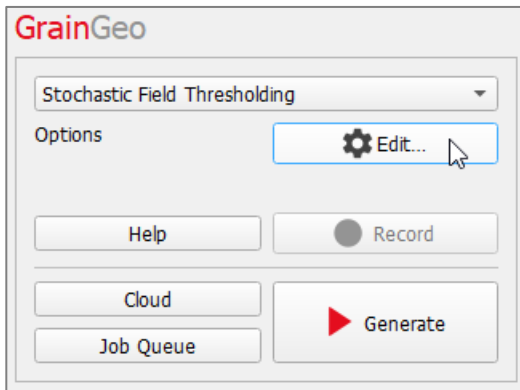

The available units (**m**, **mm**, **µm**, **nm** and **Voxel**) are selectable from the pull-down menu at the top right of the **Stochastic Field Thresholding** dialog. When the units are changed, the entered values are adjusted automatically.

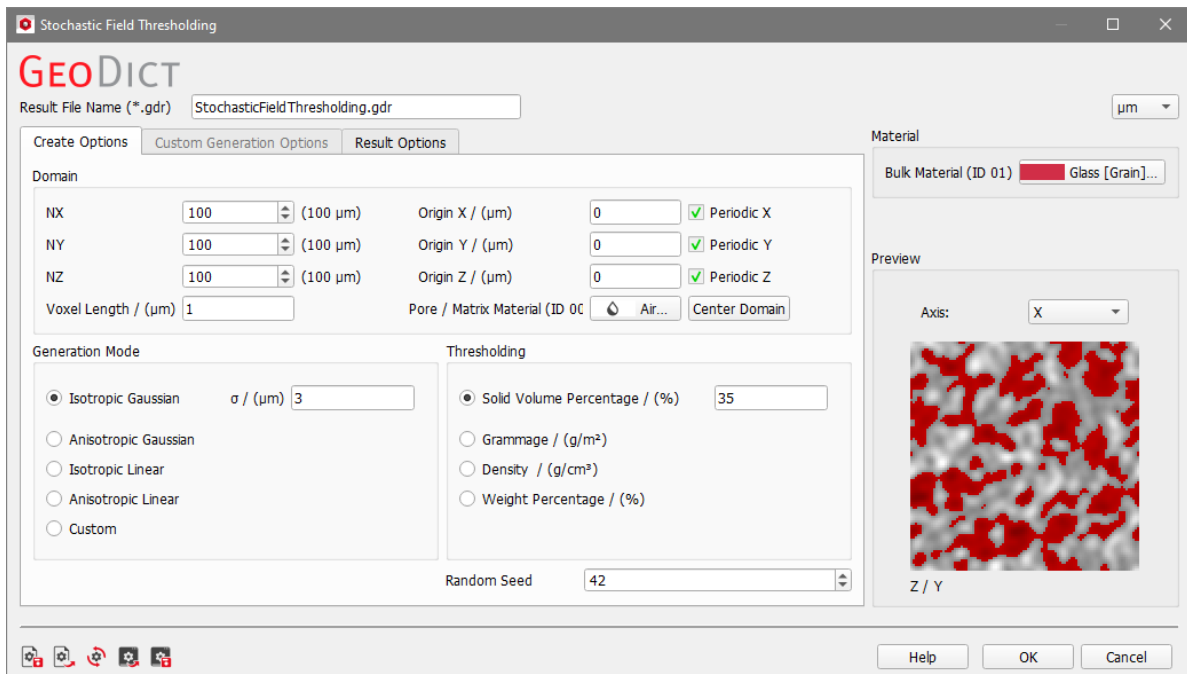

The **Stochastic Field Thresholding** dialog is organized using three tabs:

- **Create Options:** Determine general properties of the resulting structure, such as size, position, resolution, and solid volume percentage.
- **Custom Generation Options:** Choose individual combinations of stochastic fields to create a custom random field.

- **Result Options:** Determine if the random field should be saved in the result folder.

Additionally, the panels **Material** and **Preview** are available in the right column of the dialog.

MATERIAL

The generated structure consists of two materials. In the Material panel select the **Bulk Material (ID 01)** from the material data base.

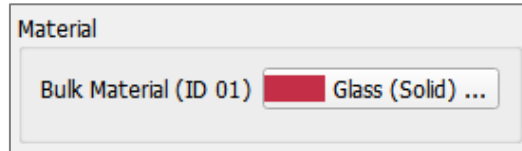

If **Grammage, Density** or **Weight Percentage** are selected for thresholding, also the **Temperature** can be edited. The temperature unit can be chosen as K, °C or °F. If Manual is chosen as material a **Bulk Density** must be entered.

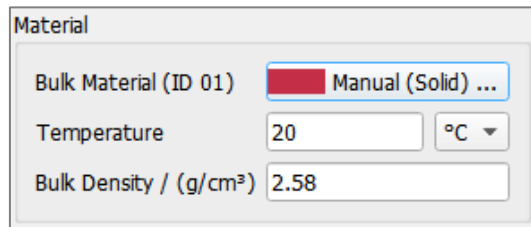

The **Pore / Matrix Material (ID 00)** is defined in the **Domain** panel. The material filling the pore space can be **Solid, Porous,** or **Fluid**. For a porous matrix material, a density can be entered, if grammage, density or weight percentage are chosen for thresholding.

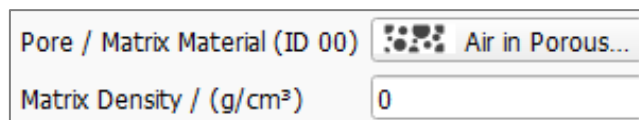

PREVIEW

In the bottom right of the **Stochastic Field Thresholding** dialog a preview of the generated random field (gray values) and the segmentation result (red for Material ID 01) is displayed.

The preview is automatically updated when changing the values for the **Domain, Generation Mode** and **Thresholding** parameters. The view direction can be selected from the pull-down menu for **Axis**.

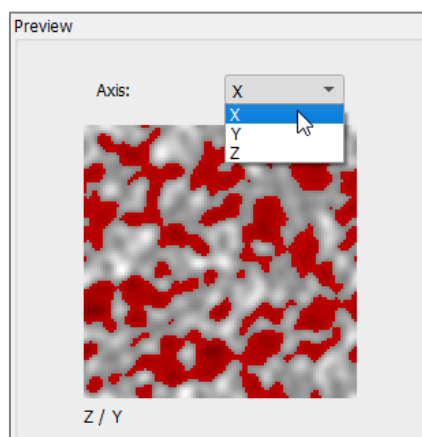

CREATE OPTIONS

The parameters defining the general properties of the granular structure are entered under the **Create Options** tab. They are grouped into the **Domain**, **Generation Mode** and **Thresholding** panels.

DOMAIN

The **Domain** panel contains the parameters defining the structure size (**NX**, **NY**, and **NZ**) in combination with the resolution (**Voxel Length**), as well as the **Origin** parameters and **Center Domain**.

These options are the same as for the **GrainGeo Create Options** described on page 6.

In general, the structure is periodic. Only if the parameters define a domain smaller than the chosen correlation length(s), periodicity cannot be achieved. That is because a bigger structure is generated and cropped to the desired size. In that case, warning messages appear in the result viewer for the affected directions. The runtime and memory requirements increase, corresponding to the needed domain size.

GENERATION MODE

The options in the **Generation Mode** panel control the distribution used for the stochastic field which is segmented to obtain the final structure. It is possible to choose **Isotropic Gaussian**, **Anisotropic Gaussian**, **Isotropic Linear**, **Anisotropic Linear**, or a **Custom** random field.

Isotropic Gaussian

An **Isotropic Gaussian** random field is used to create the structure. Enter the **Correlation Length** σ to define the standard deviation of the used Gauss kernel. With higher values the features of the generated structure become larger.

Generation Mode

- Isotropic Gaussian $\sigma / (\mu\text{m})$ 3
- Anisotropic Gaussian
- Isotropic Linear
- Anisotropic Linear
- Custom

In the following example observe how the feature size changes for two different correlation lengths, while all other parameters are kept the same.

Isotropic Gaussian $\sigma / (\mu\text{m})$ 3

Isotropic Gaussian $\sigma / (\mu\text{m})$ 10

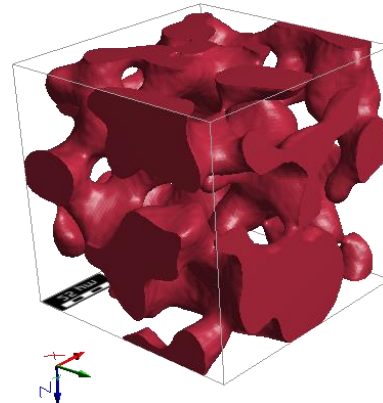
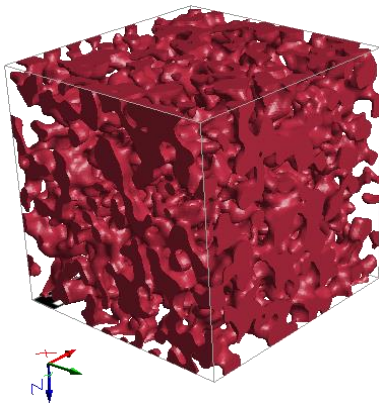

Anisotropic Gaussian

An **Anisotropic Gaussian** random field is used to create the structure. Enter the **Correlation Length** for X-direction σ_X , Y-direction σ_Y and Z-direction σ_Z . These values define the standard deviations in each main axis of the used Gauss kernel. Higher values lead to larger pores. If the same value is entered for all three directions, it is the same as Isotropic Gaussian.

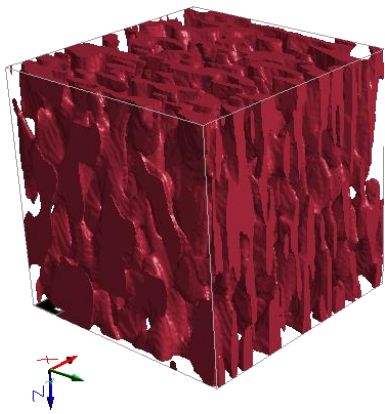

Generation Mode

Isotropic Gaussian

Anisotropic Gaussian

σ_X / (μm) σ_Y / (μm) σ_Z / (μm)

Isotropic Linear

Anisotropic Linear

Custom

In the following example, the values 3, 10 and 20 are used for σ_X , σ_Y and σ_Z respectively. Observe the different feature shapes for the different view directions.

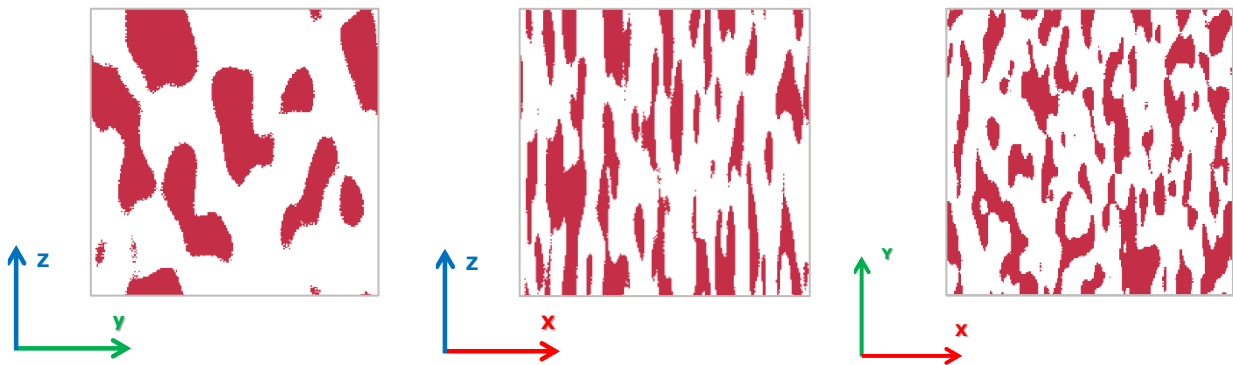

Isotropic Linear

If **Isotropic Linear** is selected, a linear decreasing correlation function is used to create the stochastic field. It starts in 0 with the value 1. The correlation function reaches 0 in σ and stays 0 for larger values. Thus, the gradient is $-1/\sigma$ between 0 and sigma and 0 for larger values.

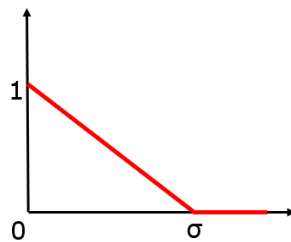

With higher values the features of the generated structure become larger. It can be necessary to postprocess the results with ProcessGeo **Cleanse**.

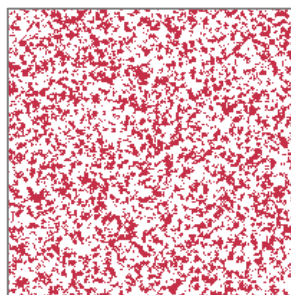
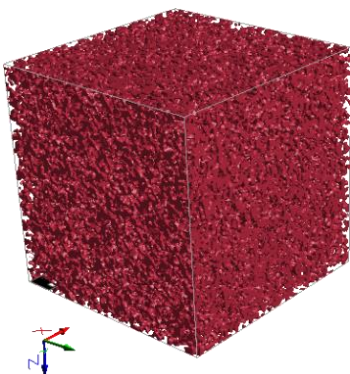

Generation Mode

Isotropic Gaussian

Anisotropic Gaussian

Isotropic Linear σ / (μm)

Anisotropic Linear

Custom

Anisotropic Linear

If **Anisotropic Linear** is selected, different linear decreasing correlation functions are used for X-, Y- and Z-direction to create the stochastic field. They are defined as described for the isotropic case above. Enter σ_X , σ_Y and σ_Z to determine the corresponding gradients: $-1/\sigma_X$, $-1/\sigma_Y$ and $-1/\sigma_Z$. Higher values lead to larger features. It can be necessary to postprocess the results with **ProcessGeo Cleanse**.

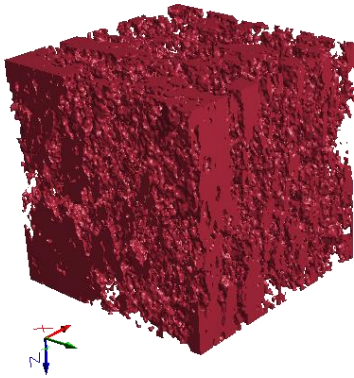

Generation Mode

Isotropic Gaussian

Anisotropic Gaussian

Isotropic Linear

Anisotropic Linear

σ_X / (μm) σ_Y / (μm) σ_Z / (μm)

Custom

In this example, observe the differences in the three view directions.

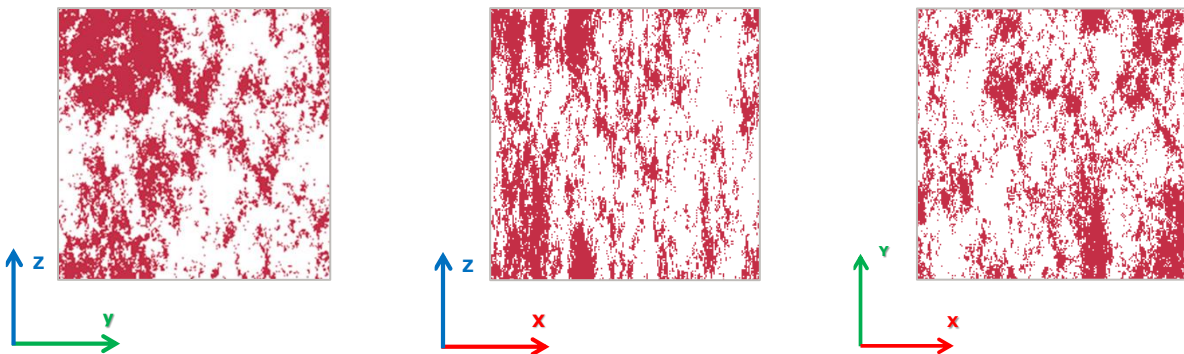

Custom

A **Custom** stochastic field is created and segmented to generate the structure.

If checked the tab **Custom Generation Options** becomes available. Combine the different random field and gradient options in the **Custom Generation Options** tab. This tab can also be reached by clicking **Go To Tab** in the **Generation Mode** panel. In addition to linear and Gaussian random fields also linear gradient, sphere gradient and membrane gradient are available. These options are described in detail on page [103 ff.](#)

Generation Mode

Isotropic Gaussian

Anisotropic Gaussian

Isotropic Linear

Anisotropic Linear

Custom

THRESHOLDING

The parameters in the **Thresholding** panel of the **Stochastic Field Thresholding** dialog define the criteria for the segmentation threshold applied to the generated stochastic field to obtain the structure. The available parameters are **Solid Volume Percentage (%)**, **Grammage (g/m²)**, **Density (g/cm³)** or **Weight Percentage (%)**.

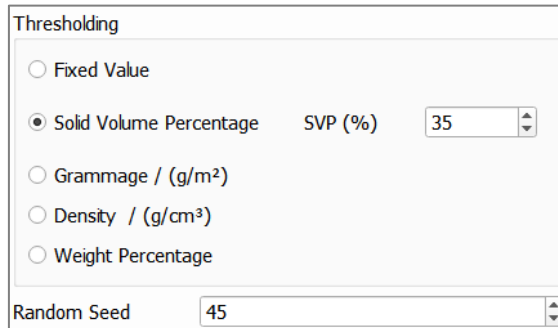

When **Grammage**, **Density** or **Weight Percentage** are chosen as stopping criterion, the temperature must be set as additional parameter in the **Material** panel. The density of the constituent materials will be set with respect to the chosen temperature based on the **Material Database**.

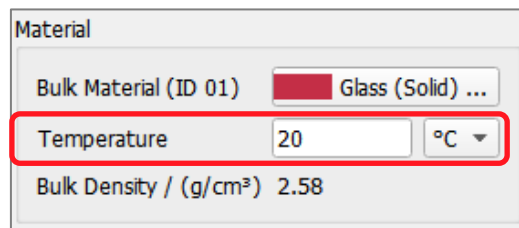

When choosing **Solid Volume Percentage**, the **Temperature** parameter is not available.

Solid Volume Percentage

Solid Volume Percentage (SVP) determines the fraction of the total volume in percent that the structure should have. Accepted values range from 0 to 100%.

For example, a structure with a **Solid Volume Percentage** of 40 consists of 40% solid and 60% void space. Porosity is defined as $(1 - SVP/100)$. The threshold to segment the stochastic field is chosen to match the given SVP. Observe the difference in a structure when varying the solid volume percentage from 5%, to 20% and finally to 40%, while all other parameters are left unchanged.

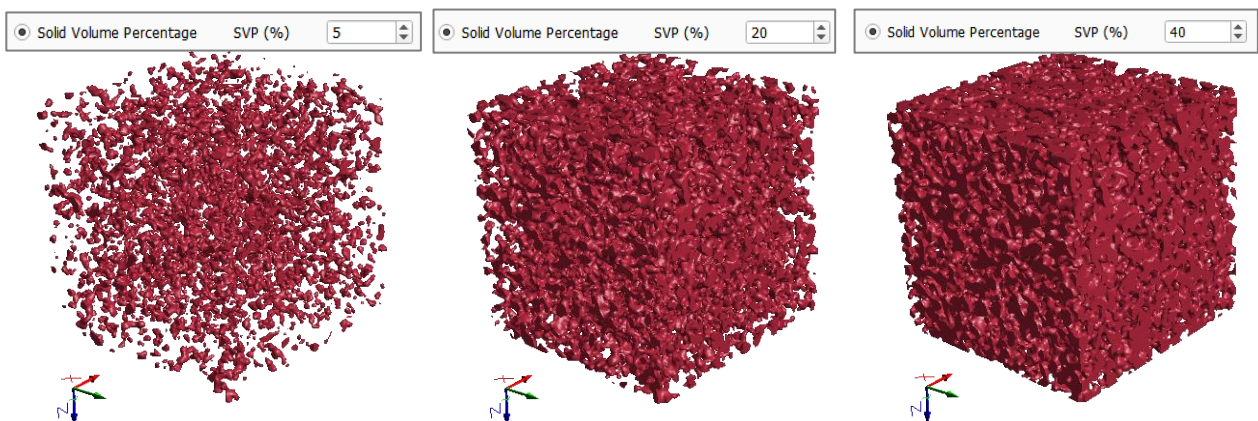

Grammage

The **Grammage** (g/m^2) determines the mass per unit area (in the XY-Plane) of the resulting structure. When **Grammage** is chosen as stopping criterion, the **Density** (g/cm^3) of the **Bulk Material** must be defined in the **Material** panel and the temperature must be set.

Density

The **Density** (g/cm^3) of the resulting structure depends on the density of the chosen materials, see page [97](#). It cannot be set smaller than the lowest occurring density or larger than the highest occurring density.

Object Weight Percentage

The **Object Weight Percentage** determines the weight of the created object in relation to the weight of the whole structure (including the pore material). Choosing this option only makes sense when the density of the **Pore / Matrix Material** is greater than zero. Otherwise, the domain will stay empty. See page [24](#) for more information.

RANDOM SEED

Random Seed initializes the random number generator behind the stochastic field generator. Changing its value produces different sequences of random numbers and hence, different realizations of the specified structure. If all settings are equal, generating with the same **Random Seed** value produces an identical structure. **Random Seed** must be a non-negative integer number.

CUSTOM GENERATION OPTIONS

The stochastic field and gradient types available for the generation are organized and listed in panels. For all objects, the left column of the panel contains the **Component Type** name, the **Relative Influence** and the **Absolute Influence**. The absolute influence is computed automatically from the corresponding relative influence.

The resulting combined random field is the weighted sum of all components, where the weights depend on the **Relative Influence**.

The middle column shows a preview of the defined field or gradient. In the right column, the stochastic parameters of the components can be entered. These parameters include correlation length, direction vector and perpendicular axis.

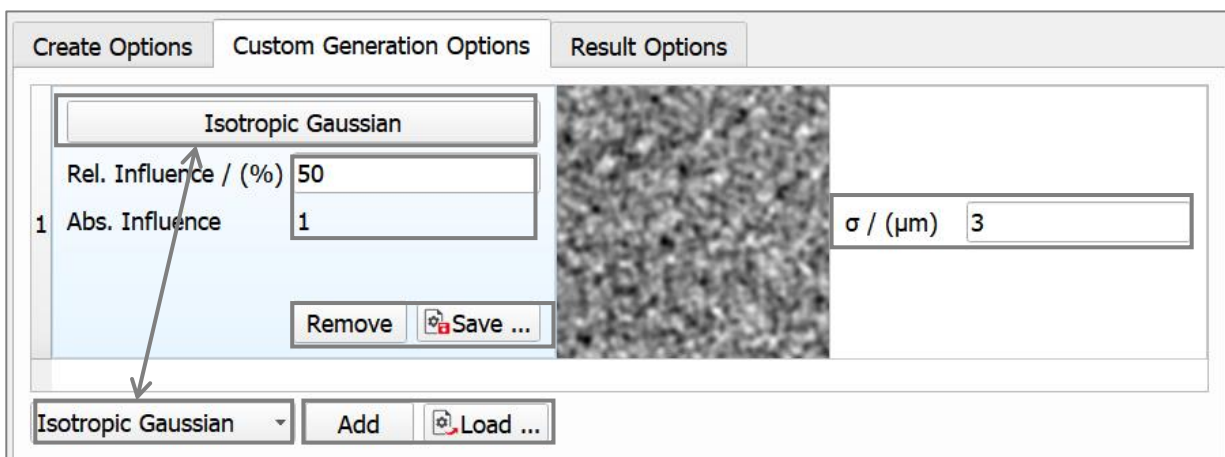

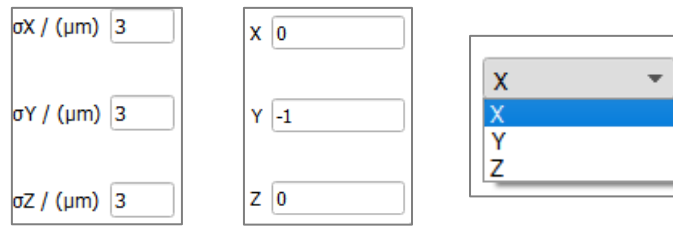

Isotropic Gaussian is the default **Component**. At the bottom left of the dialog, clicking **Add** inserts other components chosen from the component pull-down menu. Previously saved components with individually defined parameters can be loaded via the **Load...** button.

Components can be discarded again when clicking **Remove** in the left panel or can be saved as predefined component using the **Save...** button.

COMPONENTS

The **Random Field and Gradient Components** are selected from the pull-down menu or can be loaded via the **Load...** button at the lower left of the **Custom Generation Options** tab.

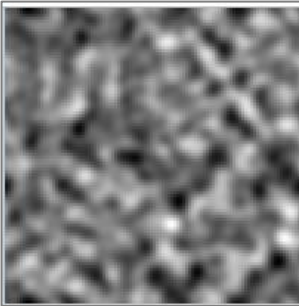
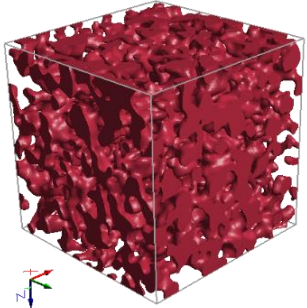
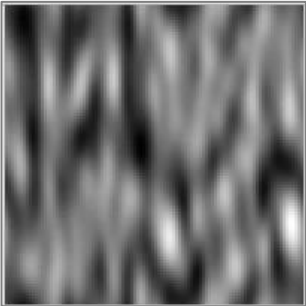
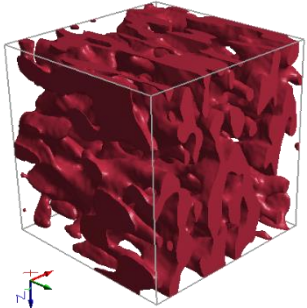
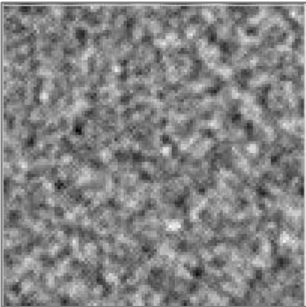
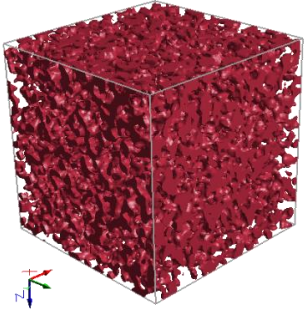

The following table summarizes the components that can be used with **GrainGeo Stochastic Field Thresholding** commands: **Isotropic Gaussian**, **Anisotropic Gaussian**, **Isotropic Linear**, **Anisotropic Linear**, **Linear Gradient**, **Sphere Gradient** and **Membrane Gradient**.

Stochastic field	Field type	Example
	Isotropic Gaussian	
	Anisotropic Gaussian	
	Isotropic Linear	

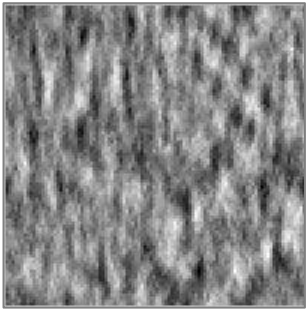
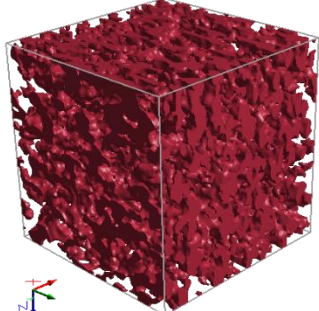
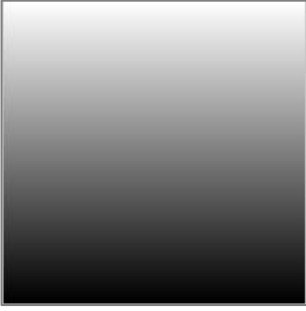
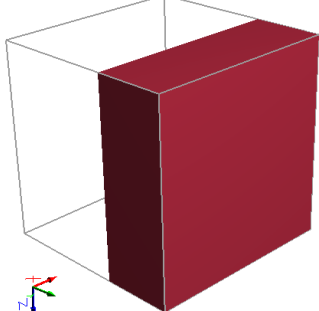
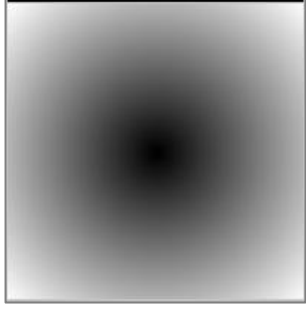
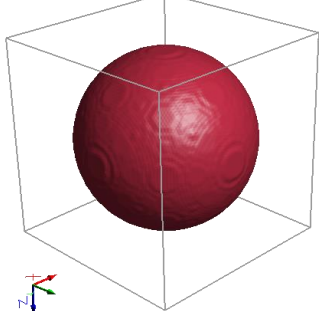
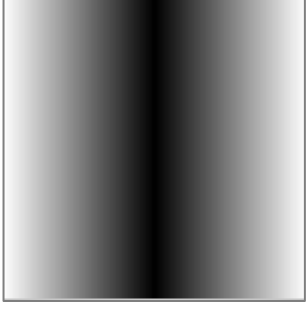
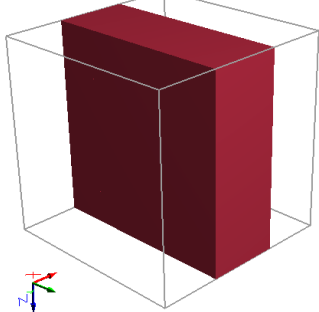
	<p>Anisotropic Linear</p>	
	<p>Linear Gradient</p>	
	<p>Sphere Gradient</p>	
	<p>Membrane Gradient</p>	

COMPONENT PARAMETERS

For **Isotropic Gaussian**, **Anisotropic Gaussian**, **Isotropic Linear**, and **Anisotropic Linear**, the parameters in the right column are the same as described for Generation Mode on page [99](#).

σ / (μm)

σ_X / (μm)

σ_Y / (μm)

σ_Z / (μm)

For **Linear Gradient**, enter the desired direction vector of the gradient.

For the default (0,-1,0) the field starts with black in the bottom and smoothly becomes lighter in Y-direction.

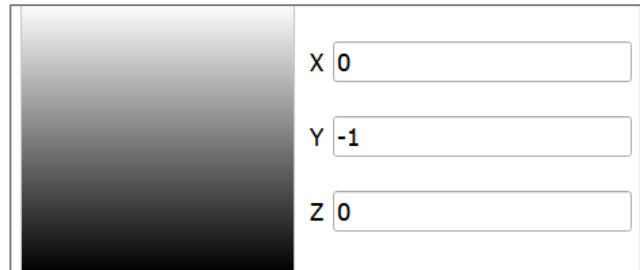

No parameters can be entered for **Sphere Gradient**.

The gradient always starts black in the center of the domain and becomes smoothly lighter towards the borders, resulting in a sphere after thresholding, if no other components are selected.

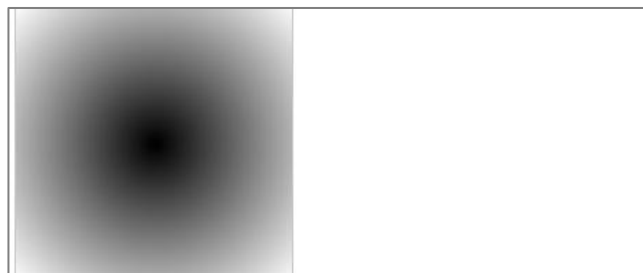

For **Membrane Gradient**, select the axis perpendicular to the membrane from the pull-down menu. If, for example, X is chosen, the gradient starts as a black plane perpendicular to the X-axis in the center of the structure.

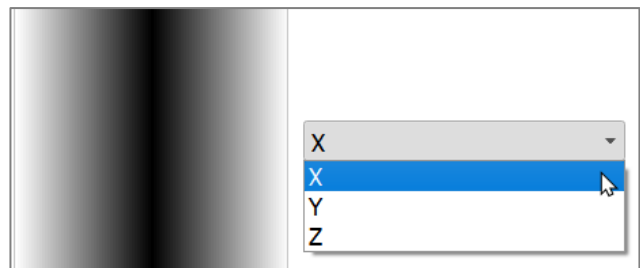

Depending on the entered parameters, it might be necessary to change the preview direction in the **Preview** panel on the bottom right of the dialog to see a preview of the gradient in the middle column.

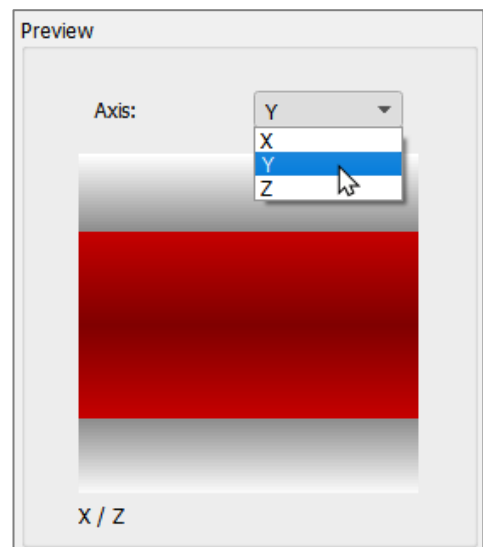

Using more than one component, the resulting combined random field is the weighted sum of all components, where the weights depend on the **Relative Influence**.

In this example, a combination of **Isotropic Gaussian** and **Linear Gradient** was selected. With **Rel. Influence** of 100 for the **Isotropic Gaussian** field and 1 for the **Linear Gradient**, observe, how the density of the structure differs according to the entered gradient vector (0,1,1).

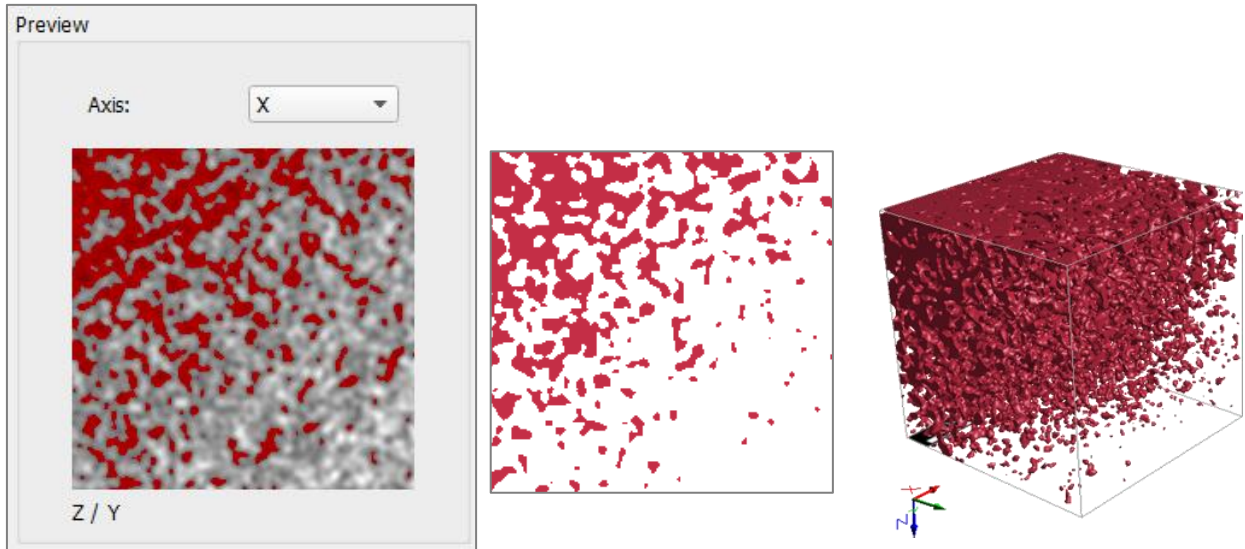

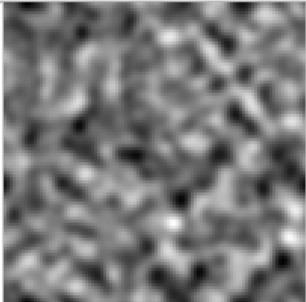
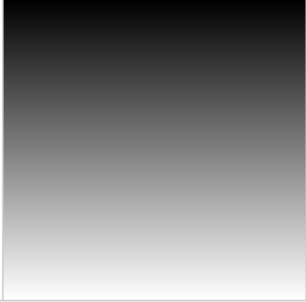
Isotropic Gaussian			σ / (μm) <input type="text" value="3"/>	
Rel. Influence / (%)	<input type="text" value="100"/>			
1 Abs. Influence	0.990099			
<input type="button" value="Remove"/> <input type="button" value="Save ..."/>				
Linear Gradient			X <input type="text" value="0"/>	
Rel. Influence / (%)	<input type="text" value="1"/>			Y <input type="text" value="1"/>
2 Abs. Influence	0.00990099			Z <input type="text" value="1"/>
<input type="button" value="Remove"/> <input type="button" value="Save ..."/>				

In this example, a combination of **Isotropic Gaussian**, **Linear Gradient** and **Sphere Gradient** was selected. With rel. influence of 100 for the **Isotropic Gaussian** field, 8 for the **Linear Gradient** and 70 for the **Sphere Gradient**, the structure forms a hill with a rough surface.

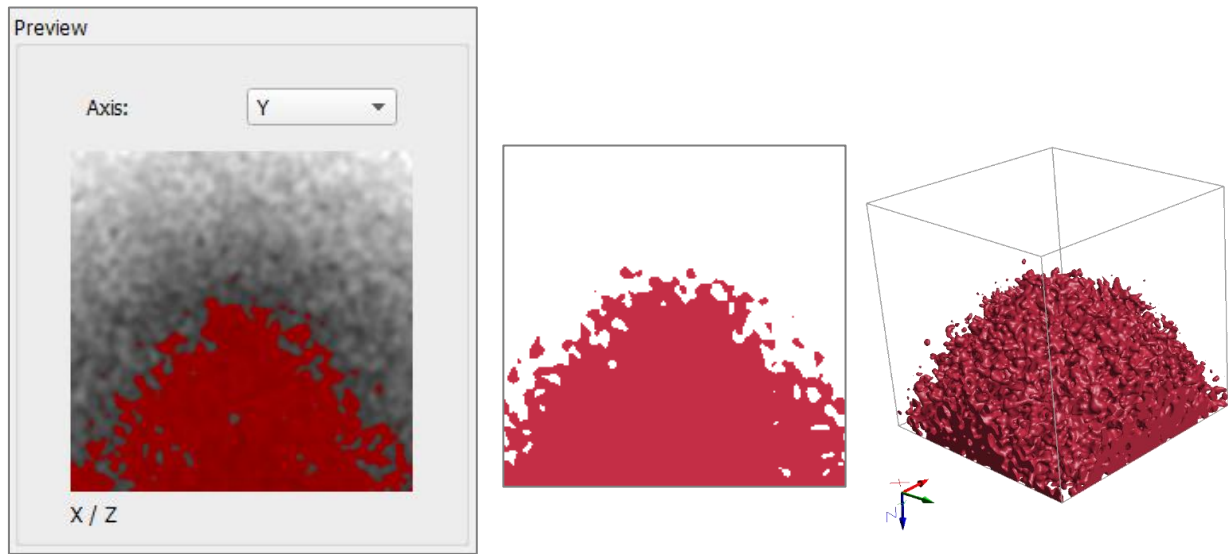

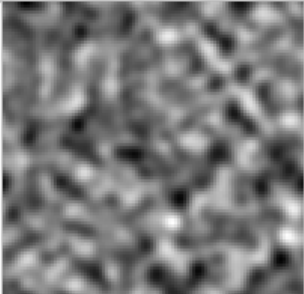
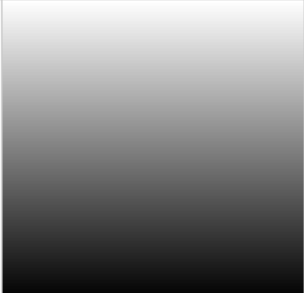
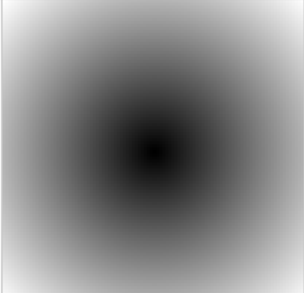
<div style="border: 1px solid gray; padding: 5px; text-align: center;">Isotropic Gaussian</div>			σ / (μm) <input type="text" value="3"/>
1	Rel. Influence / (%) <input type="text" value="100"/> Abs. Influence 0.561798 <input type="button" value="Remove"/> <input type="button" value="Save ..."/>		
<div style="border: 1px solid gray; padding: 5px; text-align: center;">Linear Gradient</div>			X <input type="text" value="0"/> Y <input type="text" value="0"/> Z <input type="text" value="-1"/>
2	Rel. Influence / (%) <input type="text" value="8"/> Abs. Influence 0.0449438 <input type="button" value="Remove"/> <input type="button" value="Save ..."/>		
<div style="border: 1px solid gray; padding: 5px; text-align: center;">Sphere Gradient</div>			
3	Rel. Influence / (%) <input type="text" value="70"/> Abs. Influence 0.393258 <input type="button" value="Remove"/> <input type="button" value="Save ..."/>		

RESULT OPTIONS

GrainGeo always saves the generated structure as a GeoDict structure file (*.gdt) (GeoDict binary data). The file is placed in an automatically created result folder inside the chosen project folder (**File** → **Choose Project Folder...** in the Menu bar).

The **Structure File** as well as the result folder, take the name entered as **Result File Name (*.gdr)** at the bottom of the dialog.

An additional option to save generation data, is to check **Save Random Field (*.gvf)** to also save the generated stochastic field in the result folder.

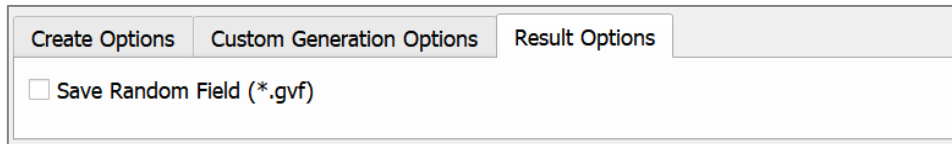

This random field can also be loaded from the result file in the **Result Viewer**. Move to the **Data Visualization** tab and click **Solid Volume Fraction (*.gvf)**.

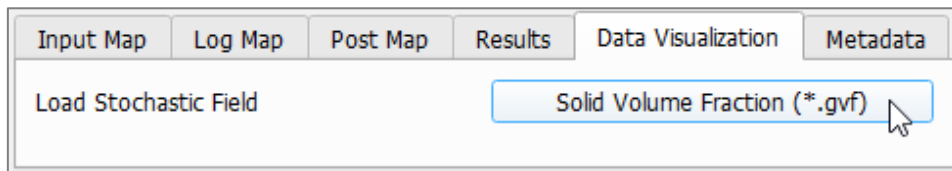

In the opening dialog click **OK**.

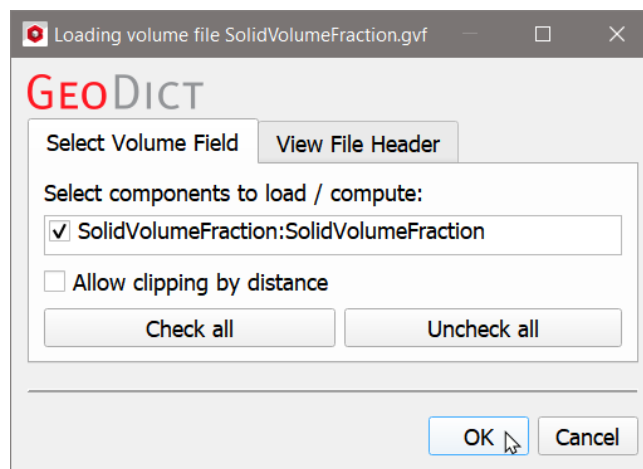

The visualization of the structure can be turned off by unchecking the **Structure** tab in the visualization panel above of the visualization area in the GeoDict GUI. To learn more about the GeoDict visualization settings, e.g. how to change the color of the volume field, see the [Visualization](#) handbook of this User Guide.

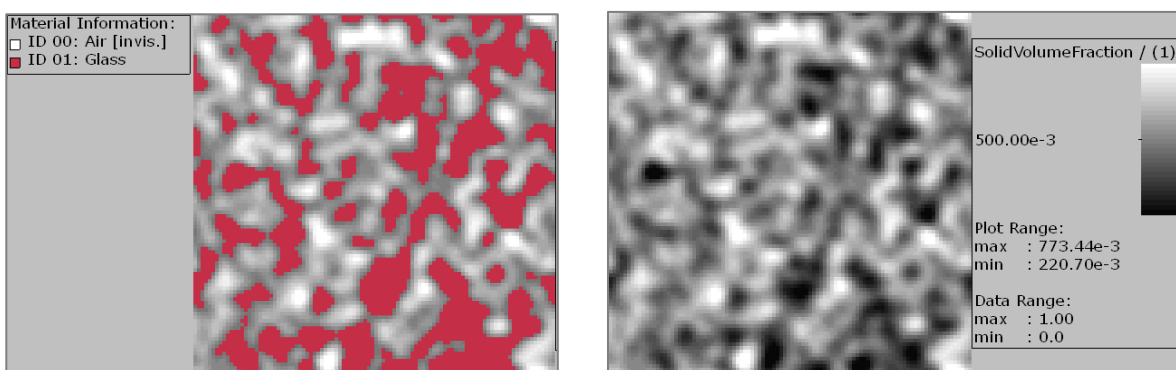

The parameters entered in the **Stochastic Field Thresholding** dialog can be saved into *.gps (GPS, GeoDict Project Settings) files and/or loaded from them. Remember to restore and reset your (or GeoDict's) default values through the icons at the bottom of the dialog when needed and/or before every GrainGeo run.

Resting the mouse pointer over an icon prompts a Tooltip showing the icon's function to appear.



DISTRIBUTE

When **Distribute** is selected from the pull-down menu in the **GrainGeo** section, the objects are uniformly spread throughout the structure. Only structures that contain analytic information (GAD format) can be used for the distribution of objects.

To use this feature, the domain must be periodic, and the objects are not allowed to overlap. **Distribute** allows to create a homogeneous structure, for example from piled structures created with **Pile Analytic Spheres**.

Clicking the **Options' Edit...** button opens the **Distribute Options** dialog:

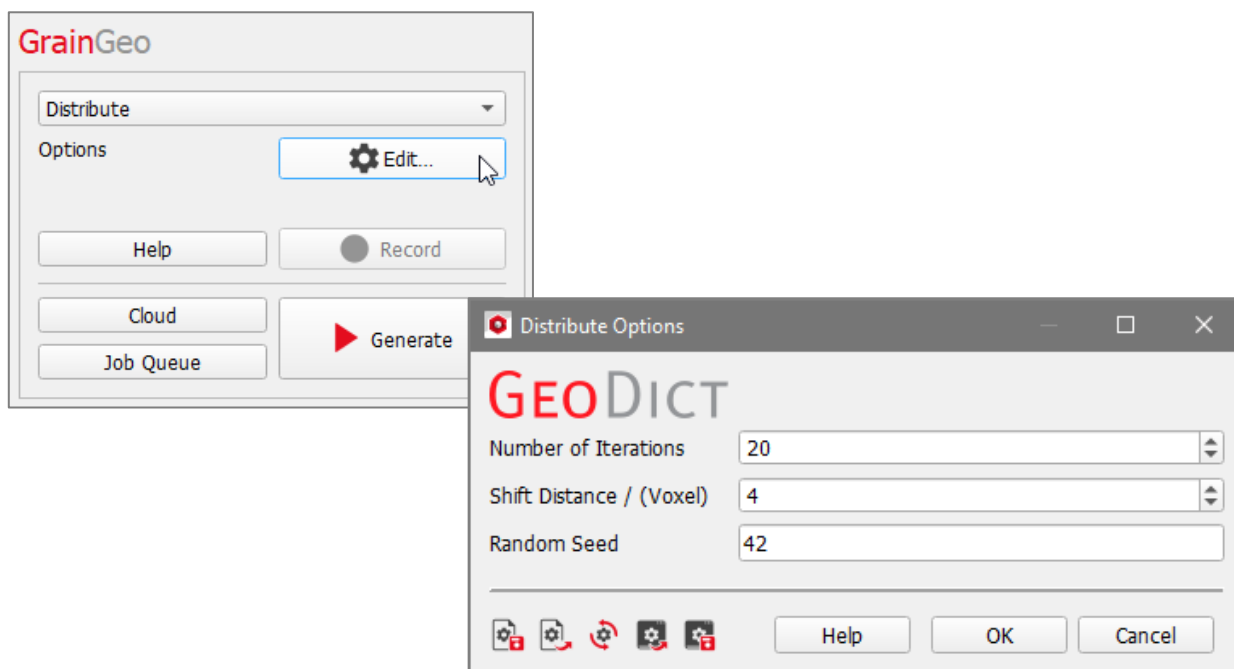

When the desired parameters have been entered in the **Distribute Options** dialog, clicking **OK** closes the dialog and returns to the **GrainGeo** section.

Clicking **Generate** starts the distribution process.

To save the result of the distribution process, select **File** → **Save Structure As...** in the Menu bar.

A grain structure containing GAD information must be in memory.

Without a structure in memory, clicking **Generate** results in an error message.

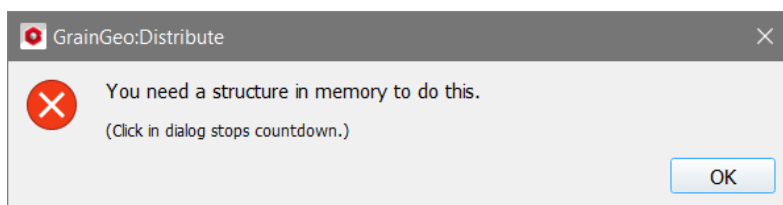

When the structure is not periodic, an information message appears indicating that periodicity will be applied in all three directions and the loaded structure will be treated as periodic. The GAD objects are still distributed.

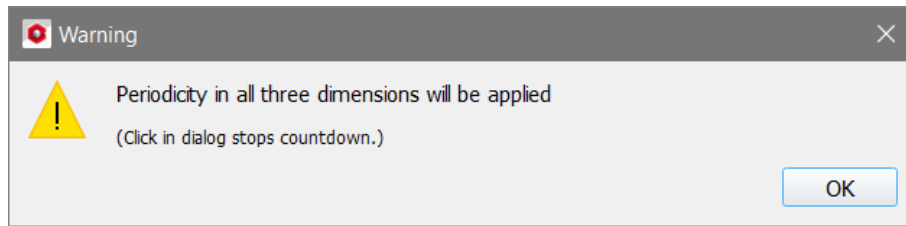

If the loaded structure contains overlap the distribution is not executed and an error message appears.

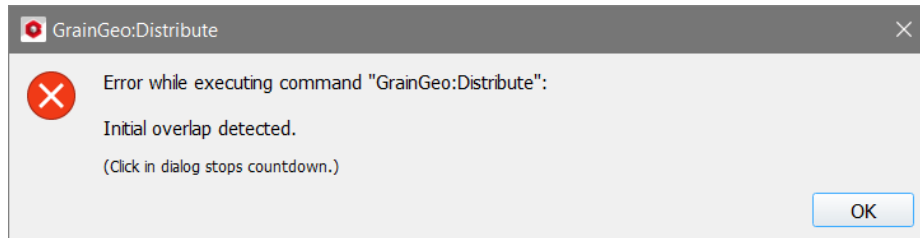

In the **Distribute Options** dialog, **Number of Iterations**, **Shift Distance**, and **Random Seed** specify the distribution process.

Observe the process of distributing the spheres in a 200 x 200 x 200 structure, periodic in all directions, generated with **GrainGeo - Create** with a Voxel Length of 1 μm , and imported as GAD file. The sphere centers follow a density distribution, which results in a layered structure.

The following values are used here for the distribution process: **Number of Iterations** is 40, **Shift Distance** is 6 voxels, **Random Seed** is 4.

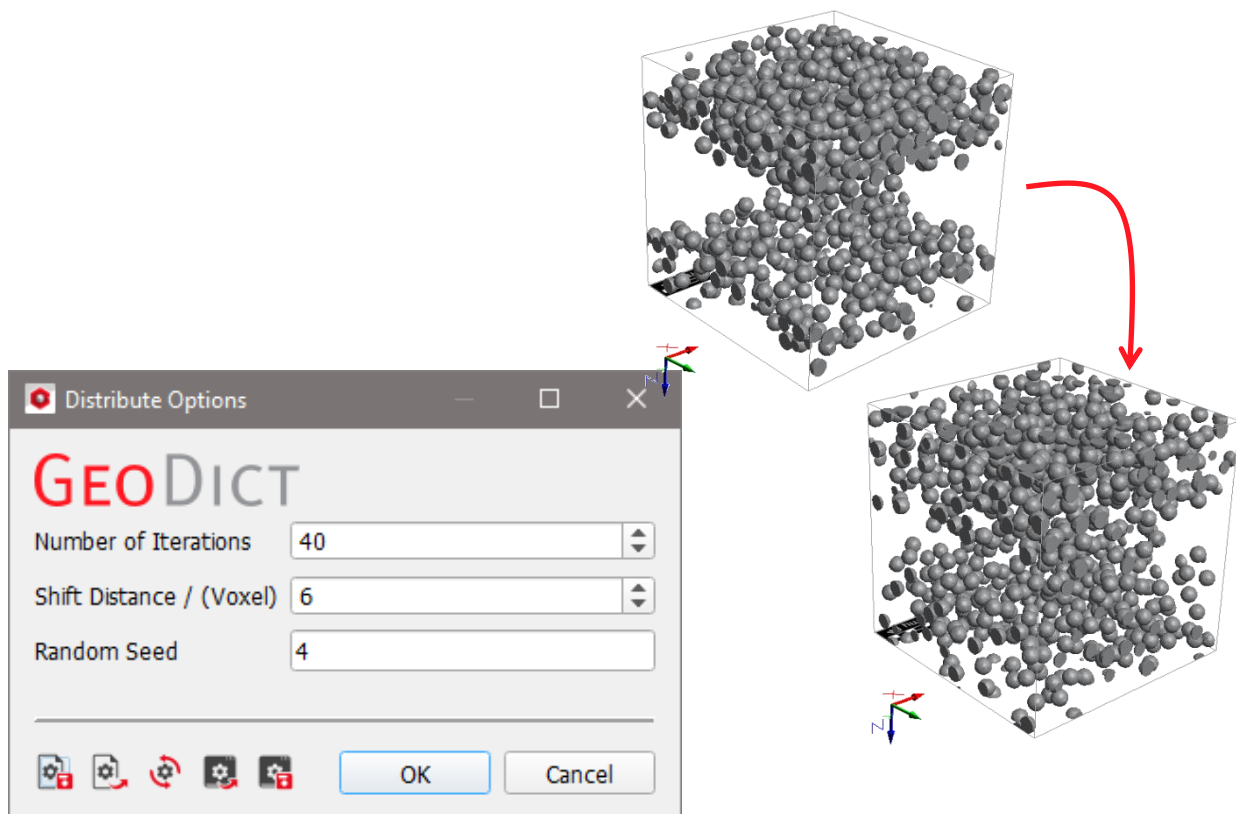

The **Number of Iterations** determines how many distribution steps are done. More distribution steps lead to a wider distribution of the objects, which is getting closer to a uniform distribution.

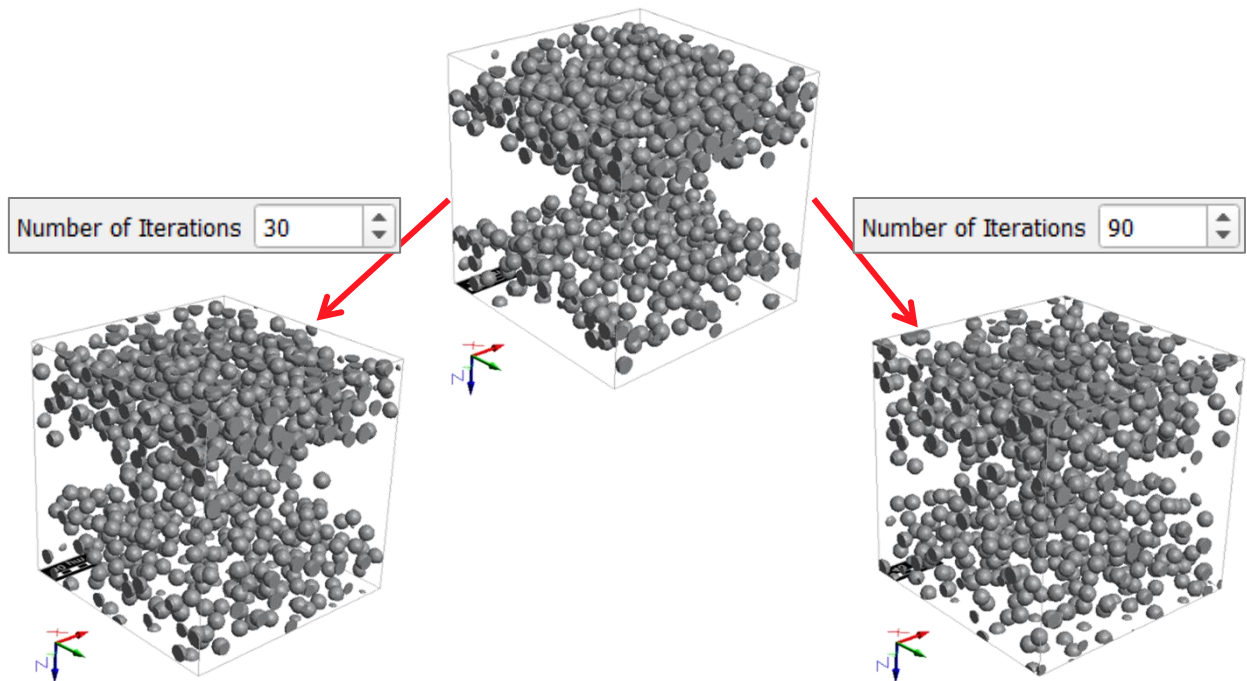

The **Shift Distance** determines the maximal object movement during a single iteration. Large shift distances lead to a longer computing time per iteration. Observe the effect of increasing the shift distance from 1 to 4 and then to 10, while the number of iterations is kept at 20.

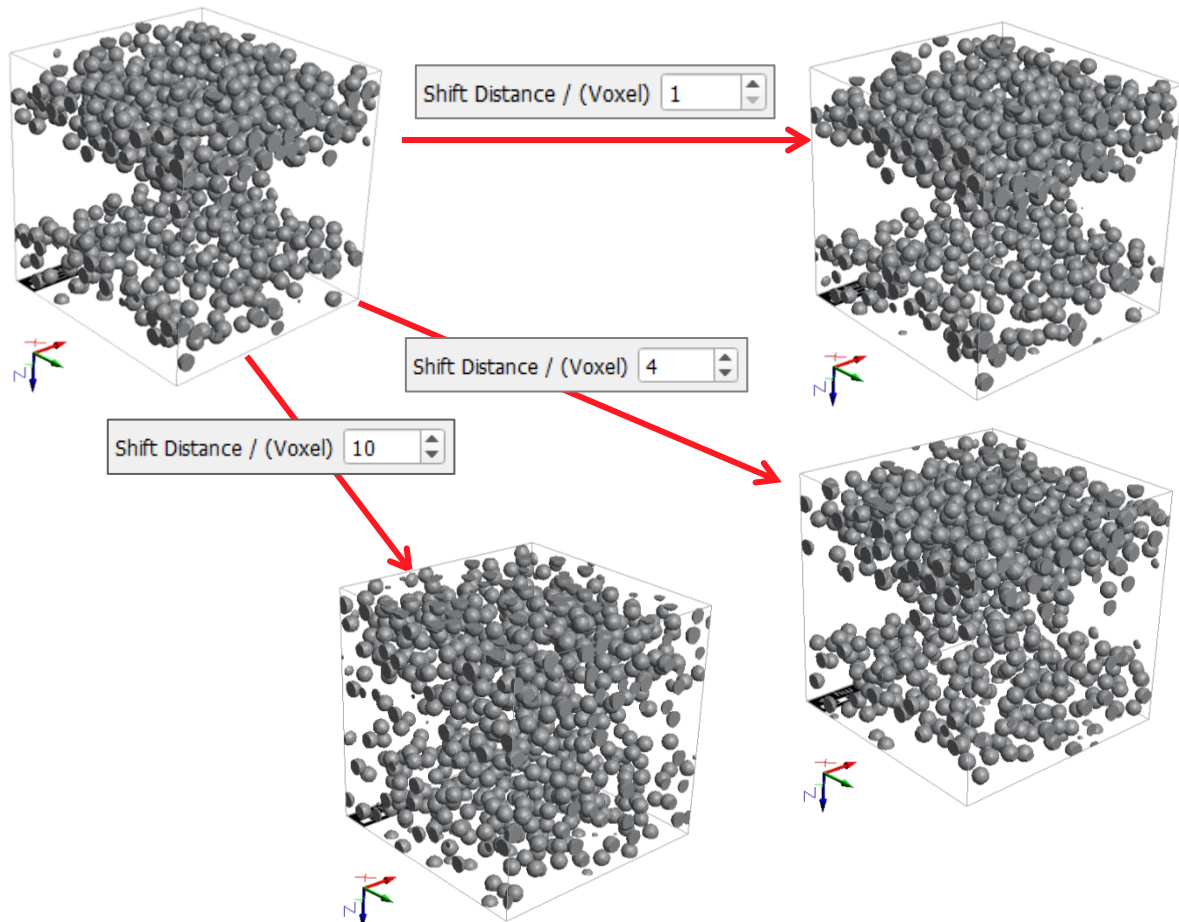

Random Seed is a simulation parameter controlling the sequence in which objects are distributed. Thus, different random seeds lead to slightly different distributed structures. The random seed increases automatically with every distribution process.

SINTER & CRYSTALLIZATION

With **Sinter & Crystallization**, virtually sintered and crystallized structures can be generated from **GeoDict** analytic structures (GAD format). The structure is virtually compressed until a desired parameter is reached (**Sinter Mode**). The voxel size in the structure decreases, while the number of voxels in the structure remains constant. Grains are deformed at their touching points and an **Interface Material** can be added.

Clicking the **Options' Edit...** button opens the **Sinter Options** dialog to enter the desired parameters. Clicking **OK** closes the dialog and returns to the **GrainGeo** section. Clicking **Generate** starts the sintering process.

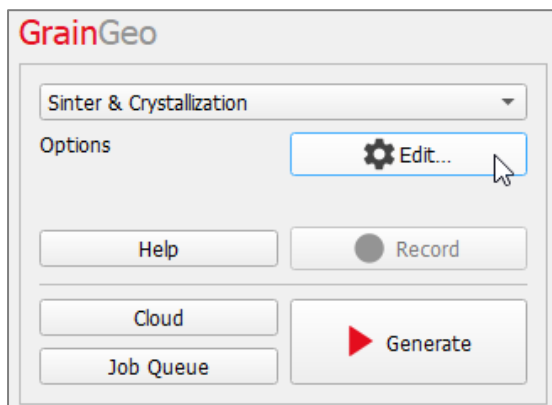

A structure containing GAD information must be in memory.

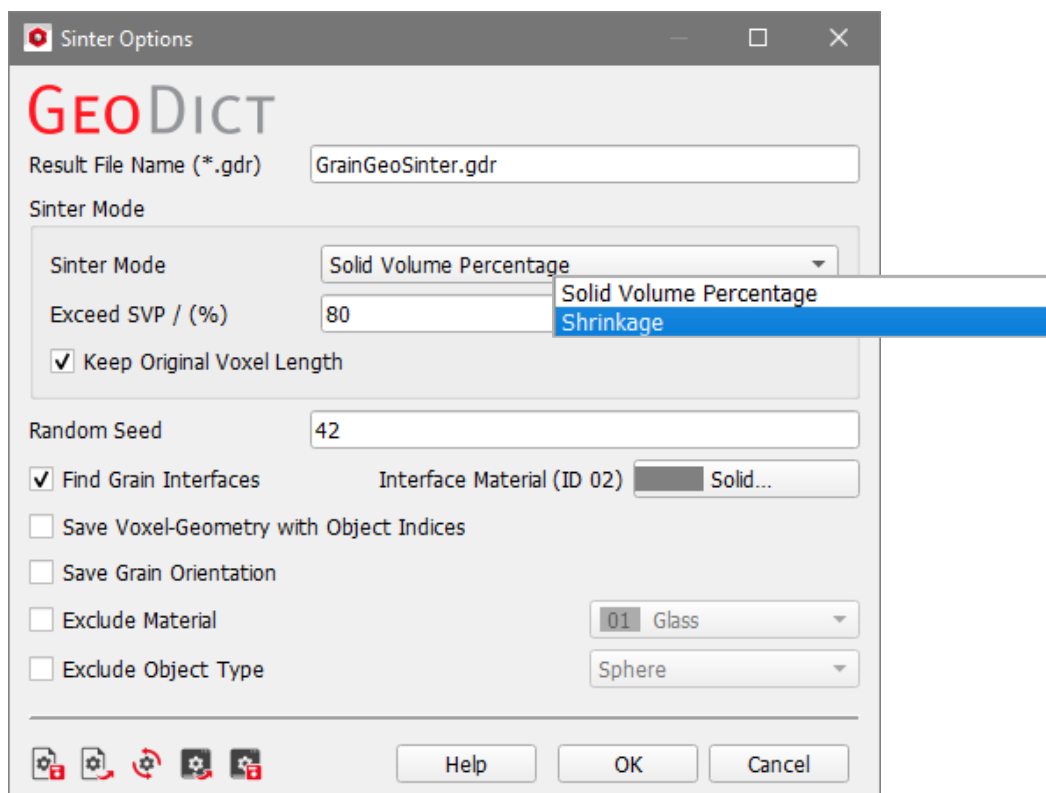

In the **Sinter Options** dialog, several parameters can be entered to control the sintering process: **Sinter Mode**, **Random Seed**, **Find Grain Interfaces**, **Interface Material**, **Save Voxel-Geometry with Object Indices**, **Save Grain Orientation**, and to **Exclude Material**, and **Exclude Object Type** from sintering.

Two different stopping criteria for the sintering process can be defined under the **Sinter Mode** panel:

- **Shrinkage** defines the percentage by which the structure is contracted in each direction.
- **Solid Volume Percentage:** The sintering process continues until the desired Solid Volume Percentage is exceeded (**Exceed SVP**).

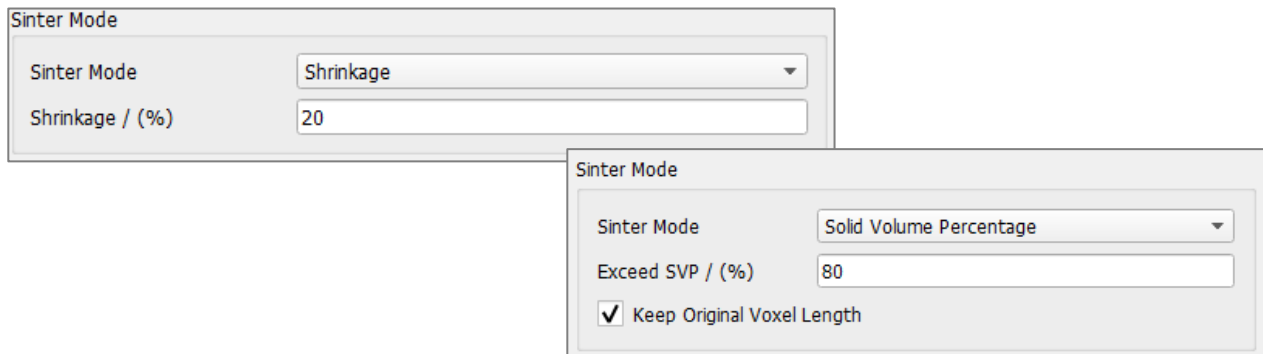

Observe the effect of increasing **Exceed SVP** from 20%, to 40% and then to 60%, when a structure made of convex polyhedrons is sintered.

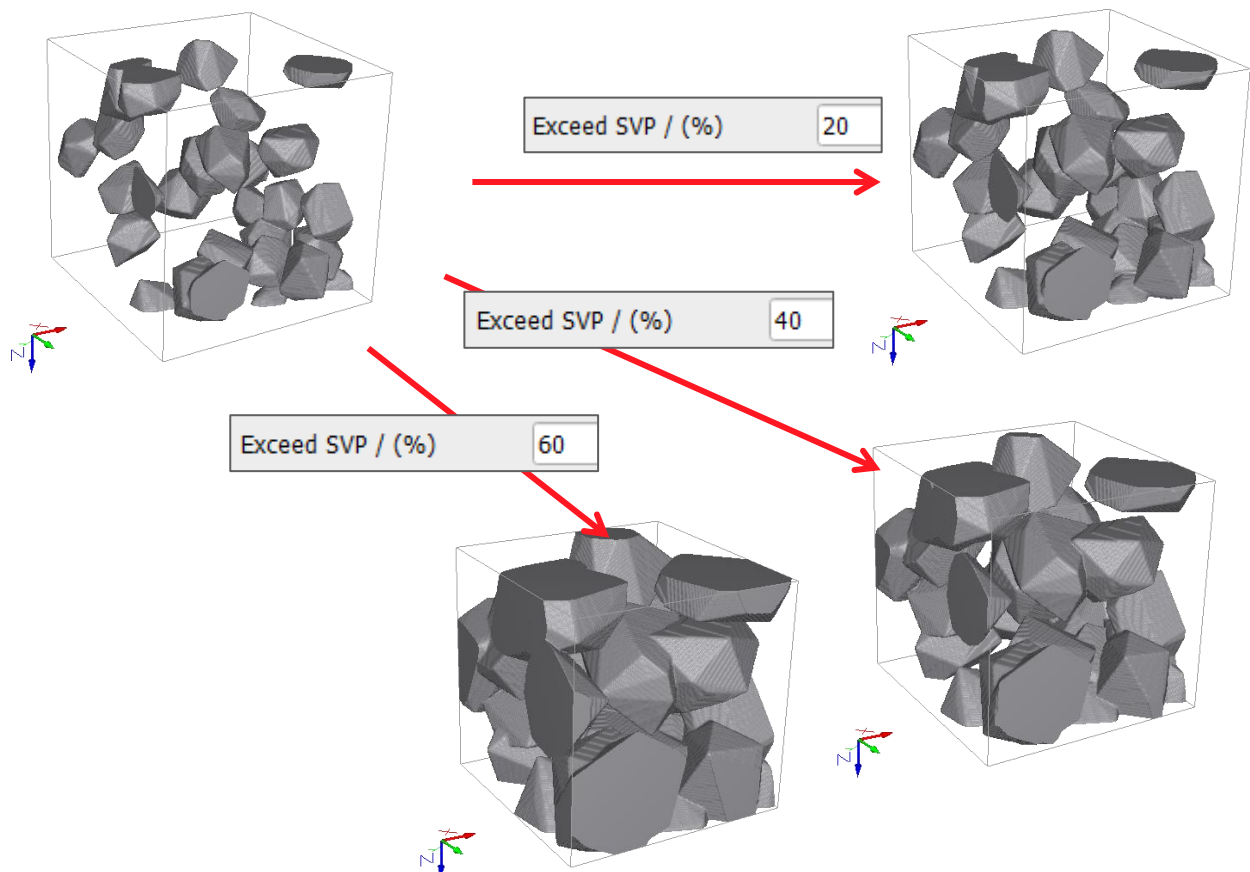

By default, the structure's original voxel length is kept (**Keep Original Voxel Length**), which enlarges the solids. Unchecking this option decreases the voxel length, while the number of voxels remains constant.

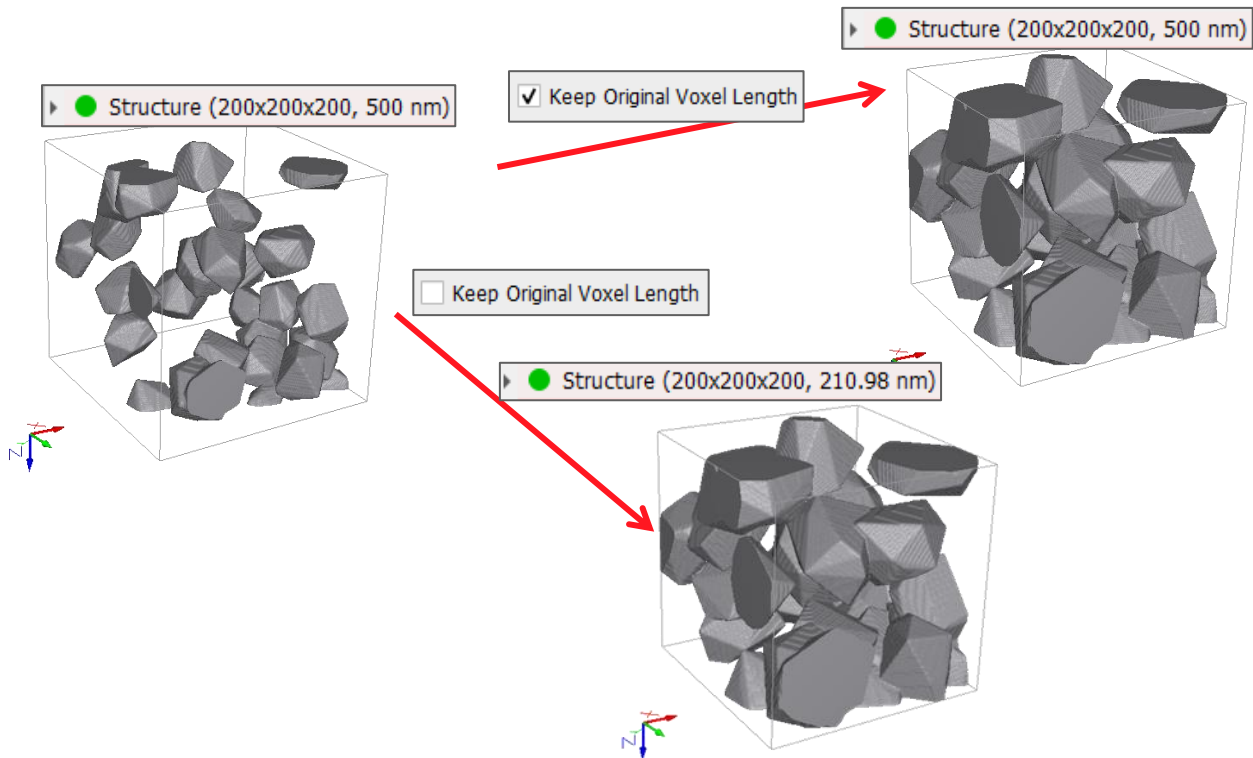

Random Seed is a simulation parameter controlling the sequence in which objects are sintered. Thus, different random seeds lead to slightly different sintered structures. The random seed increases automatically with every sintering process.

If **Find Grain Interfaces** is checked, the **Interface Material** of the sintered objects can be chosen from the GeoDict material database by clicking the button.

By doing so, a different material ID is assigned to the grain interfaces. For example, later mechanical properties can be applied just to the grain interfaces for deformation or other elastic properties simulations with the **ElastoDict** module.

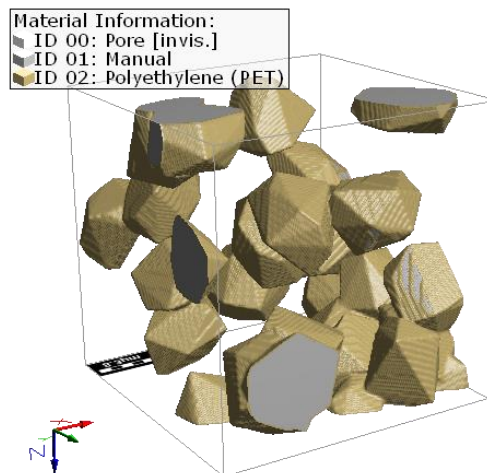
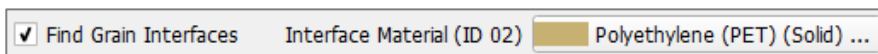

To save the geometry information as binary *.g32 format, check **Save Voxel-Geometry with Object Indices**. The files in *.g32 format are considerably larger than those in GDT format. This file format contains the index of each grain.

To save the available information about the sintered grains in *.gof format, check **Save Grain Orientation**. This file can be used, together with the structure, to compute elastic properties with transversal isotropic or orthotropic constituent materials laws with the **ElastoDict** module.

If generated, these results can be loaded from the **Data Visualization** tab in the Result Viewer.

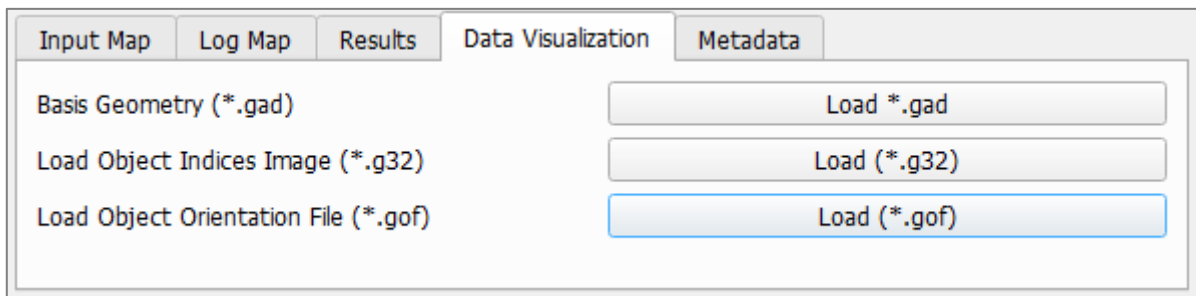

One object material ID and/or one object type per structure can be excluded from the sintering process when checking **Exclude Material** or **Exclude Object Type** and choosing the material ID or the object type name from the pull-down menus.

Exclude Material and **Exclude Type** can be simultaneously selected to exclude objects, that have a certain type or a certain material. For example, exclude all objects with material ID 01 and additionally all spheres.

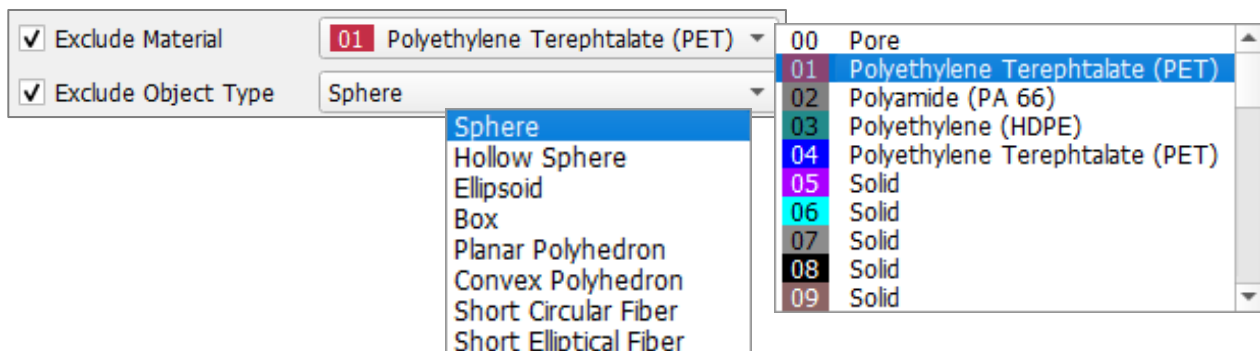

As a simplified example, observe the effect of sequentially excluding the **Material** Polyamide (PA 66), here ID 02 in gray, or the **Object Type** sphere the during a sintering process of three object types made of three different materials.

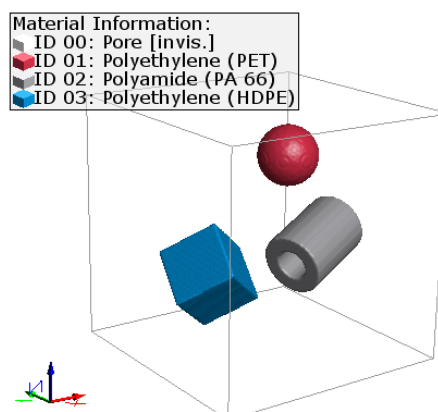

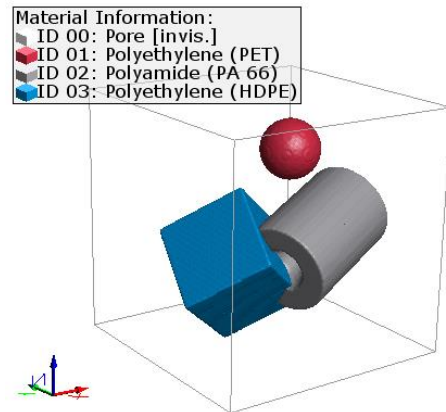
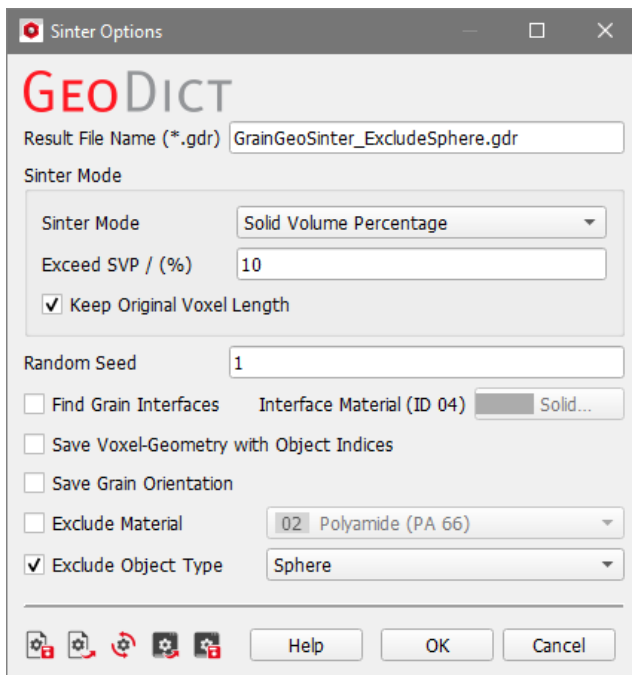
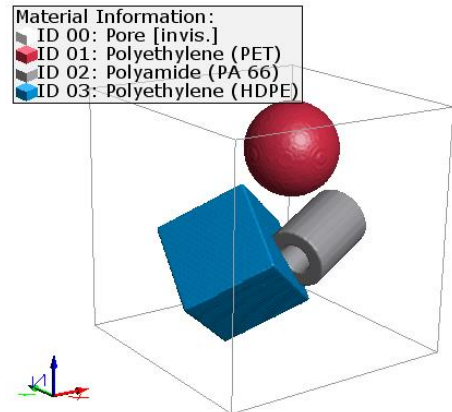
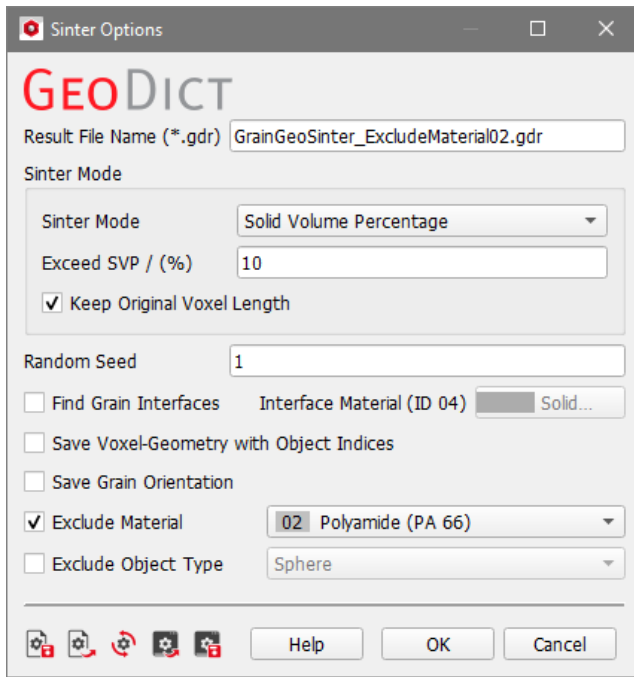

GROW SEDIMENT

When **Grow Sediment** is selected from the pull-down menu in the **GrainGeo** section, layers of a new material (Interface Material) are added to the original structure.

Sediments can only be grown on structures that contain analytic information (GAD format).

Clicking the **Options' Edit...** button opens the **Grow Sediment Options** dialog to enter the desired parameters. Clicking **OK** closes the dialog and returns to the **GrainGeo** section. Clicking **Generate** starts the process of growing sediments on the structure.

A structure containing GAD information must be in memory.

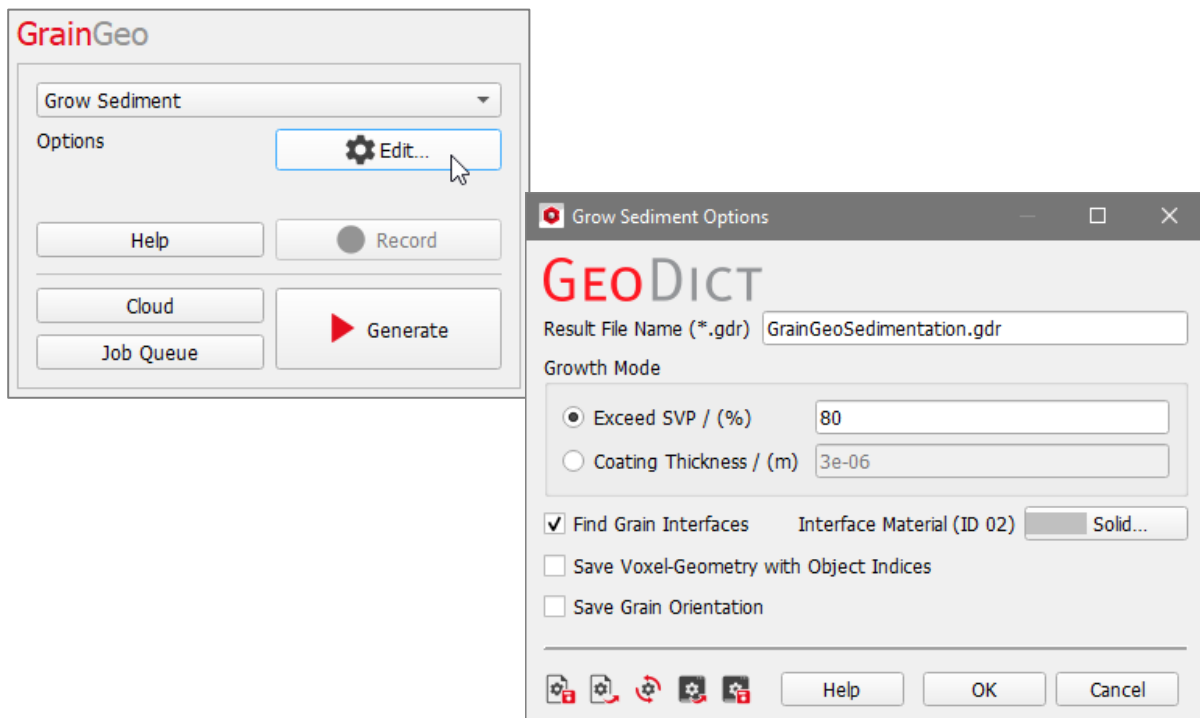

In the Growth Mode panel, select the growth mode between **Exceed SVP (%)** or **Coating thickness (m)**). The **Interface Material** and whether to **Save Voxel-Geometry with Object Indices** and to **Save Grain Orientation** are selected below.

The amount of the added sediment material on the structure can be controlled either by volume percentage (**Exceed SVP**) or by the **Coating Thickness**.

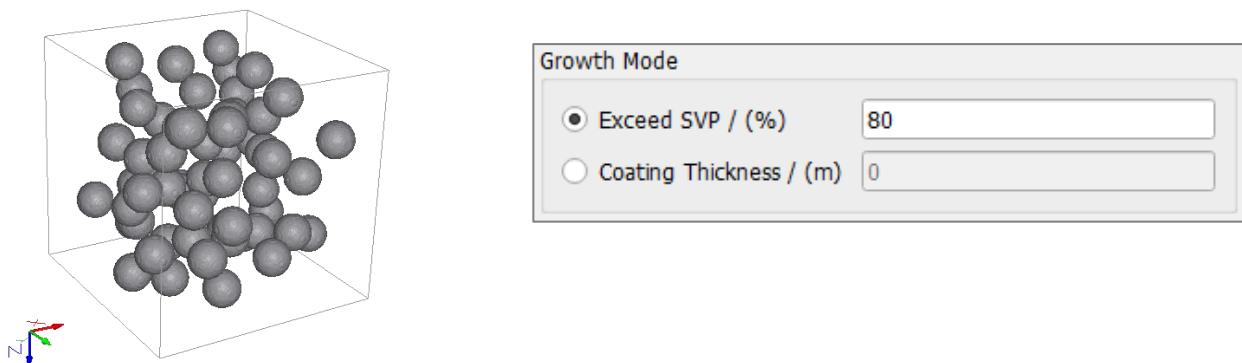

Observe the effect of increasing **Exceed SVP (%)** from 20%, to 60% and then to 90%, when growing sediments on a structure made of spheres.

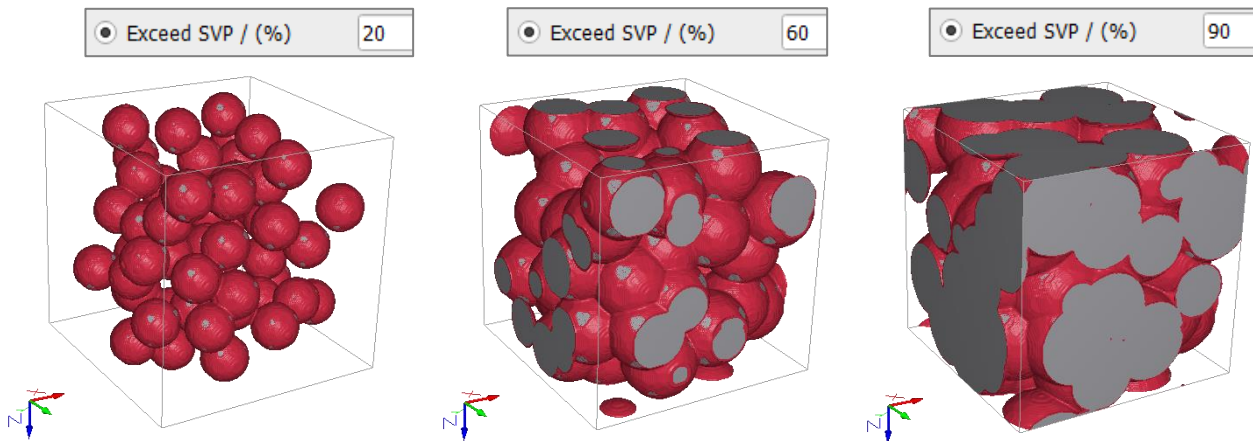

A similar effect is observed when selecting the **Coating Thickness** to be 2.2×10^{-6} m ($2.2 \mu\text{m}$), 1.5×10^{-5} m ($15 \mu\text{m}$), and 2.5×10^{-5} m ($25 \mu\text{m}$).

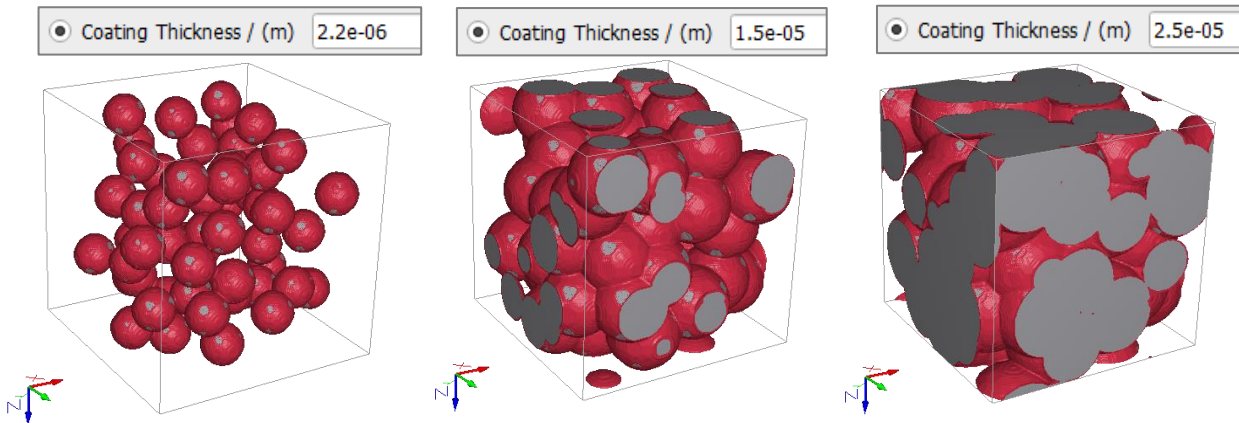

By checking **Find Grain Interfaces** the interfaces are assigned to a new material.

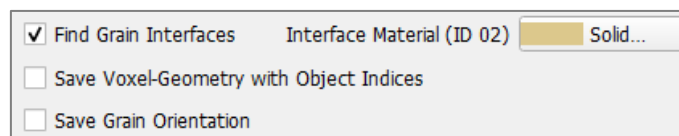

The **Interface Material** of the sediment growing on the structure can be chosen from the GeoDict material database by clicking the button.

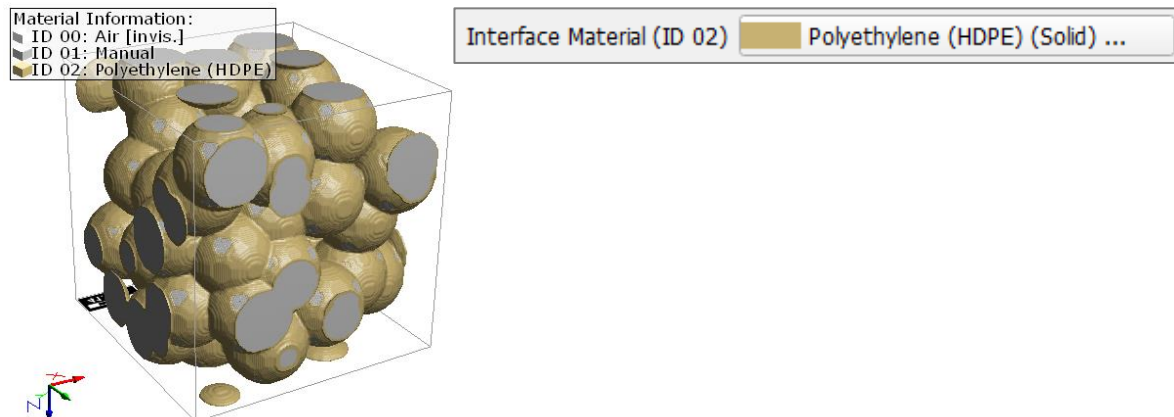

As mentioned above (page [119](#)), the geometry information can be saved as binary in *.g32 format or as human readable ASCII *.leS by checking **Save Voxel-Geometry with Object Indices**. The grain orientation can be saved as *.gof file by checking **Save Grain Orientation**.

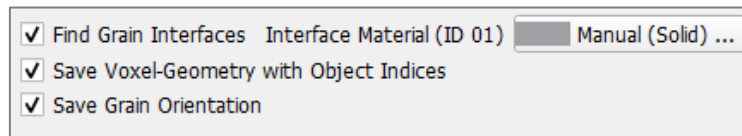

Load the resulting data from the **Data Visualization** tab in the Result Viewer.

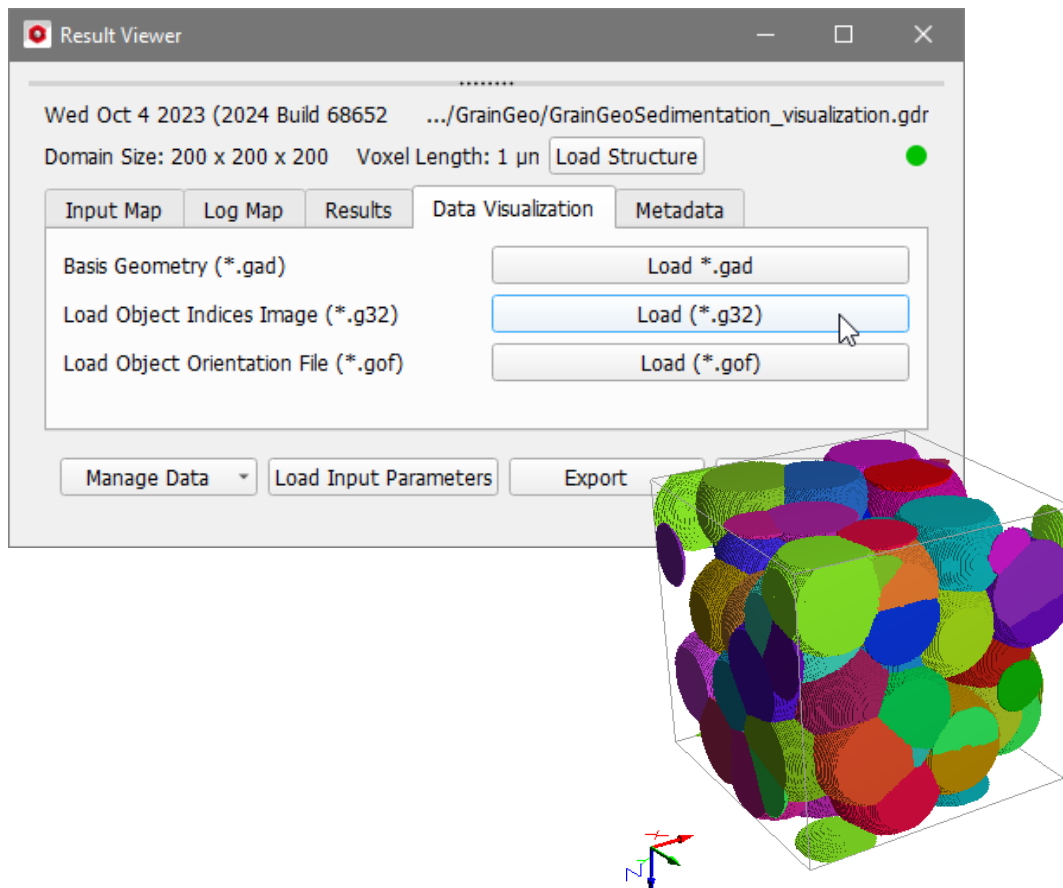

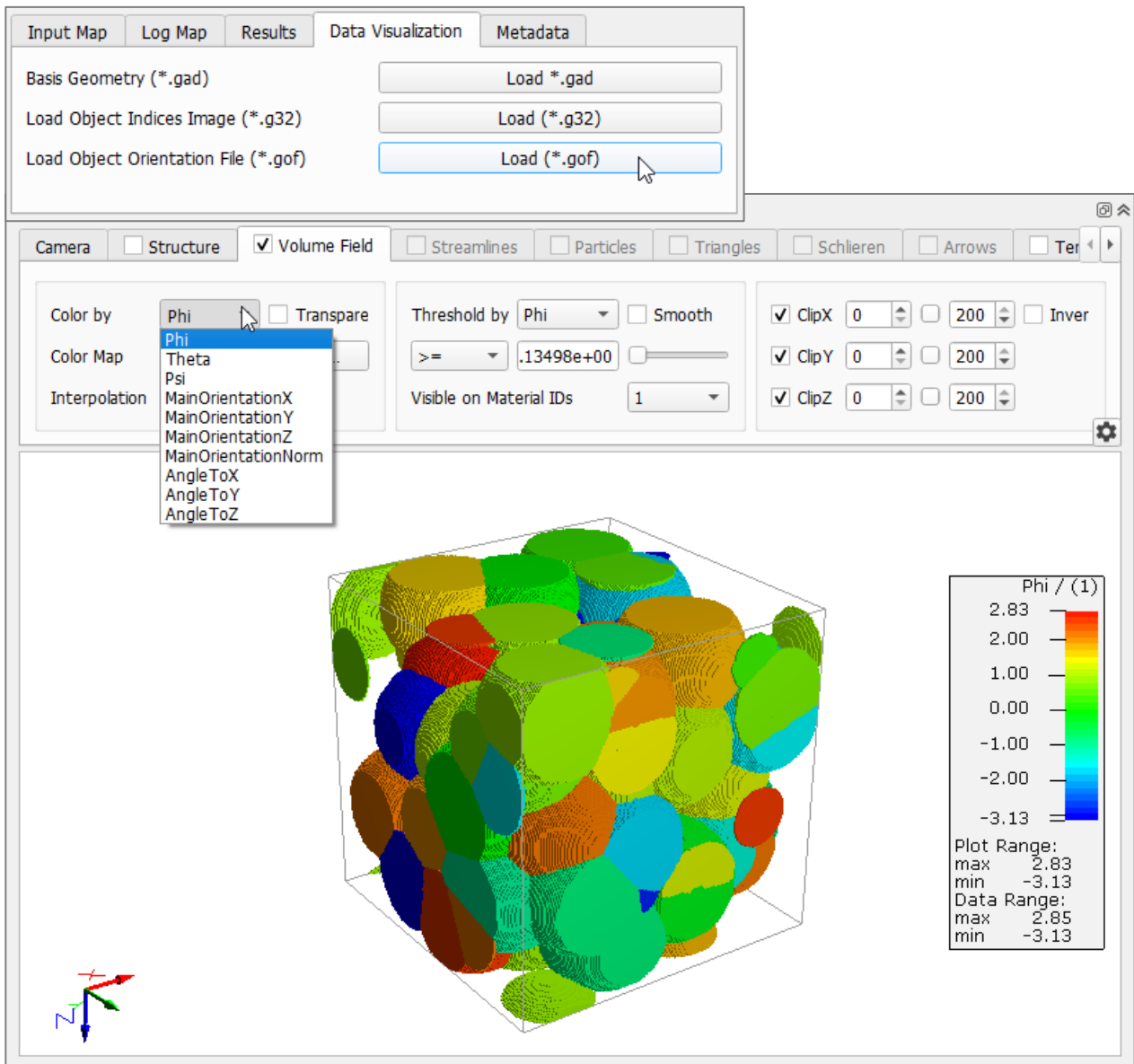

Find more information about visualization of volume fields in the [Visualization handbook](#).

ROUGHEN SURFACE

When choosing **Roughen Surface** from the pull-down menu in the **GrainGeo** section, the structure's surface is roughened. The structure to be roughened must already be in memory.

Clicking the **Options' Edit...** button opens the **Roughen Surface Options** dialog. Clicking **OK** closes the dialog and returns to the **GrainGeo** section. Clicking **Generate** starts the process of surface roughening.

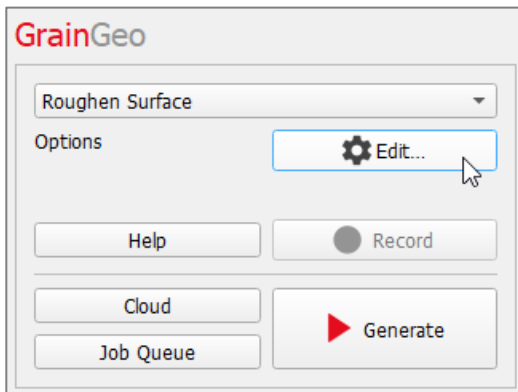

At the top of the **Roughen Surface Options** dialog, the name for the file containing the generation results can be entered in the **Result File Name (*.gdr)** box. The default name can be kept, or a new name can be chosen, fitting the current project. The roughened structure will be saved in the corresponding result folder with the same name.

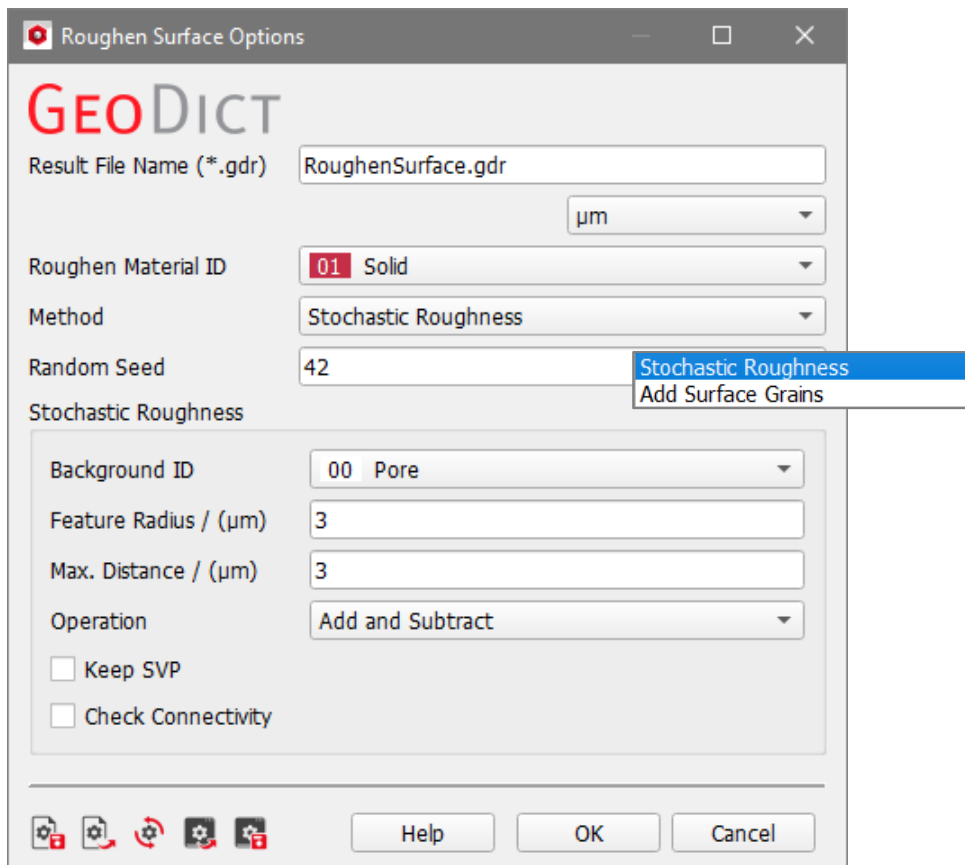

The available units (**m**, **mm**, **µm**, **nm**, and **Voxel**) are selectable below. When the units are changed, the entered values are adjusted automatically.

From the **Roughen Material ID** pull-down menu, choose one material to be roughened from the materials present in the structure. If the structure consists of several materials, each material is treated separately.

Select **Stochastic Roughness** or **Add Surface Grains** as the **Method** to be used for the roughening process from the pull-down menu.

Random Seed initializes the random number generator behind the surface roughening. Changing its value produces different sequences of random numbers and hence, different realizations of the surface roughening. If all settings are equal, generating with the same **Random Seed** value produces the identical roughening.

Stochastic Roughness

Stochastic Roughness roughens the surface of the material ID selected with **Roughen Material ID**. This is done by adding and/or subtracting voxels in the surface following a stochastic distribution.

Only the area where the selected material ID (**Roughen Material ID**) and the **Background ID** touch is defined as surface and thus, roughened. A stochastic field is created and segmented depending on the given parameters. It works similar to the **Stochastic Field Thresholding** described on pages [96ff.](#)

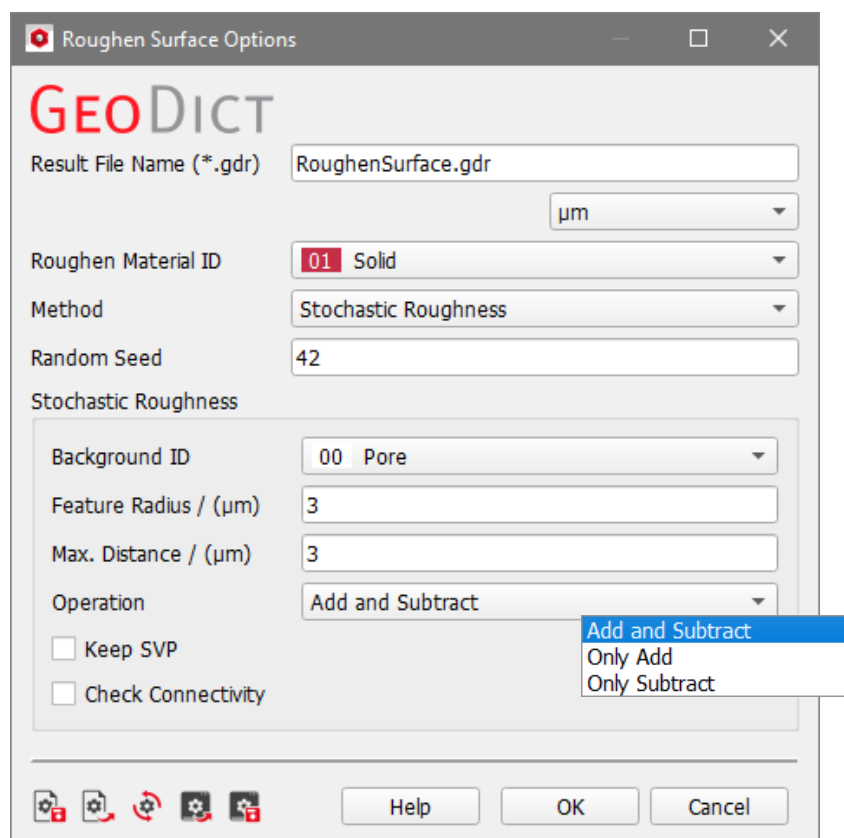

In the **Stochastic Roughness** panel, **Background ID**, **Feature Radius**, **Max. Distance** and **Operation** specify the roughening process.

Change the **Feature Radius** to change the size of the added and subtracted features. The **Feature Radius** is the 99.7 percentile radius of the features, similar to a maximum grain radius.

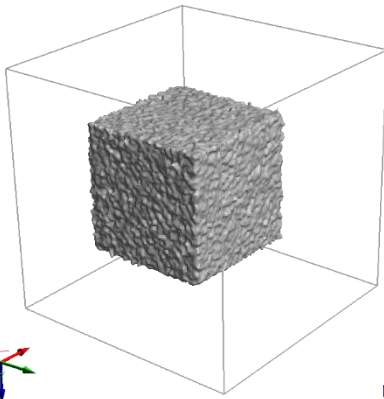
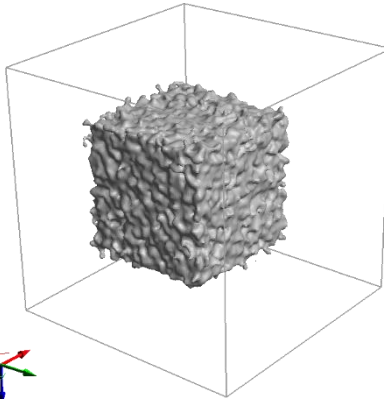
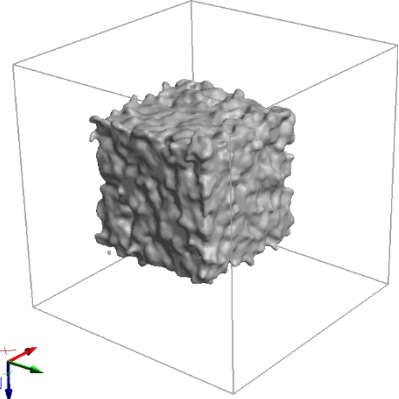
Feature Radius / (μm) 0.5Feature Radius / (μm) 3Feature Radius / (μm) 5

The **Max. Distance** specifies the displacement of the features from the surface, influencing the layer height. If the **Maximum Distance** is chosen higher than the selected **Feature Radius**, not all features are connected to the surface, unless **Check Connectivity** is selected.

This can be observed in the following figure on the last structure with a max distance of 10 μm and a feature radius of 3 μm .

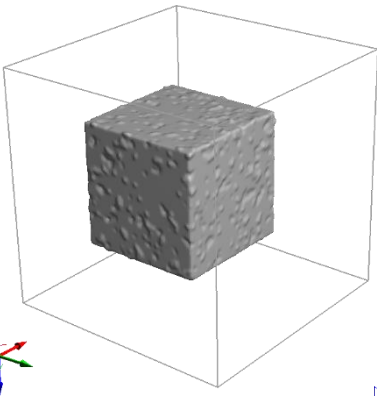
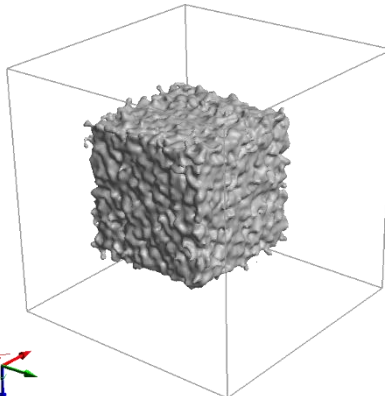
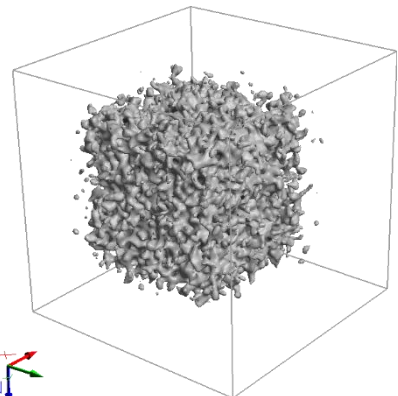
Max. Distance / (μm) 1Max. Distance / (μm) 3Max. Distance / (μm) 10

If **Check Connectivity** is selected, all features will be connected to the original structure.

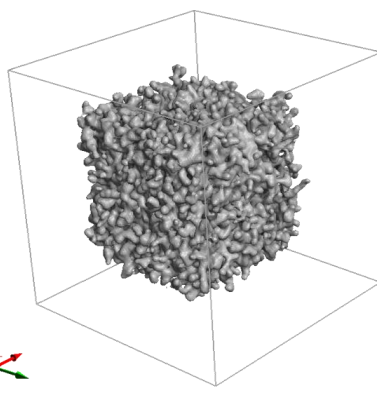
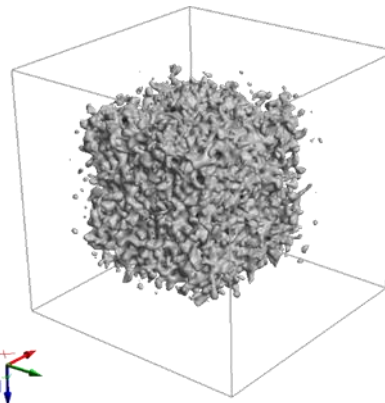
 Check Connectivity Check Connectivity

Select which **Operations** should be allowed for roughening. By default, **Adding and Subtracting** features is allowed. But it is also possible to choose **Only Add** or **Only Subtract** from the pull-down menu.

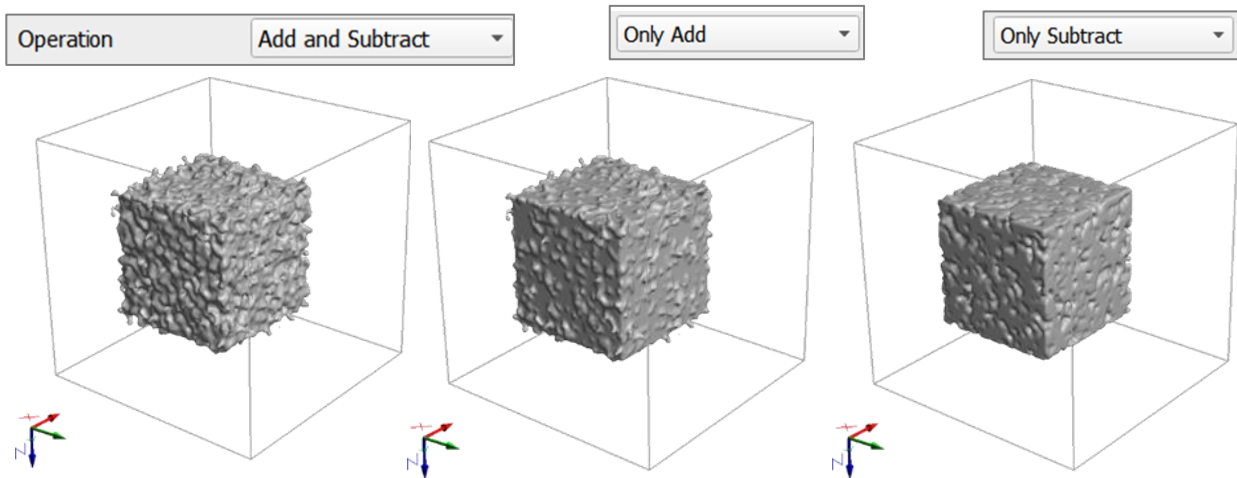

If **Add and Subtract** is selected, the checkbox **Keep SVP** is available. Check to keep the original solid volume percentage of the structure by using the same number of voxels for adding and subtracting.

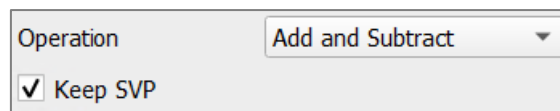

Add Surface Grains

Add Surface Grains roughens the surface by adding grains on the surface of the material ID selected with **Roughen Material ID**.

The next available ID is assigned to the grains and the material of the grains can be selected from the database after clicking the button. For example, if the structure contains one material with material ID 01, the grains are assigned to material ID 02.

The parameters **Number of Grains** per volume (given in $1/m^3$) and **Radius** define the number of grains added to the domain and the size of the grains added to a certain material in the domain.

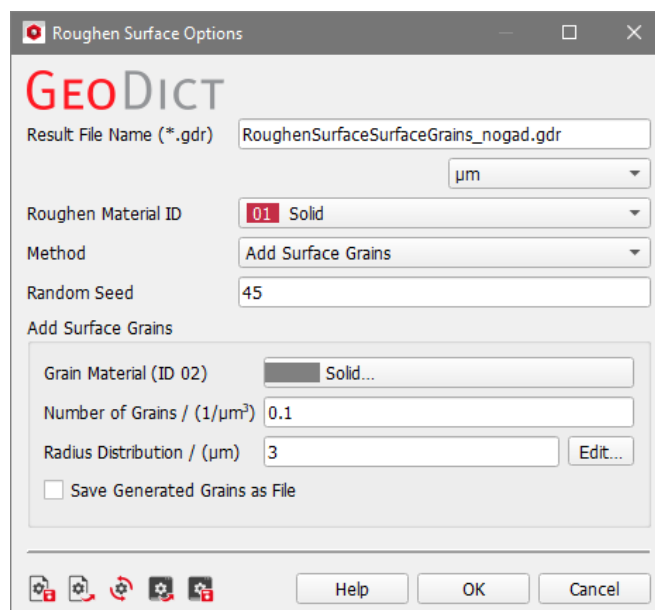

By clicking the **Edit...** button, the **Radius Distribution** of the grains can be set to be a **Constant** value, or to follow a distribution (**Uniformly in interval**, **Gaussian**, **Probability Distribution**, or **Log-Normal**) as seen above for other parameters (see pages [32ff](#)).

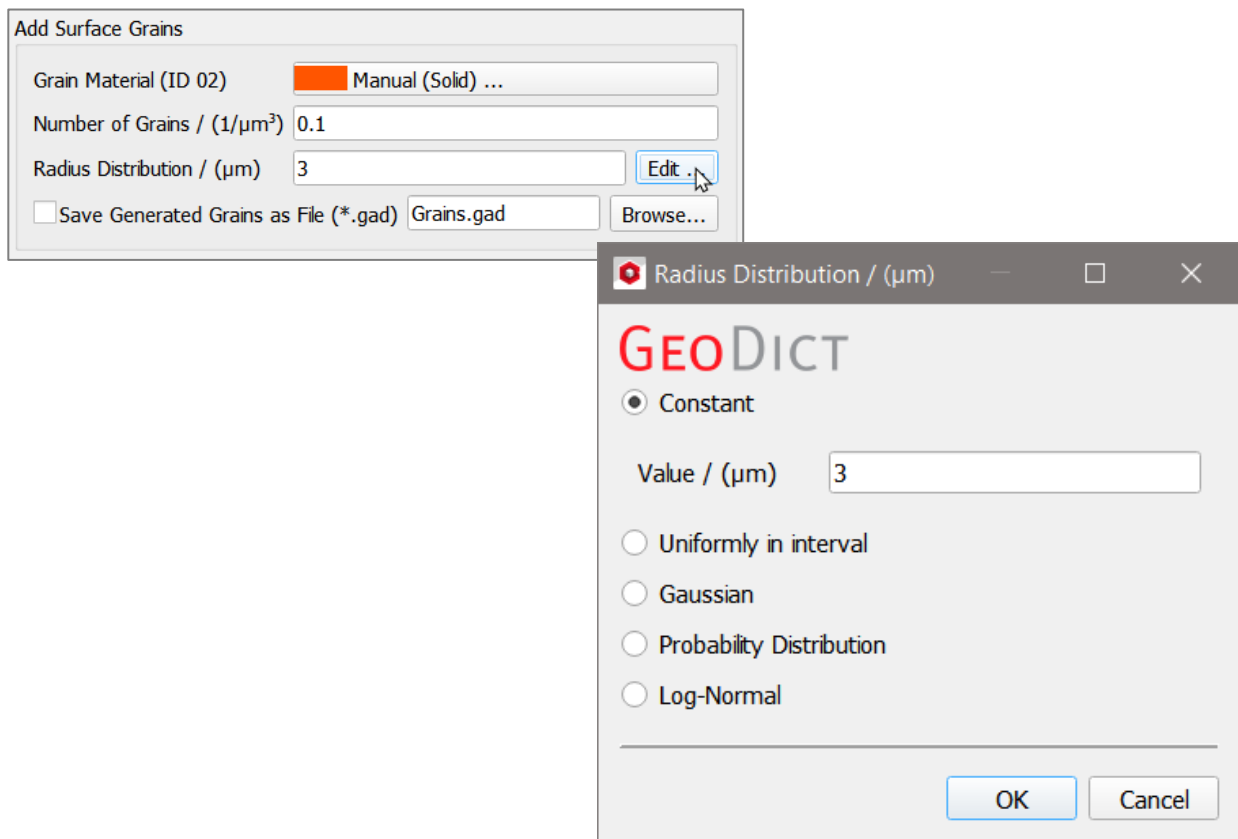

When **Save Generated Grains** is selected, the added surface grains are saved as **SurfaceGrains.gad** structure file in the result folder. This file contains the grains' analytic data.

As a simplified example, observe the addition of grains with radius 2 μm to objects (box and sphere) with different material IDs. The grains are added in two steps, first to material ID 01 (box), and then to material ID 02 (sphere).

The **Number of Grains** added is 0.1 grain/ μm^3 (1 grain for every 10 μm^3 of the domain).

For each roughening step, a new GAD file for the grains can be saved, for example with the names grains1.gad and grains2.gad.

Material Information:
 ID 00: Air [invis.]
 ID 01: Polyethylene (PET)
 ID 02: Polyethylene (PET)

Settings Dialog 1:
 Roughen Material ID: 01 Polyethylene Terephthalate (PET)
 Method: Add Surface Grains
 Random Seed: 42
 Add Surface Grains
 Grain Material (ID 03): Solid...
 Number of Grains / (1/μm³): 0.1
 Radius Distribution / (μm): 2 Edit...
 Save Generated Grains as File

Material Information:
 ID 00: Air [invis.]
 ID 01: Polyethylene (PET)
 ID 02: Polyethylene (PET)
 ID 03: Solid

Settings Dialog 2:
 Roughen Material ID: 02 Polyethylene Terephthalate (PET)
 Method: Add Surface Grains
 Random Seed: 43
 Add Surface Grains
 Grain Material (ID 04): Solid...
 Number of Grains / (1/μm³): 0.1
 Radius Distribution / (μm): 2 Edit...
 Save Generated Grains as File

Material Information:
 ID 00: Air [invis.]
 ID 01: Polyethylene (PET)
 ID 02: Polyethylene (PET)
 ID 03: Solid
 ID 04: Solid

Observe now the effect of adding different amounts of grains with a radius of 3 μm to a cube.

Number of Grains / ($1/\mu\text{m}^3$)
Radius Distribution / (μm)

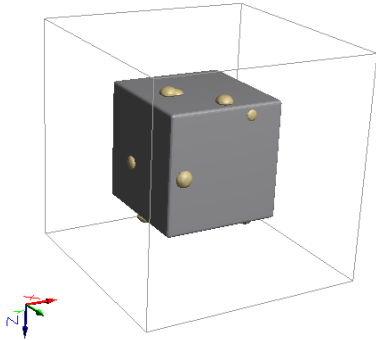

Number of Grains / ($1/\mu\text{m}^3$)
Radius Distribution / (μm)

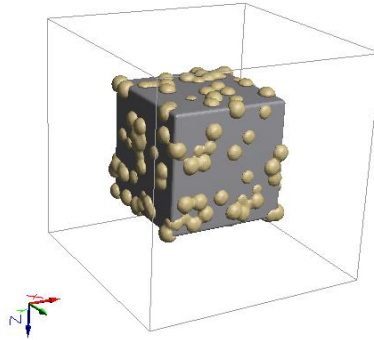

Number of Grains / ($1/\mu\text{m}^3$)
Radius Distribution / (μm)

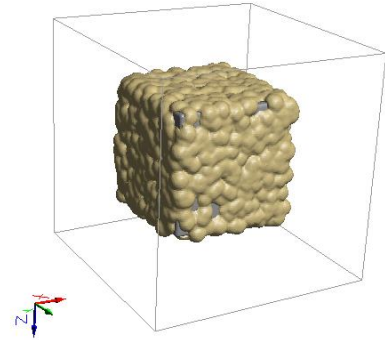

Finally, observe the effect of always adding $0.1/\mu\text{m}^3$ grains of different radius (1 μm , 2 μm , or 2.5 μm) to the cube.

Number of Grains / ($1/\mu\text{m}^3$)
Radius Distribution / (μm)

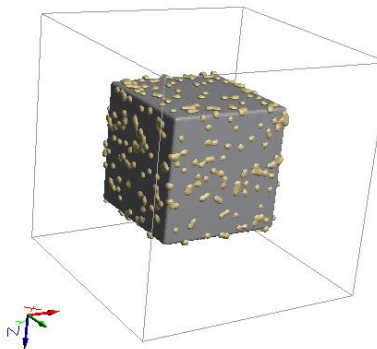

Number of Grains / ($1/\mu\text{m}^3$)
Radius Distribution / (μm)

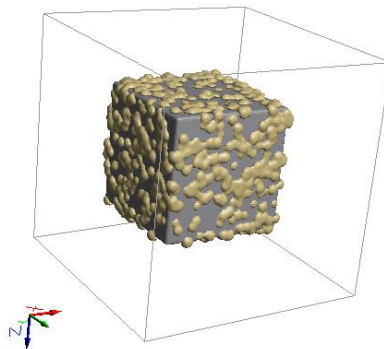

Number of Grains / ($1/\mu\text{m}^3$)
Radius Distribution / (μm)

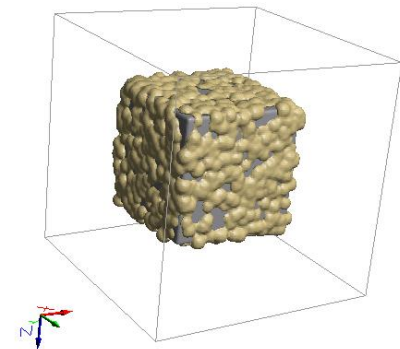

ADD BINDER

Binder provides structural integrity to structures with grains of all shapes and is, therefore, an important processing additive for battery electrodes, grain packs, ceramics, and hard-metal sintering processes.

Add Binder to a structure consists of adding material in the shape of a concave meniscus in locations where surfaces in that structure’s material are close together.

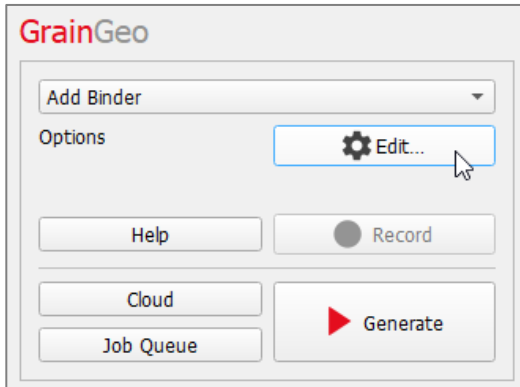

For hollow objects, such as hollow spheres, short hollow fibers, and short cellulose fibers the algorithm behind needs analytic data (*.**Add Binder** gad format) to discern that the empty voxels inside these objects are not part of the pore space. Without analytic data, i.e. when using voxelized models (*.gdt format), binder is also added inside the hollow objects, which is physically inaccurate.

Clicking the **Options’ Edit...** button opens the **Add Binder** dialog. Clicking **OK** closes the dialog and returns to the **GrainGeo** section. Clicking **Generate** starts the process.

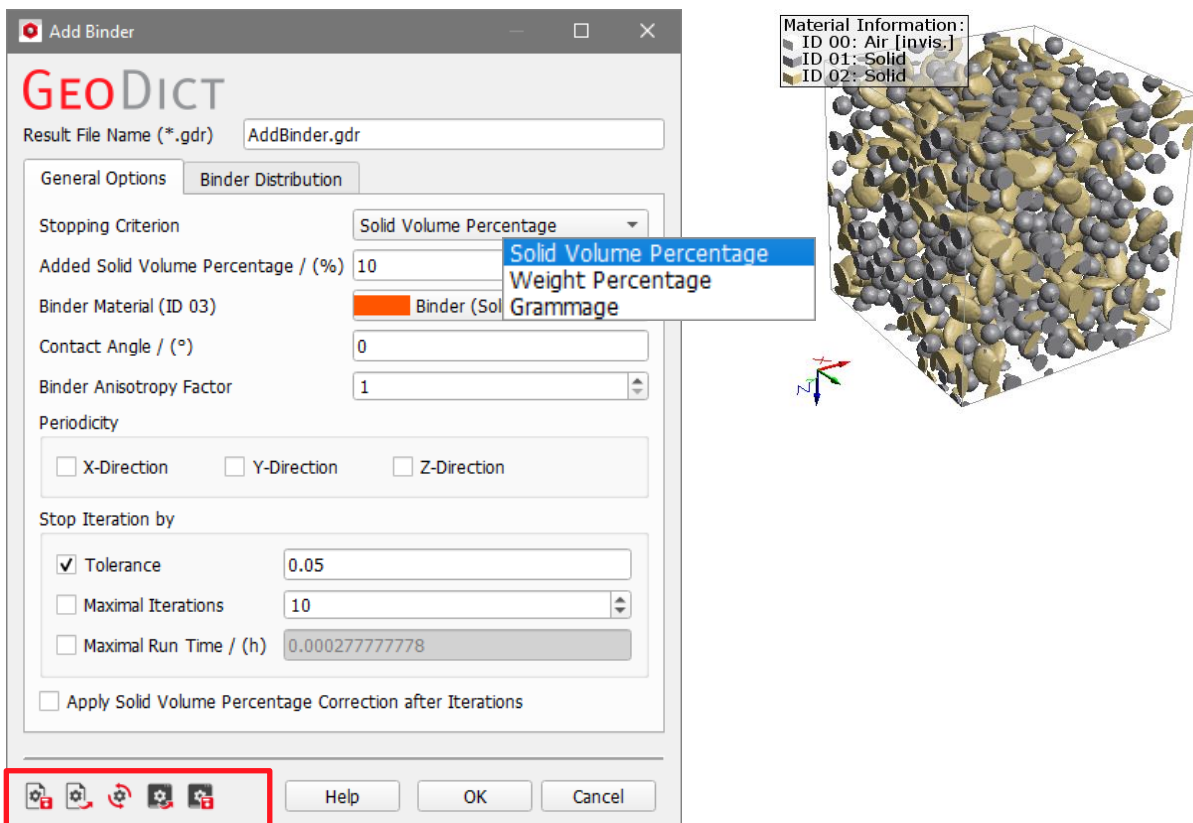

At the top of the **Add Binder** dialog, the name for the file containing the results of adding binder can be entered in the **Result File Name (*.gdr)** box. The default name can be kept, or a new name can be chosen.

The options are organized into **General Options** and **Binder Distribution** accessible through tabs.

GENERAL OPTIONS

STOPPING CRITERION

The user may choose the most appropriate stopping criterion when adding binder. The chosen **Stopping Criterion** interrupts the addition of binder when it is reached. The available stopping criteria are **Solid Volume Percentage**, **Weight Percentage**, and **Grammage**.

Solid Volume Percentage

The binder volume reaches a pre-established **Added Solid Volume Percentage (%)** relative to the total volume. The added material is displayed as a volume amount deposited on the structure.

The **Binder Material** is assigned to the next available material ID, and the appropriate material to be used as binder should be selected from the material database by clicking the button.

The screenshot shows the 'Binder Distribution' tab of the 'Add Binder' dialog. The 'Stopping Criterion' is set to 'Solid Volume Percentage'. The 'Added Solid Volume Percentage / (%)' is set to 10. The 'Binder Material (ID 02)' is set to 'Manual (Solid) ...'. The 'Contact Angle / (°)' is set to 0. The 'Binder Anisotropy Factor' is set to 1.

General Options	Binder Distribution
Stopping Criterion	Solid Volume Percentage
Added Solid Volume Percentage / (%)	10
Binder Material (ID 02)	Manual (Solid) ...
Contact Angle / (°)	0
Binder Anisotropy Factor	1

Weight Percentage

The weight of binder reaches a certain percentage of the weight of material.

As seen above for the Solid Volume Percentage stopping criterion, the **Binder Material** is assigned to the next available material ID, and the appropriate **Binder Material** should be selected from the material database by clicking the button.

The screenshot shows the 'Binder Distribution' tab of the 'Add Binder' dialog. The 'Stopping Criterion' is set to 'Weight Percentage'. The 'Binder Weight Percentage / (%)' is set to 20. The 'Binder Material (ID 02)' is set to 'Manual (Solid) ...'. The 'Material Density / (g/cm³)' is set to 1. The 'Binder Density / (g/cm³)' is set to 2.7. The 'Contact Angle / (°)' is set to 0. The 'Binder Anisotropy Factor' is set to 1.

General Options	Binder Distribution
Stopping Criterion	Weight Percentage
Binder Weight Percentage / (%)	20
Binder Material (ID 02)	Manual (Solid) ...
Material Density / (g/cm³)	1
Binder Density / (g/cm³)	2.7
Contact Angle / (°)	0
Binder Anisotropy Factor	1

It is necessary to set the density for the structure's material (**Material Density**) and for the binder material (**Binder Density**) both in g/cm^3 , as well as the desired (weight) percentage of binder material to structure material (**Binder Weight Percentage**, in %). That is, a **Binder weight percentage** of 20 means that there are 20 g of binder added per 100 g of objects in the structure.

In the following example, two types of binder (high density: 5 g/cm^3 and low density: 0.5 g/cm^3) are added to structure material with a density of 5 g/cm^3 .

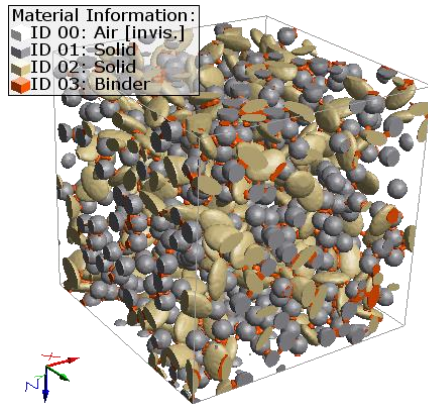

Stopping Criterion	Weight Percentage
Binder Weight Percentage / (%)	20
Binder Material (ID 03)	Manual (Solid) ...
Material Density / (g/cm^3)	1
Binder Density / (g/cm^3)	3
Contact Angle / ($^\circ$)	0
Binder Anisotropy Factor	1

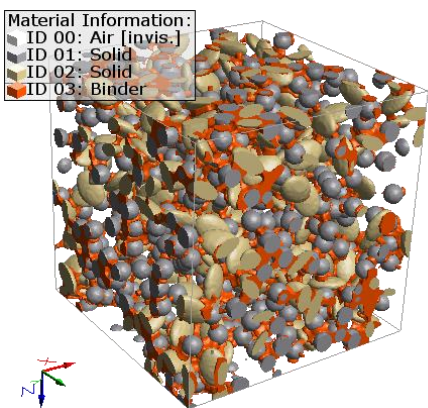

Stopping Criterion	Weight Percentage
Binder Weight Percentage / (%)	20
Binder Material (ID 03)	Manual (Solid) ...
Material Density / (g/cm^3)	1
Binder Density / (g/cm^3)	0.9
Contact Angle / ($^\circ$)	0
Binder Anisotropy Factor	1

For Weight Percentage, when **Manual** or **Undefined** are selected, the density of the binder is not automatically taken from the database and the user must enter it manually (**Binder Density [g/cm^3]**). If this binder material should often be entered by the user, it may be saved in the user's personal database to be selected just by a single click.

Grammage

The addition of binder stops when the **Added Grammage** (material and binder, g/m^2) is reached.

General Options		Binder Distribution
Stopping Criterion	Grammage	
Added Grammage / (g/m^2)	10	
Binder Material (ID 02)	Manual (Solid) ...	
Binder Density / (g/cm^3)	2.7	
Contact Angle / ($^\circ$)	0	
Binder Anisotropy Factor	1	

As seen above for the Solid Volume Percentage stopping criterion, the **Binder Material** is assigned to the next available material ID and the appropriate material to be used as binder should be selected from the material database by clicking the button.

For **Grammage**, when **Manual** or **Undefined** are selected, the density of the binder is not automatically taken from the database and the user must enter it manually (**Binder Density [g/cm³]**). If a manual material is used frequently, it is useful to save it to the material database.

CONTACT ANGLE

The **Contact Angle** defines the angle in which the binder is deposited in relation to the materials in the structure. Values between 0° and 60° are accepted. The contact angle helps to optimize and realistically model the addition of binder.

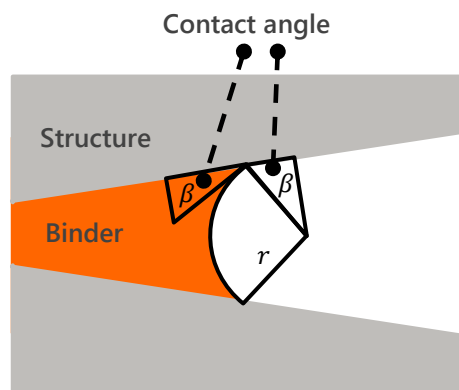

Observe the effect of adding binder with a **Contact Angle** of 0°,

Stopping Criterion	Solid Volume Percentage
Added Solid Volume Percentage / (%)	5
Binder Material (ID 03)	Manual (Solid) ...
Contact Angle / (°)	0
Binder Anisotropy Factor	1

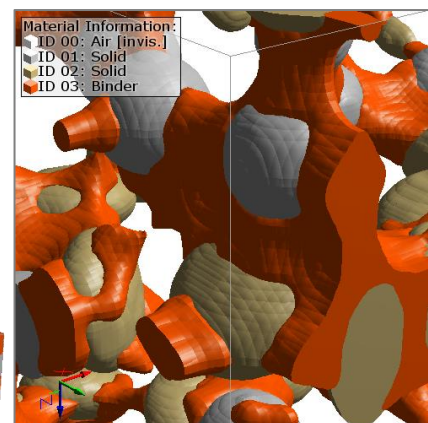
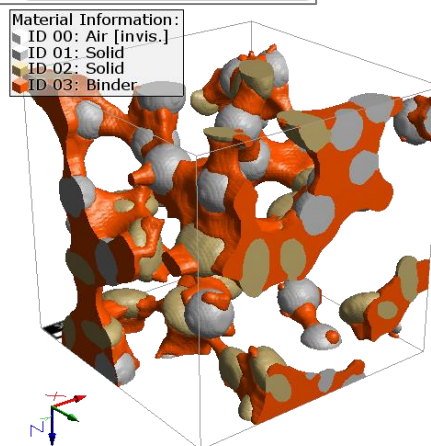

or a **Contact Angle** of 45°.

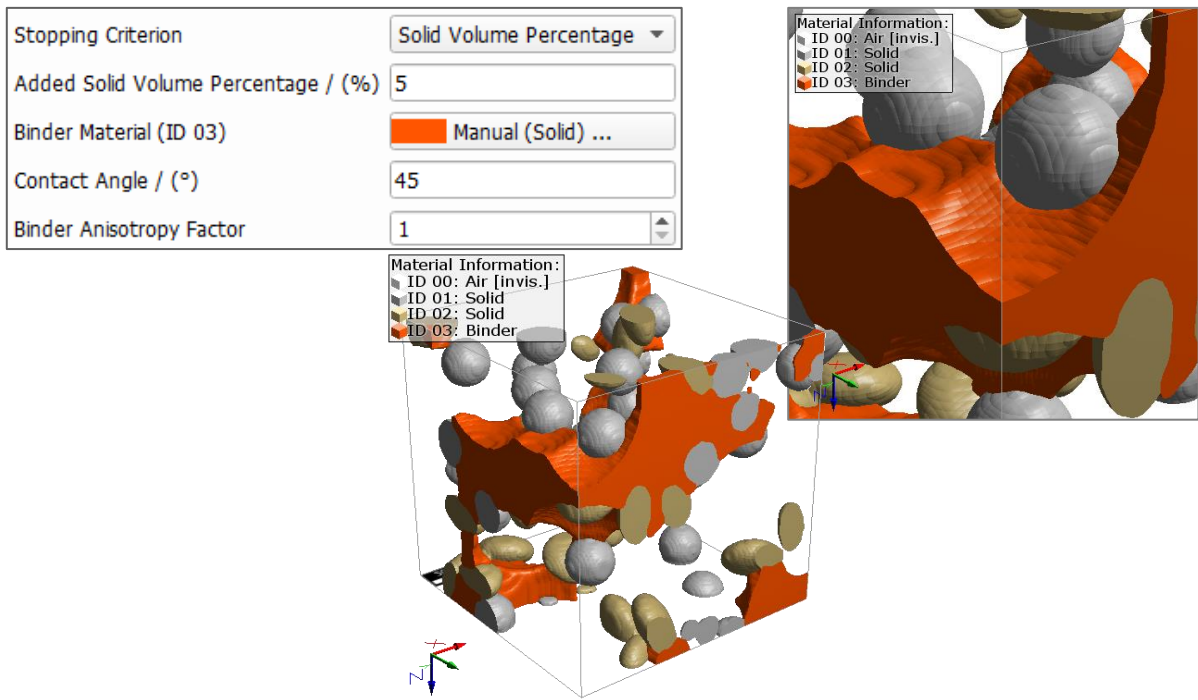

BINDER ANISOTROPY FACTOR

Through the **Binder Anisotropy Factor**, the user exerts fine control over the variation of properties brought on by the addition of the binder due to the variation in direction. If the factor is the default value of 1, the binder is distributed isotropically. By choosing larger values, the binder is distributed in the XY-plane but then, the contact angle value is not accurate anymore.

Observe the effect of changing the **Binder Anisotropy Factor** from (the default) 1 to 3 when adding binder in the direction of the XY-plane.

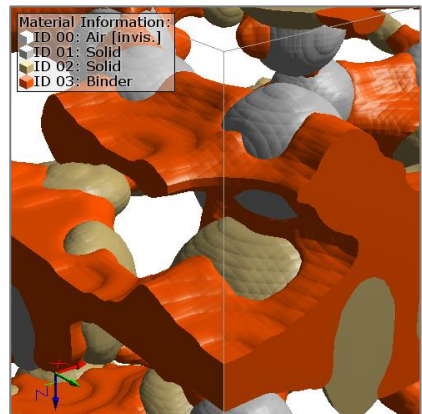
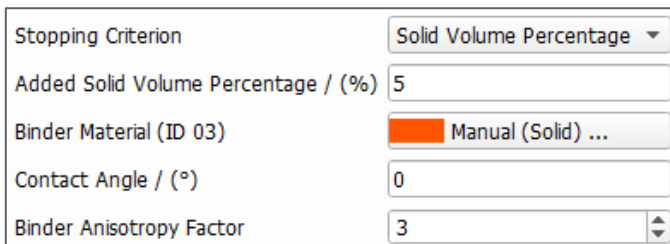
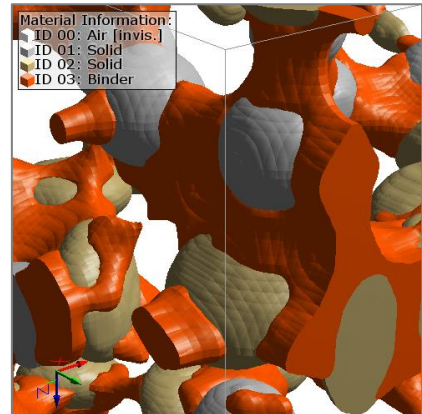
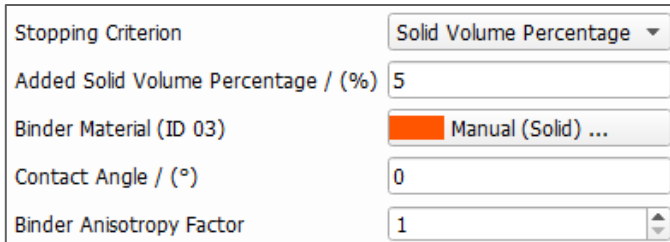

PERIODICITY

When the 3D-structure model is periodic in one or more directions, the binder can be added periodically: in all directions, only in the selected direction (**Periodic X**, **Periodic Y** and/or **Periodic Z**), or non-periodically. Adding binder periodically in certain direction(s) only makes sense if the 3D-structure model is periodic in that/those direction(s).

STOP ITERATION BY

GrainGeo adds binder through an iterative process, which is repeated until the stopping criteria is fulfilled.

The stopping of the iterative process is controlled by checking and setting values and for **Tolerance**, **Maximal Iterations**, or **Maximal Run Time (h)**.

Tolerance is the allowable amount of absolute variation between the entered target value for the selected stopping criterion (Solid Volume Percentage, Weight Percentage, or Grammage) and the value reached by the algorithm.

The user may also choose to have the addition of binder stop by a certain number of **Maximal Iterations** or **Maximal Run Time (h)**.

Information on the stopping of the iterations and the number of iterations can be found in the Result Viewer of the *.gdr result file.

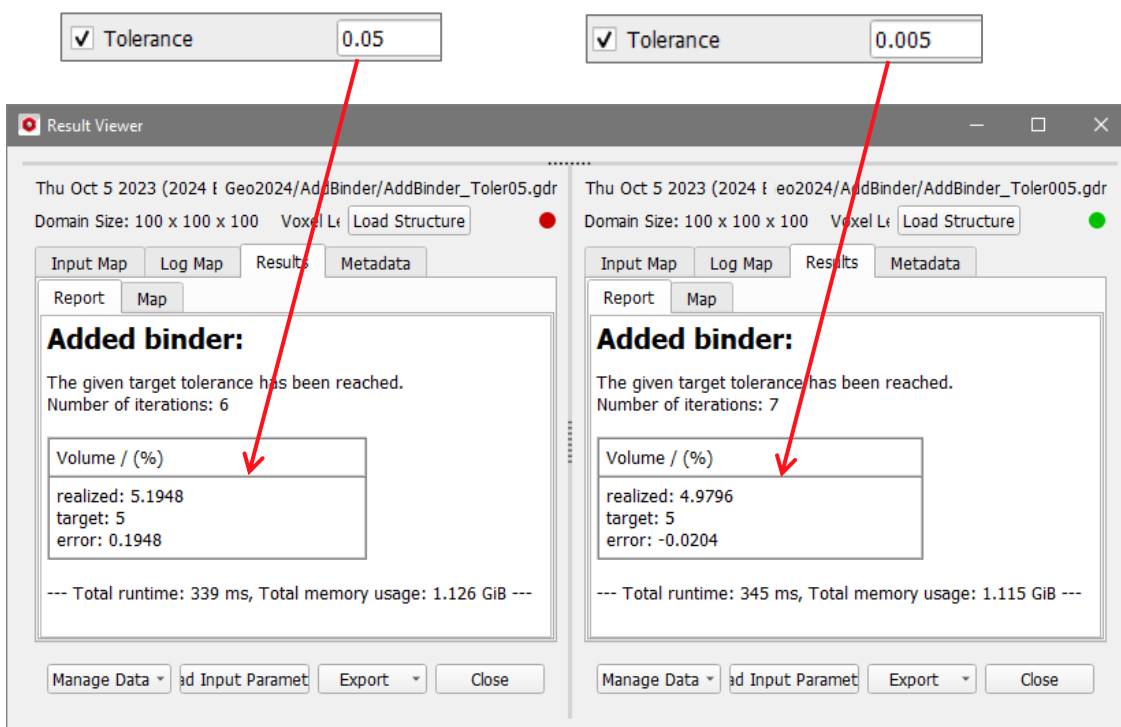

APPLY SOLID VOLUME PERCENTAGE / WEIGHT PERCENTAGE / GRAMMAGE CORRECTION AFTER ITERATIONS

Adding binder with the algorithm adds binder until the iteration stops according to the given stopping criterions. Thus, the given value for **Solid Volume Percentage / Weight Percentage / Grammage** is usually not reached precisely and there are few cases, where the algorithm even does not converge.

If the amount of binder should be reached perfectly, it can be corrected, by checking **Apply Solid Volume Percentage Correction after Iterations**, **Apply Weight Percentage Correction after Iterations** or **Apply Grammage Correction after Iterations** depending on the chosen stopping criterion.

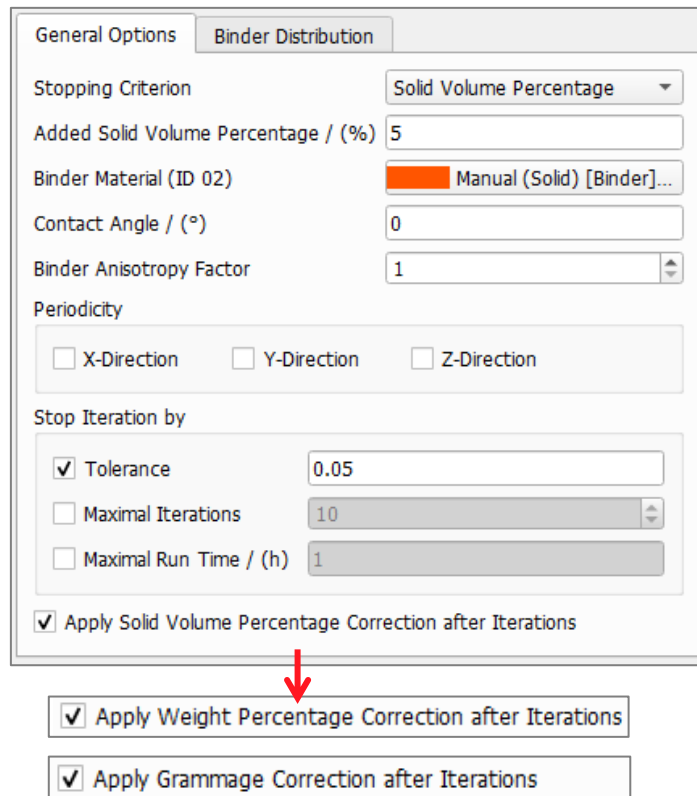

Selecting this option adds or removes binder surface voxels after the iterations are stopped until the given binder value is reached precisely.

Note, that this reduces the **Contact Angle** precision

If the realized amount of binder after the iterations is larger than the target value, voxels are removed from exposed positions, i.e. voxels with only one contact to another binder voxel.

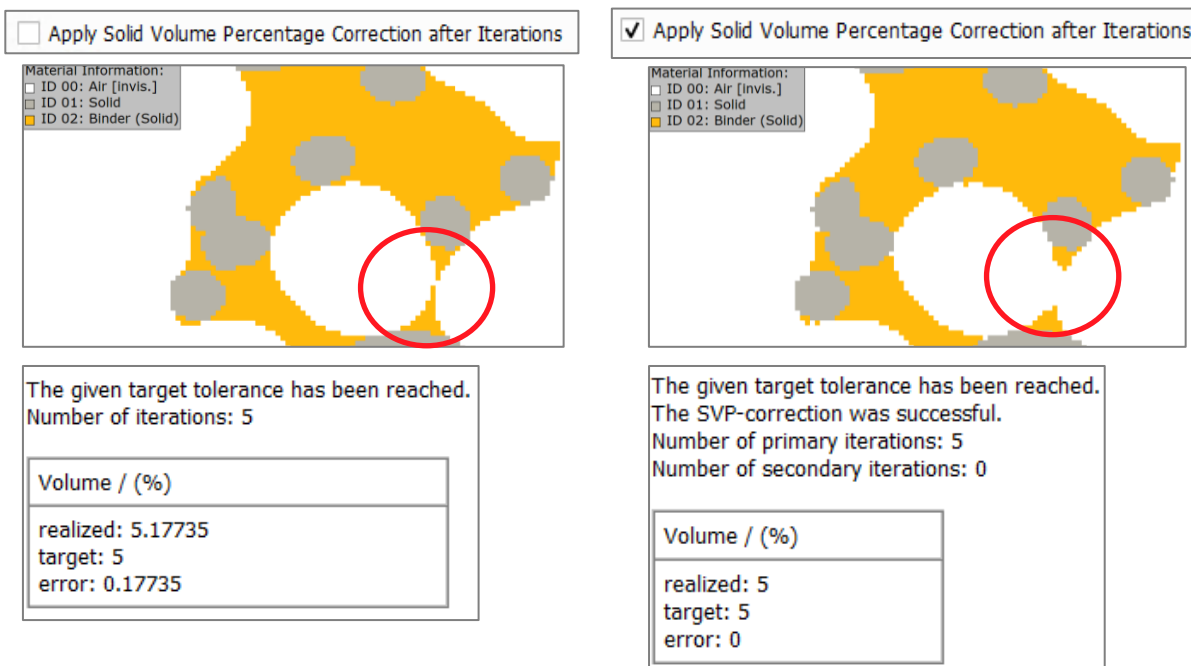

In the other case, if the amount of binder is smaller than the target value, the algorithm adds voxels on positions with the most binder voxel neighbors.

Apply Solid Volume Percentage Correction after Iterations

Material Information:
 ID 00: Air [Invis.]
 ID 01: Solid
 ID 02: Binder (Solid)

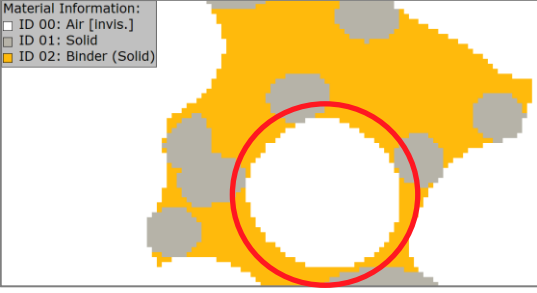

The given target tolerance has been reached.
Number of iterations: 7

Volume / (%)
realized: 5.61852
target: 5.8
error: -0.181475

Apply Solid Volume Percentage Correction after Iterations

Material Information:
 ID 00: Air [Invis.]
 ID 01: Solid
 ID 02: Binder (Solid)

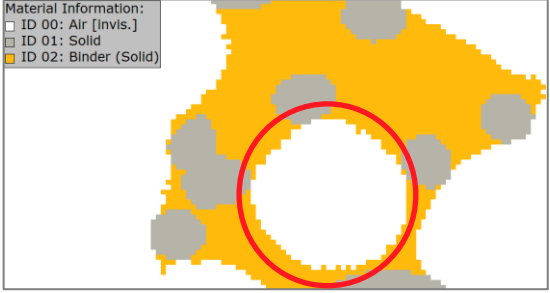

The given target tolerance has been reached.
The SVP-correction was successful.
Number of primary iterations: 7
Number of secondary iterations: 3

Volume / (%)
realized: 5.8
target: 5.8
error: 0

In detail, the algorithm applies small dilations and erosions to keep a smooth surface. In detail four steps are performed:

1. First, a voxel-zone at the surface is defined by the smallest possible dilation / erosion.
2. Within this voxel zone the algorithm again applies dilations / erosions. This reduces the voxel zone further.
3. Afterwards only a small surface layer remains that is maximal one voxel thick.
4. These remaining voxels are randomly reassigned.

The random reassignment is done to prevent biased change of the curvature.

BINDER DISTRIBUTION

In real life, the process of adding binder to the material is affected by gravity and the viscosity of the binder, leading to inhomogeneous distributions. This effect can be modeled by defining a distribution of the binder under the **Binder Distribution** tab.

The default distribution is **Homogenous**, but it can be changed to a **Density Distribution in Z-Direction** to allow the modeling of inhomogeneity.

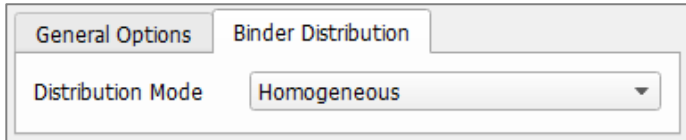

General Options | Binder Distribution

Distribution Mode: **Homogeneous**

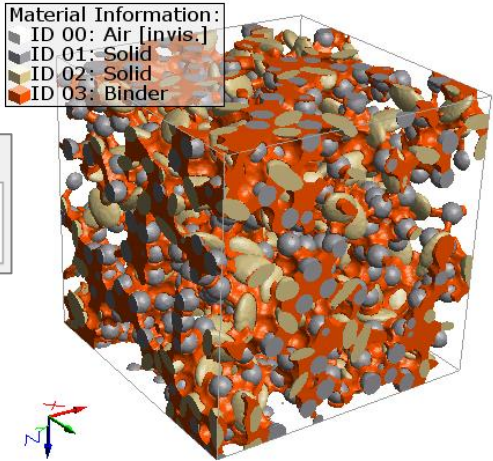

Material Information:
 ID 00: Air [invis.]
 ID 01: Solid
 ID 02: Solid
 ID 03: Binder

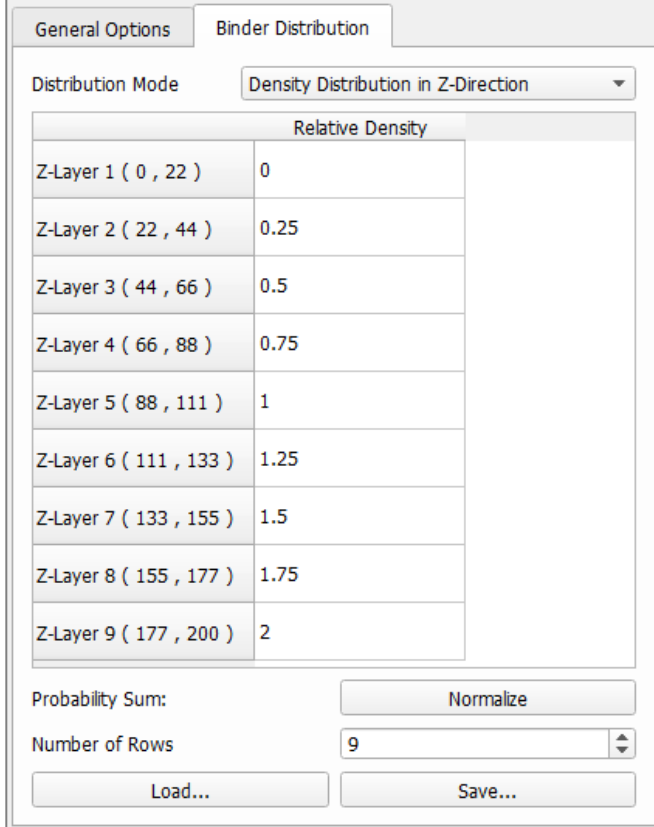

General Options | Binder Distribution

Distribution Mode: **Density Distribution in Z-Direction**

Relative Density	
Z-Layer 1 (0 , 22)	0
Z-Layer 2 (22 , 44)	0.25
Z-Layer 3 (44 , 66)	0.5
Z-Layer 4 (66 , 88)	0.75
Z-Layer 5 (88 , 111)	1
Z-Layer 6 (111 , 133)	1.25
Z-Layer 7 (133 , 155)	1.5
Z-Layer 8 (155 , 177)	1.75
Z-Layer 9 (177 , 200)	2

Probability Sum:

Number of Rows:

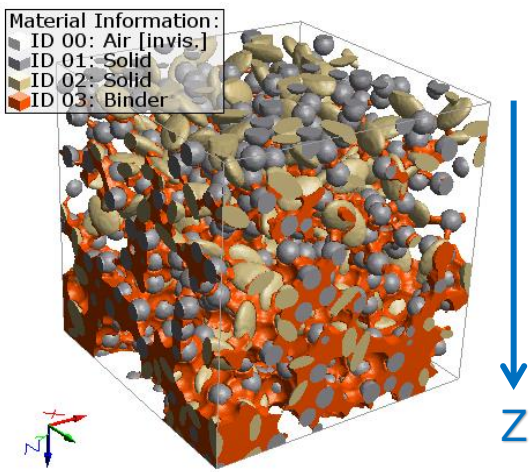

Material Information:
 ID 00: Air [invis.]
 ID 01: Solid
 ID 02: Solid
 ID 03: Binder

Z

The **Number of Rows** defines the number of segments in Z-direction. To change the number of segments, change the **Number of Rows** to the number of segments desired.

The algorithm tries to reach the desired binder amount for each segment. In each of them, the binder is generated separately according to the rules defined in the **General Options** Tab. The **Added Solid Volume Percentage / (%)** is scaled to the normalized density distribution.

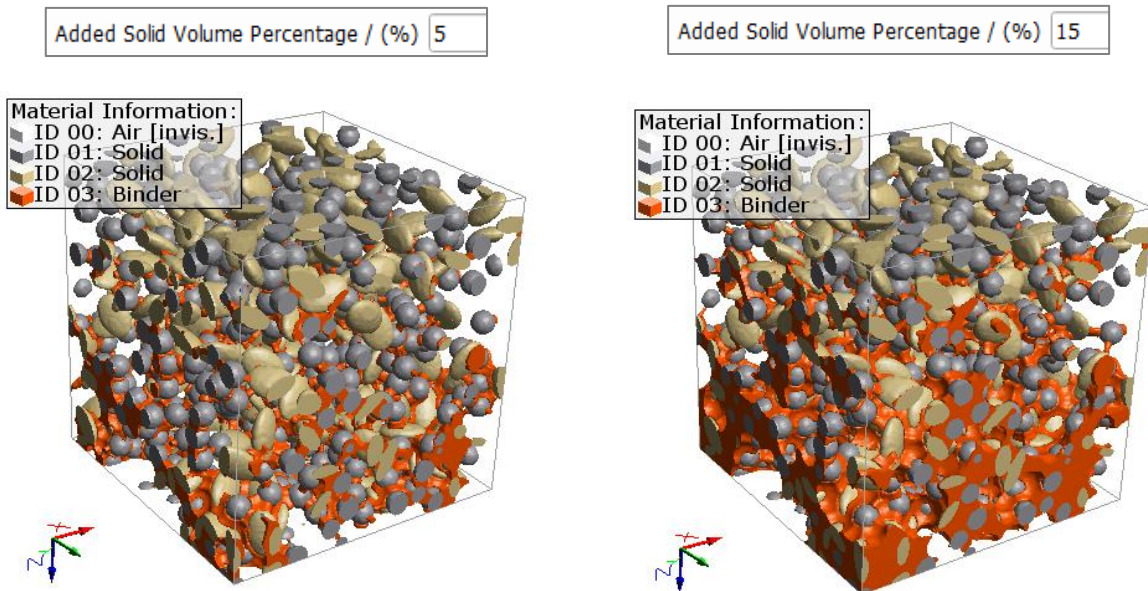

The **Binder Distribution** can be entered in form of a ratio in the **Relative Density** table.

In the images below three different segments are discernible with a binder distribution according to the relative values given in the table.

General Options Binder Distribution

Distribution Mode Density Distribution in Z-Direction

Relative Density	
Z-Layer 1 (0 , 66)	0.8
Z-Layer 2 (66 , 133)	0
Z-Layer 3 (133 , 200)	0.2

Probability Sum: 1

Number of Rows 3

General Options Binder Distribution

Distribution Mode Density Distribution in Z-Direction

Relative Density	
Z-Layer 1 (0 , 66)	1
Z-Layer 2 (66 , 133)	3
Z-Layer 3 (133 , 200)	6

Probability Sum: 10

Number of Rows 3

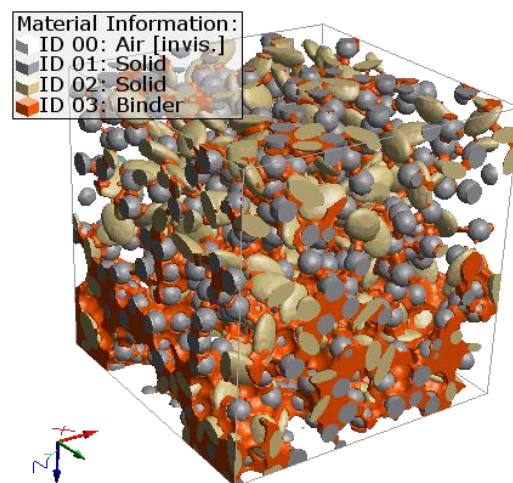
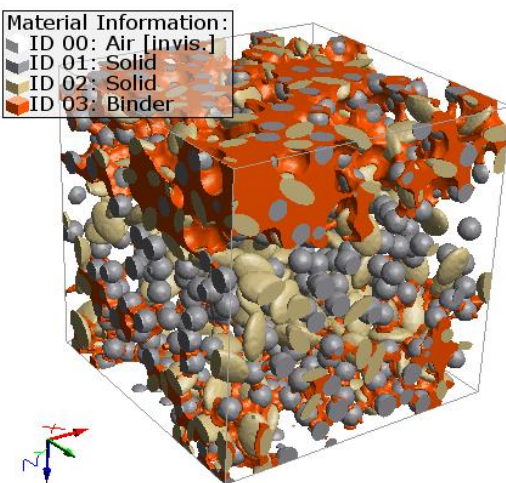

Clicking the **Normalize Button** ensures the Relative Density sums up to 1.

With the Buttons **Load...** and **Save...** the Distribution can be loaded/saved as text file which can be opened with other software as e.g. Microsoft Excel.

The parameters entered in the **Add Binder** dialog can be saved into *.gps (GeoDict Project Settings) files and/or loaded from them. Remember to restore and reset your (or GeoDict's) default values through the icons at the bottom of the dialog when needed and/or before every GrainGeo-**Add Binder** run. Resting the mouse pointer over an icon prompts a ToolTip shows the icon's function.



GRAIN GEOAPPS

When **Grain GeoApps** is selected in the **GrainGeo** section, predefined structures can be chosen from the pull-down menu in the **Grain GeoApps** panel: Al₂O₃-ceramic, Cordierite-Ceramic, Martensite, Metal-Matrix Composite, PZT-Ceramic, SiC-Ceramic, Water Membrane, and Piling of Complex Objects.

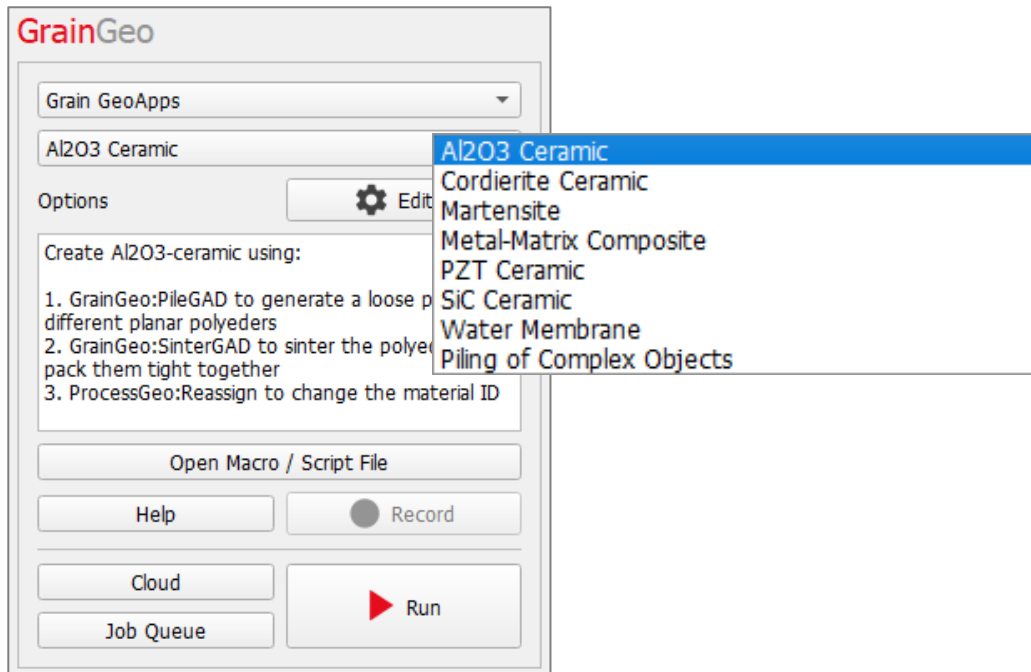

ADD GRAIN GEOAPPS STRUCTURES

During the creation of predefined materials, the corresponding **GeoDict** macros are called and executed. These macros can be accessed through the **Open Macro-File** button; alternatively, they are available in the **GrainGeo** folder in the **GeoDict** installation folder. They can be opened with a text editor to check or edit the syntax of the generation steps. To learn how to add GeoApps, refer to the [GeoApp](#) handbook.



EDIT AND GENERATE GRAIN GEOAPP STRUCTURES

By clicking the **Options' Edit...** button, the corresponding parameter dialog opens and the parameters defining the representative granular structures are displayed and can be modified.

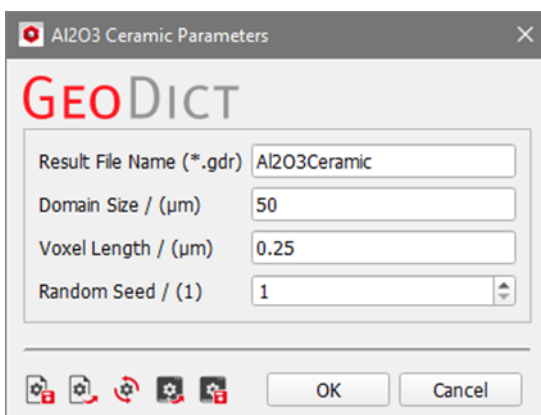

Click **OK** closes the dialog. Then, click **Run** to create the structure.

GRAIN GEOAPP GALLERY

All GeoApps can be edited through the **Options' Edit...** button. The parameters for the apps are shown in their respective dialog. Click **Run** to create the structure with the chosen settings.

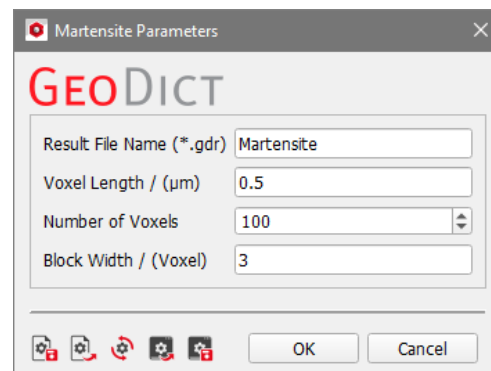
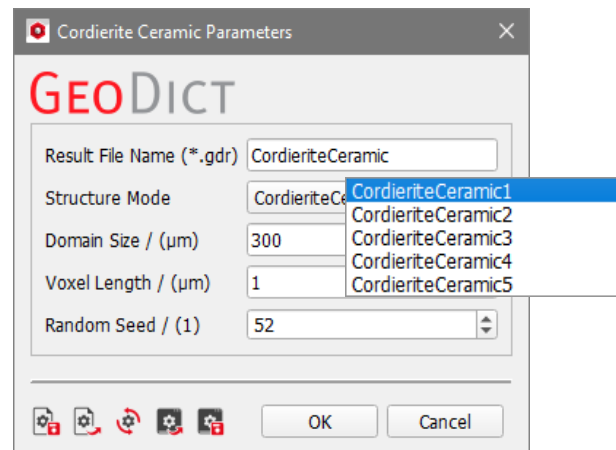
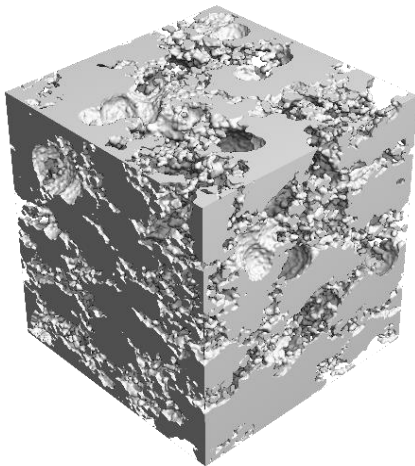
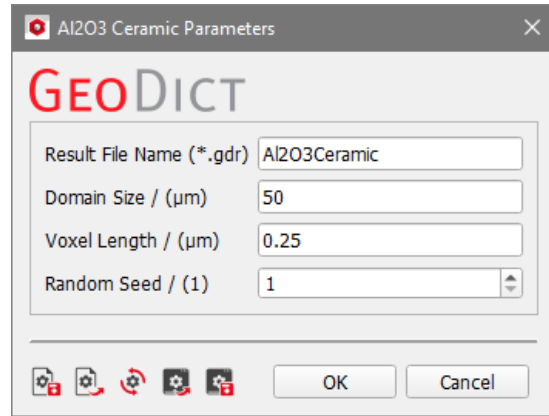

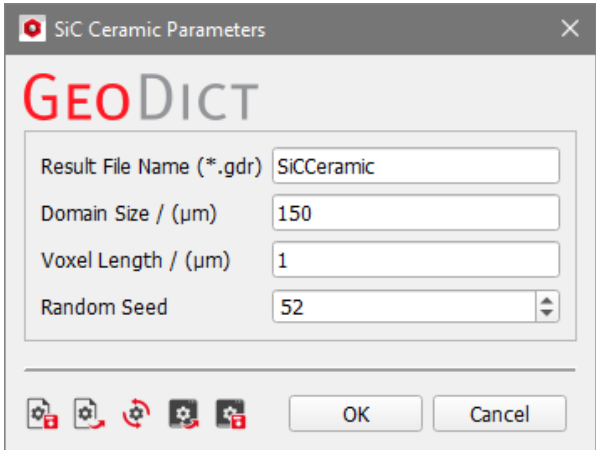
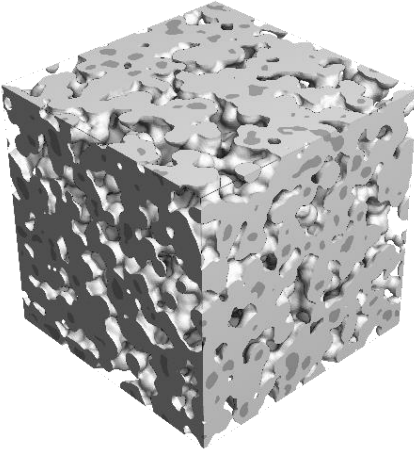
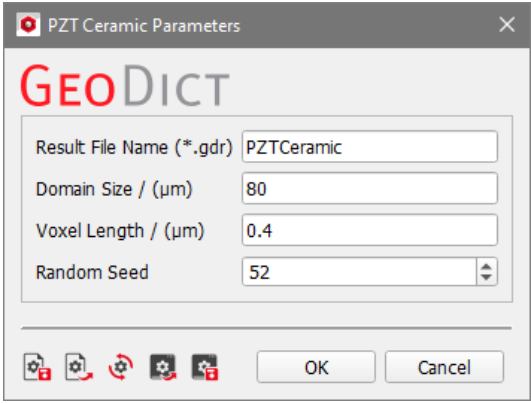
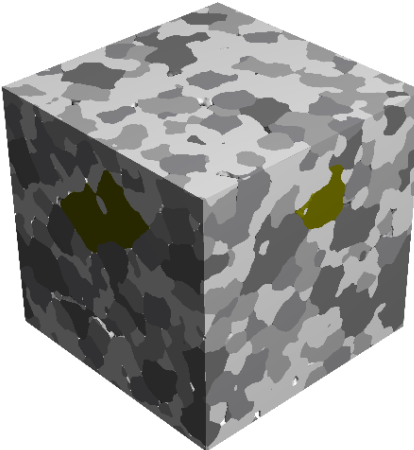
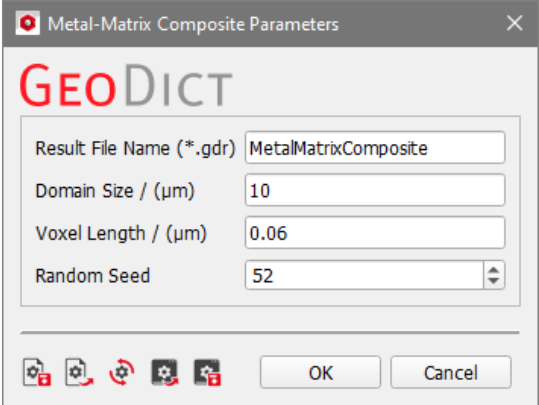
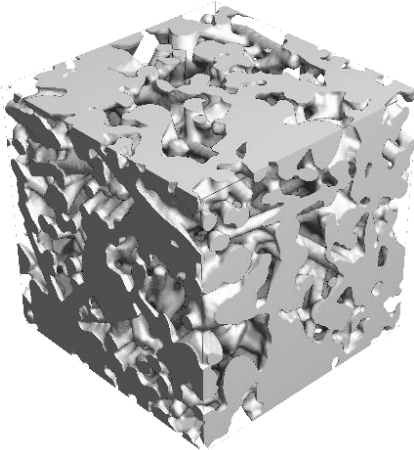

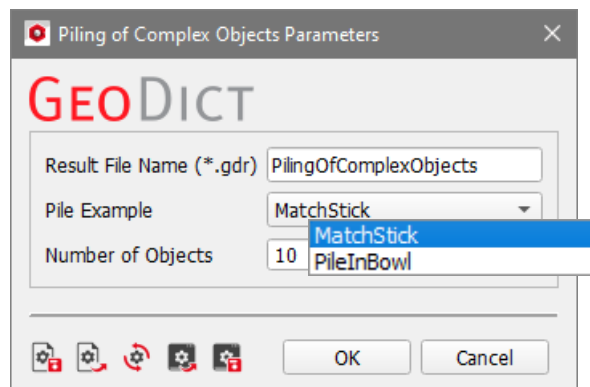
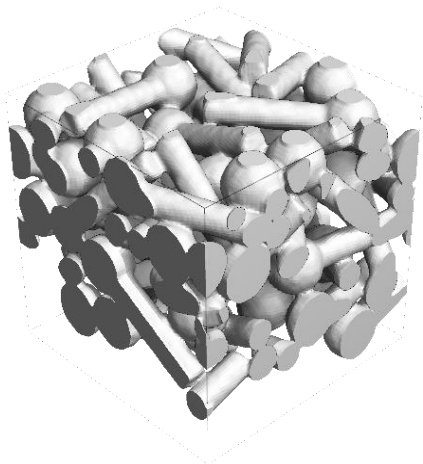
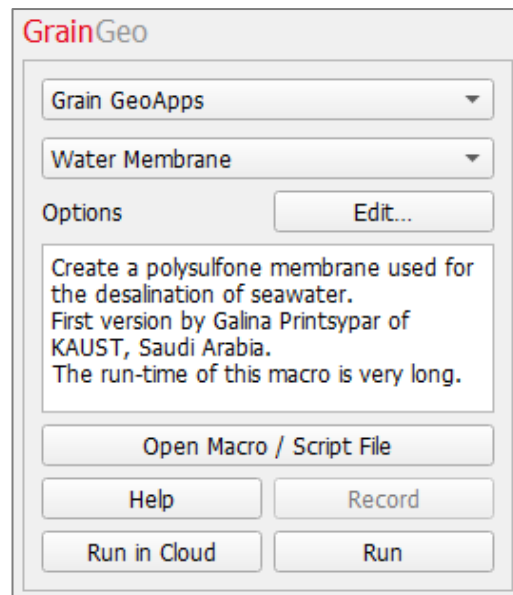
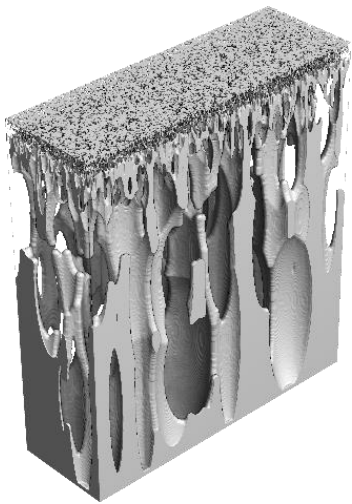

CREATE GAUSSIAN RANDOM FIELDS

GAUSSIAN RANDOM FIELD GENERATOR

A Gaussian random field describes a volume field with correlated noise. This means the probability of similarity between two values decreases exponentially with their distance. In the Gaussian Random Field Generator in **GeoDict**, several Gauss functions can be combined to define a random field.

In the image on the right, a scalar gaussian random field in a jet colour gradient is shown. The corresponding Gaussian function has a standard deviation of 3.

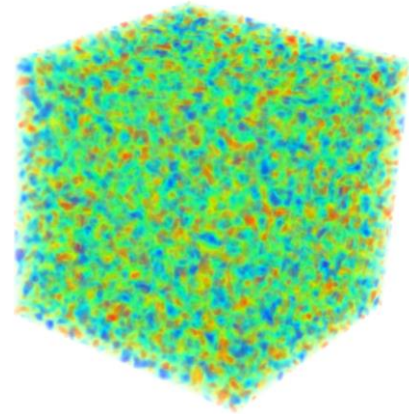

Gaussian Random field then can be segmented to a structure:

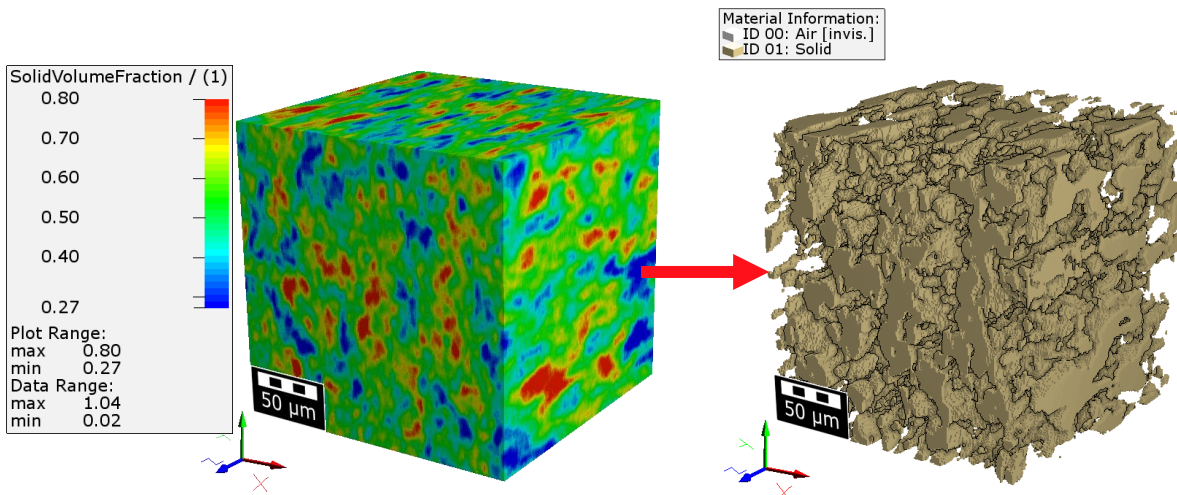

In the following example observe different forms of noise.

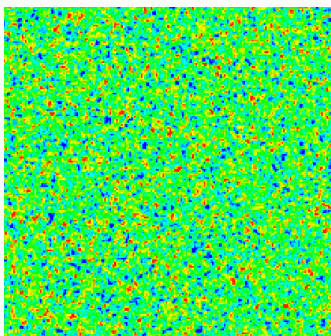

Uncorrelated noise, all values are independent

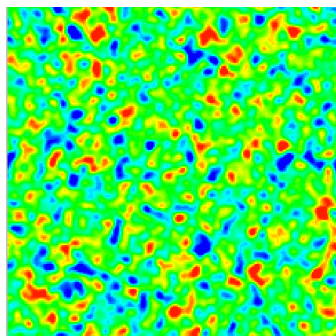

Noise following a spatial correlation. The values are correlated with their spatial neighbourhood.

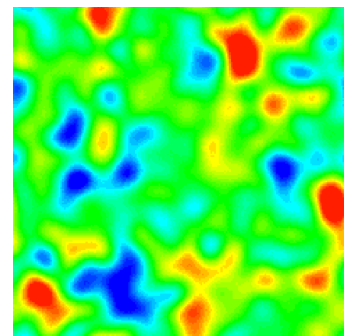

Noise following a spatial correlation with a large correlation length.

The spatial correlation can be specified with an autocorrelation graph. For each distance between two voxels the probability of similarity, also called covariance, is described.

In the **Gaussian Random Field Generator**, the user may define several autocorrelation functions to generate a custom random field.

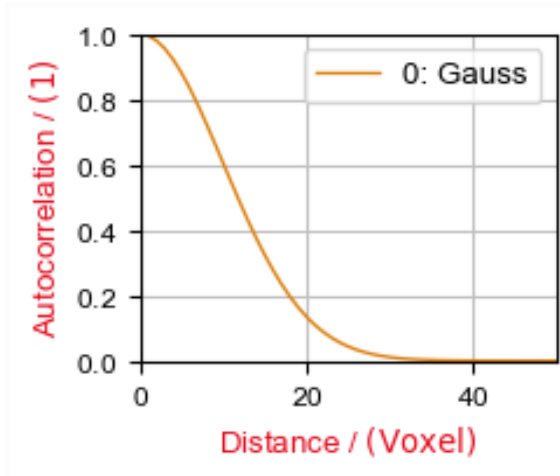

To open the **Gaussian Random Field Generator**, right-click on **Volume Field** in the **Project Status** section in the left-hand side of **GeoDict** and select **Create Gaussian Random Field**.

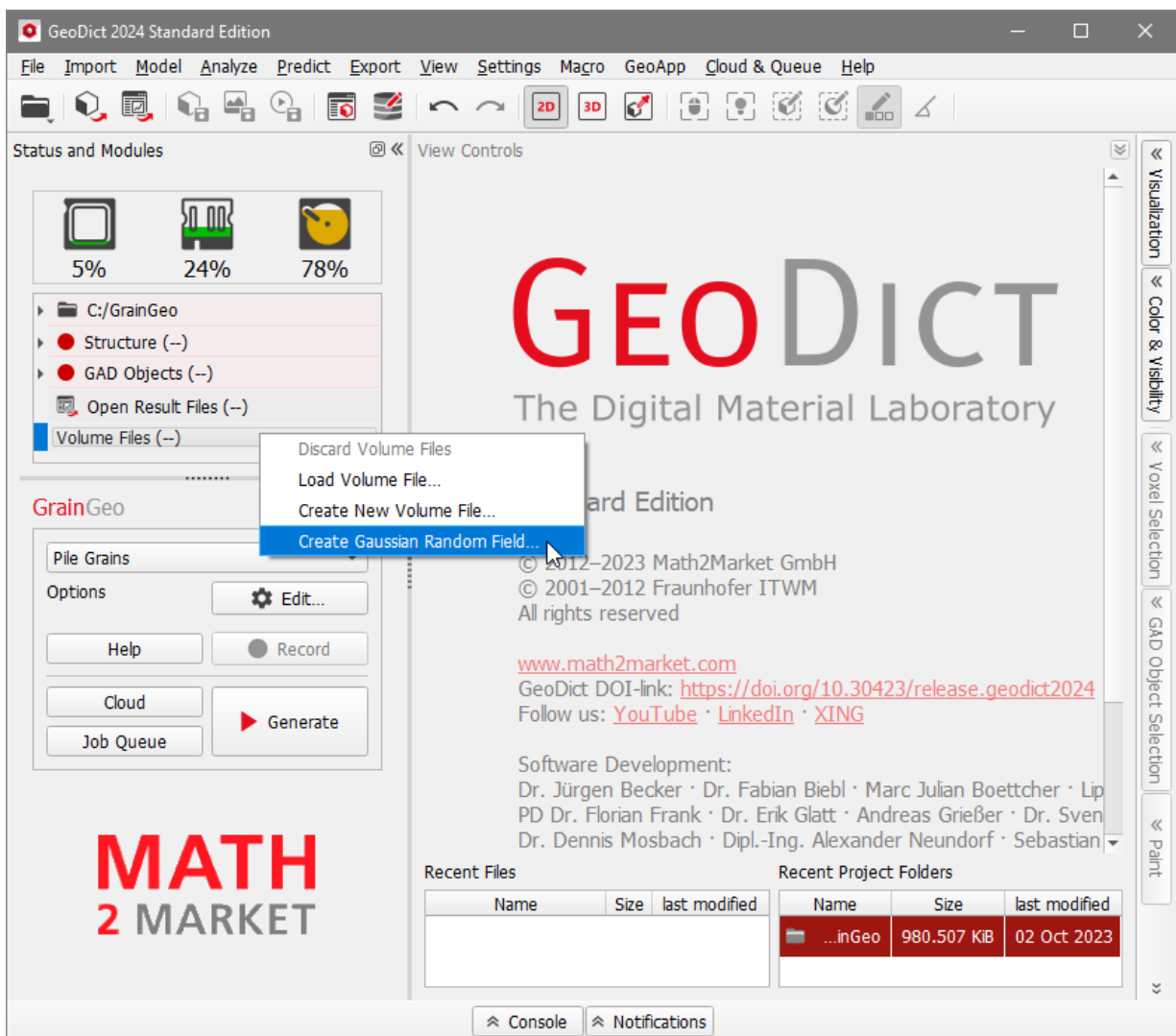

At the top left of the **Gaussian Random Field Generator** dialog, the name for the file containing the generation results can be entered in the **Result File Name (*.gdr)** box. The default name can be kept, or a new name can be chosen, fitting the current project.

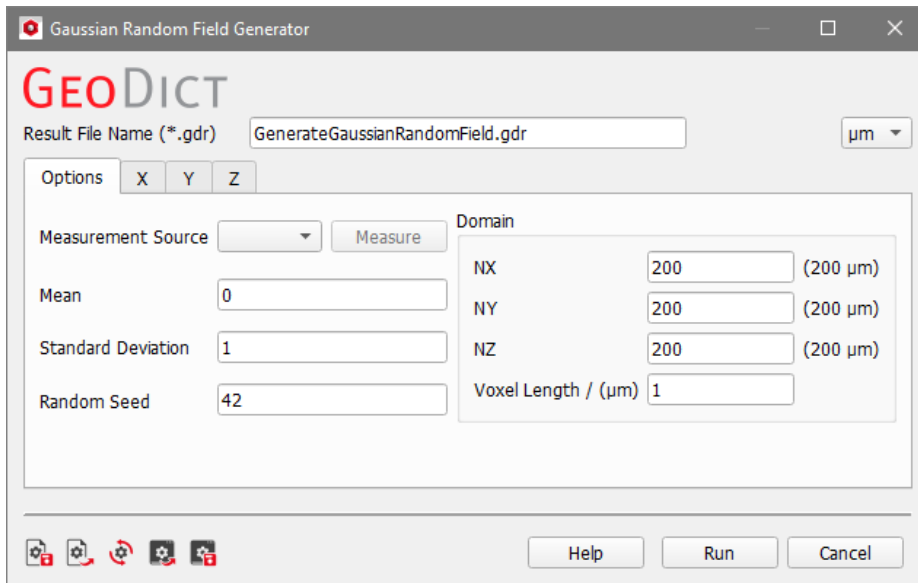

The available units (**m**, **mm**, **µm**, and **nm**) are selectable from the pull-down menu at the top right of the **Gaussian Random Field Generator** dialog. When the units are changed, the entered values are adjusted automatically.

The **Gaussian Random Field Generator** dialog is organized using four tabs:

- **Options:** Determine general properties of the resulting structure, such as size and resolution.
- **X, Y, Z:** Define the autocorrelation parameters for the three axial directions.

The result files are saved in the chosen project folder (**File** → **Choose Project Folder**, in the Menu bar). If a **GeoDict** results file (*.gdr) with the given name already exists in the project folder, a warning message is shown at the start of the creation process. The user can either decide to back up the old file, to overwrite it, or to cancel and choose a new file name.

OPTIONS

The geometric properties of the desired random field are accessible under the **Options** tab. The parameters are grouped in the parameters defining the general randomness and the **Domain** parameters.

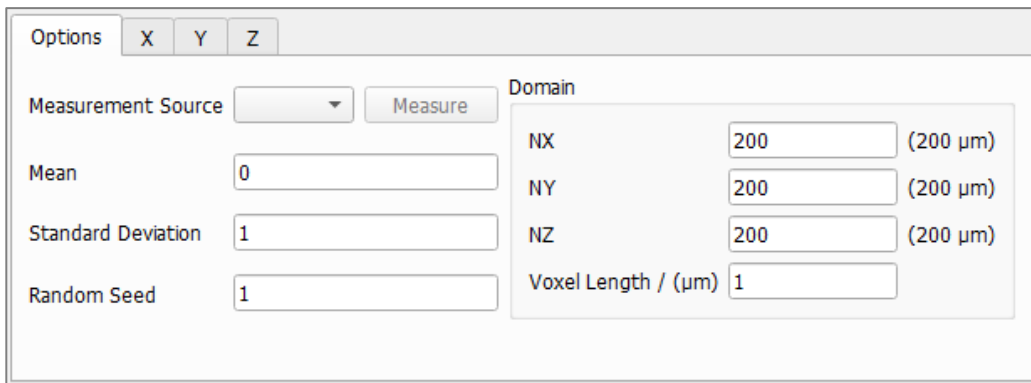

RANDOMNESS PARAMETERS

If a volume field is loaded, a **Measurement Source** can be selected. This is useful, for example, if a scan with a random field-like structure should be reproduced with a different realization of the same statistical properties. Clicking **Measure** then computes the autocorrelation for the volume field values and adds the corresponding graph in the **X, Y** and **Z** tabs as **Measured Covariance**. In the **Options** tab the **Mean** value and the **Standard Deviation** of the selected field are also entered automatically.

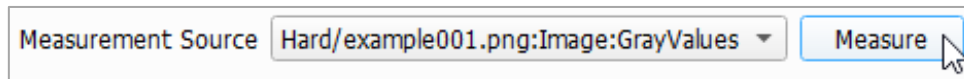

If the volume field is not given in the right data type and thus does not show up in the pull-down menu, it can be transformed. Therefore, right-click on it in the Project Status and select **Math Operation**.

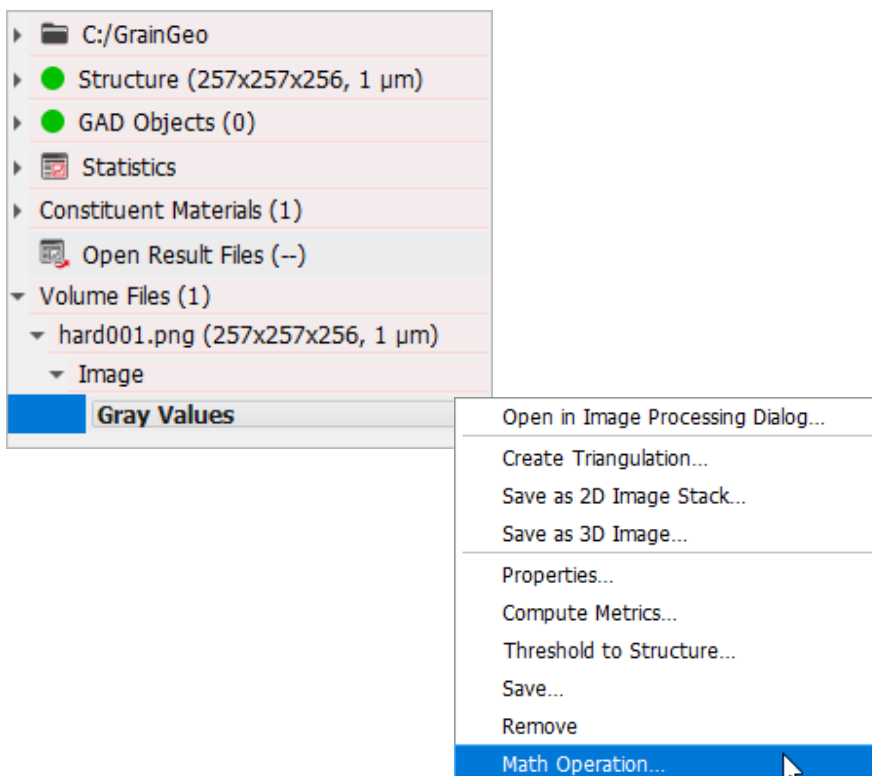

In the **Math Operation** dialog select **Convert Data Type** from the first and **Float Single-Precision** from the second pull-down menu.

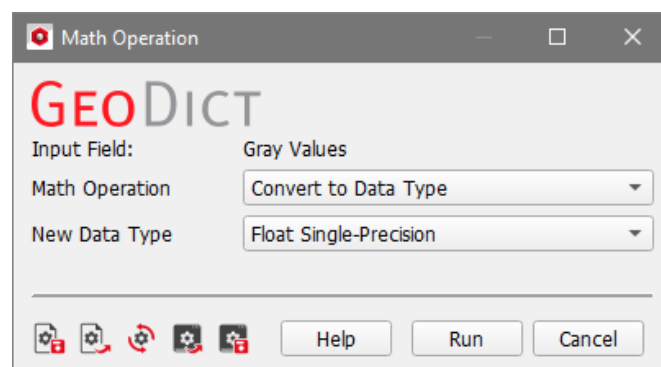

To generate a new custom random field, enter the desired **Mean** value and **Standard Deviation** manually. These values correspond to the generated random field and define the value range in it.

Mean	<input type="text" value="0"/>
Standard Deviation	<input type="text" value="1"/>

In the following observe how the data range changes for different mean values and standard deviations while all other parameters are kept the same.

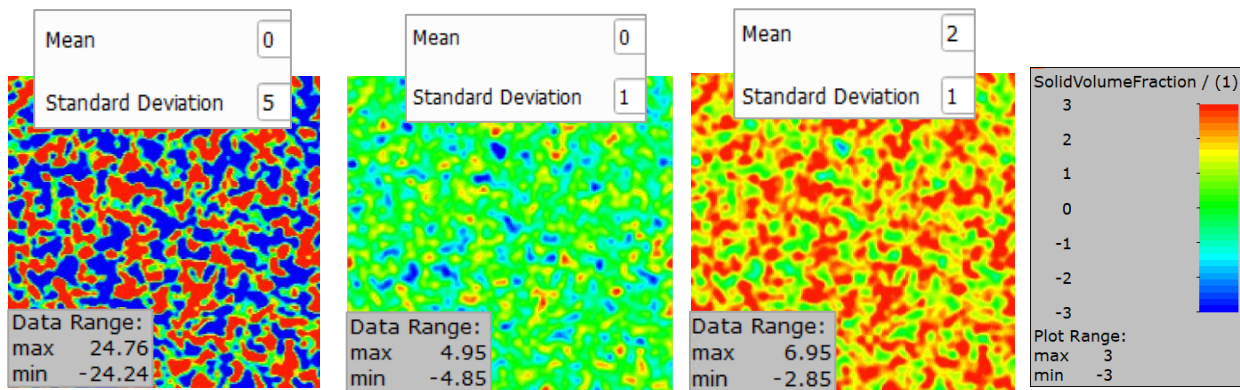

Random Seed initializes the random number generator behind the field generator. Changing its value produces different sequences of random numbers and hence, different realizations of the specified random field. If all settings are equal, generating with the same **Random Seed** value produces the identical random field. **Random Seed** must be a non-negative integer number.

DOMAIN PARAMETERS

The **Domain** panel contains the parameters defining the structure size (**NX**, **NY**, and **NZ**) in combination with the resolution (**Voxel Length**).

NX, **NY**, and **NZ** are the number (N) of voxels in X, Y and Z directions.

The **Voxel Length** is the size of one voxel in the chosen units. Varying the values for NX, NY, and NZ has the effect of changing the size of the structure in the given direction.

Low values for **Voxel Length** in combination with high values for **NX**, **NY** and **NZ** increase the resolution, but also increase computational time. After setting the values of **NX**, **NY**, and **NZ**, and **Voxel Length**, the physical structure size is automatically displayed in the chosen units. If a scan should be statistically reproduced, use the same voxel length here.

X, Y, Z AUTOCORRELATION SETTINGS

In these tabs the covariances for the corresponding directions are defined.

Define several autocorrelation functions in the left panel and view a preview of the current **Generator Input** function on the right. The generator input is the sum of the defined elements in the **Parameters** panel and defines the resulting covariance for the Gaussian random field.

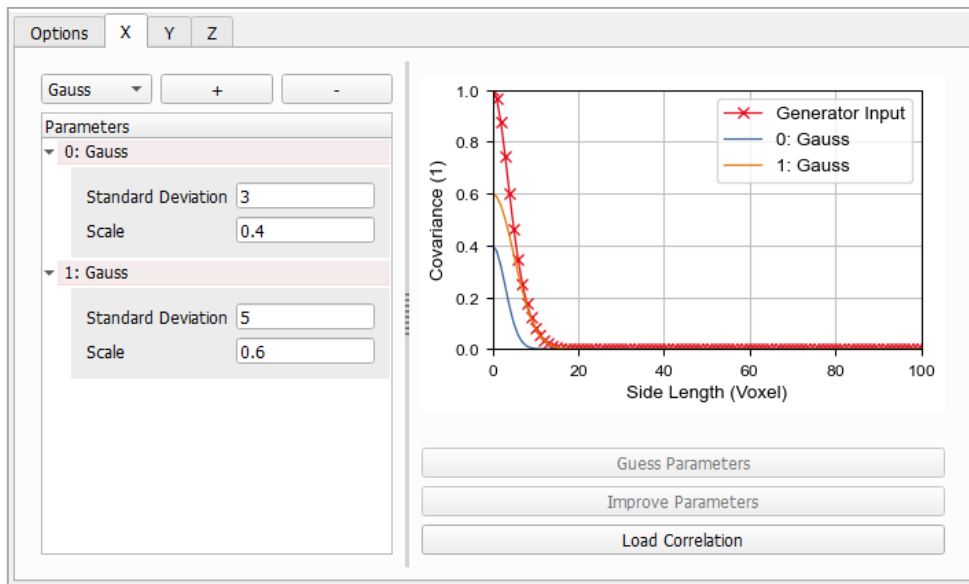

The **Side Length** defines the length of correlated areas in voxel. The **Covariance** value displays the relative amount of areas with the given side length.

Either **Linear** or **Gauss** functions can be added. Select them from the pull-down menu in the upper left corner and click . To remove a function, select it in the **Parameters** panel and click .

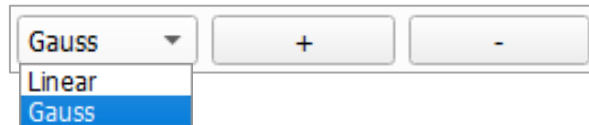

The corresponding graphs are shown on the right with the same name and update automatically whenever a parameter is changed.

The **Generator Input** then is the normalized sum of all the functions and defines the autocorrelation of the generated Gaussian random field. It is also possible to combine Gauss and Linear functions.

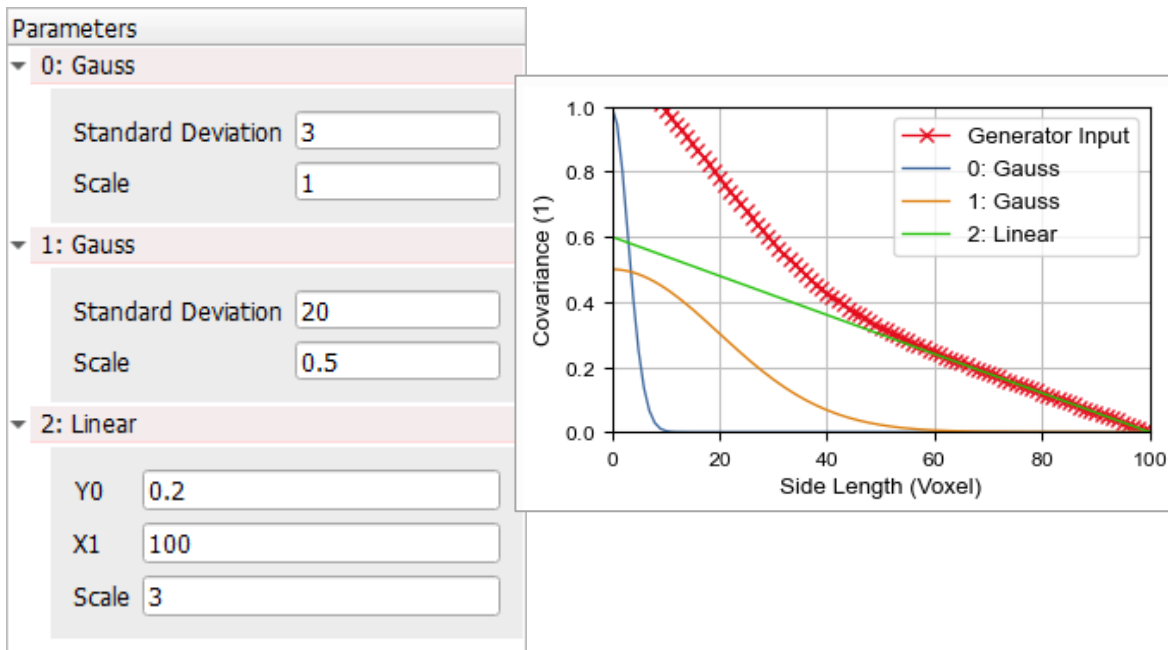

GAUSS FUNCTION PARAMETERS

In the **Parameters** panel for **Gauss** functions, define **Standard Deviation** and **Scale**.

Standard Deviation controls the range for **Side Length**. Note, that the standard deviation here directly refers to the corresponding Gauss function, while the standard deviation in the **Options** tab defines the value range in the generated Gaussian Random Field.

Scale controls the range for the **Covariance**, being a factor multiplied to the Gauss function.

In the following example, observe the impact of scale and standard deviation on the graphs. The generator input visualization was turned off by right-clicking in the plot and deselecting **Generator Input**

To learn more about how to edit plots in GeoDict refer to the [Result Viewer](#) handbook of this User Guide.

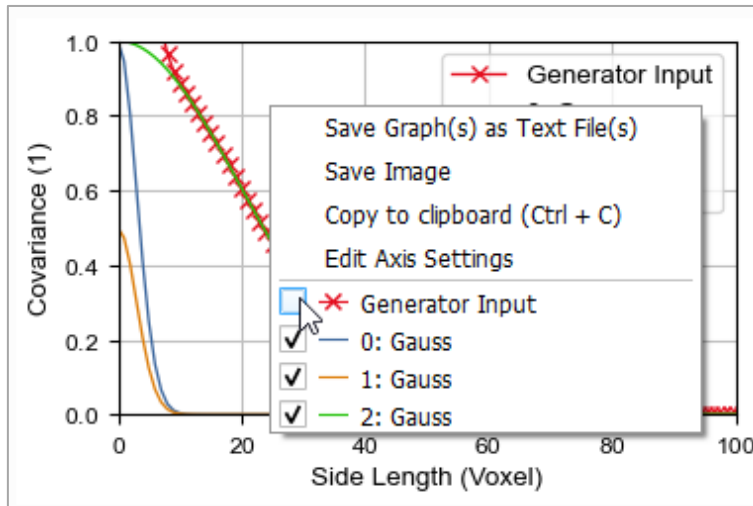

Parameters

- 0: Gauss
 - Standard Deviation: 3
 - Scale: 1
- 1: Gauss
 - Standard Deviation: 3
 - Scale: 0.5
- 2: Gauss
 - Standard Deviation: 20
 - Scale: 1

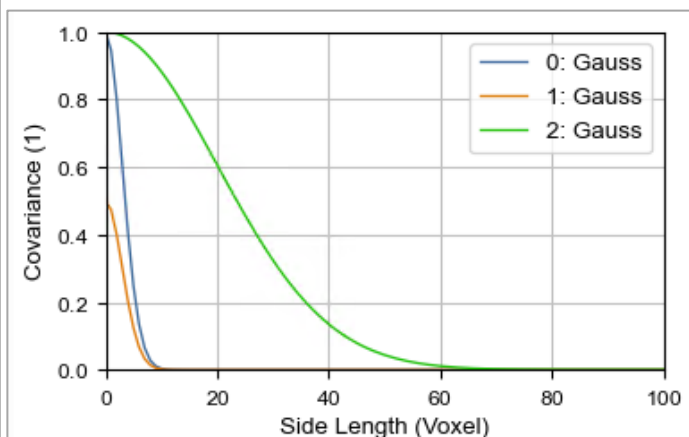

LINEAR FUNCTION SETTINGS

For **Linear** functions define the intercept of the linear function with the Y-axis (**Y0**) and the X-axis (**X0**) and multiply this function with the factor given for **Scale**.

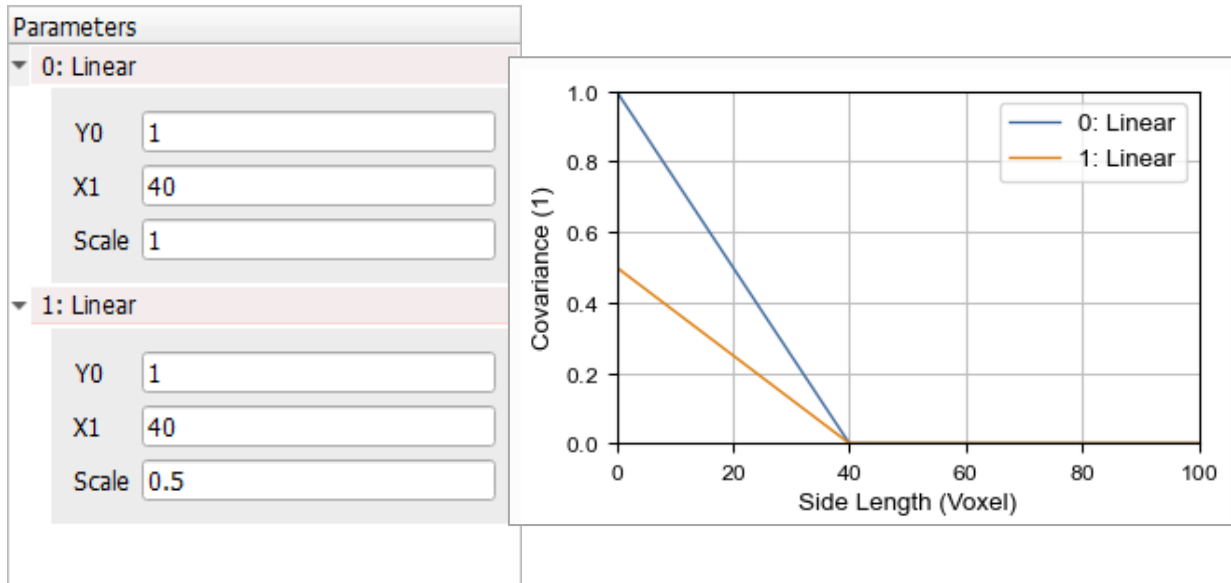

LOAD CORRELATION, GUESS PARAMETERS, IMPROVE PARAMETERS

While loading the autocorrelation values in the **Options** tab as described on page 150 is usually the easiest possibility, autocorrelations can also be loaded from GeoDict result files generated with **Compute Metrics**, available from the **Project Status** by right-clicking on the volume field to analyze.

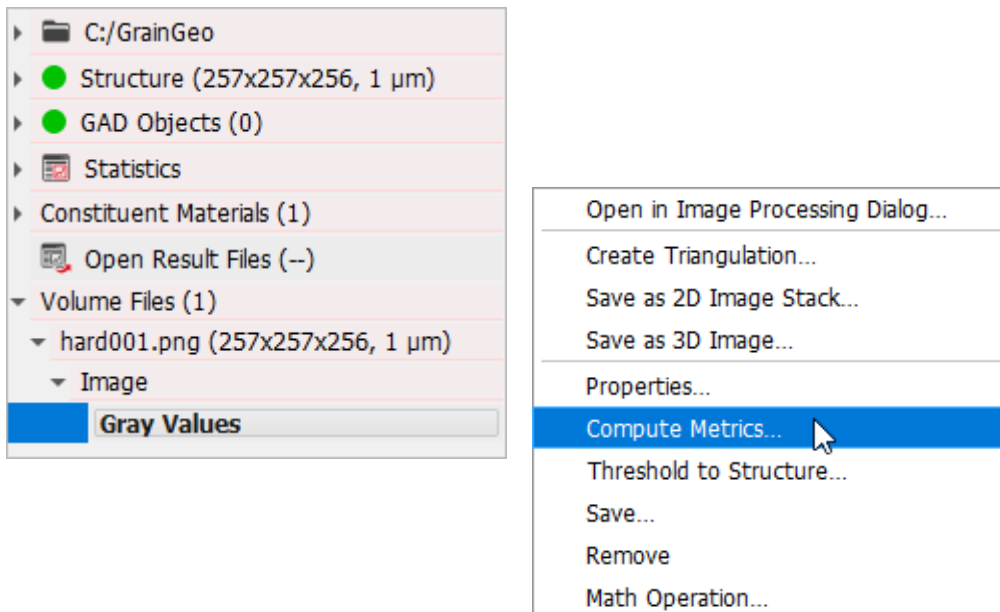

In the **Compute Metrics** dialog select **Minimum, Maximum, Mean Value, Standard Deviation and Variance** and **Autocorrelation** and define the parameters as needed.

For example, if the autocorrelation in the current field is different for the three directions, compute the metrics for each direction. Therefore, for **Direction** select **X-, Y- or Z-Direction** instead of **Isotropic**.

Clicking **Run** computes the standard deviation, mean value and autocorrelation function for the chosen volume field.

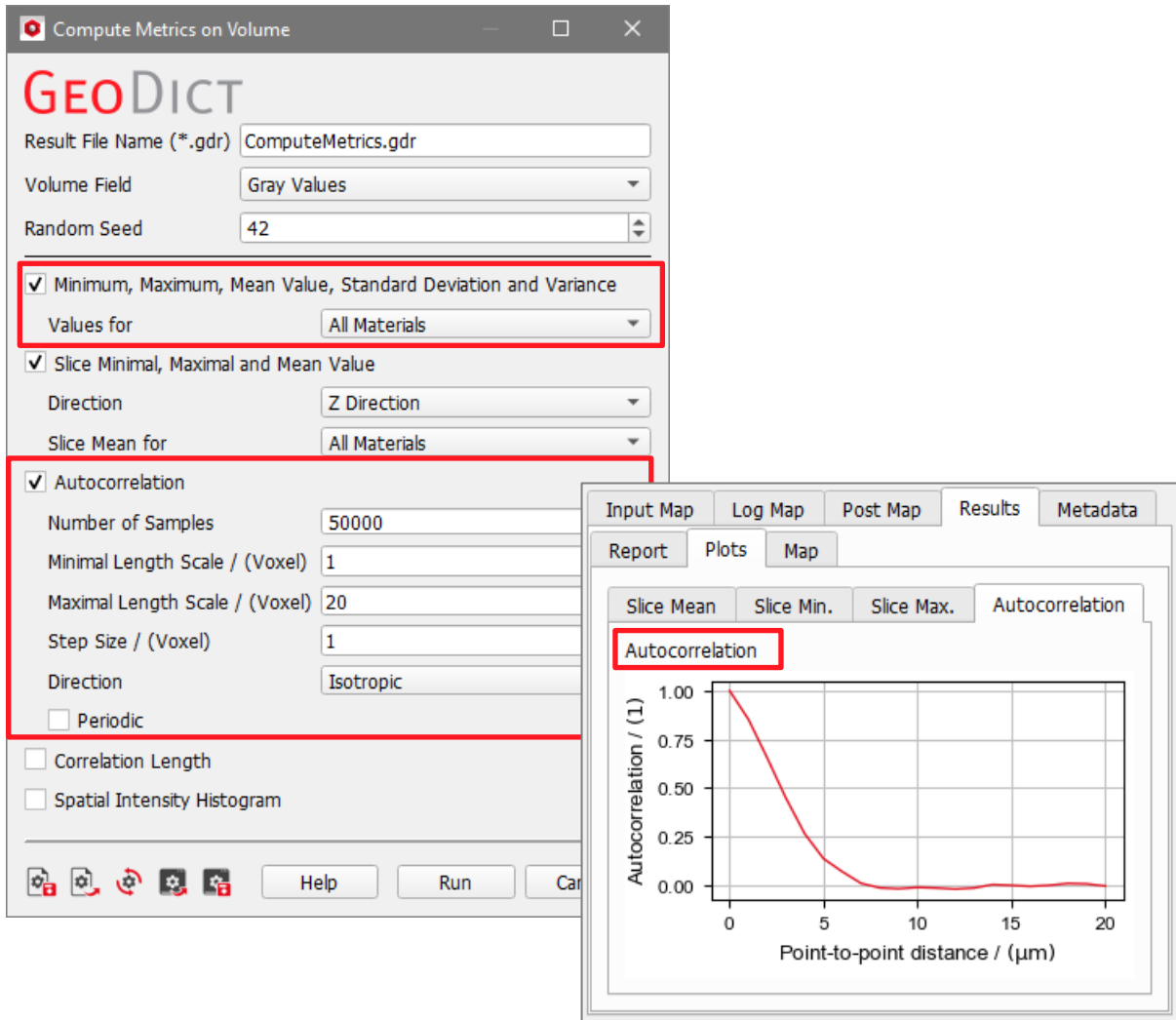

In the **Gaussian Random Field Generator** enter the **Standard Deviation** and **Mean** manually in the **Options** tab as given in the **Compute Metrics** result file.

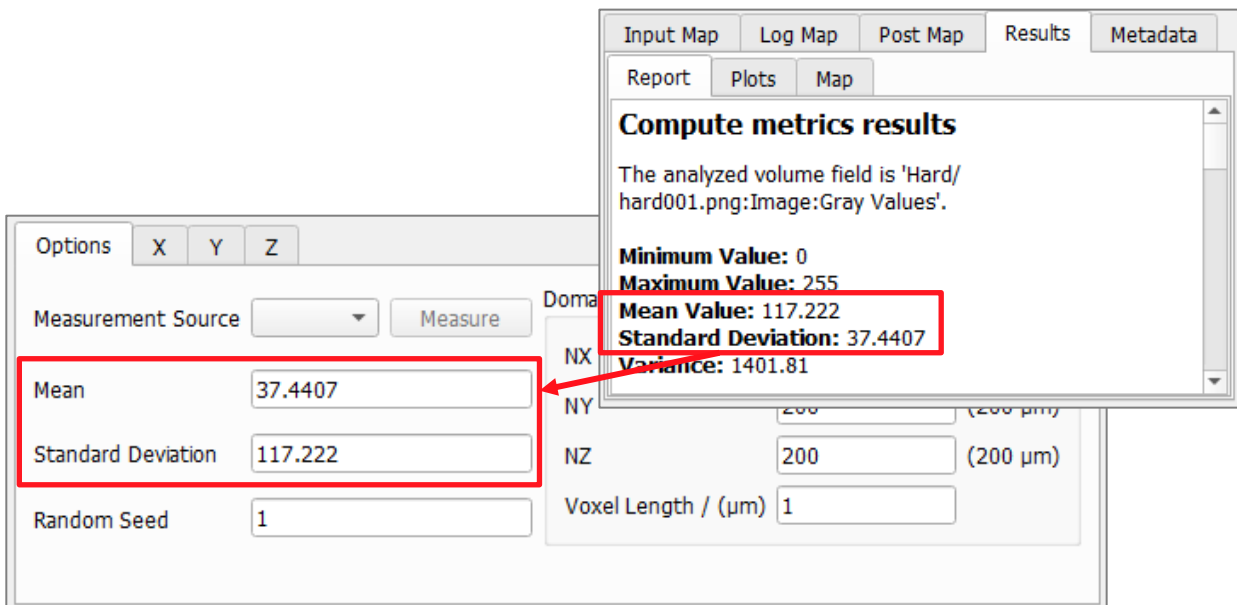

Then, move to each of the **X**, **Y** and **Z** tabs and load the computed autocorrelations. Therefore, click **Load Correlation** and browse for the **Compute Metrics** result.

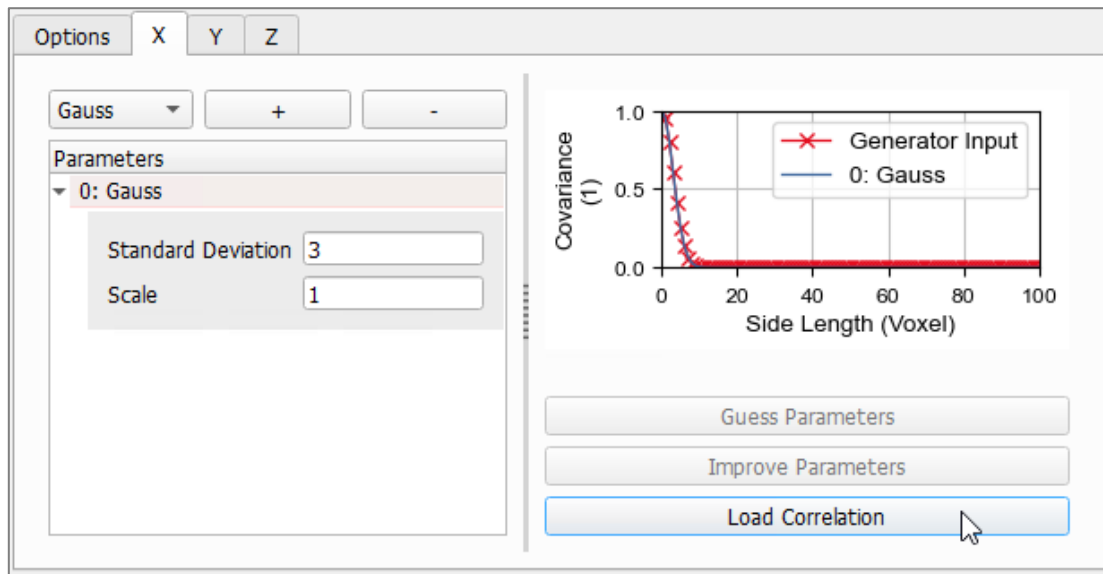

If an autocorrelation was loaded either from the current volume field or from a metrics result, in the plot a graph for the **Measured Covariance** is added and the buttons **Guess Parameters** and **Improve Parameters** become available. Additionally, below the plot the **Error** between the measured covariance and the current generator input is displayed. It is computed as the sum of squared deviations for all data points in the curve.

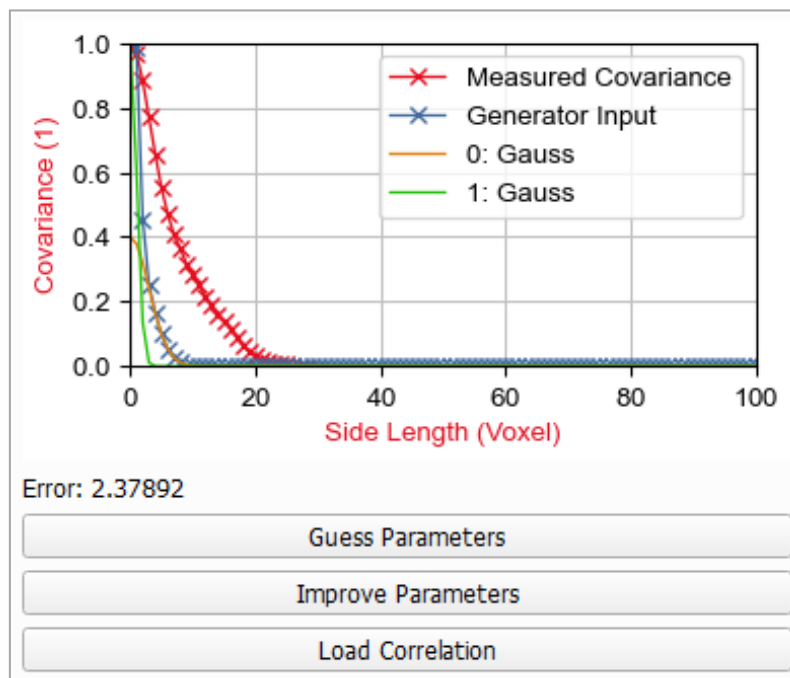

The number and type of functions needed to fit the measured covariance must be defined by the user. After adding the desired number of Gauss or Linear functions, clicking **Guess Parameters** tries different parameters to fit the measured covariance. Automatically, the first best guess of the algorithm is entered for the parameters.

It can be necessary to click **Improve Parameters** several times, if the **Generator Input** does not fit the **Measured Covariance** with the desired accuracy.

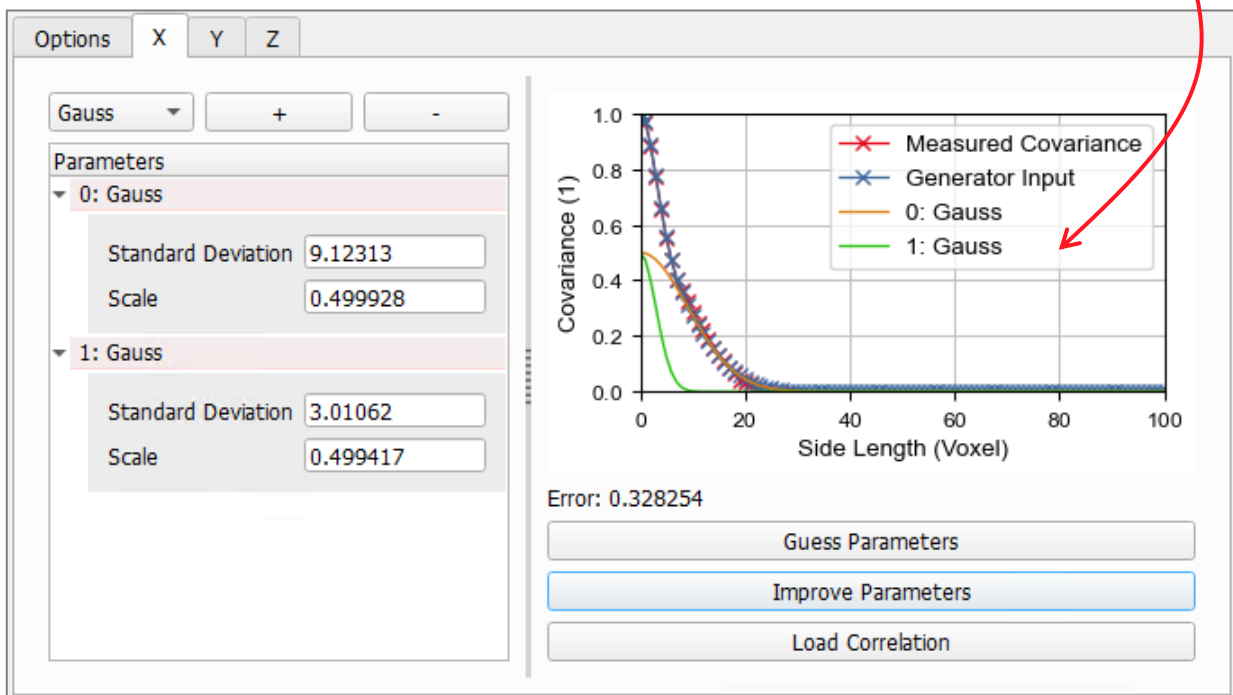
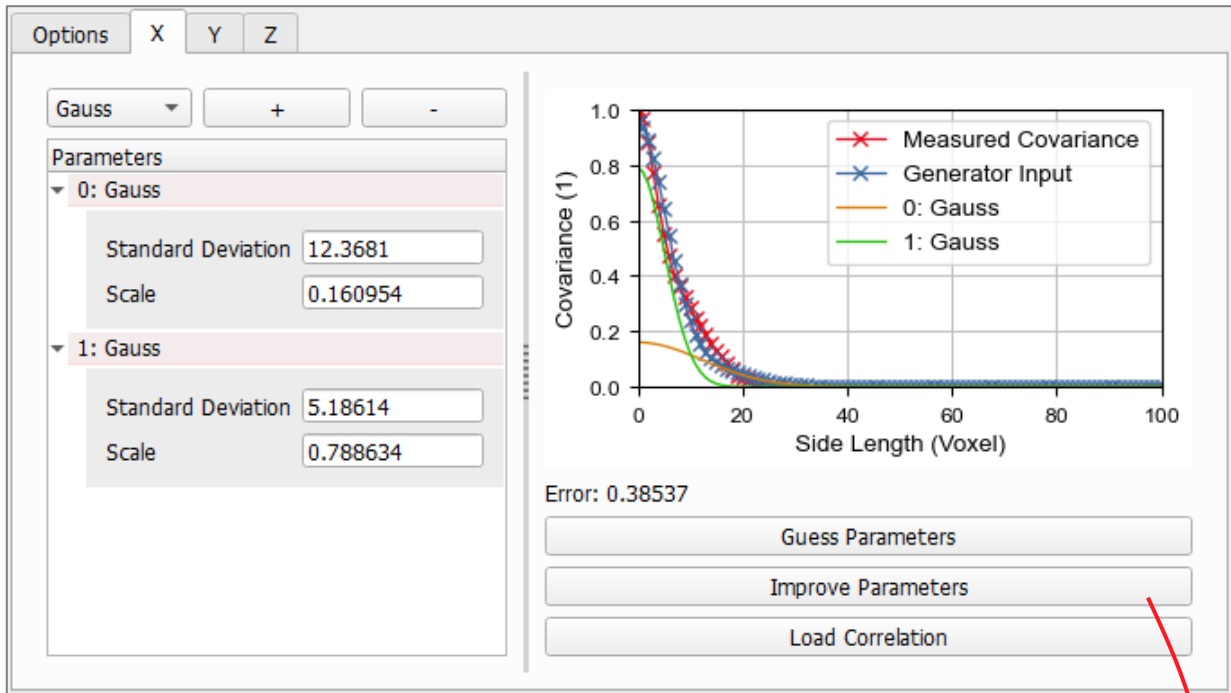

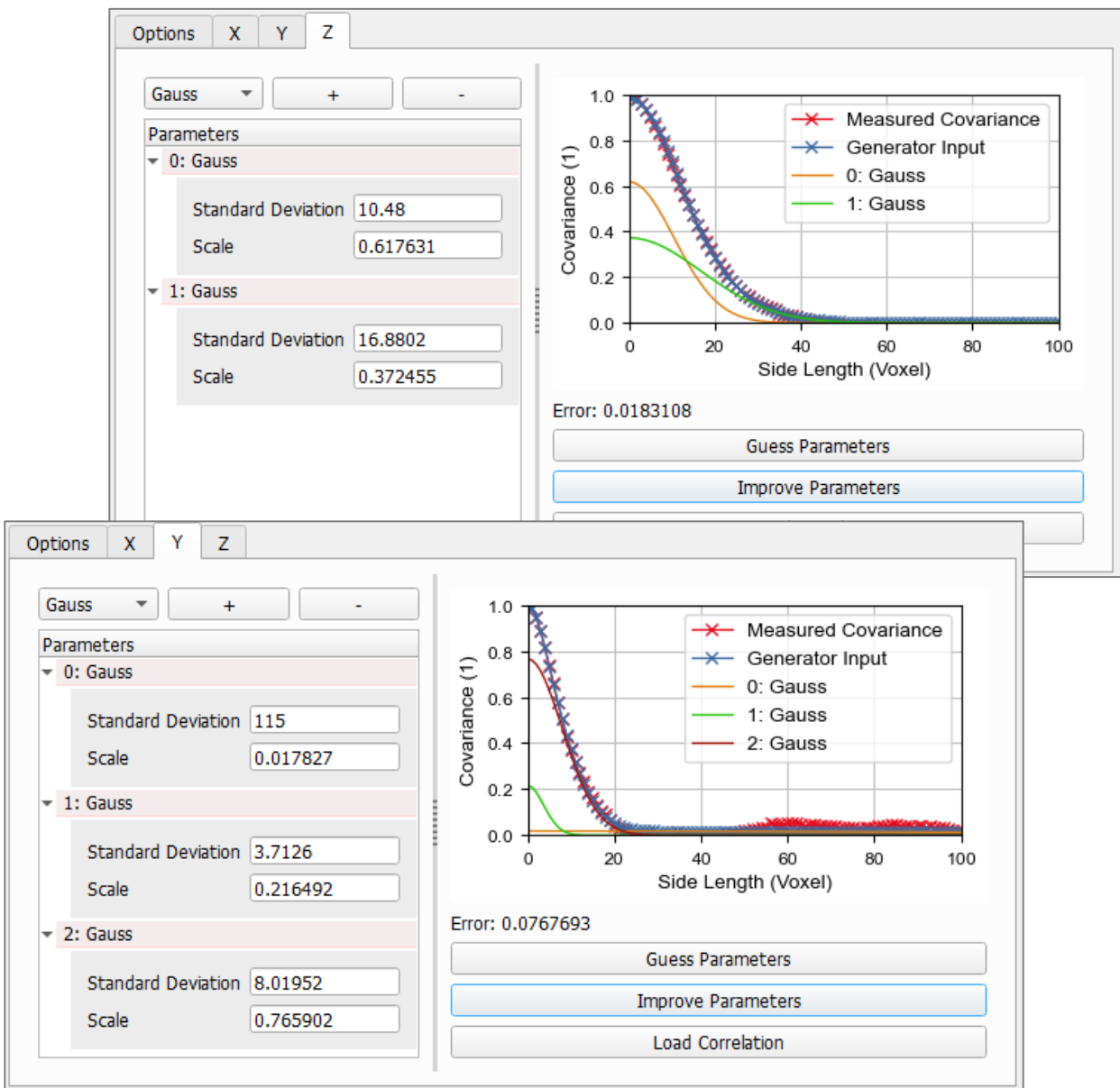

After setting all autocorrelation functions as desired for all three directions, clicking **Run** generates the Gaussian random field.

If the domain parameters are not large enough to represent the given covariances, a warning dialog appears. Decide if the generation should proceed or if it should be aborted. Changing the domain size accordingly improves the accuracy.

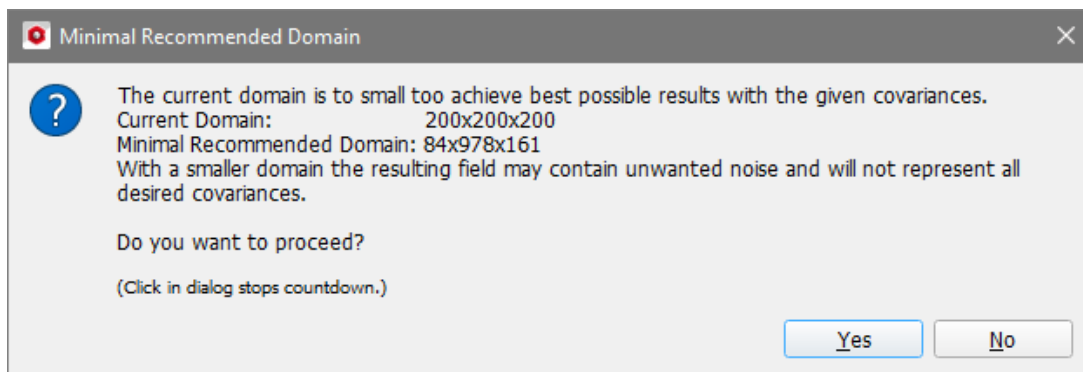

RESULTS FOR GAUSSIAN RANDOM FIELDS

Generating a Gaussian random field produces a **GeoDict** result file (*.gdr) and a result folder with the same name. Both are saved in the chosen project folder (**File** → **Choose Project Folder...** in the menu bar).

The **GeoDict Result Viewer** opens for the result file and in the **Results – Report** subtab find the dimensions of the generated field.

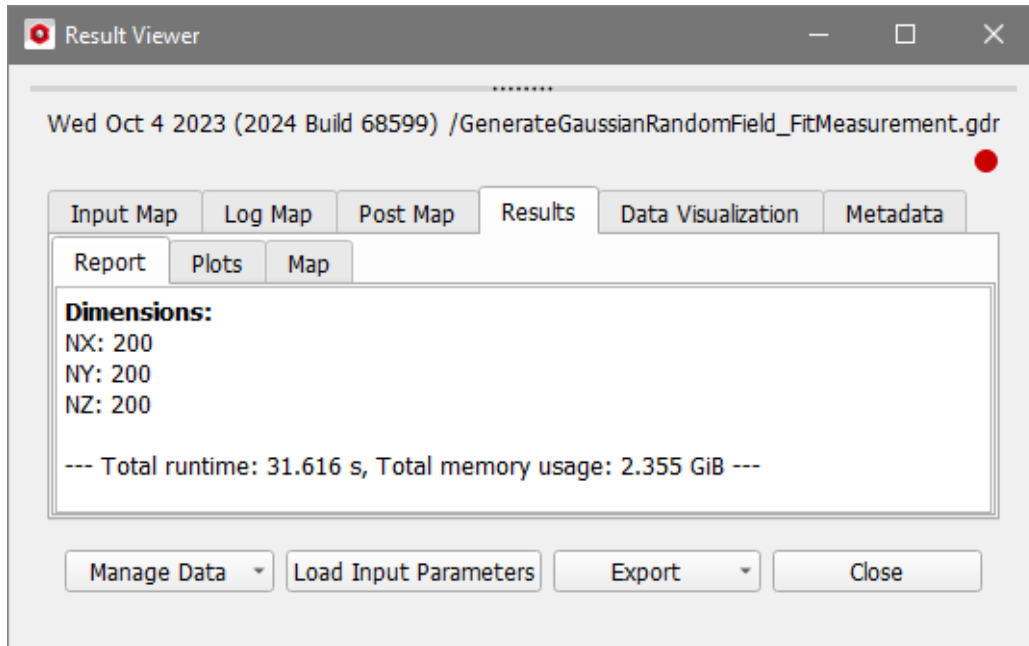

View the achieved covariances for the three dimensions in the **Plots** subtab of the **Results** tab. The red graph shows the **Achieved Covariance** in the resulting Gaussian random field. The blue plot shows the **Desired Covariance** which is the **Generator Input** prepared in the Gaussian Random Field Generator. How many numbered plots appear depends on the settings in the generator dialog. Here, the desired covariance is the sum of two **Gauss** functions.

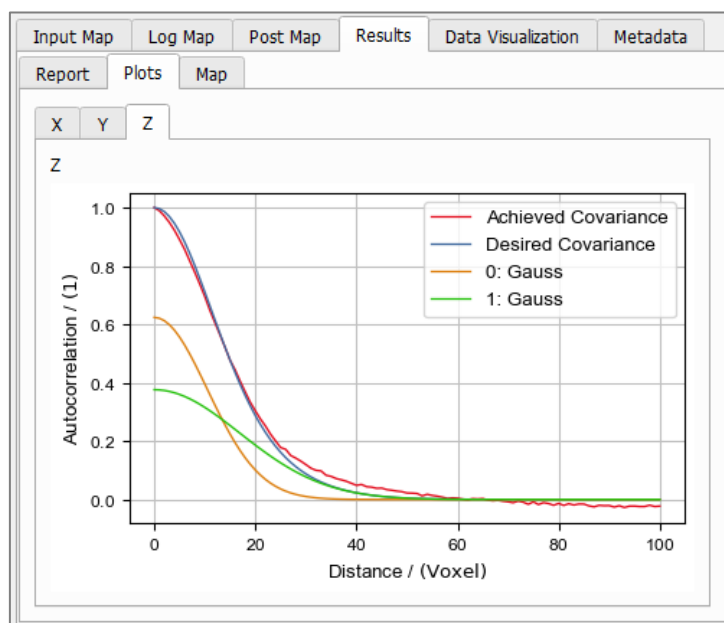

The Gaussian Random Field is visualized in GeoDict after the generation but can also be loaded at any time from the **Result Viewer**. In the **Data Visualization** tab click **Load Gaussian Random Field** and in the **Loading Volume File** dialog click **OK**.

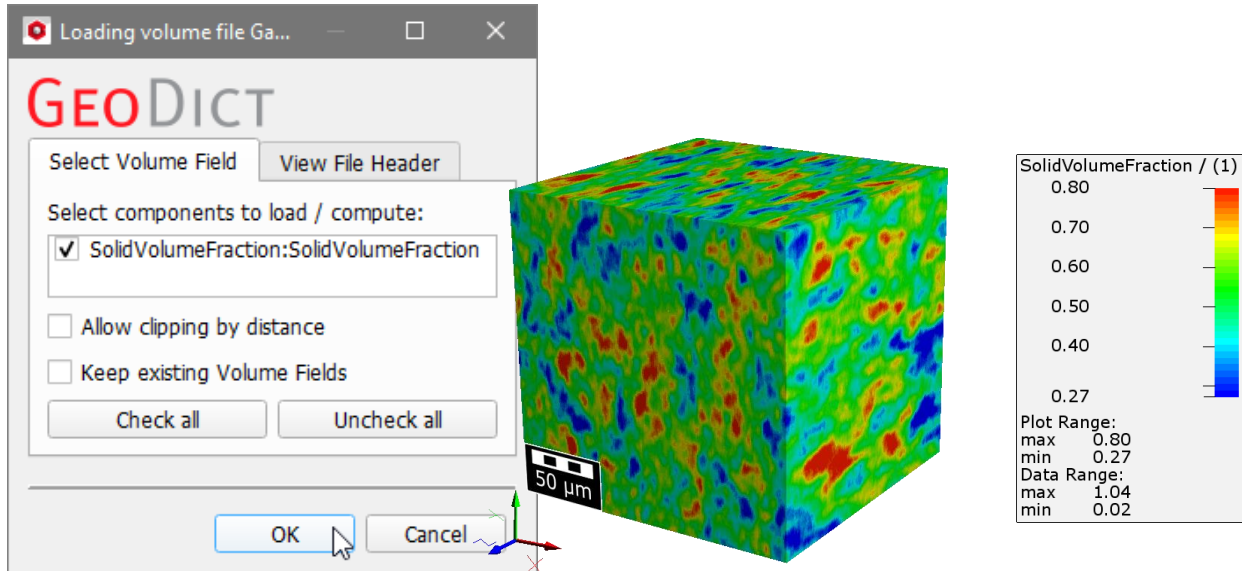
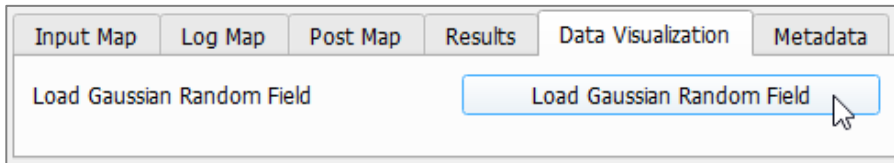

To learn more about visualization in GeoDict, refer to the [Visualization](#) handbook of this User Guide.

This volume field can be transformed into a structure by right-clicking on the field in the **Project Status** and selecting **Threshold to Structure**.

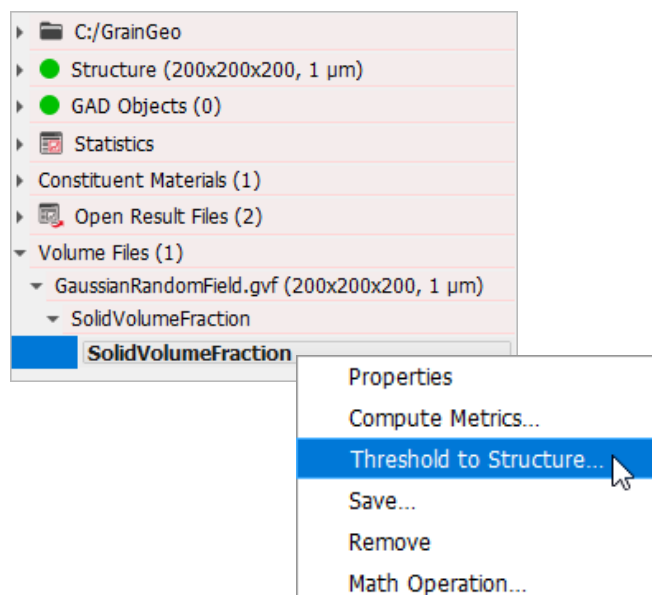

For one threshold, the resulting structure can be previewed in 3D.

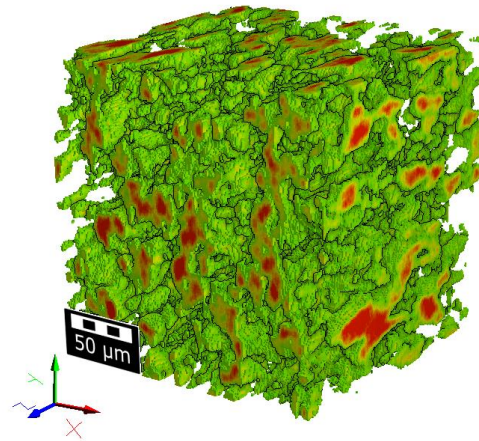
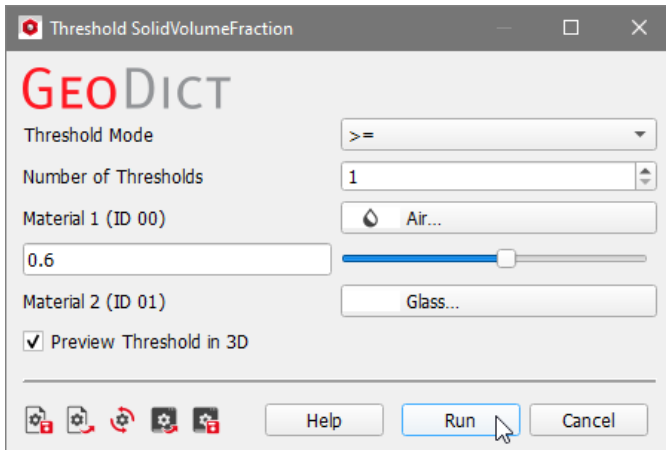

Edit the parameters as desired, and click **Run**.

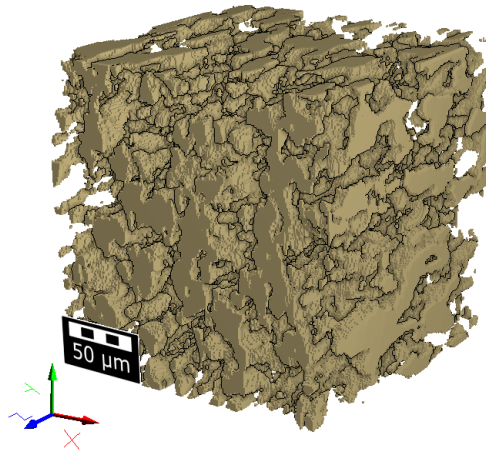
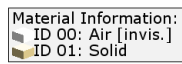

REFERENCES

[1] Ohser, J., Schladitz, K.: Spectral Analysis, 3D Images of Materials Structures: Processing and Analysis. Wiley-VCH Verlag GmbH & Co, (2009),

<https://doi.org/10.1002/9783527628308.ch6>.

Technical
documentation:

Janine Hilden
Sebastian Rief
Barbara Planas

MATH
2 MARKET

Math2Market GmbH
Richard-Wagner-Str. 1, 67655 Kaiserslautern, Germany
www.geodict.com