

Visualization of structures and result fields in **GeoDict**

User Guide

GeoDict release 2024

Published: February 15, 2024

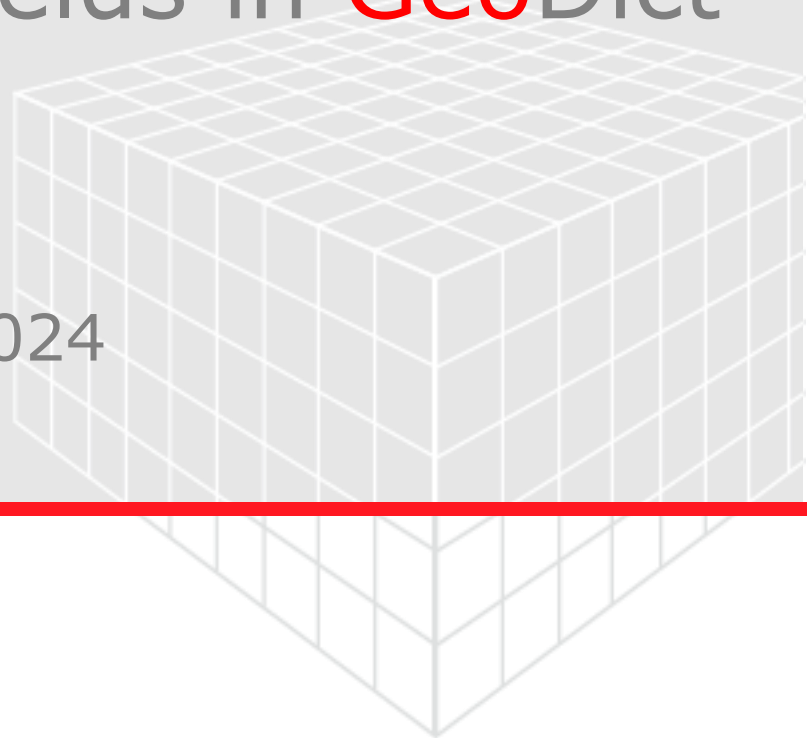

GEODICT

<https://doi.org/10.30423/userguide.geodict>

© Math2Market GmbH 2024

Citation:

Janine Hilden, Barbara Planas. GeoDict 2024 User Guide.
Visualization of structures and result fields in GeoDict handbook.
Math2Market GmbH, Germany, doi.org/10.30423/userguide.geodict

All rights reserved. It is not permitted to reproduce the book or parts thereof in any form by photocopy, microfilm or other methods or to transfer it into a language suitable for machines, in particular data processing systems, without the express permission of the publisher. The same applies to the right of public reproduction.

The handbooks in the User Guide series of Math2Market GmbH can be obtained from:

Math2Market GmbH
Richard-Wagner-Strasse 1
67655 Kaiserslautern
Germany

Phone: +49 631 205 605 0
Fax: +49 631 205 605 99
Email: info@math2market.de
Web: www.math2market.de

VISUALIZATION IN GEO_DICT 2024	1
INTRODUCTION	1
REQUIREMENTS	1
VISUALIZATION ELEMENTS IN THE GUI	3
A. VIEW MENU	4
B. SETTINGS MENU	6
Color & Visibility Settings	6
C. VIEW CONTROLS AND VISUALIZATION AREA	12
View Controls for 2D Cross Section View	14
View Controls for 3D Rendering	16
D. VISUALIZATION TAB AND COLOR & VISIBILITY TAB	18
SETTING VISUALIZATION OPTIONS FOR DATA DISPLAY	21
SETTING VISUALIZATION OPTIONS FOR 2D CROSS SECTION VIEW	23
Camera	23
Structures - Geometry data	27
Result fields – Property data from simulations	30
SETTING VISUALIZATION OPTIONS FOR 3D RENDERING	43
Camera	44
Structures - Geometry data	47
Result fields – Property data from simulations	53
LEGENDS AND OVERLAYS	89
Legends and Overlays for 2D Mode	90
Legends and Overlays for 3D Mode	95
REFERENCES	99

VISUALIZATION IN **GeoDict** 2024

INTRODUCTION

For visualization, **GeoDict** distinguishes two concepts: structure (or geometry-related data) and result fields (or property-related data).

- **Structures** can be created as output data from **GeoDict**'s generation modules (ending in **Geo**) or imported with **GeoDict**'s import modules (beginning with **Import**). They are input data for **GeoDict**'s material properties prediction modules (ending in **Dict**).
- **Result fields** are the output data of **GeoDict**'s material property prediction modules. Using result fields **GeoDict** provides great visualization options for the simulation results.

REQUIREMENTS

GeoDict uses OpenGL to visualize structures and results in 3D. **GeoDict** is compatible with the oldest possible OpenGL version (1.1), which is guaranteed to be available in any Windows system. However, some visualization features require more advanced OpenGL versions:

- rendering animated streamlets requires OpenGL 2.0
- rendering spherical particles requires OpenGL 3.3. If this version is not available, a much slower fallback solution is used.

On Windows remote desktop sessions, usage of hardware acceleration is only possible with NVidia Quadro cards of the series x000. This limitation can be avoided if Windows Remote Desktop Acceleration of [NVidia DesignWorks](#) is used.

If no hardware acceleration is present, Mesa software rendering is used automatically. The necessary Mesa libraries are included in the **GeoDict** installation folder.

For Linux remote sessions, we recommend using VirtualGL and TurboVNC for remote 3D rendering. The installation of these tools is described in the [High Performance Computing](#) handbook of the User Guide.

It is also possible to connect from a Linux terminal to a Linux server using **ssh -X**, without the installation of VirtualGL and TurboVNC. In this case, visualization in 3D is only possible when **Indirect GLX** is enabled on the Linux terminal (it is not necessary to enable this on the Linux server that runs **GeoDict**, but it must be enabled on the terminal that runs the X11 server). By default, this option is disabled in many cases. The status of this option can be checked with

```
grep -i "Indirect" /var/log/Xorg.0.log.
```

Output is, for example:

```
[1344382.166] (II) Indirect GLX disabled.
```

To enable this option is not straightforward, works differently on different Linux systems or different graphic cards, and often requires a system administrator to change the config files of the system. For example, on Ubuntu 14.04 LTS it is

necessary to include the option `+iglx` in the file `/usr/share/lightdm/lightdm.conf.d/50-xserver-command.conf`:

```
[SeatDefaults]
# Dump core

xserver-command=X -core +iglx
```

Because of this complexity in the setup, we recommend in general to use TurboVNC for remote logins instead of `ssh -X`.

VISUALIZATION ELEMENTS IN THE GUI

For in-depth analysis of simulation results, images of geometries and images of properties can be displayed in 2D cross-section (SEM) view and in 3D rendering.

Different features are available for visualization in 2D and in 3D. A great number of attributes and features may be toggled and adjusted to complement and enhance the images' visual information.

The activation of these **GeoDict** visualization features is governed directly through four points of access in the **Graphical User Interface** (GUI):

- A. **View menu** in the Menu bar
- B. **Settings menu** in the Menu bar
- C. **View Controls** above the Visualization area, are greyed out if no structure is loaded in memory.
- D. **Visualization tab** and **Color & Visibility tab** in the GUI **Sidebar**, both are expandable and may be undocked.

The **GeoDict** GUI at the start of the program is partitioned into **Menu bar**, **Toolbar**, **Project Status section**, **Module section**, **Visualization area**, the expandable tabs in the GUI **Sidebar**, and the **Console & Notifications** section:

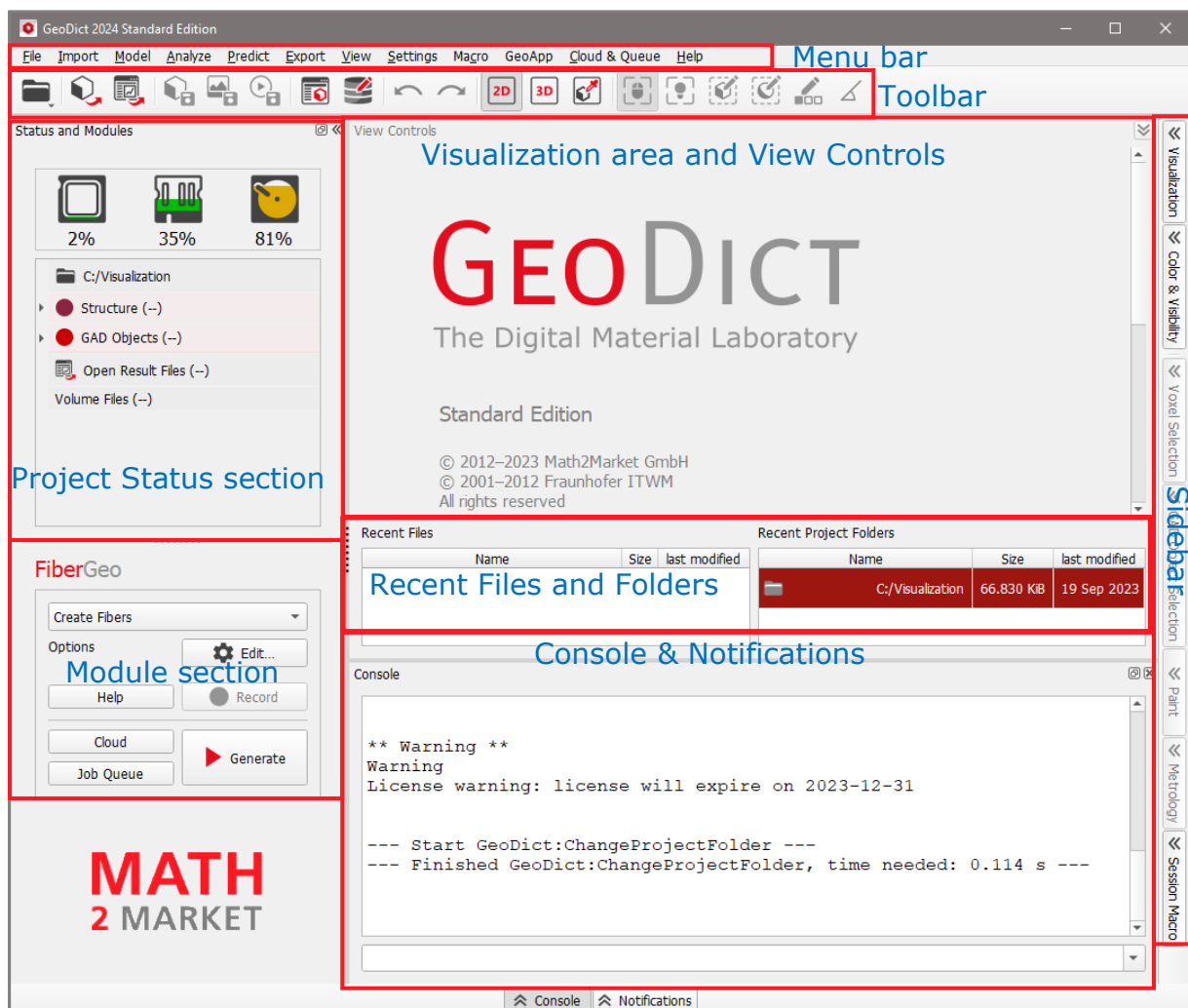

A. VIEW MENU

When a structure is loaded, choosing between the **View** menu entries changes the visualization settings. A shortcut to many of these parameters can also be set through the tabs in the GUI **Sidebar**, as explained starting in page [18](#).

The **View** menu allows to:

- choose the visualization type to be **2D Cross Section (SEM)**, or **3D Rendering**, with **3D Structure Renderer** and **3D View Ratio**
- display the Visualization area in **Full Screen**
- select which components are displayed in the **visualization area**, and
- choose the **Legends / Overlays** to be displayed.

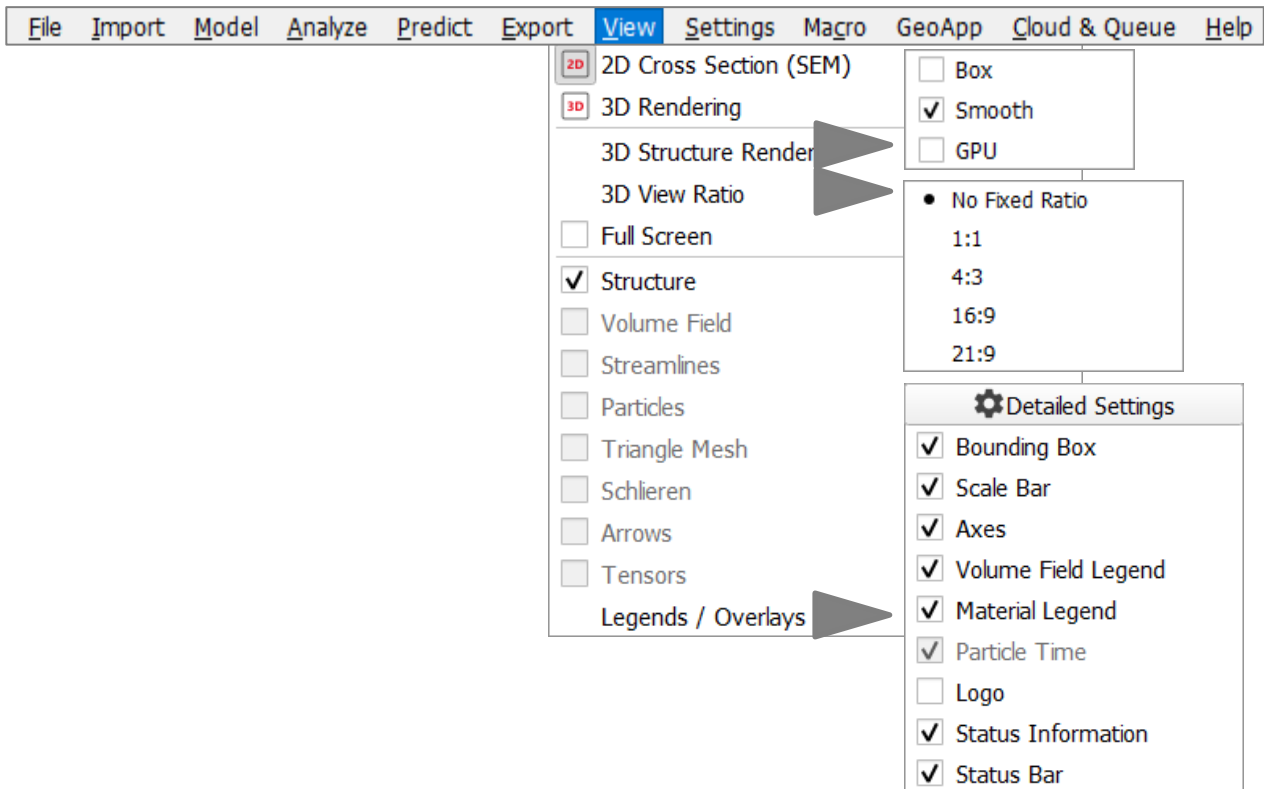

Some of these options are only accessible when choosing to visualize in **3D Rendering** or when visualizing solver results (**Volume Field**, **Streamlines**, **Particles**, **Triangle Mesh**, **Schlieren**, **Arrows**, and **Tensors**).

Selecting **Full Screen** makes the **Visualization area** occupy the entire screen. Pressing the **Esc** key on the keyboard returns the program to the normal display, containing all the components of the **GeoDict** GUI layout.

In **3D Rendering**, the structure can be rendered using the graphics card (**GPU**) or the main processor (**Box** with raycasting or **Smooth** with raycasting). Volume raycasting is an image-based volume rendering technique that computes 2D images from 3D volumetric data sets. Examples to these options can be found on page [48](#).

When un-checking **Structure**, the complete structure model disappears from the display.

Among the choices for the visualization of computational results (after running, for example, a flow solver computation, a filtration simulation, or generation of a

triangulation mesh) are the display of flow **Volume Field**, **Streamlines**, **Particles**, **Triangle Mesh**, **Schlieren** (Line Integral Convolution), **Arrows**, and **Tensors**.

To start the visualization of computational results, result fields must be loaded by selecting **File** → **Load Volume Field...** in the menu bar, or directly by clicking **Load** or **Load Volume Field** in the Result Viewer of a **GeoDict** result file (*.gdr).

Among the **Legends / Overlays**, the checked **Bounding Box** activates the border surrounding the domain in **3D Rendering**. **Scale Bar** or **Axes** activate the scale bar and/or the coordinate stencil in the lower left corner of the display in **2D Cross Section (SEM)** or in **3D Rendering**.

Unchecking **Volume Field Legend** and/or **Material Legend** hides the legends with information on the computational results after running calculations or on the constituent materials (Material IDs) present in the structure.

Clicking  **Detailed Settings** in the **Legends / Overlays** menu, unfolds the corresponding settings in the **Visualization Settings** dialog (Sidebar → Visualization tab → Legends / Overlays section).

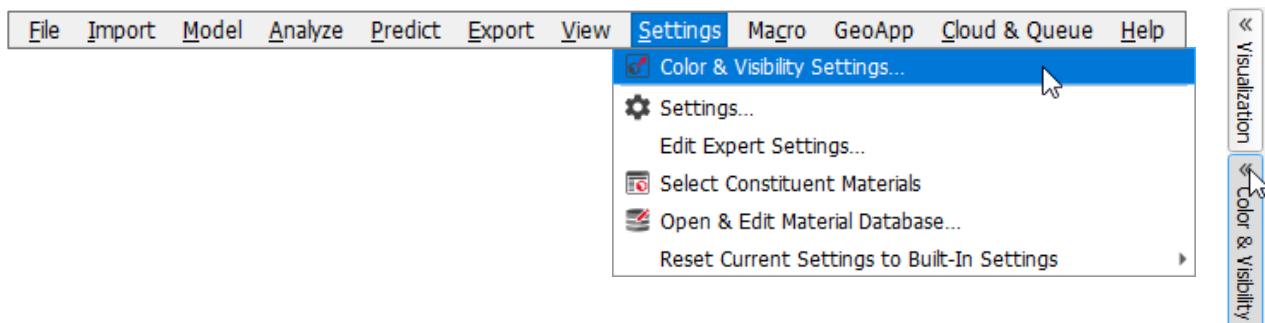

B. SETTINGS MENU

The **Color & Visibility Settings** are available from the **Settings** menu in the menu bar,.



Selecting it in the menu bar has the same effect as selecting the **Color & Visibility tab** in the GUI **Sidebar** on the right side, or clicking the  icon in the toolbar.

COLOR & VISIBILITY SETTINGS

In all three cases, the **Color & Visibility Settings** open as a panel that can be also undocked from the GUI by clicking . The **Color & Visibility Settings** can be collapsed either by clicking  in the upper right corner or by re-clicking the **Color & Visibility tab** in the GUI **Sidebar**.

The undocked **Color & Visibility dialog** can be closed with the red  in the upper right corner.

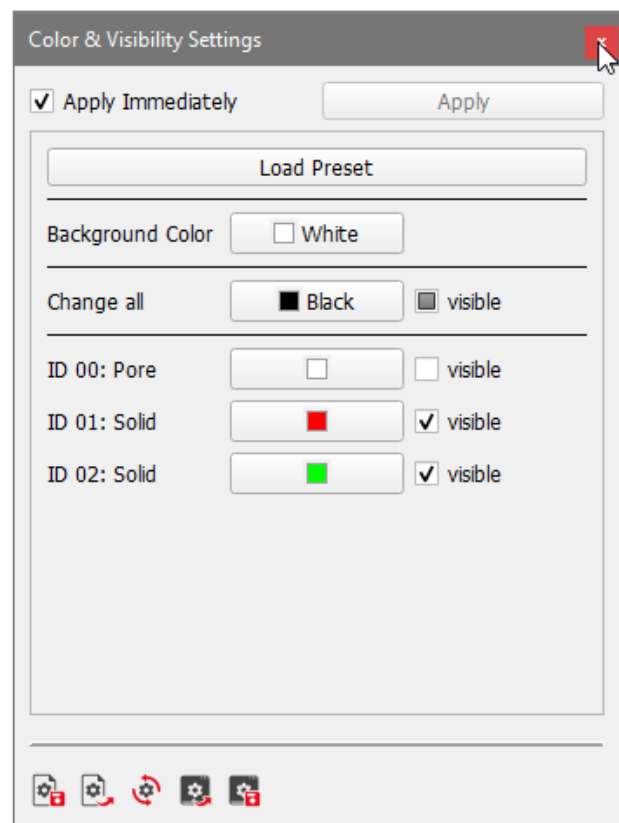
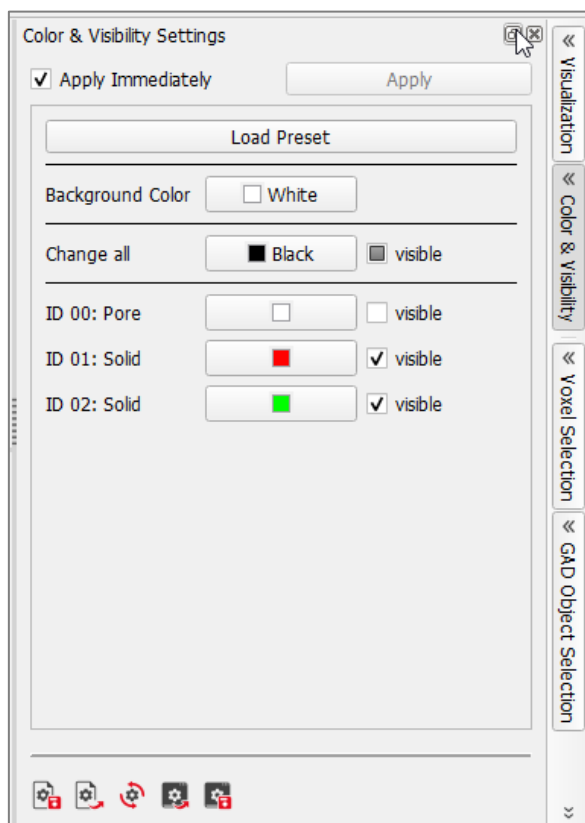

The default color settings, applied to the background and materials during the generation with **GeoDict**, can be changed through the **Color & Visibility Settings** dialog. While up to 256 material IDs can be present in a structure, only the colors for the IDs contained in the current structure can be edited.

All settings changed in the **Color & Visibility Settings** dialog are applied directly if **Apply Immediately** is checked. When the checkbox is disabled, the **Apply** button next to it is enabled to apply the changes only when desired.

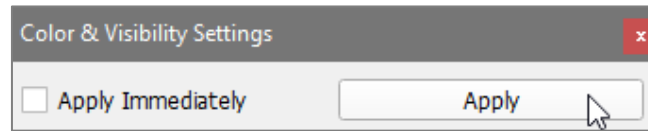

A color preset is a group of colors that are applied together.

Click **Load Preset** and, in the **Load Color Preset** dialog, select whether to display the generated structure's material using one of the presets.

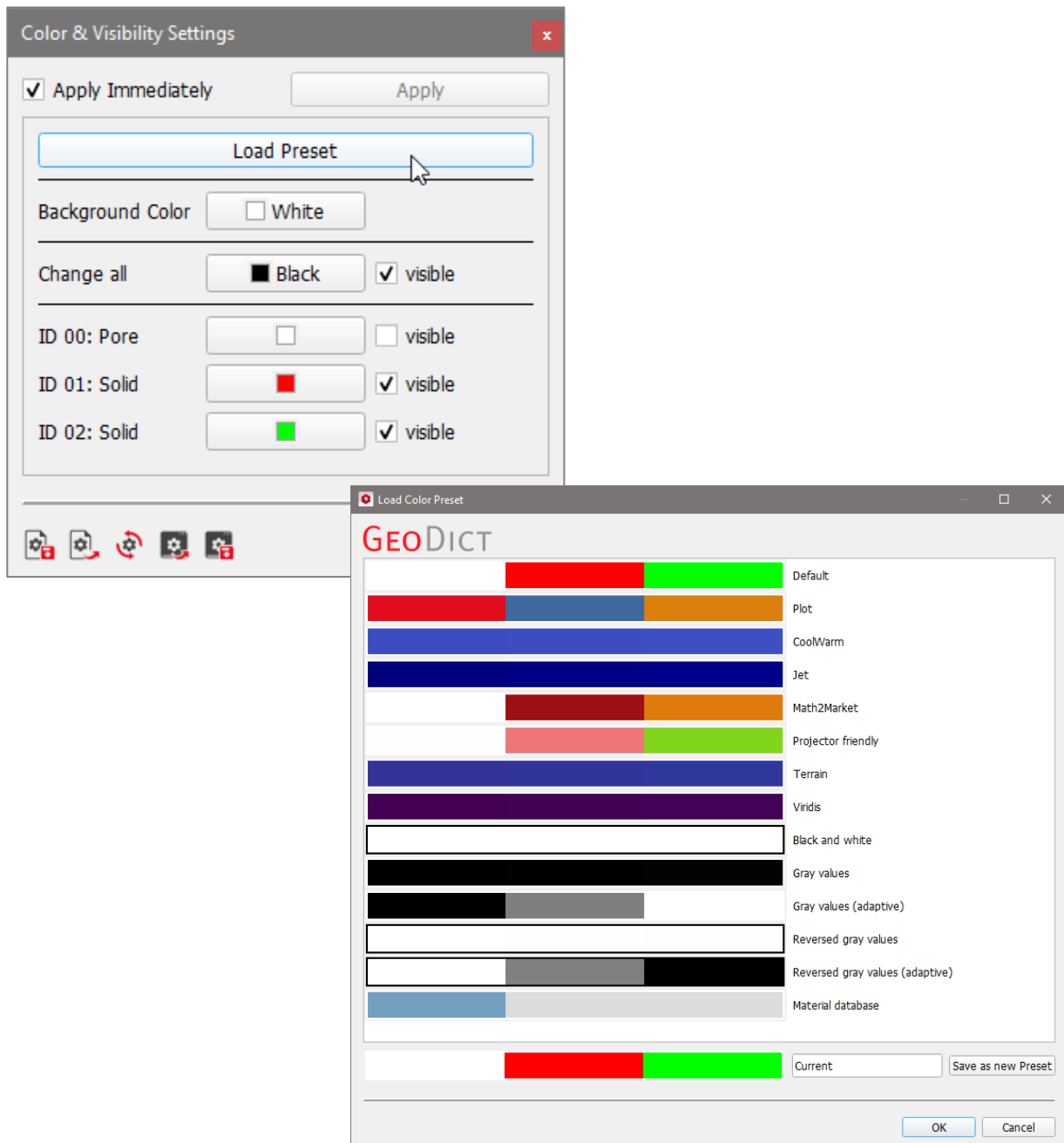

The number of colors shown in the preset previews depends on the number of materials present in the current structure. If for example 100 IDs are present, the dialog looks as follows:

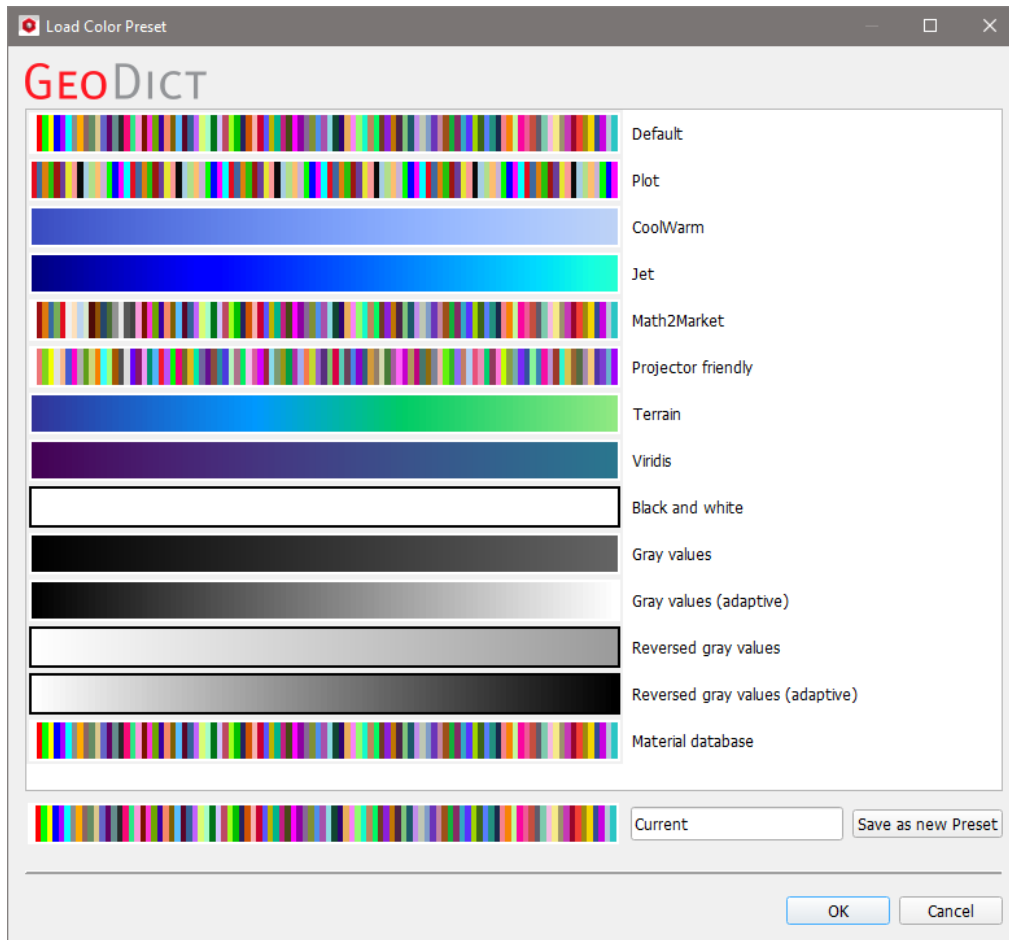

The user may select new colors through the buttons in the **Color & Visibility Settings** dialog and save the current group of colors as a preset (**Save as new Preset**), to have it appear in the list of color presets later.

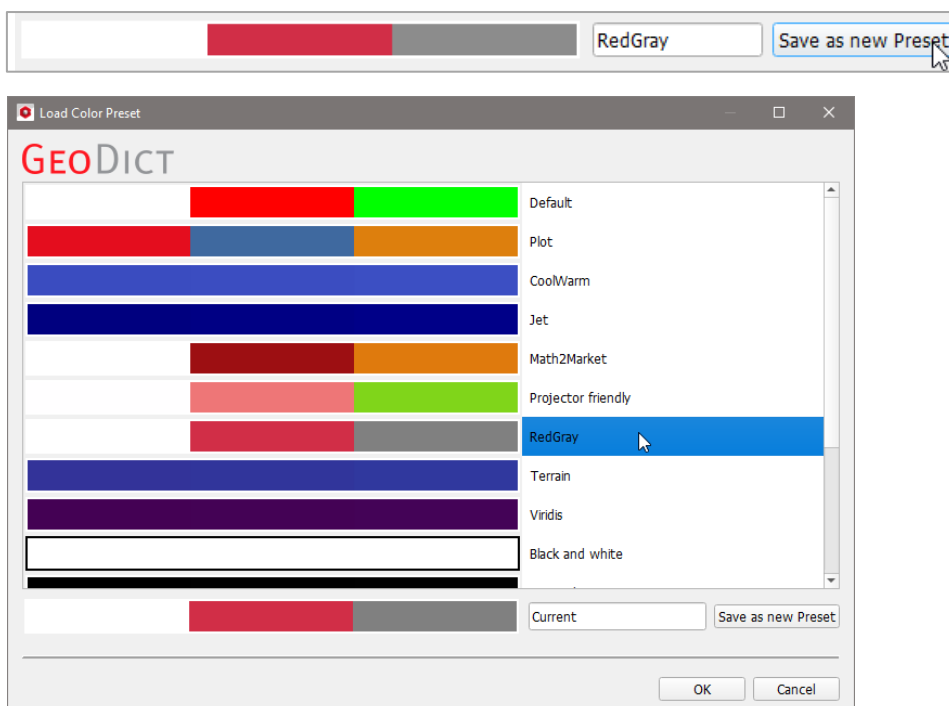

The preset can be removed anytime by right-clicking on it and selecting **Remove Selected Item**.

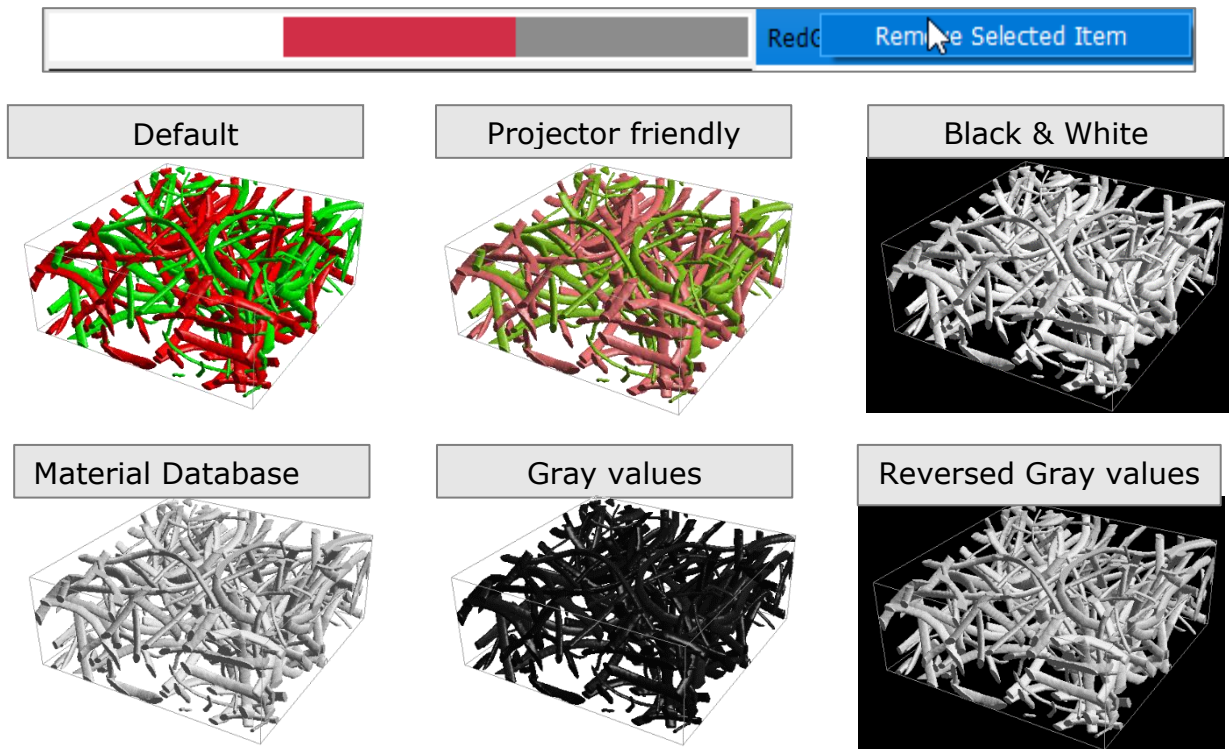

The visibility of the materials in the structure, for example of Material **ID 01**, is controlled by checking or unchecking **visible**. In the example below, material **ID 01** is still present in the structure, but it is just not visible.

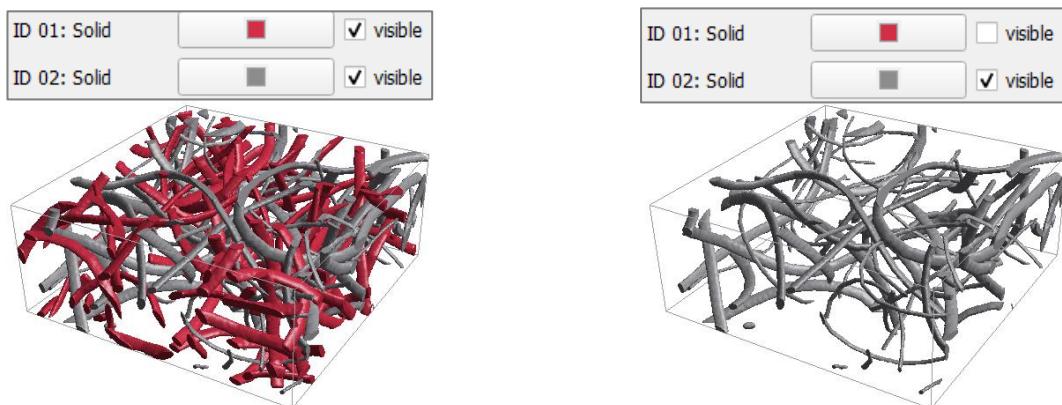

By default, the Material **ID 00** is the background material surrounding the objects, inside the domain indicated by the bounding box. In the default settings, the visibility of Material ID 00 is un-checked, to be able to see the objects in the structure in 3D rendering, and the color is white.

The color and visibility of Material ID 00 can be changed. In this example, this has the effect of showing a block in 3D rendering that corresponds to the domain, in the color selected for Material ID 00 (here, orange).

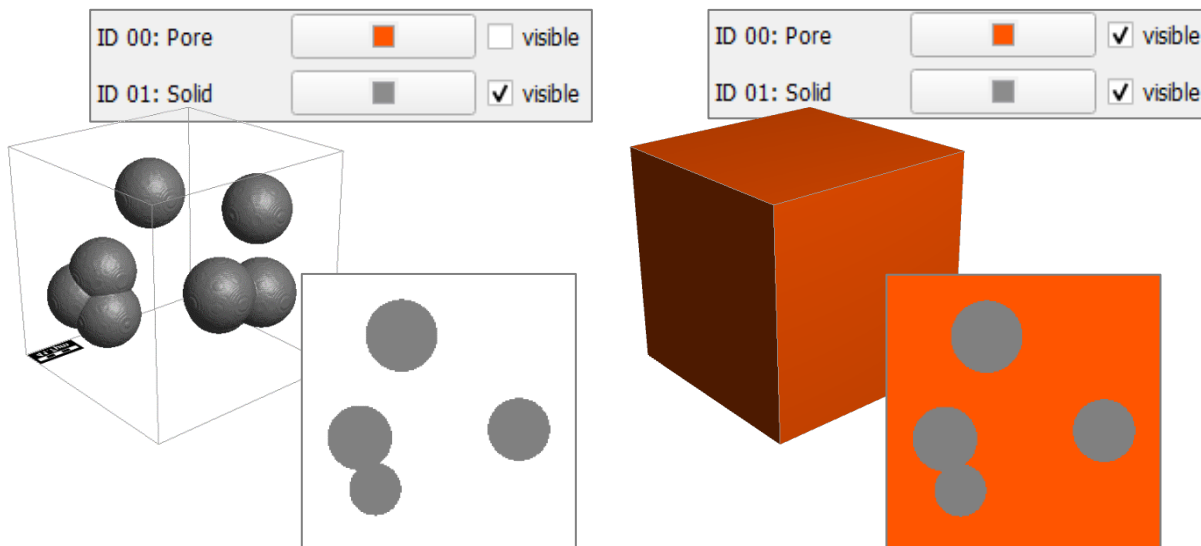

To change the color selected for a material from the default (e.g., Dark gray) to another color (e.g., yellow), click the button for the color (here: dark gray) and select the yellow color from the table.

To change the default color to a user-defined color, select the three-dots icon.



In the opening **Select Color** dialog enter the RGB values that define the color and click **Add to Custom Colors**. Alternatively, the rectangle for the new color can be dragged to occupy the place of the old one in the custom colors.

The new color setting is applied to the material after clicking **OK**.

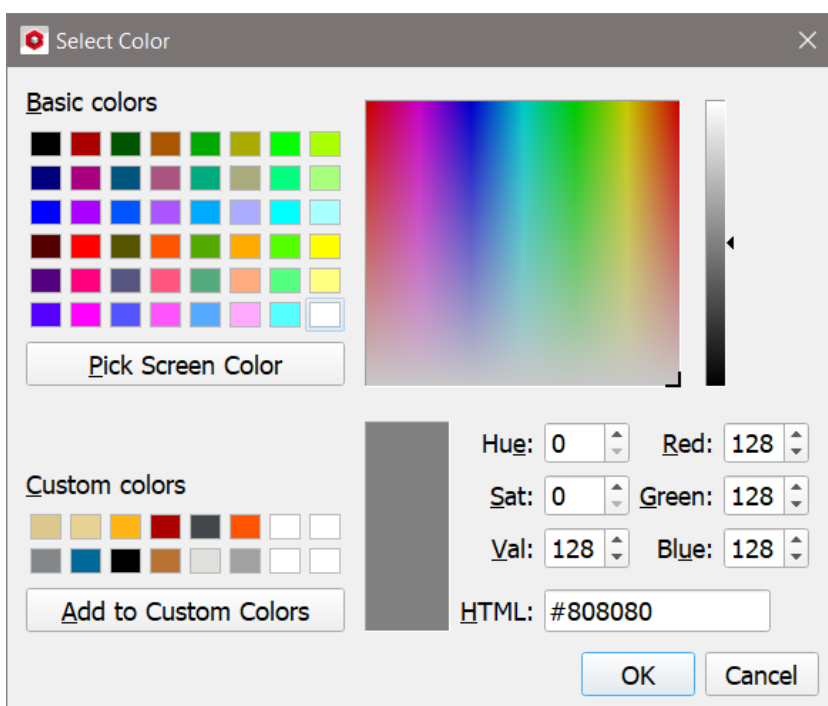



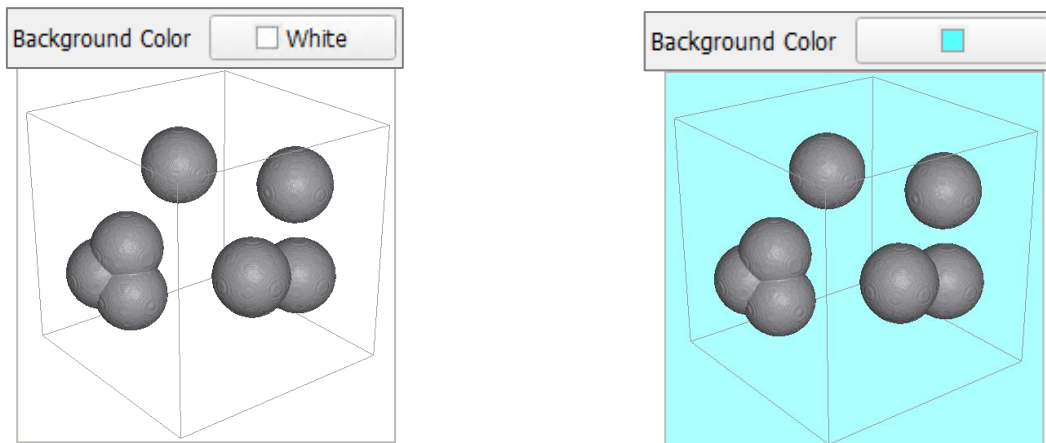

The **Background Color** of the Visualization area, at the top of the Color & Visibility Settings dialog, can be changed in the same way.

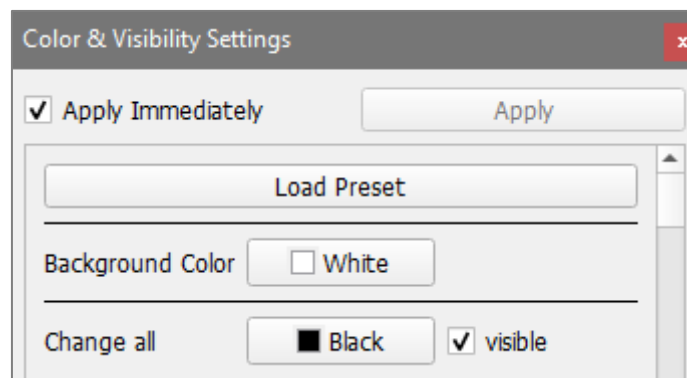

The color and the visibility can be changed for all materials at once in the **Change all** line below the **Background Color** line. As soon another color is selected, the color for all material IDs is set to the chosen color. If unchecking (checking) the **visible** checkbox, all material IDs are set to invisible (visible).



The icons at the bottom of the dialog can be used to:

-  **Save current settings to file:** the new color settings can be saved into *.gps (GeoDict Project Settings) files (e.g., **ColorSettings.gps**) and later loaded to be reused.
-  **Load settings from file:** saved color settings can be loaded.
-  **Load built-in default settings:** the default colors can be reloaded.
-  **Load start-up settings:** load the color settings that have been set as start-up settings.
-  **Set current settings as start-up settings:** set the current color settings as start-up settings.

Resting the mouse pointer over an icon shows a tooltip explaining the icon's function.

C. VIEW CONTROLS AND VISUALIZATION AREA

At the program start, the **Visualization area** shows the GeoDict splash screen. When structures or result fields are loaded in GeoDict, they are shown in the **Visualization area** and the **View Controls** panel appears above it. The displayed image might be of a fibrous-, paper-, granular-, sintered-, pleated-, woven-, or grid-structure created with one of GeoDict's structure generators, an image from an opened *.gdt file, an image imported and segmented with **ImportGeoVol** or **ImportGeoCAD** from a stack of 3D image data (μ CT, FIB/SEM), or other structure models.

The **View Controls** panel shows information and options for the visualization of the image displayed in the **Visualization area**. The items shown in the **View Controls** and the image display in the Visualization area are closely related. They are influenced and change accordingly with the parameters selected in the **View** menu and in the **Visualization tab** and the **Color & Visibility tab** of the GUI **Sidebar** (see pages [18ff](#) and [6ff](#), respectively).

The **View Controls** panel is organized into tabs with the controls for structure visualization and result fields computed for it (and accessible through the result file).

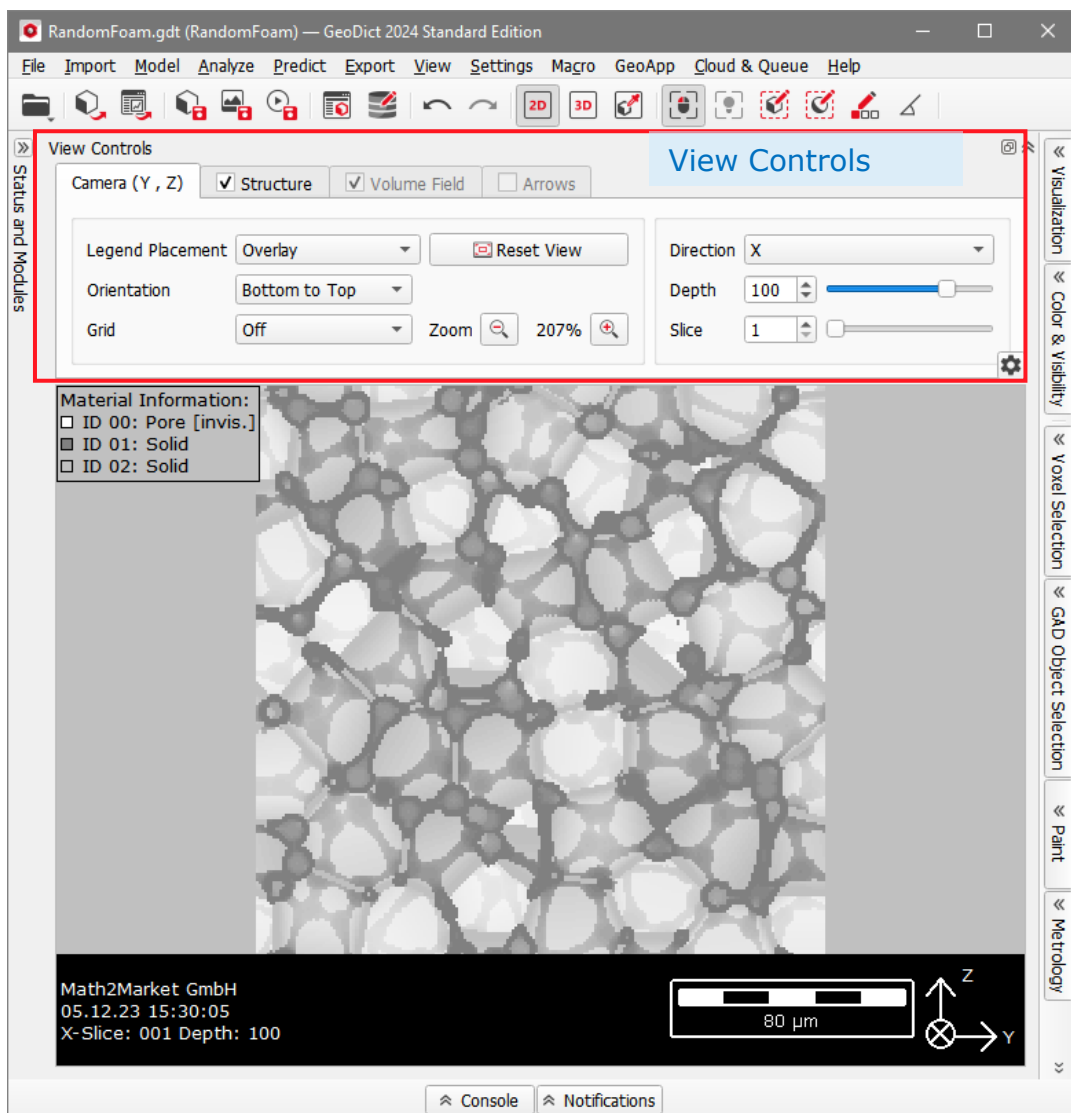

See below starting in page [21](#) for information on setting the options in the **View Controls** tabs to optimize the visualization of images from geometry data and property data.

Visualization elements in the GUI – Visualization panel and Visualization area

Collapse the **View Controls** panel by clicking  in the upper right corner.

The **View Controls** panel can be undocked by clicking the corresponding icon  in the upper right corner. Close it by clicking  in the upper right corner.

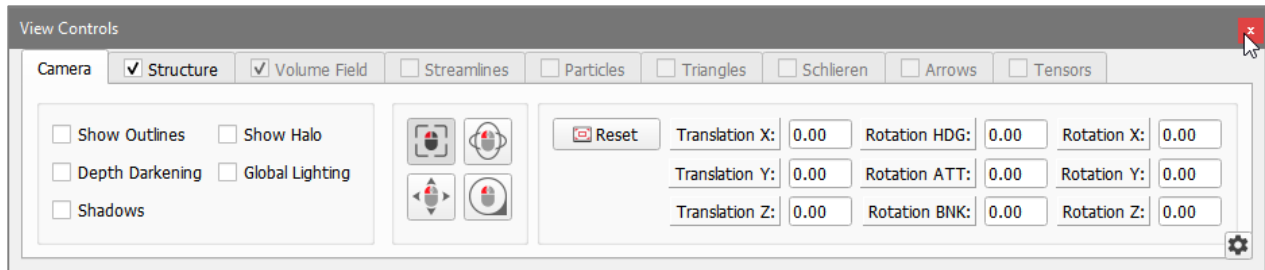

The image in the Visualization area might be a 2D or 3D image of any structure model generated with one of GeoDict's structure generators. The displayed image of a structure may originate also from an opened *.gdt file, the GeoDict format, an image imported with ImportGeo from a stack of 3D image data (μ CT, FIB/SEM), or other geometry models.

The visualization in 2D or 3D changes the **View Controls**, by activating other tabs to access features for the visualization of geometry data or result data.

2D View

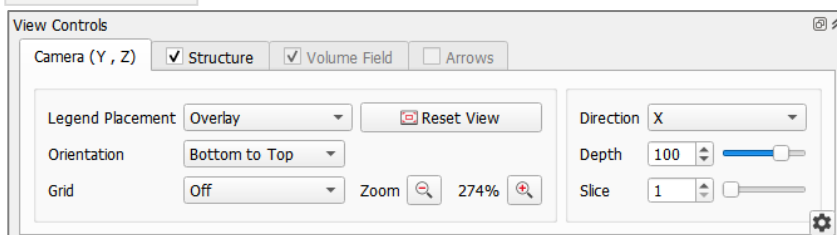

3D Rendering

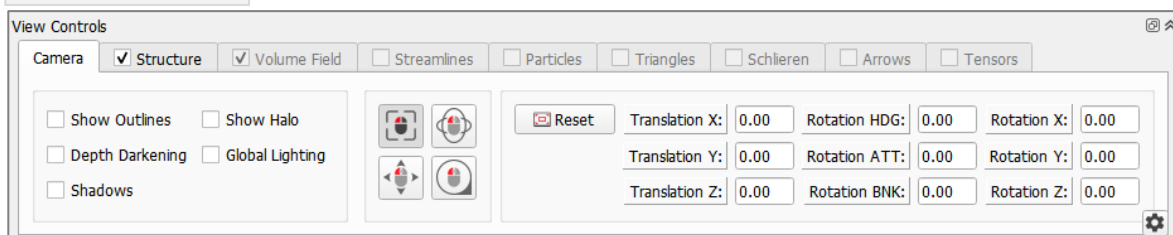

In 2D Cross Section and in 3D Rendering, **zoom** by keeping the right button pressed and simultaneously moving the mouse forward. By moving the mouse backward, the image zooms out.

In 3D Rendering, zooming is also possible by scrolling the mouse wheel.

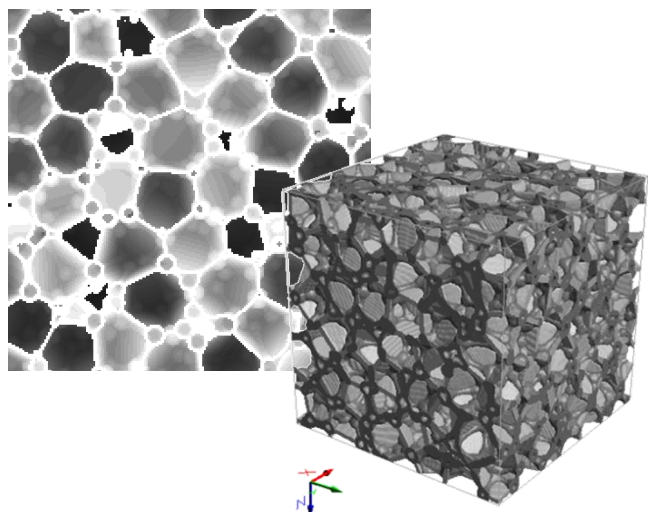

VIEW CONTROLS FOR 2D CROSS SECTION VIEW

In 2D cross section view, the **Visualization area** shows a slice of the current image of a structure or result field and the positioning of the camera can be set in the **View Controls**, with the controllers of the 2D view, under their tabs.

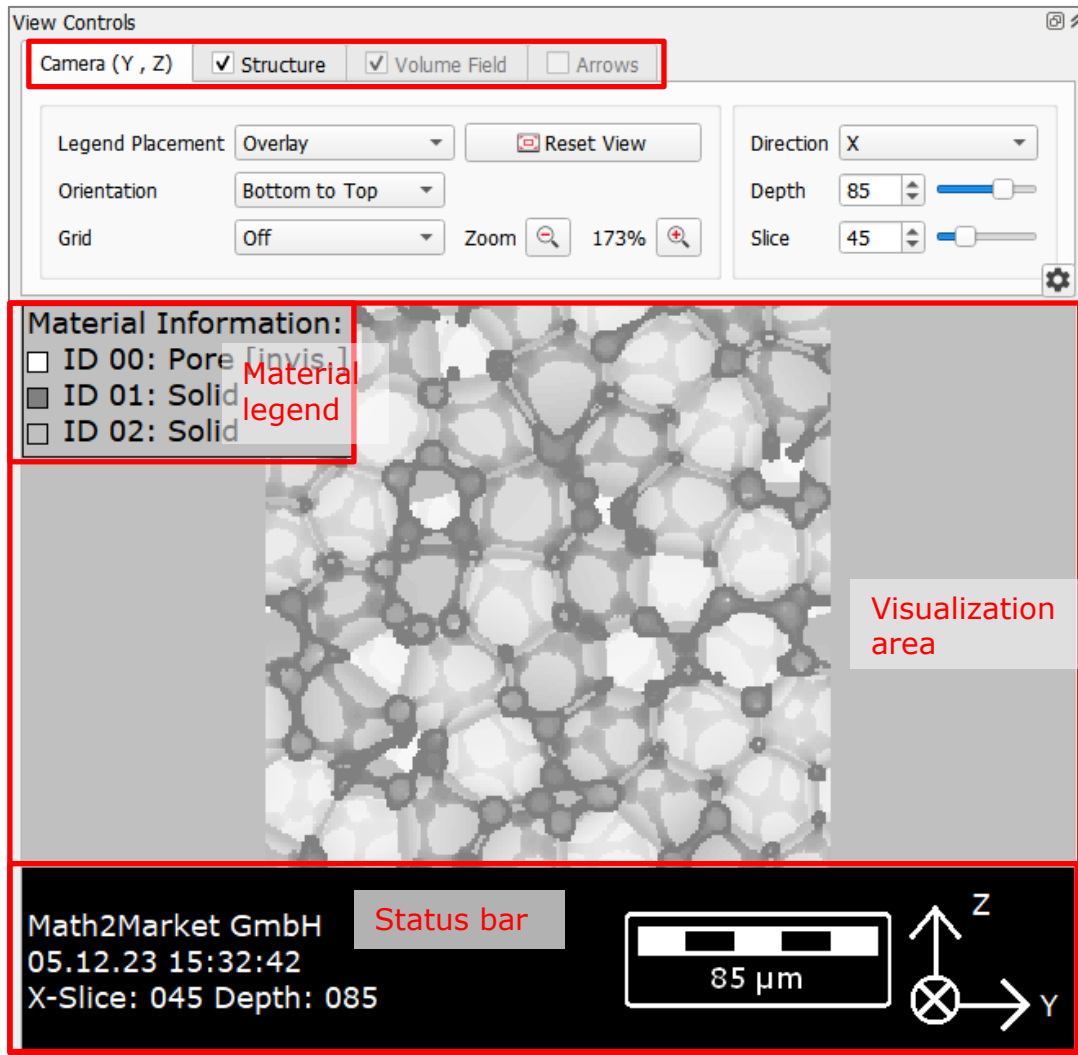

The 2D image itself is displayed in the center of the Visualization area. Zoom either stepwise with the **Zoom** icons in the **Camera** tab or smoothly by keeping the right mouse button pressed and simultaneously moving the mouse forward. By moving the mouse backward, the image zooms out.

As long the structure is not zoomed out to be smaller than the domain width, it can be **moved** within the visualization area by pressing and holding the left mouse key and dragging it around.

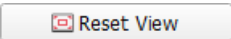
The zoom and the position in the Visualization area can be reset by clicking  in the **Camera** tab.

Also, in the Visualization area, the **Material Legend** shows information on the colors and materials IDs used for the objects in the structure. GeoDict's material concept and the material database are described in the [Material Database](#) handbook.

As described above in pages [7ff](#), the colors for the materials can be changed through **Settings** → **Visibility & Color Settings**, through the icon  in the toolbar, or by unfolding the **Color & Visibility tab** of the GUI **Sidebar**.

Visualization elements in the GUI – Visualization panel and Visualization area

The Material IDs can be changed through **Settings** → **Select Constituent Materials...** in the menu bar or the  icon in the toolbar.

At the bottom of the Visualization area, the **Status Bar** shows information about the visible slice and direction. When switched on, a scale bar shows the physical size of the visible image.

VIEW CONTROLS FOR 3D RENDERING

After selecting **3D Rendering** view, the available settings for the tabs are changed in the **View Controls** and more tabs become available:

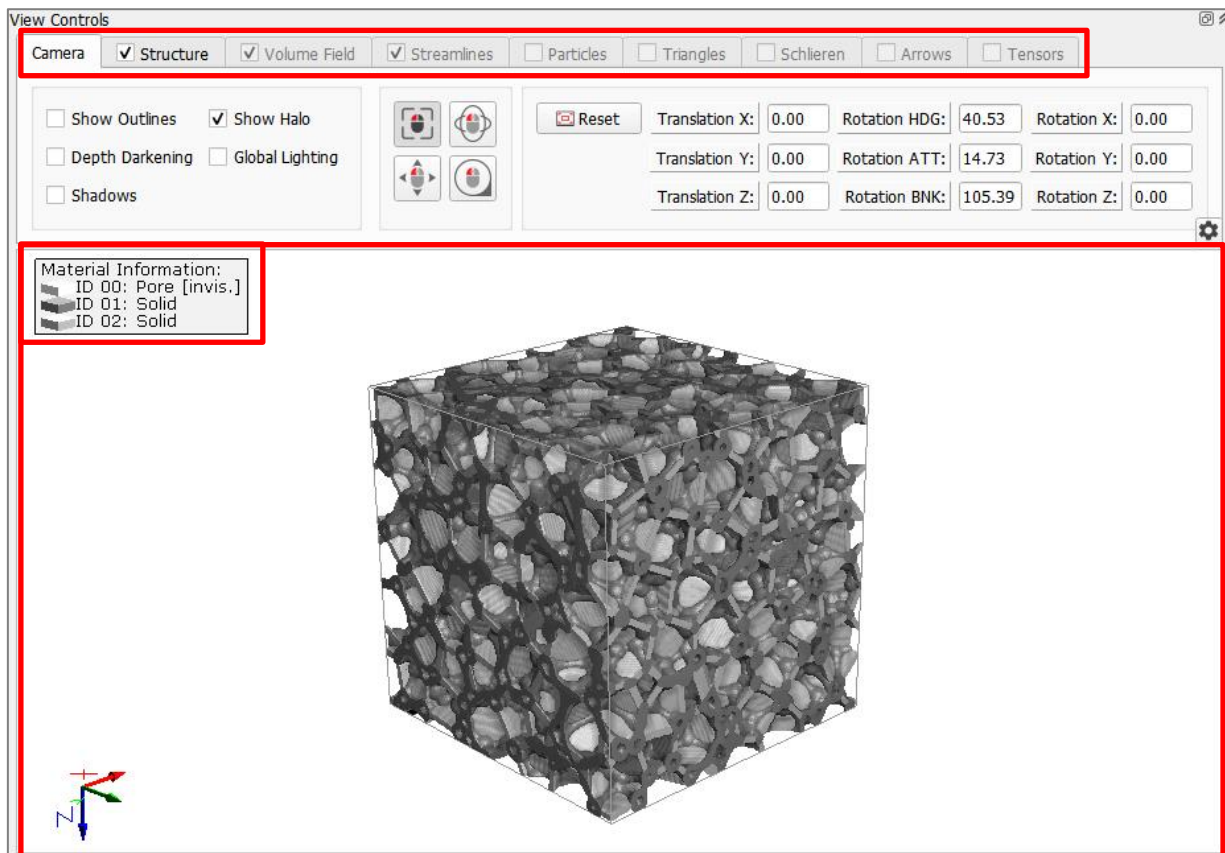



In the Visualization area, below the **View Controls**, the **Material Legend** shows information on the colors and materials IDs used for the objects in the structure.

With **3D Rendering** view selected, the structure image can be **rotated** by placing the cursor on the Visualization area, keeping the left mouse button pressed and moving it. Change the **focus point** for the rotation by double-clicking in the visualization area. Then, the structure can be rotated around this point.

Zoom by keeping the right button pressed and simultaneously moving the mouse forward. By moving the mouse backward, the image zooms out. Zooming happens also by scrolling with the mouse wheel.

Pan the structure around by keeping the middle mouse button pressed and simultaneously moving the mouse in the desired direction.

The source of light falling on the structure can be changed by moving the mouse while keeping the **CTRL** key and the left mouse button pressed.

Also, the light source can be easily changed, by clicking the  icon in the toolbar. Then, a beam spot appears in the Visualization area near the structure model. Move the mouse with the left mouse button pressed to observe the changing position of the light source. The beam spot disappears after clicking the  icon in the toolbar and moving the mouse.

Visualization elements in the GUI – Visualization panel and Visualization area

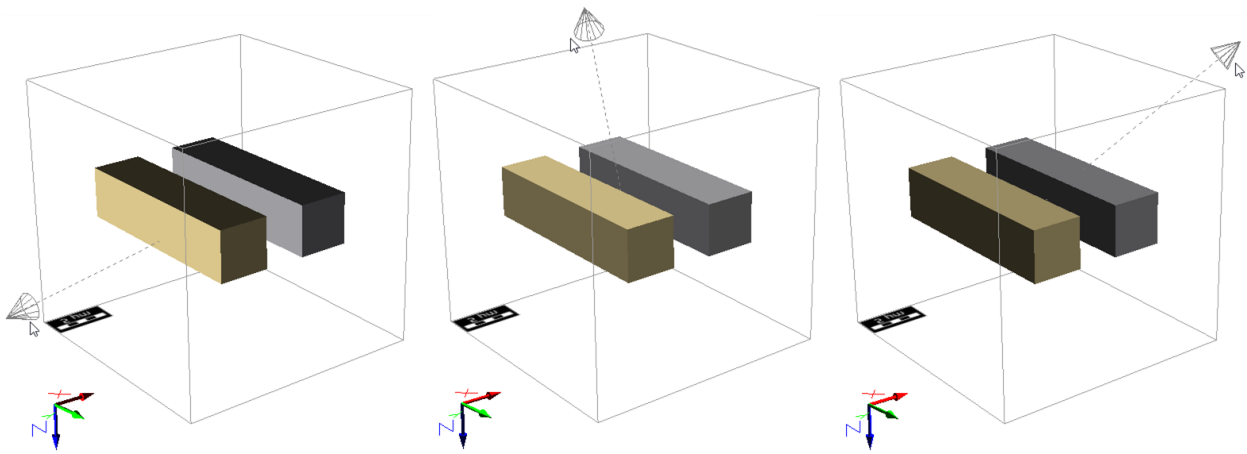

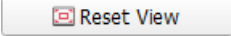

The camera and light positions can be reset by clicking  in the **Camera** tab.

D. VISUALIZATION TAB AND COLOR & VISIBILITY TAB

The **Visualization Settings** dialog unfolds when clicking the **Visualization tab** in the **Sidebar** of GeoDict and it covers and combines most parameters, commands, and settings that are located in the menu bar and in the **View Controls**, and also some additional parameters.

Thus, it allows to set all values for the visualization of structures and results fields obtained with GeoDict. Some of these parameters are redundant and also displayed in the **View menu** in the menu bar and the **View Controls**, but are duplicated in the GUI **Sidebar**. Others only are available the **Sidebar**.

Collapse the **Visualization Settings** again either by clicking  in the upper right corner or by clicking the **Visualization tab** in the sidebar.

The **Visualization Settings** can be undocked by clicking the corresponding icon  in the upper right corner. Close it by clicking  in the upper right corner.

In the following pages, many instances of the doubling are shown. For example:

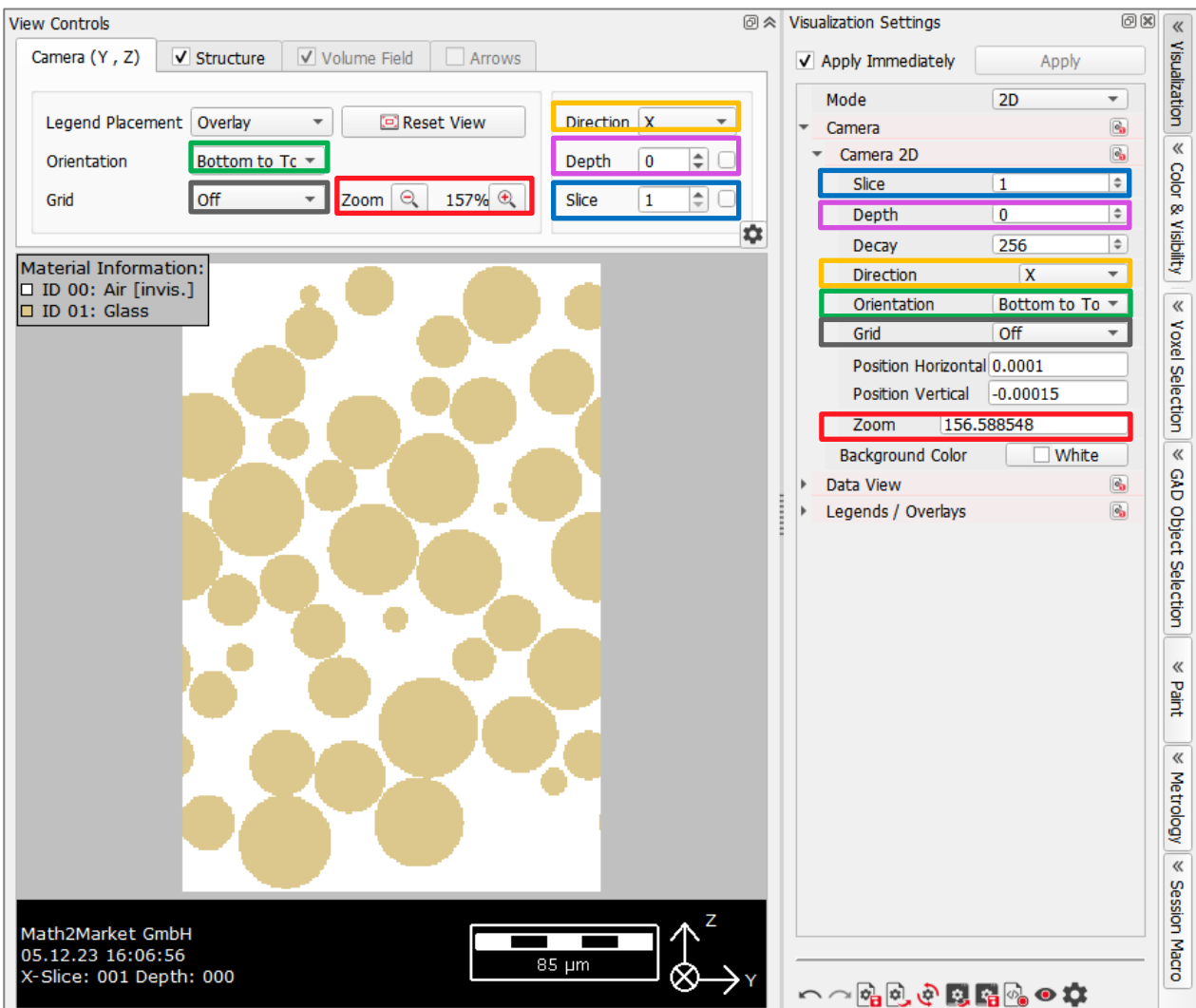

Initially, only visualization settings related the structure currently displayed in the Visualization area are shown in the dialog.

The **Visualization Settings** dialog expands automatically to the location of parameters that directly apply to the visualization settings of what is being displayed

in the Visualization area, when clicking the gear wheel icon (⚙️) in the bottom right of the **View Controls** .

In the example above, the structure is shown in 2D Cross section view in the Visualization area and, when opening the **Visualization Settings** dialog, the **Mode** is automatically selected as **2D** and all parameters concerning the display are listed in the panel.

This feature simplifies changing the values of these parameters, as it is not necessary to search for them in the menu bar or in the **View Controls** .

Tooltips guide the user through the parameters of the **Visualization Settings** dialog.

All settings changed in the **Visualization Settings** dialog are applied directly if **Apply Immediately** is checked. When the checkbox is disabled, the **Apply** button becomes clickable to apply the changes only when the user decides to do it.

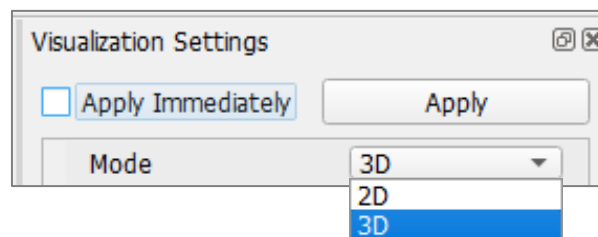

The selection of the **Mode** to be **2D** or **3D** affects the choices of settings for these two ways of rendering.

On the bottom of the **Visualization Settings** dialog, a group of icons controls the following in regard to visualization. Resting the mouse pointer over an icon prompts a tooltip showing the icon function to appear. For example, through them, it is easy to save all the current view settings and reload them:



Undo

Undos the last change in the view settings.



Redo

Redos the last undo.



Save current View Status to file.

Saves the current view settings to a GeoDict Python file (*.py).



Load View Status from file.

Loads view settings from a GeoPy (*.py) file.



Load built-in default View Status.

Resets all view settings to the built-in default settings.



Load start-up View Status.

Resets all view settings to the saved start-up settings.



Set current View Status as start-up settings.

Saves the current view settings as start-up settings.



Record the current View Status in the active macro recording and the session macro

Records the current view settings in the session macro. If a macro is recording, the current view settings are also recorded to the macro.



Sync with other GeoDict
Press this Button on two GeoDicts on the same Computer to synchronize the View Status.

Synchronize the visualization settings of two GeoDict instances on the same Computer to compare structures and volume fields.



Show All Options
If this is checked all possible view options are shown.
If this is not checked only view options that affect the current visualization are shown.

Shows all visualization settings. If not selected, only the view settings affecting the current visualization are shown.

Additionally, many view settings can be saved partially as **Start-up Settings** by clicking on the corresponding icon  next to the setting parameter.

Right-clicking on the labels opens a dialog offering the following options:

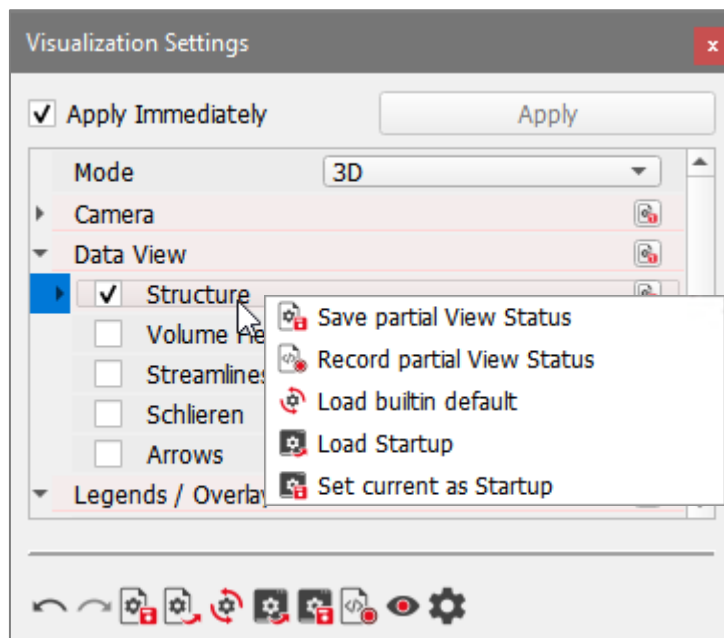

- **Save partial View Status** saves all settings corresponding to the selected section in a GeoPy macro (*.py) and can be applied whenever needed by selecting **Macro Execute Macro / Script** from the menu bar. To learn more about how to record, execute and edit macros refer to the [GeoPy scripting handbook](#) of the User Guide.
- **Record partial View Status** records the settings corresponding to the selected section to the macro currently recording. When no macro is recorded, nothing happens when selecting this option.
- **Load built-in default** loads the built-in default values only for the selected section.
- **Load Startup** loads previously saved custom start-up settings for the selected section. If no custom start-up settings were saved, the built-in default values are loaded.
- Use **Set current as Startup** to set the current settings as start-up settings for the selected section.

SETTING VISUALIZATION OPTIONS FOR DATA DISPLAY

When the image of a structure or a result (volume) field is displayed in the Visualization area, many preferences and options can be toggled and adjusted in the **View Controls**, under the **View** menu, and in the **Visualization tab** in the GUI **Sidebar** to complement and enhance the images' visual information. The access to several of the visualization options is redundant, meaning that they can be controlled from these three locations, for the user's convenience.

The default display, after starting **GeoDict**, is 2D Cross Section (SEM) view. The 2D view can be obtained at any time by clicking the 2D icon in the toolbar or selecting the 2D mode in the **Visualization Settings** dialog.

Different tabs appear in the **View Controls** depending on the current view mode (2D Cross Section SEM or 3D Rendering), as explained above in pages [14ff](#). These tabs are grayed out or selectable depending on the data associated with the image. The content in these tabs is reflected in the **Visualization Settings** dialog (Sidebar → Visualization tab → Visualization Settings dialog).

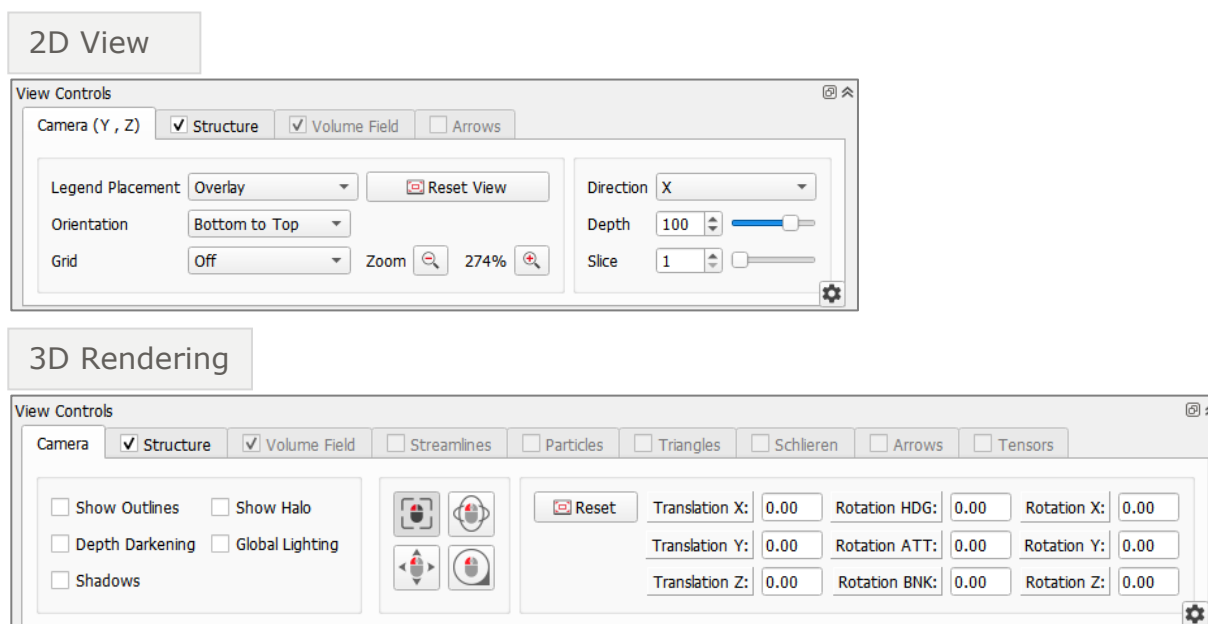

The next graphical examples (below) explain how to set visualization options through the tabs in the **View Controls** and in the trees of the **Visualization Settings** dialog.

All parameters under the **View** menu of the menu bar are integrated in the **Visualization Settings** dialog.

For this, in this Visualization handbook, the images shown in the Visualization area are the geometry data of a fiber structure generated with **FiberGeo** or the volume field from representative result files obtained from thermal conductivity computations with **ConductoDict**, from flow simulations with **FlowDict**, and from a simulation of particle filtration with **FilterDict-Media**.

Simulations run on a microstructure with the property predictor modules of **GeoDict** produce result files (.gdr). The results in the files are numerical in nature and can be directly analyzed and plotted. For many of the predictor modules, a portion of the results are saved into files for visualization in 2D view and 3D rendering as property images. For more information on result files, refer to the [Result Viewer](#) handbook of the User Guide.

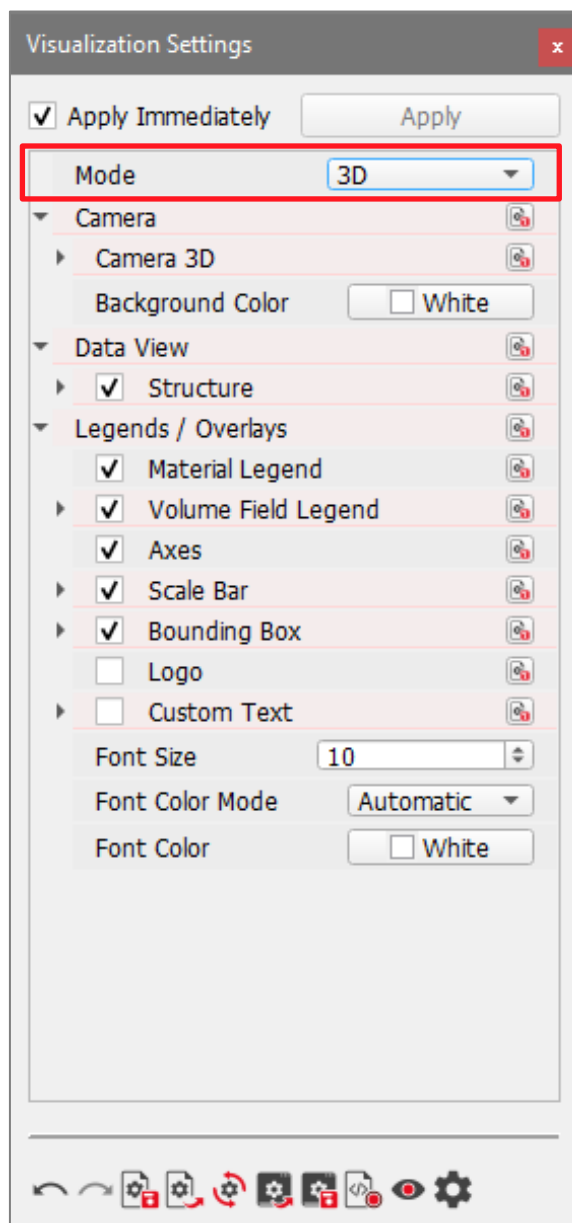
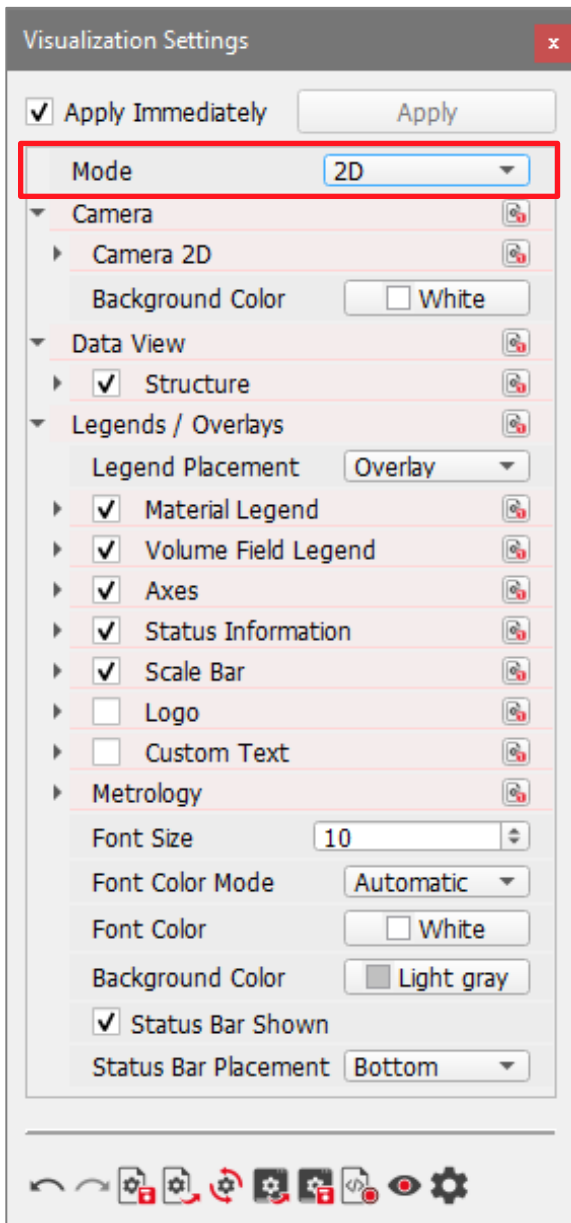

SETTING VISUALIZATION OPTIONS FOR 2D CROSS SECTION VIEW

Four tabs are present to control the 2D view settings: **Camera**, **Structure**, **Volume Field**, and **Arrows**.

The greyed-out Volume Field tab and Arrows tab correspond to the visualization of property data from result files and are explained starting on page [30](#).

The **Structure** tab is always selectable and checked by default when a structure is loaded. The settings in the Structure tab are explained starting on page [27](#).

CAMERA

Under the **Camera** tab of the **View Controls**, the user can choose which part of the structure is to be shown in the Visualization area. Here, with the initial default of Direction X, the tab is **Camera (Y, Z)**.

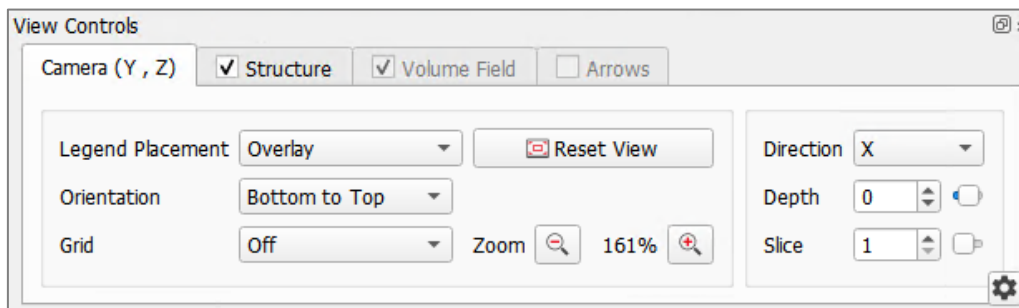

Two visualization options are available for the **Legend Placement**. If **Overlay** is selected, the legends are displayed above the 2D image, while for **Attached** the legends are placed around the image.

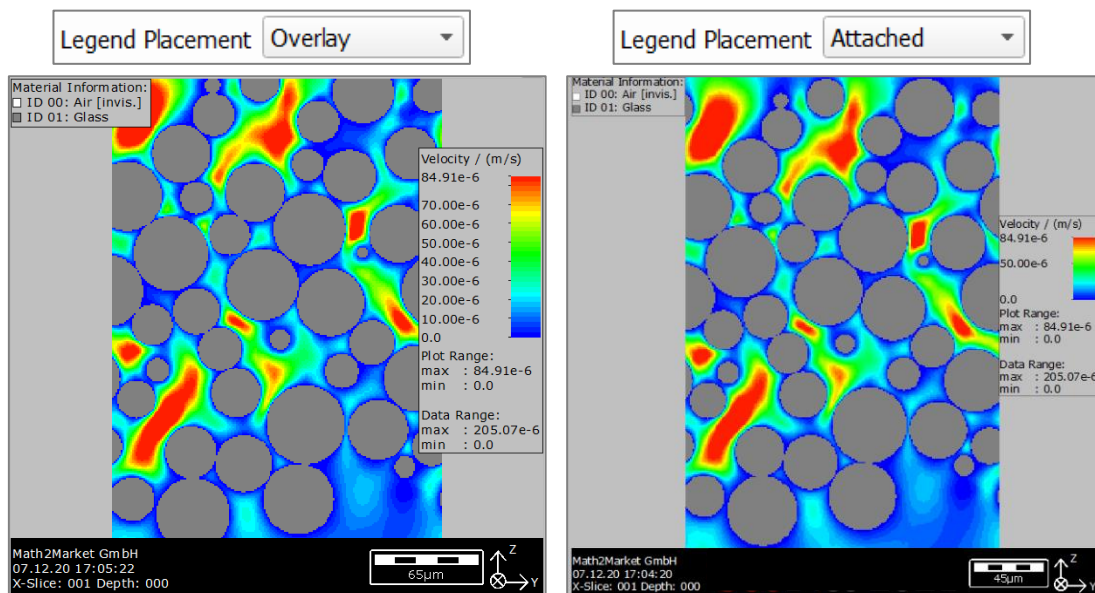

Direction X, Y, or Z, selectable through the pull/down menu, are the directions to which the cutting plane is perpendicular.

For example, choosing **X-Direction** slices the structure along the X-axis and shows images in the YZ-plane. The **Slice** slider controls the display of the cross-section in the selected cutting plane. The slice can be changed by moving the slider, by entering the slice number, or through the up and down arrows.

The **Depth** slider controls the slice view profundity when visualizing in 2D cross section mode. This allows to visualize images very similar to those produced by **Scanning Electron Microscopy (SEM)**.

The maximal **Depth** value is given (and can be changed) by the **Decay** value (see page 18 for the **Visualization Settings** dialog: **Camera** → **Camera 2D** → **Decay**)

The results of changing the depth are most noticeable in black and white view (**Color & Visibility tab** from the sidebar → **Load Preset** button → **Black & White**).

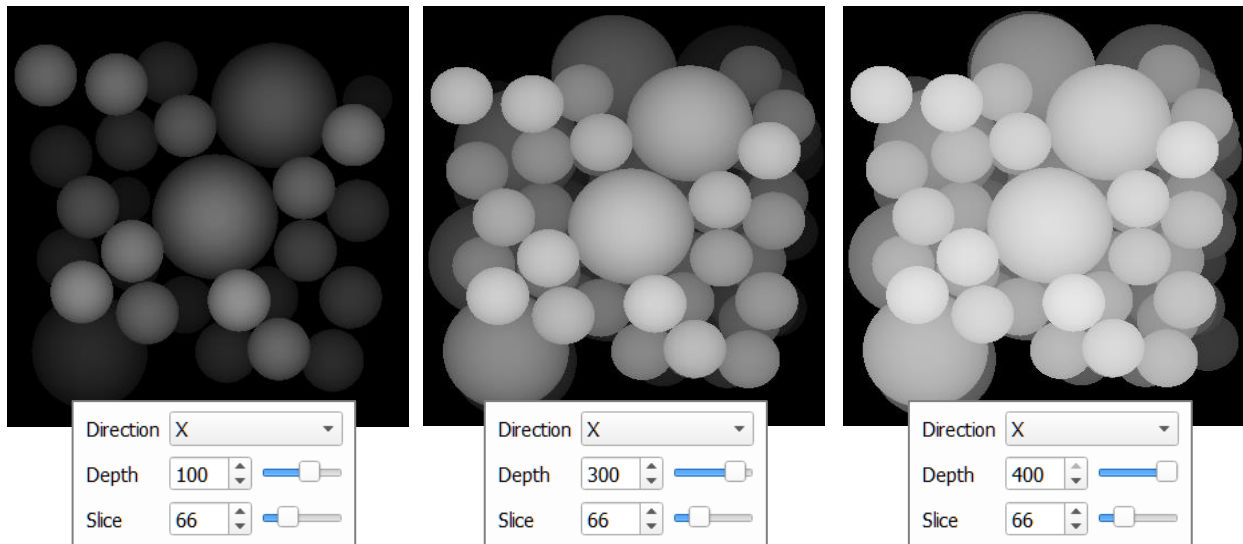

Change the image's **Orientation** by switching between **Bottom to Top** and **Top to Bottom**.

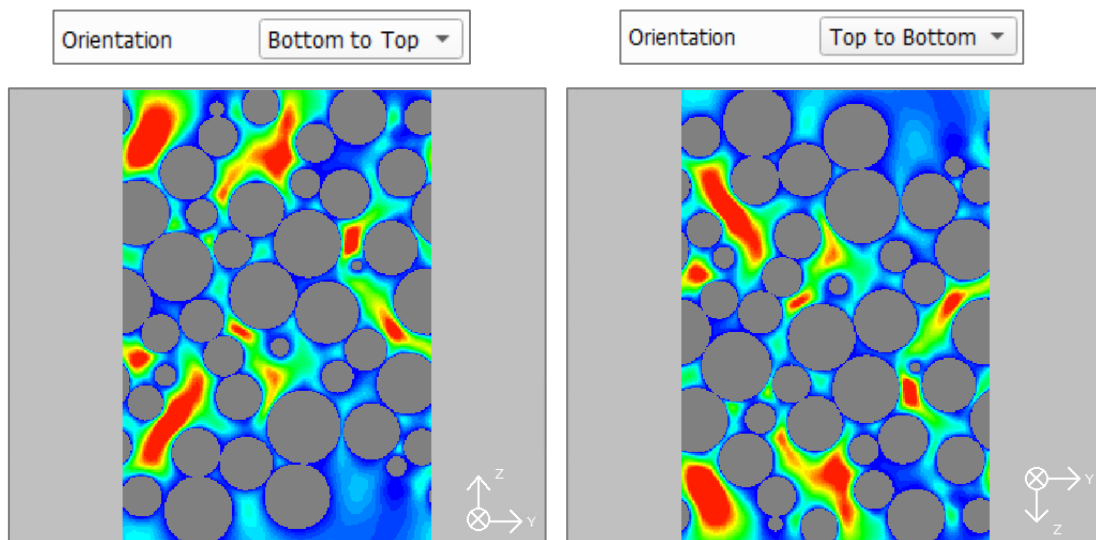

By default, the **Grid** is set **Off**. Enable the grid by selecting one of the other three options: **Regular Grid**, **Adaptive Grid** and **Structure Outlines**.

If a compressed flow field computed with the LIR solver is loaded, the **Adaptive Grid** is visualized when the user unchecks **Decompress fields** while loading the volume field. (A compressed field is saved when checking **Write Compressed Volume Fields** under the Solver tab of the **LIR Solver Options** dialog).

Unchecking **Decompress fields** to observe the **Adaptive Grid** has the effect of disabling some visualization features.

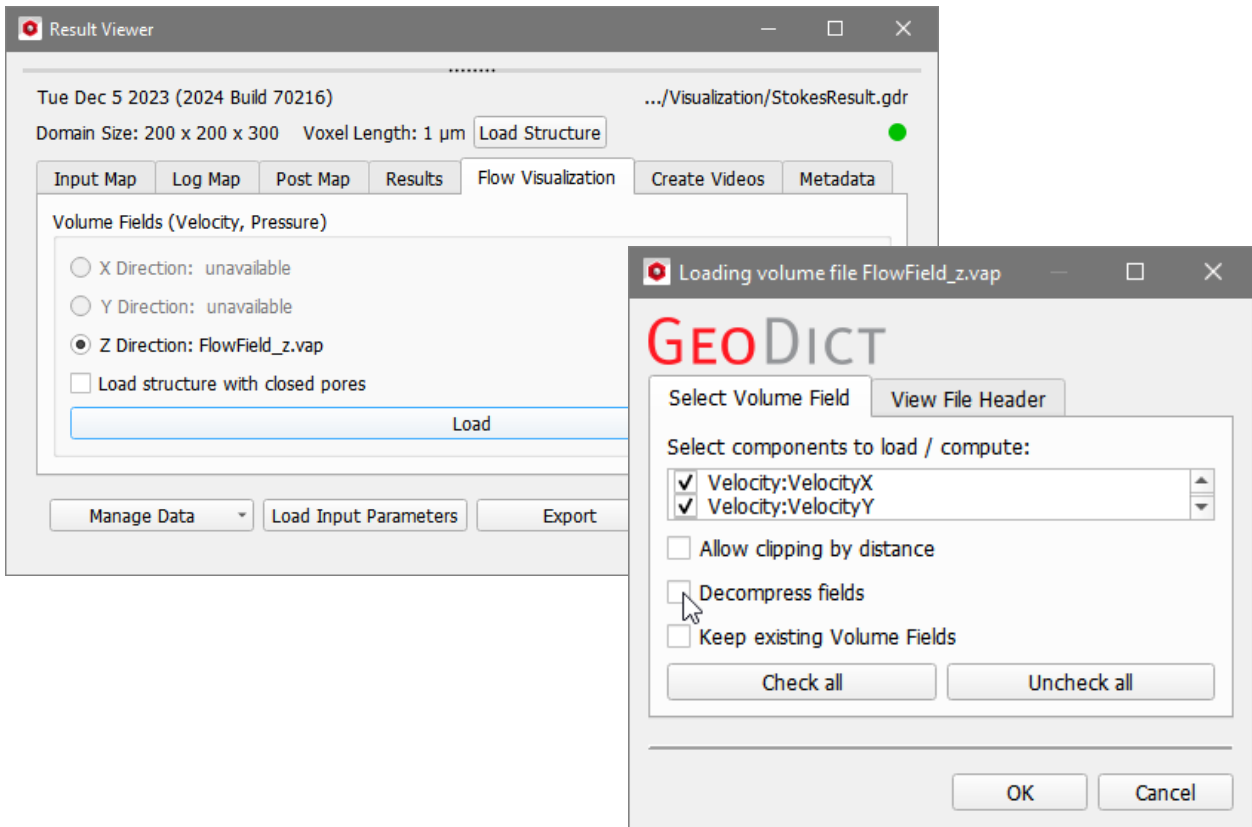

Then, select **Adaptive Grid**, as the **Grid** to be shown, under the **Camera** tab in the **View Controls**. Observe the small grid cells displayed near the pore-solid interface and the large grid cells in the center of big pores. Select **Structure Outlines** to display the outlines of the structure.

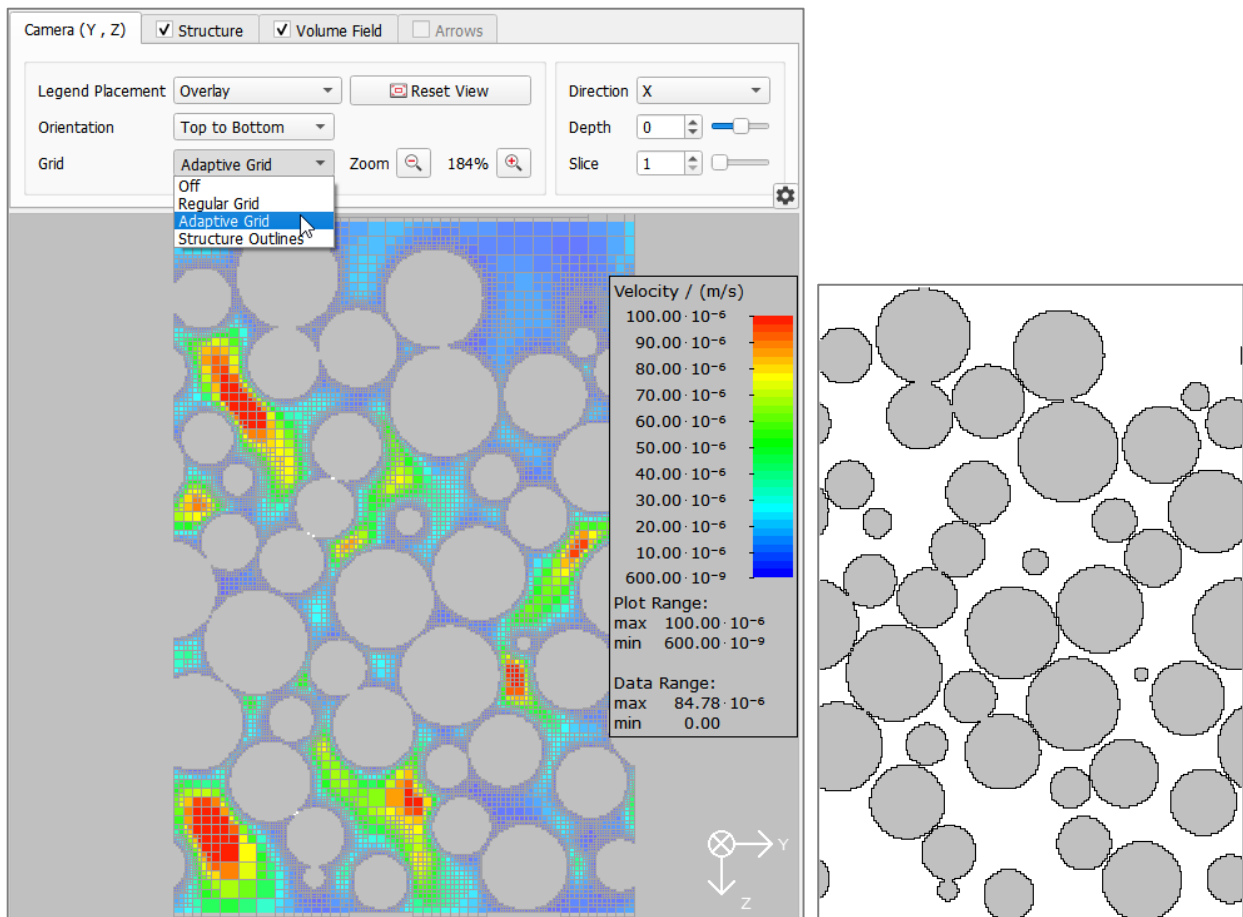

STRUCTURES - GEOMETRY DATA

A fiber structure generated with the **FiberGeo** module of **GeoDict** is used here to explain the visualization settings.

The **Structure** tab is always selectable (when a structure is loaded) and it is checked by default.

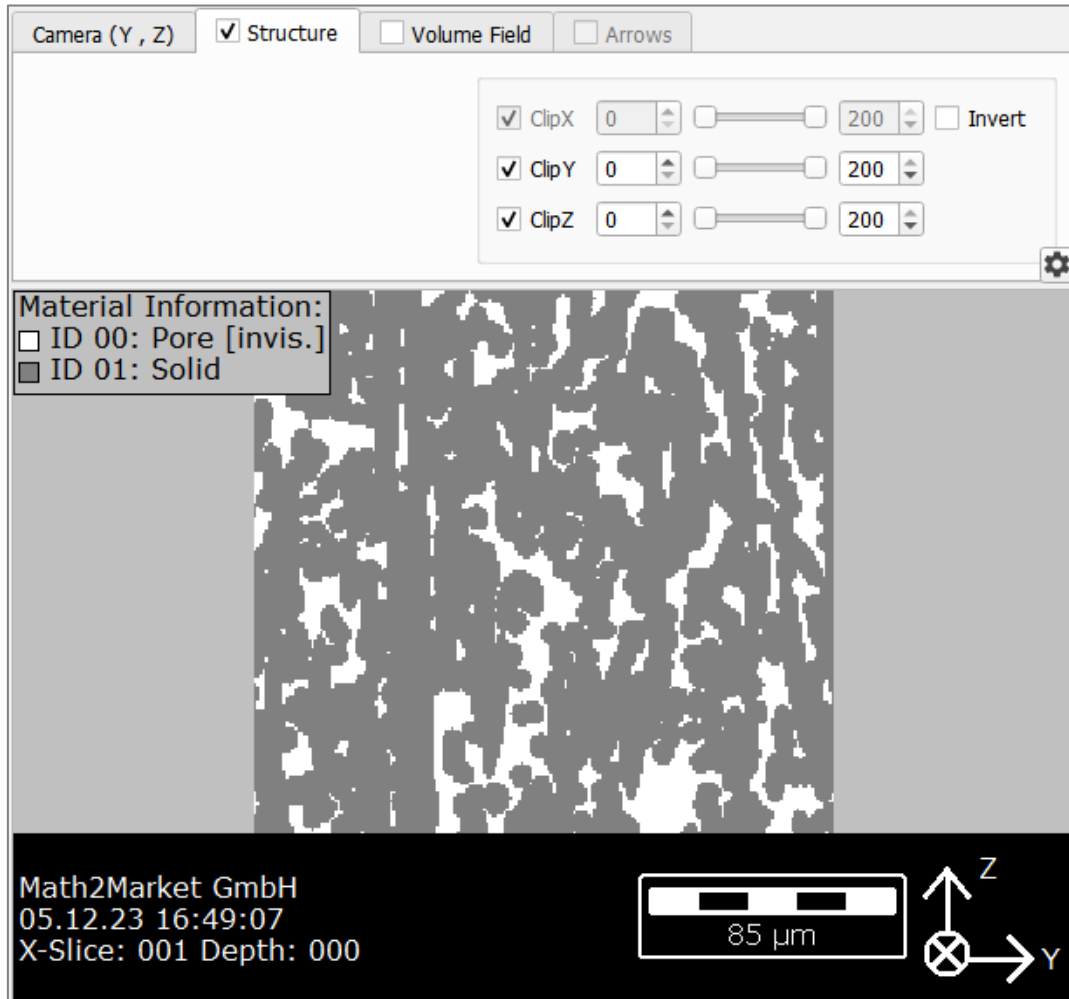

By unchecking the **Structure** tab, the structure disappears from the Visualization area because the display is disabled. Only the **Material Legend**, a white rectangle showing the domain, and the **Status Bar** remain visible.

The same effect is achieved by unchecking **Structure** through the **View** menu or from the **Visualization** tab of the GUI **Sidebar** as described [below](#) for the 3D view.

In the **Structure** tab, **Clipping** of the values **ClipX**, **ClipY**, and **ClipZ** allows cutting the displayed geometry in two of the three spatial directions with the sliders or by direct input. The clipping values corresponding to the selected view direction are not available, and thus grayed out.

Additionally, after defining a clipping area with the sliders or direct input, the user can limit this as the area of interest by checking **Invert** in the **View Controls**. Only the area defined by the clipping values remains visible in the Visualization area.

In the following example, **X** was selected for **Direction** in the **Camera** tab. Thus, the clipping is done in Y- and Z-direction.

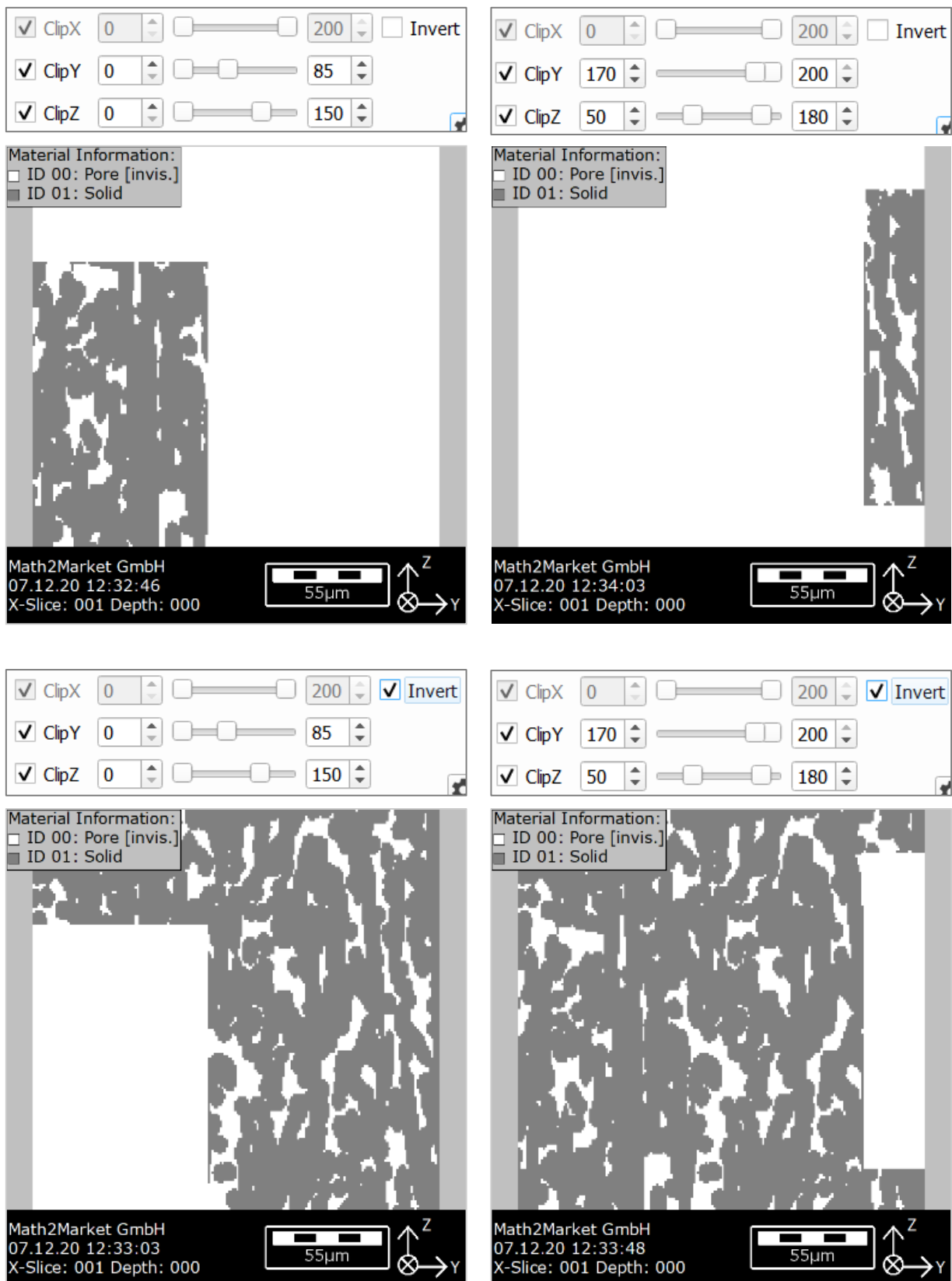

The **Structure** section in the **Visualization Settings** dialog allows to set the **Visibility** and the **Color** of the materials. They may also be defined in the **View Controls** and **Color & Visibility** panels.

Select **Use Database Colors** to visualize the materials in the colors saved in the **GeoDict** material database. The colors are also automatically changed according to the materials, if they are reassigned or a new structure is loaded or generated. For materials set to manual, the colors are not changed. To learn more about the database and how to set material colors, refer to the [Material Database](#) handbook of the User Guide.

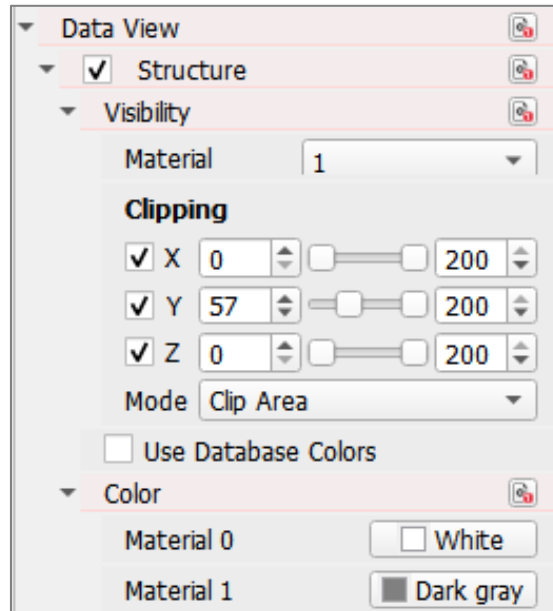

RESULT FIELDS – PROPERTY DATA FROM SIMULATIONS

Open a result file (*.gdr) by clicking the  icon in the toolbar and navigating to the location where a file, for example, obtained with **ConductoDict** is saved. Here, the file name is **EJHeatResult.gdr** and the example structure is a fiber structure as shown below.

The **Result Viewer** of the .gdr result file opens at the **Results – Report** tab.

Unless the structure is already in memory and showing in the Visualization area, click **Load Structure** to display it.

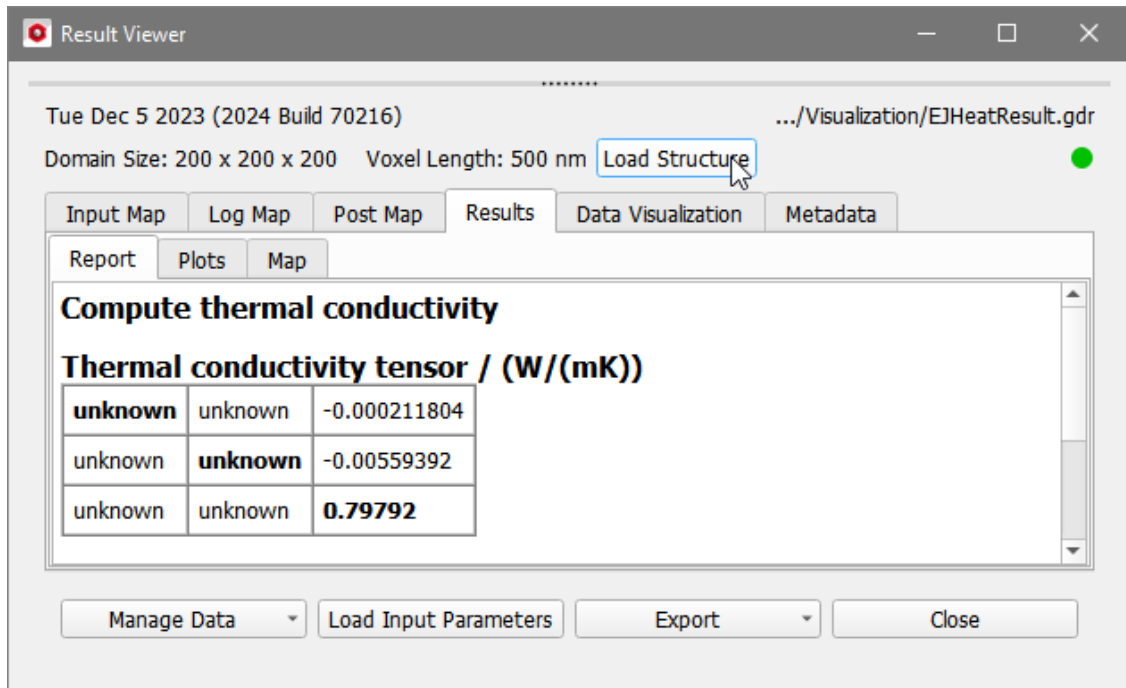

Observe the structure in 2D view in the Visualization area by selecting **View → 2D Cross Section (SEM)**.

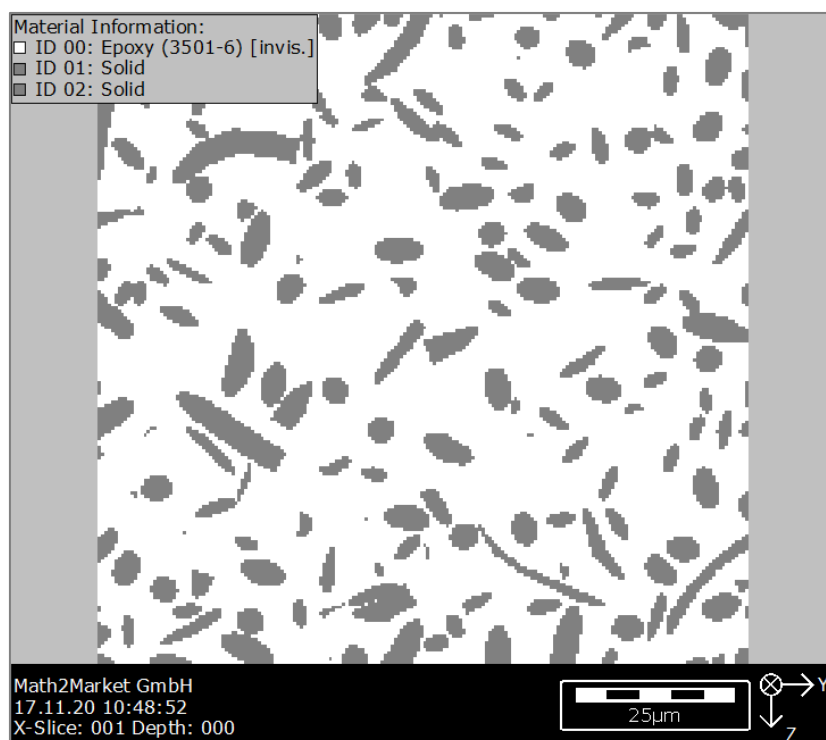

In the **Result Viewer**, click the **Data Visualization** tab.

Check the result field to load, here **VolumeField_z.hht**, and click **Load** to access the computed results in this case the results of temperature flux saved in the *.hht file. When loading a result field, additionally the corresponding structure is automatically loaded, if not already in memory.

The directions that were not selected are not computed, and, thus, are unavailable.

Then, choose the components whose results can be visualized.

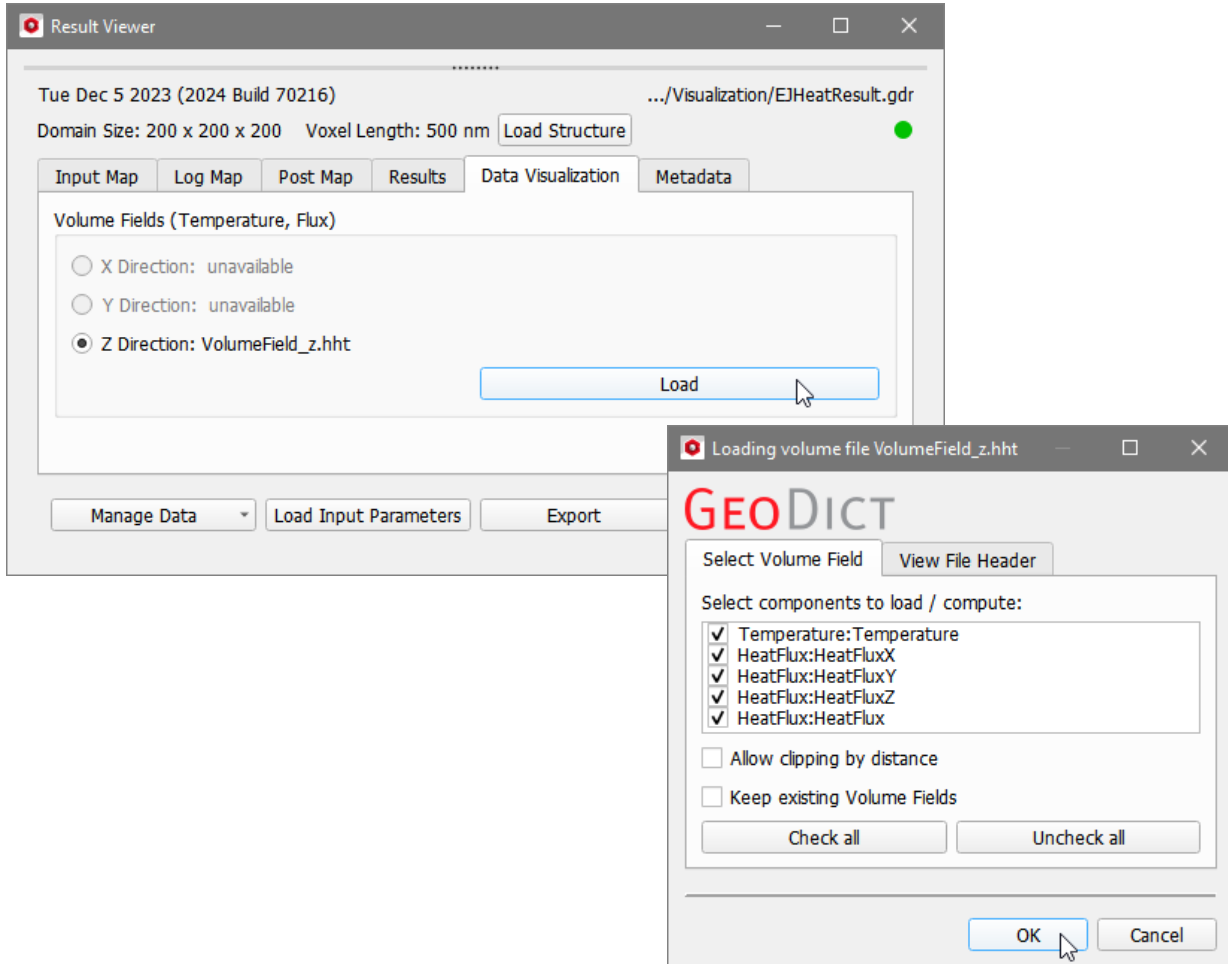

If the results are computed for the solid materials, as is the case in this example, the user is offered the choice to set the materials in the structure invisible. This is done to better observe the result field without the microstructure overlapping it. It is recommended to click **Yes**.

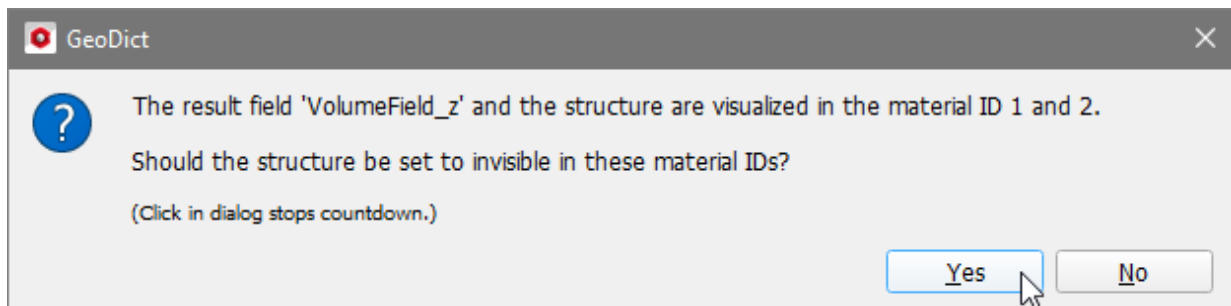

Now, the display in the Visualization area changes and the user can observe the information computed for the gradation of temperature. The values are indicated on the color bar of the **Volume Field Legend** that appears to the right (default position).

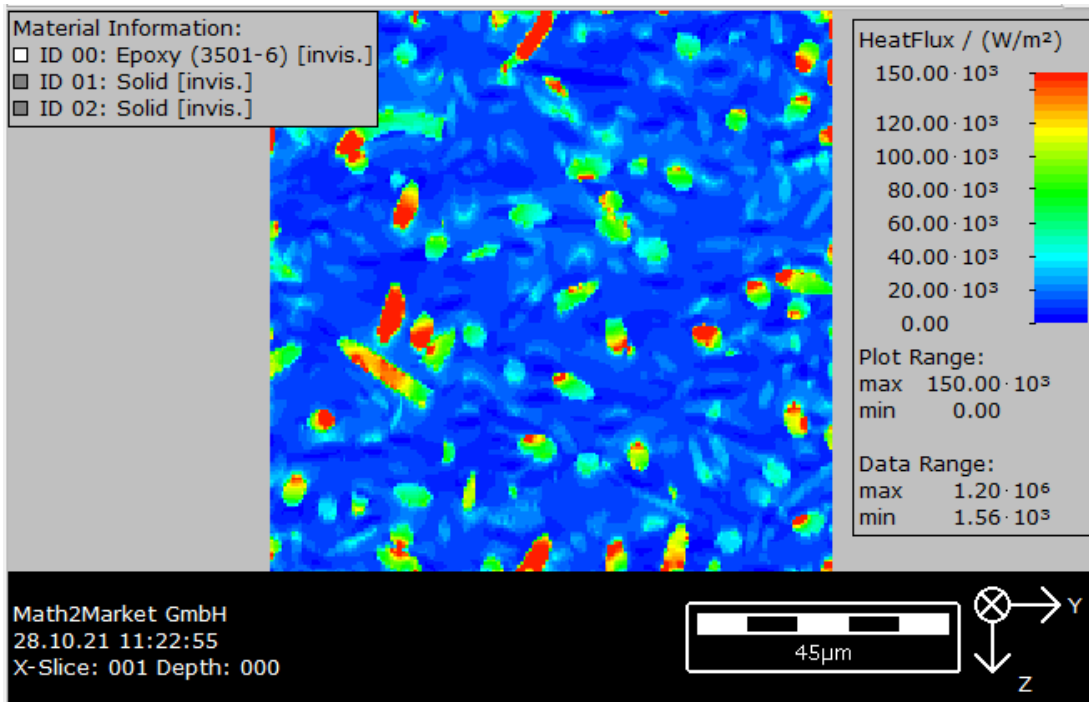

It may be useful to switch off the display of the Material Legend (**View** → **Legends / Overlays** → **Material Legend** in the menu bar or in the **GUI Sidebar**).

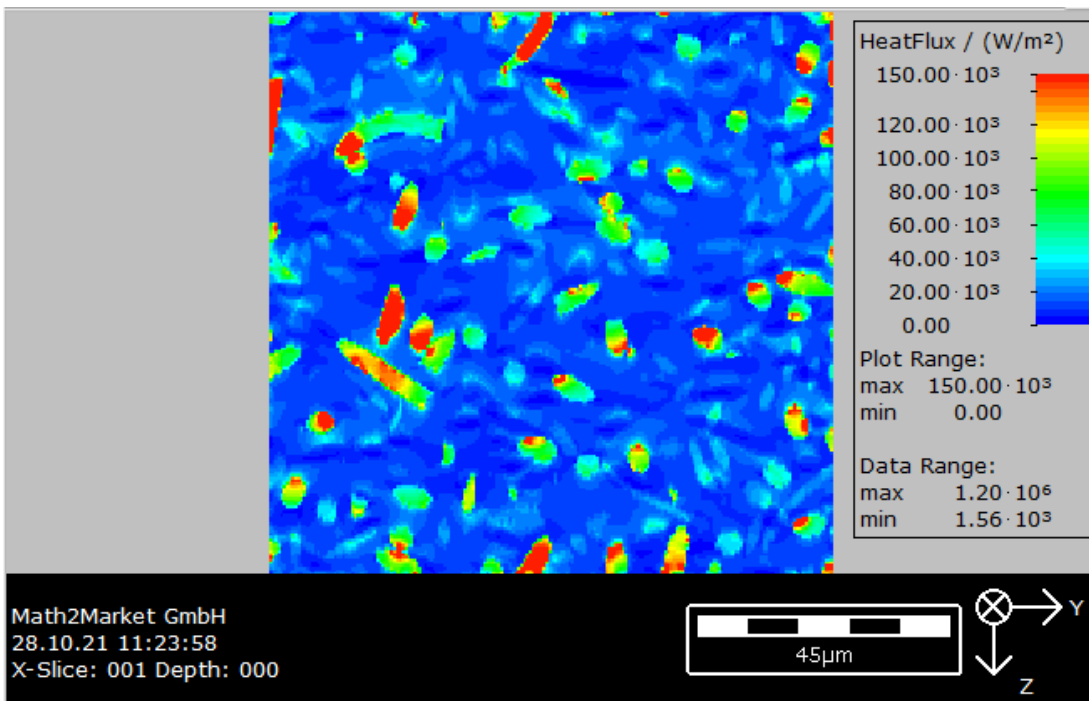

VISUALIZATION OF VOLUME FIELD

The parameters that control the visualization of the volume field in 2D are under the **Volume Field** tab of the **View Controls** and, with a few more choices, in the **GUI Sidebar** under the **Data View ▶ Volume Field** tree as well.

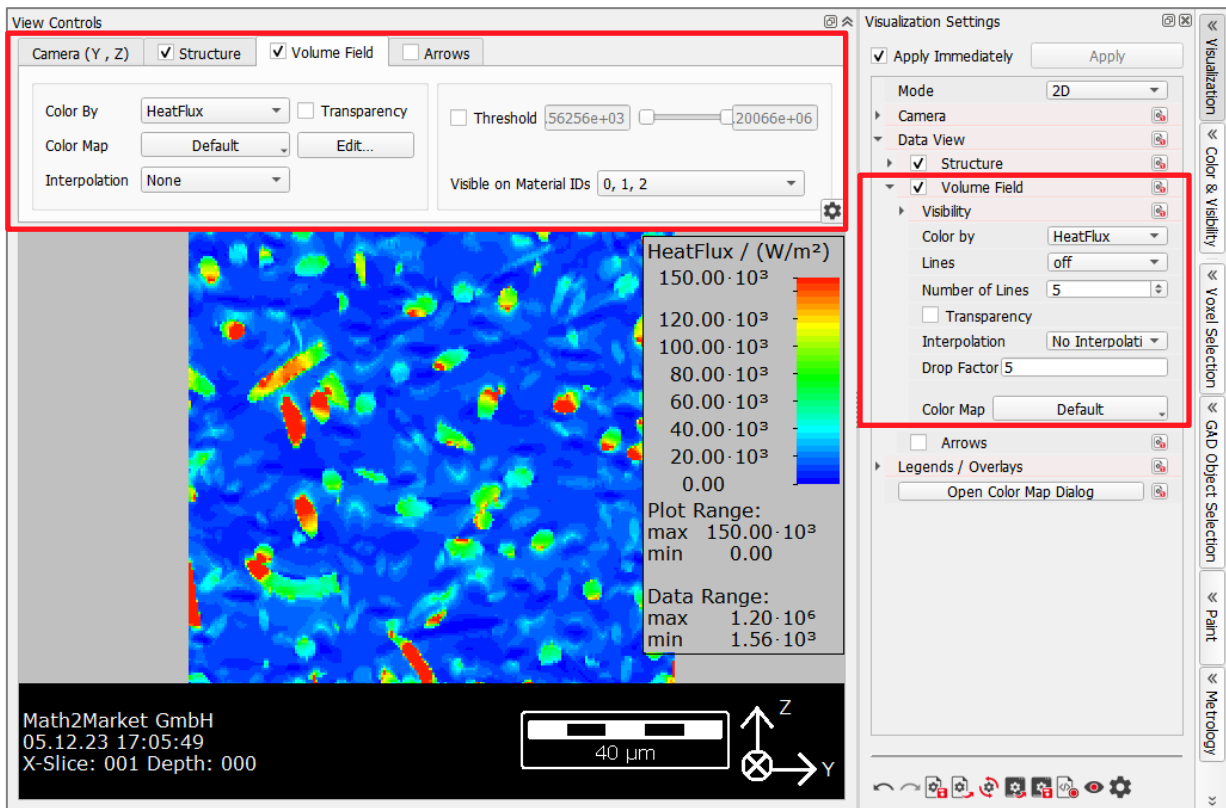

Among them is the choice of the component that is rendered in the 2D visualization, selected through the **Color By** pull down menu.

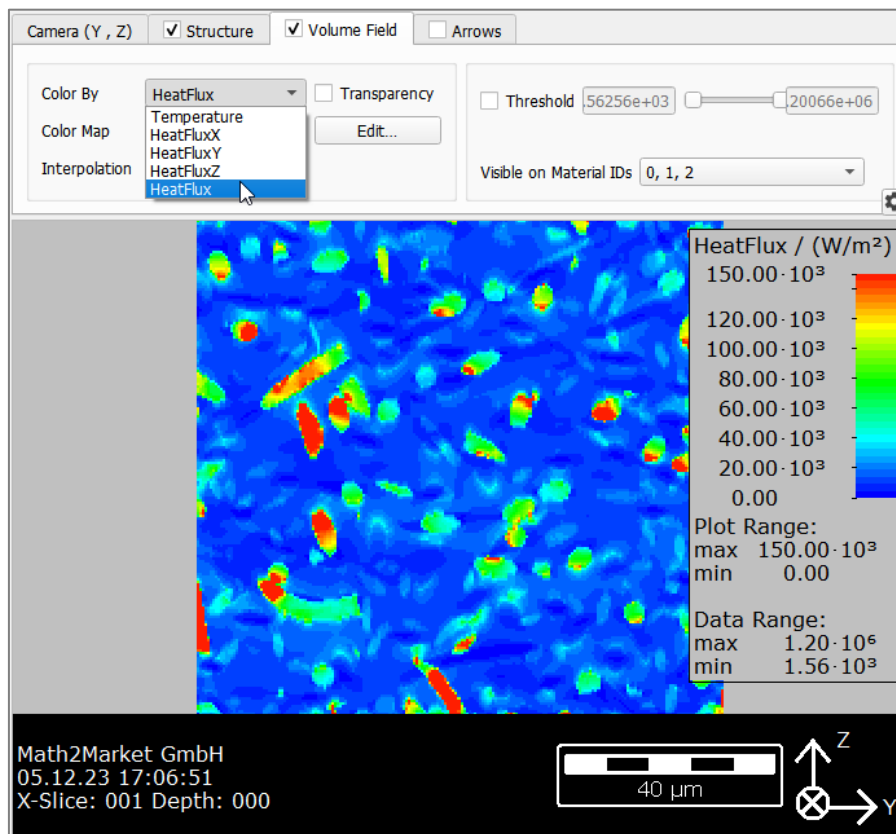

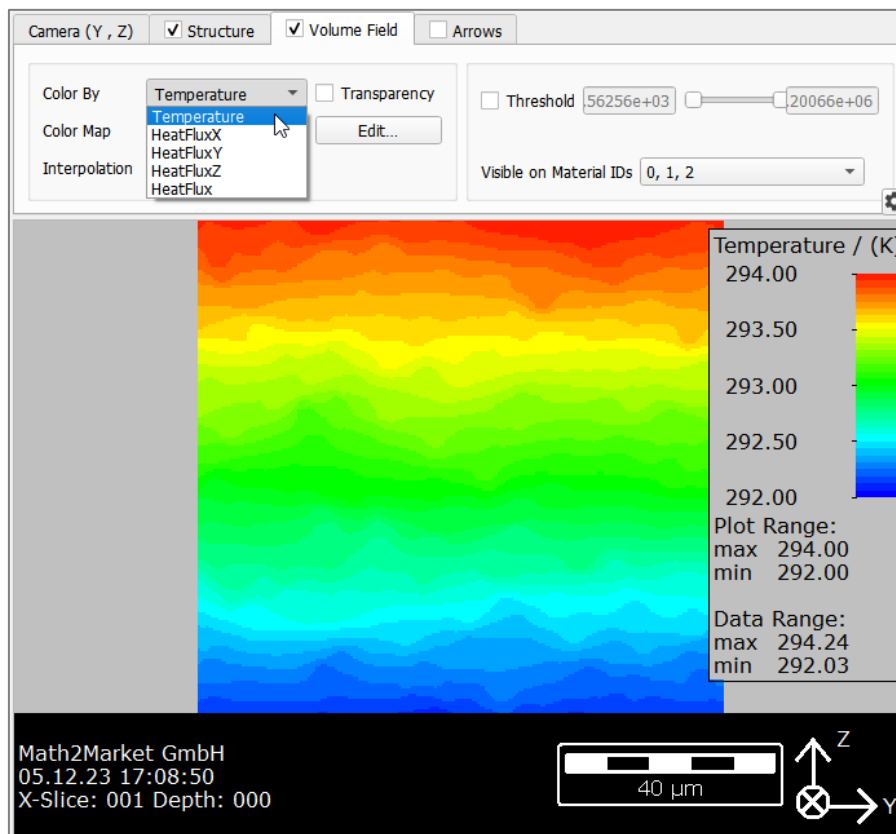

Clicking the **Edit...** button for **Color Map...** in the **Volume Field** tab, or **Open Color Map Dialog** in the **Visualization Settings** dialog, opens the **Color Map** dialog to fine-tune the visualization of results.

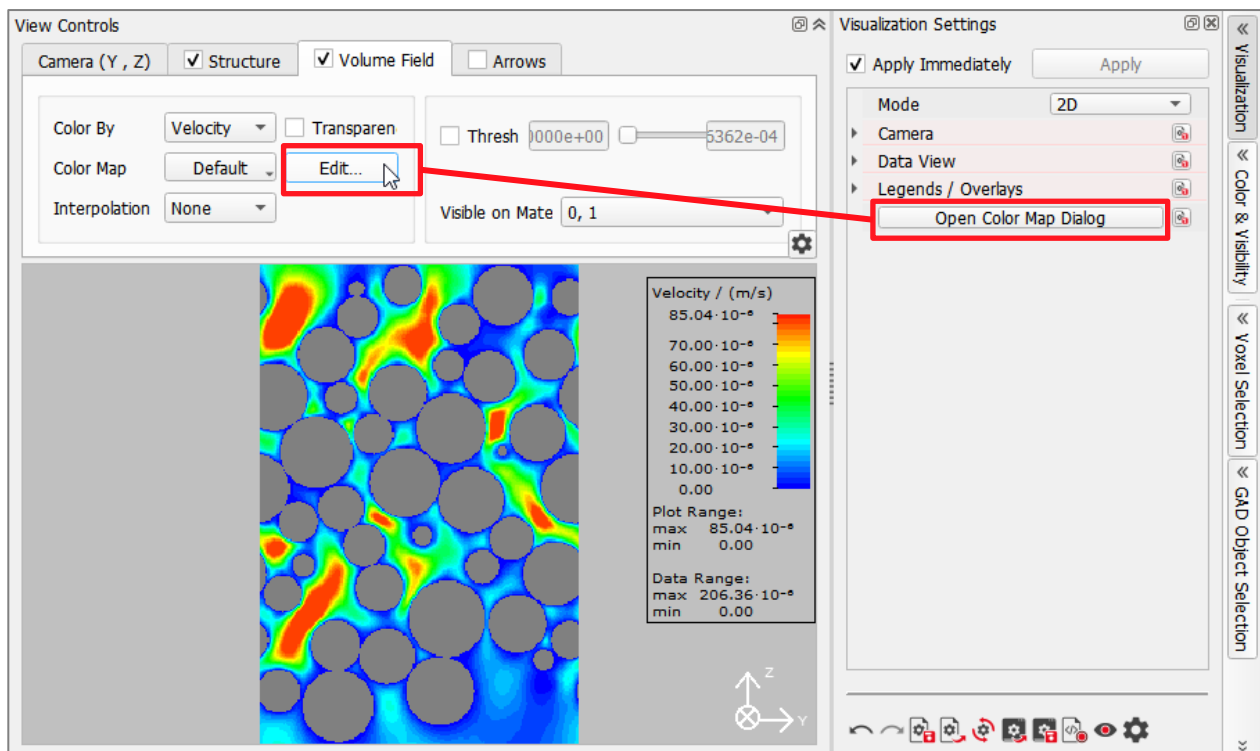

For example, if the **Data Range** is set to **Manual**, the point handles can be moved to quickly designate the upper and lower limits of the **Value Range (Low and High Threshold)** and apply **Transparency** to the visualized results. As usual, the values

entered in the **Color Map** dialog can be saved into *.gps (GeoDict Project Settings) files and/or loaded from them.

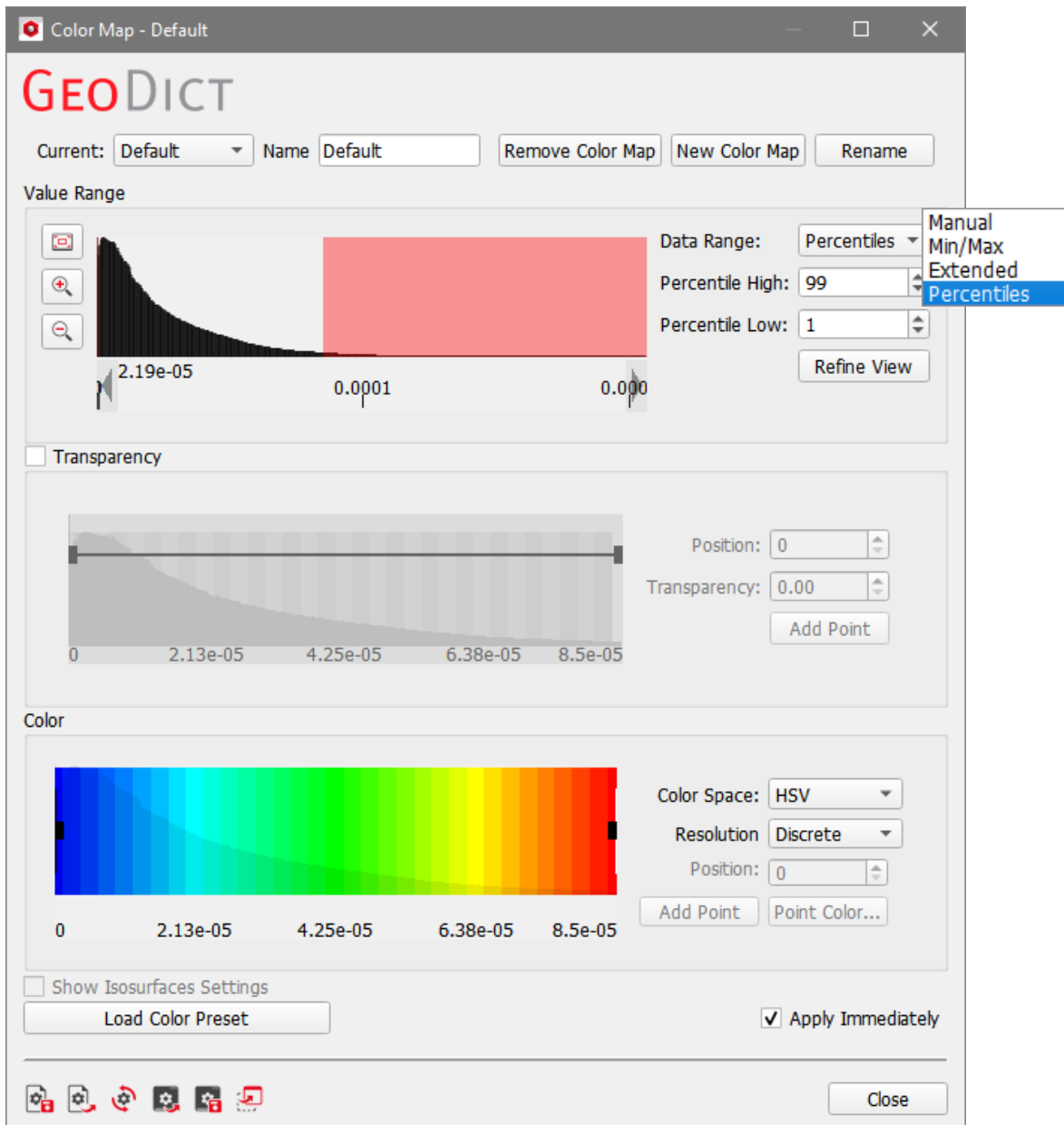

A color map is applied to the given data range. The data range can be selected in the following ways:

Manual – allows to enter minimum and maximum values directly.

Min/Max – the minimum and maximum values from the field are used.

Extended – the minimum and maximum values are chosen to be an easy-to-read number rounded to the extended range.

Percentiles - minimum and maximum values are computed from the field's histogram.

The histogram is displayed on the left and can be zoomed in and out with the **Zoom** icons. The view can be reset again with the corresponding icon. If **Manual** is selected for **Data Range**, the thresholds can also be set with the red squares in the histogram.

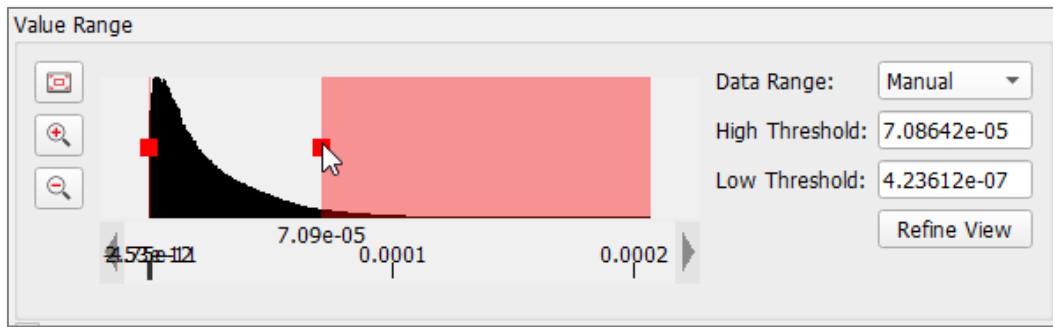

When zooming in deeply into the histogram, the resolution is not refined automatically, as it can take some time. Therefore, then click **Refine View**.

For flow simulation results obtained with the **FlowDict** module (see below), it is interesting to “see-through” the flow field and to emphasize the areas where the flow is fast.

Click **Transparency** in the **Color Map** dialog, and change the shape of the transparency curve by adding and moving new anchor points.

To add new points either left-click in the plot and click **Add Point** on the right or right-click in the plot and click **Add Point** there.

Move the points either by drag and drop or by entering the desired values for **Position** and **Opacity** for the selected point.

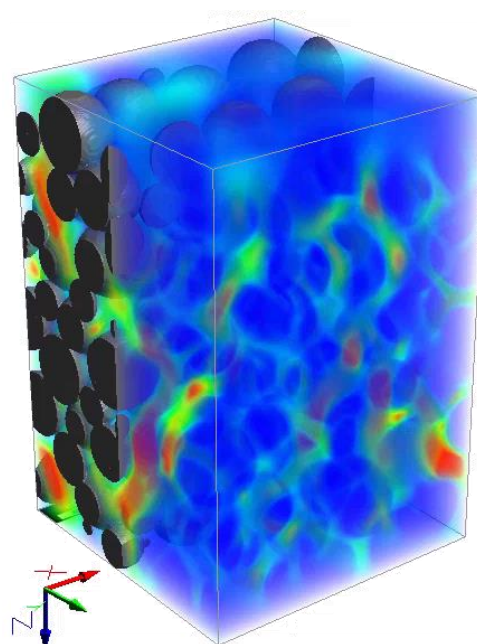
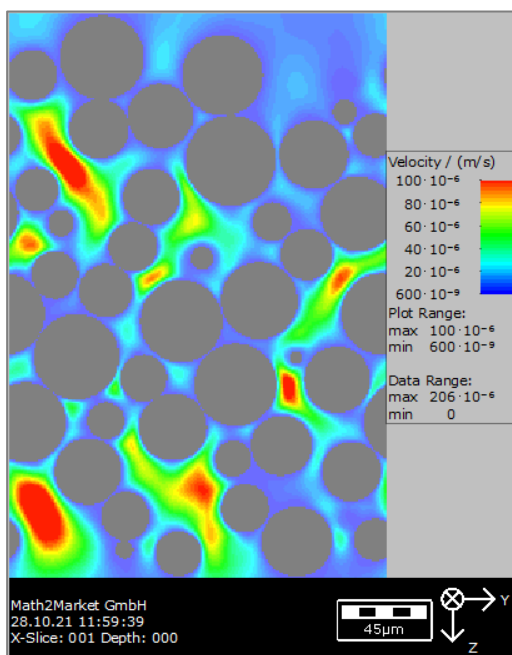
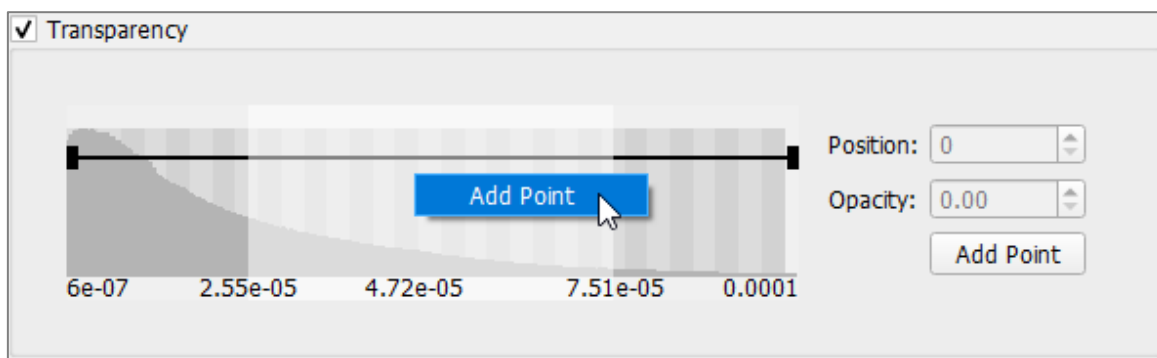

Observe the transparency gradient in the flow field with the following settings:

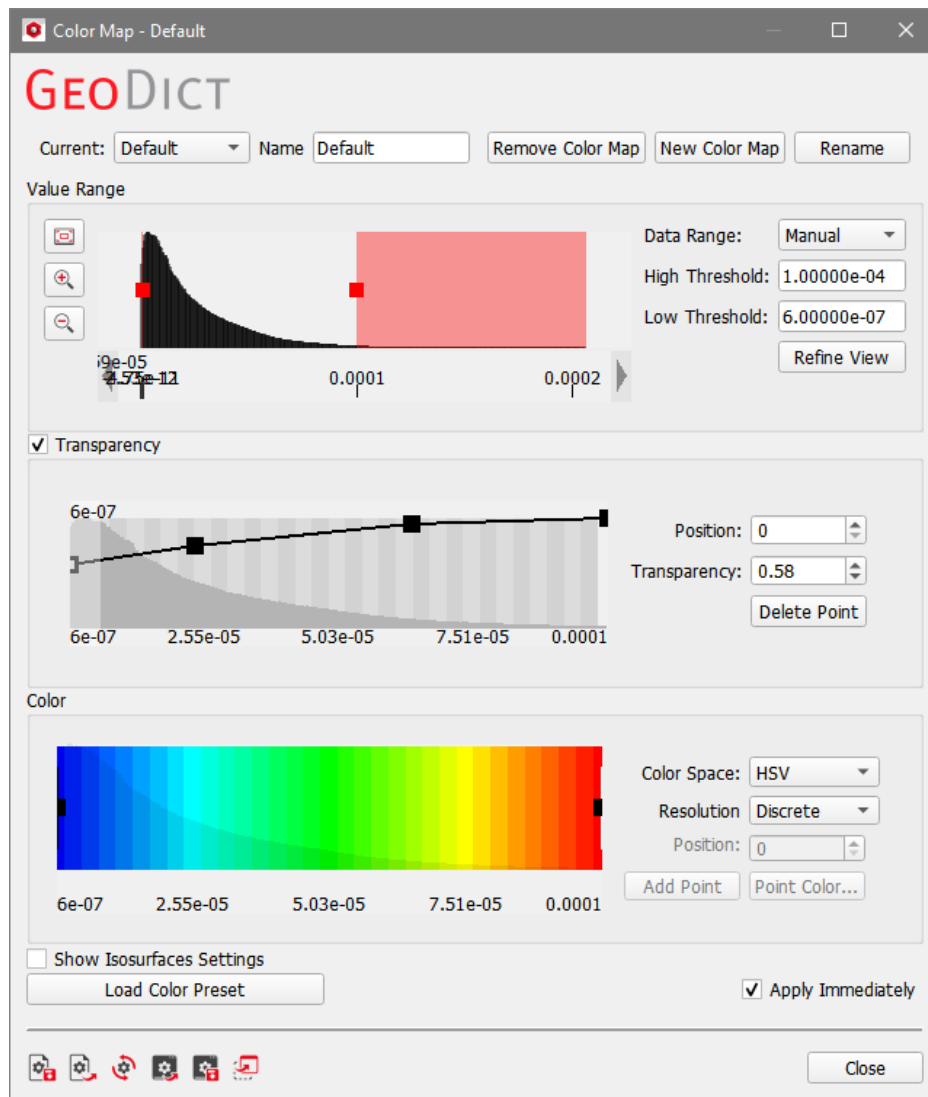

In the **Color** panel, the user controls the color gradient. Change the complete **Color Space**, by selecting a different option from the pull-down menu. The **Resolution** can be set to **Discrete** or **Continuous**. In the color graph points can be added by left- or right-click and selecting **Add Point**. The **Point Color** and **Position** can be changed on the right, creating a custom color space.

The **Isosurfaces** are only visualized in 3D rendering and are explained on page [64](#). The according settings are shown when checking **Show Isosurfaces Settings**.

If **Apply Immediately** at the bottom right of the dialog is checked, these choices are instantly used on the display in the Visualization area, while keeping the **Color Map** dialog open to make other changes. Otherwise, click **Apply** to change the visualization settings.

Click **Close** when the visualization fits your needs.

Create different color maps in the current session for the different result fields. To do so, in the **Color Map** dialog enter a **Name** and click **New Color Map** in the **Color Map** dialog or, in the **View Controls**, unfold the pull-down menu for **Color Map** and click **Add**.

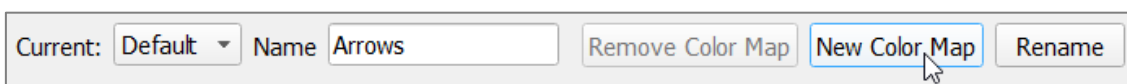

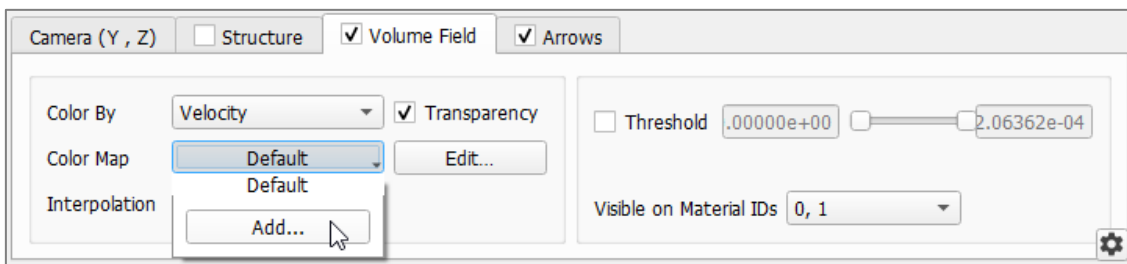

Edit the settings as desired, and switch between the current color maps by selecting the needed color map from the pull-down menu in the **Color Map** dialog, in the **View Controls** or thru the **Visualization Settings** dialog of the GUI **Sidebar**.

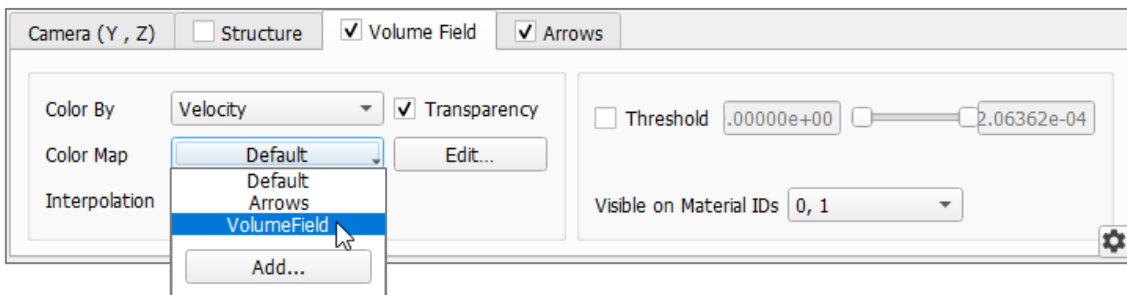

Having different color maps is very useful, if different result fields should be displayed in different color styles. In the **Visualization Settings** dialog, for each of the result fields under **Data View**, find the option to select a **Color Map** for the corresponding result field; here shown for the **Arrows**.

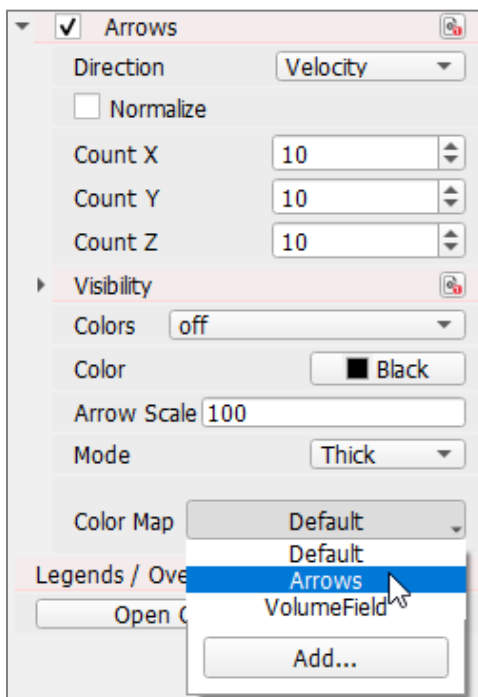

The **Color Map** dialog also offers the possibility to **Rename** or **Remove Color Maps**. Save all color maps for later use in other GeoDict sessions, in a *.gps file or as start-up settings with the corresponding buttons in the bottom of the **Color Map** dialog. Resting the mouse pointer over an icon prompts a ToolTip showing the icon's function.



In **2D mode** the volume field colors cannot be interpolated. Thus, only **None** is selectable from the pull-down menu for **Interpolation**. The different interpolation options for the 3D mode are described starting on page [65](#).

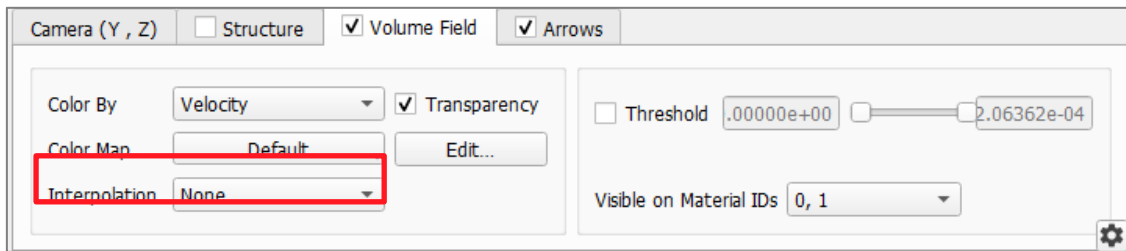

In the **View Controls** or the **Visualization Settings** dialog, choose the Material IDs in which the volume field is visualized. This helps in better observing a value of a computed component of the volume field. To do so, select these materials from the **Material ID's** pull-down menu.

By default, all Material IDs present in the structure are selected.

In the case shown here, the flow only happens in the material occupying the pore space (Material ID 00), since the fluid in the structure does not flow through the solids (here, Material ID 01). The flow velocity is displayed in the space occupied by Material ID 00. The flow velocity is not displayed when the Material ID 00 is disabled.

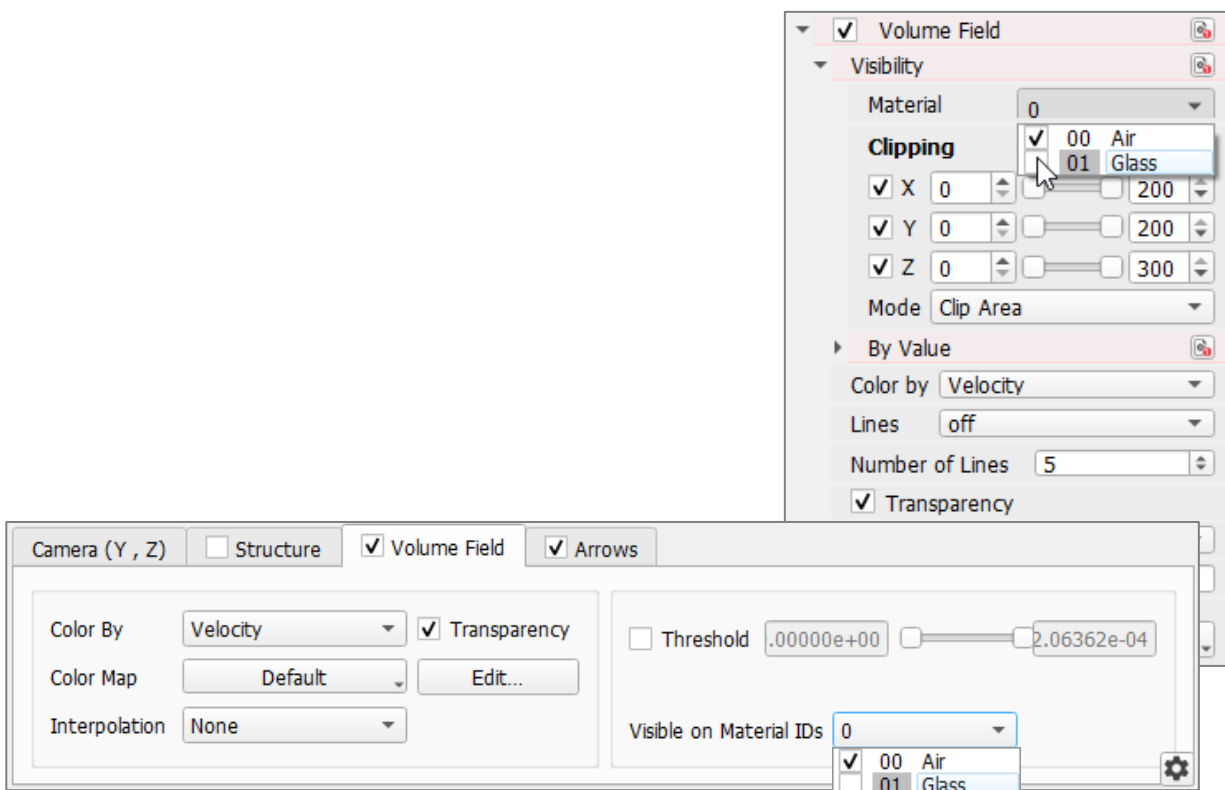

Points of equal value of the selected local field can be visualized as cross-sections of isolines (appearing as black lines) when changing the default selection **Lines** → **off** in the **Visualization Settings** dialog (**Data View** ► **Volume Field** ► **Lines**).

Choose the result field component for the lines. It is also possible to visualize for example the velocity colors, while visualizing the Pressure lines. This gives the possibility to look for correlations.

Enter the desired **Number of Lines** and modify the appearance of the lines through the value **Drop Factor**. Smaller values for **Drop Factor** result in larger line shadows, while higher values lead to smaller shadows.

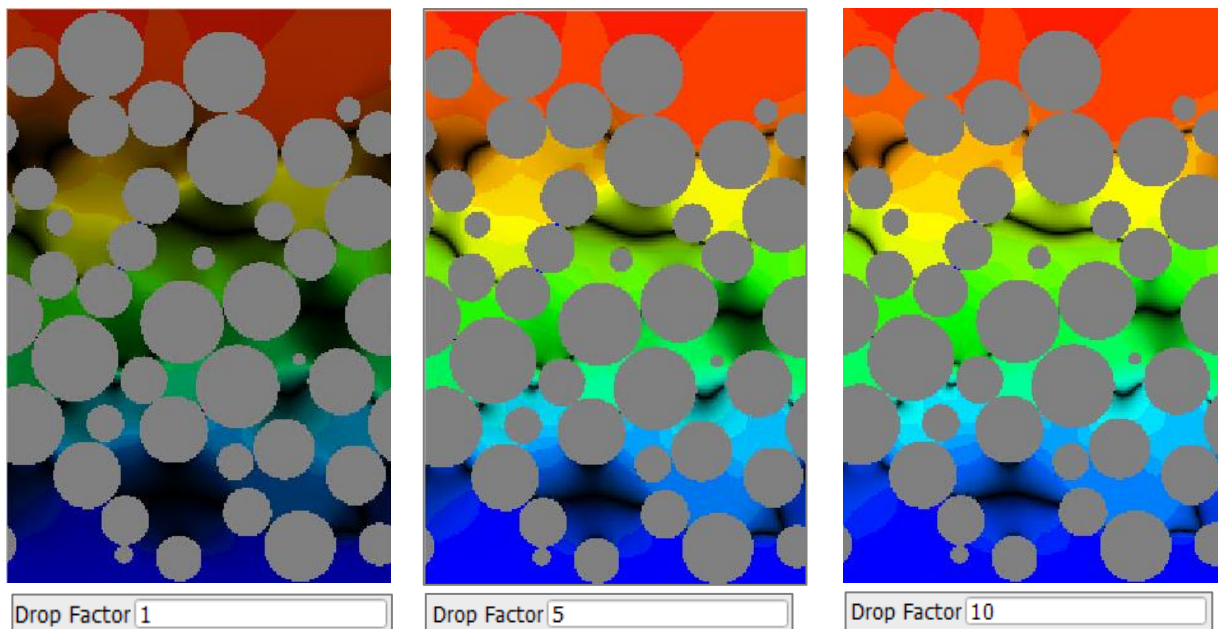
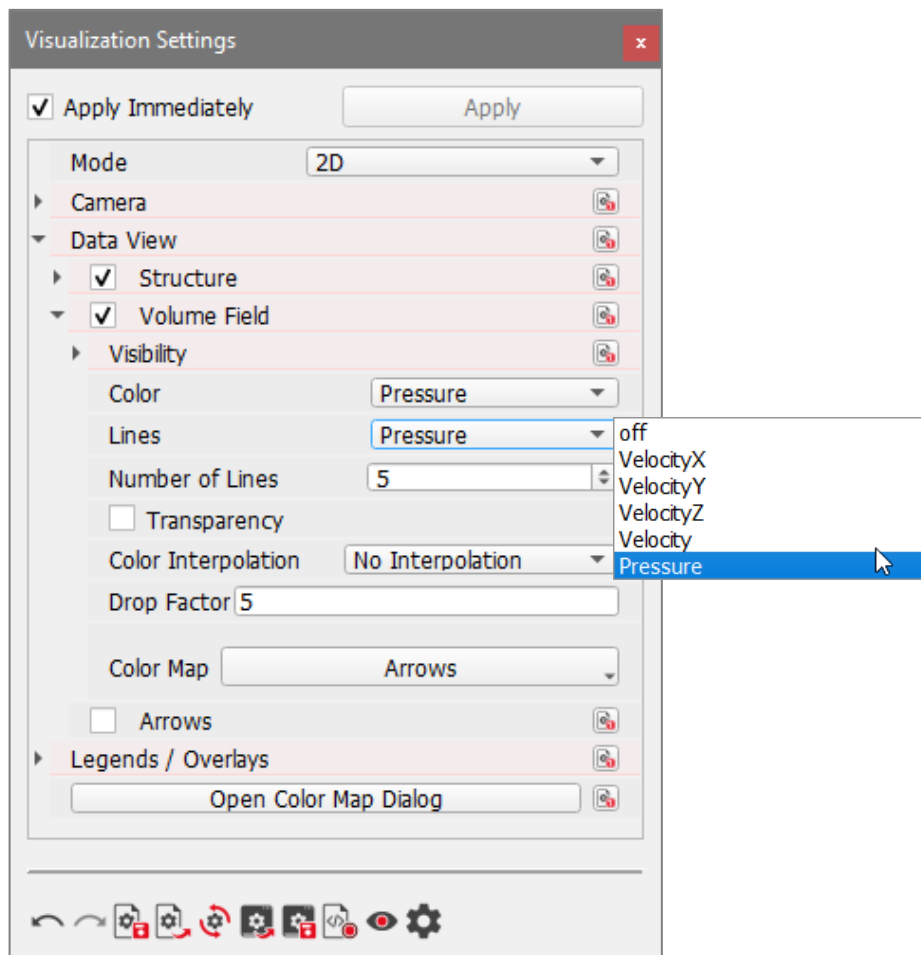

To the right side of the **Volume Field** tab, in the **View Controls** , checking **Threshold** allows a clipping that is not related to the spatial coordinates but to the visualized data range. The areas with values between the respective threshold values appear white/transparent. This might be used, for example, to visualize only the flow velocity values between 0.00006 ($6e^{-05}$) m/s and the maximum of 0.0002 ($2.05e^{-04}$) m/s. In the **Visualization Settings** dialog, find the option as **Visibility** → **By Value** → **Threshold**.

Setting visualization options for 2D Cross Section view

The image shows the software interface for setting visualization options for a 2D Cross Section view. The main window displays a velocity field around a porous medium, with a color scale for Velocity / (m/s) ranging from 0 to $90 \cdot 10^{-6}$. The plot range is max $90 \cdot 10^{-6}$ and min 0. The data range is max $206 \cdot 10^{-6}$ and min 0.

The 'Camera (Y, Z)' panel shows the following settings:

- Structure:
- Volume Field:
- Arrows:
- Color By: Velocity
- Transparency:
- Color Map: Default
- Interpolation: None
- Visible on Material IDs: 0
- Threshold: 6.00000e-05 (slider range 6.00000e-05 to 2.05000e-04)

The 'Visibility' panel shows the following settings:

- Material: 0
- Clipping:
 - X: 0 (slider range 0 to 200)
 - Y: 0 (slider range 0 to 200)
 - Z: 0 (slider range 0 to 300)
- Mode: Clip Area
- By Value:
 - Threshold:
 - Threshold 0: 6e-05
 - Threshold 1: 0.000205

VISUALIZATION OF ARROWS

Another flow field visualization option is representing the volume field by an arrow field.

Here, the properties of the fluid flow field are imaged at all positions of a regular grid that do not belong to the solid. At each of these positions, the local orientation of the flow field is indicated by a vector and its length and color are coded for the fluid velocity.

Small vectors indicate a slow fluid velocity and long vectors indicate a high fluid velocity. Vectors are located with their middle in the center of the voxel for which they represent the flow velocity.

To see the arrows, check only **View** → **Arrows** in the menu bar, the **Arrows** tab in the **View Controls**, or **Data View** ► **Arrows** in the **Visualization Settings** dialog.

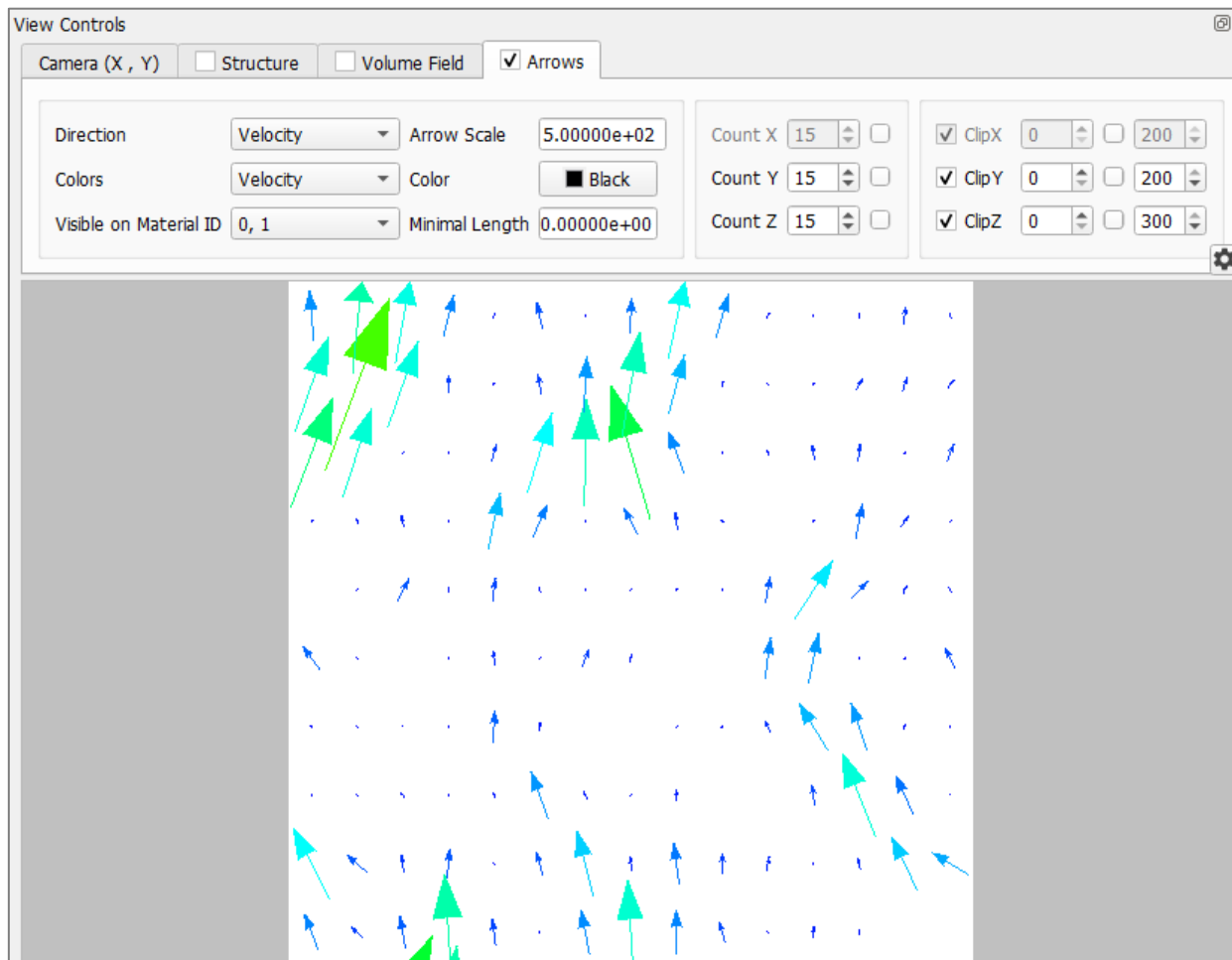

The options are the same as for the 3D visualization described starting on page [79](#).

SETTING VISUALIZATION OPTIONS FOR 3D RENDERING

A structure appears in the Visualization area after loading a file (*.gdt, *gad). Then, select **View** → **3D Rendering** in the menu bar or click  in the toolbar.

In the **View Controls**, above the structure displayed in 3D, up to nine tabs are selectable to control the 3D view settings: **Camera**, **Structure**, **Volume Field**, **Streamlines**, **Particles**, **Triangles**, **Schlieren**, **Arrows** and **Tensors**.

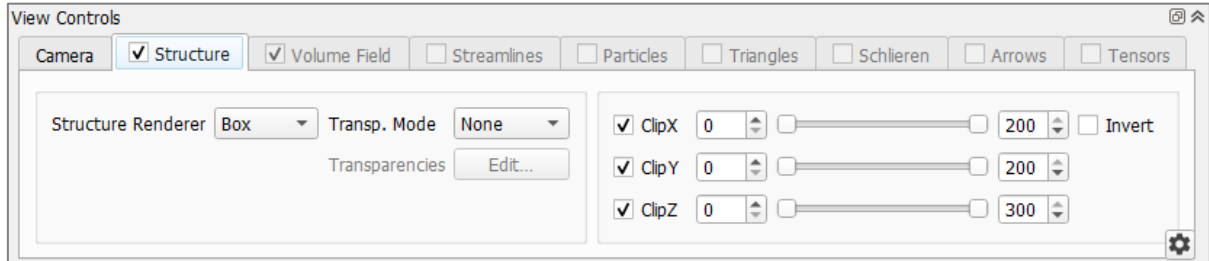

The grayed-out tabs correspond to the visualization of property data from result files and are explained starting on page [53](#).

Additionally, the **Structure** tab is always selectable (when a structure is loaded) and it is checked by default. The settings in the Structure tab are explained starting on page [47](#).

CAMERA

The **Camera** tab controls the light behavior, the camera angle from which the structure is viewed and the position of the structure in the Visualization area.

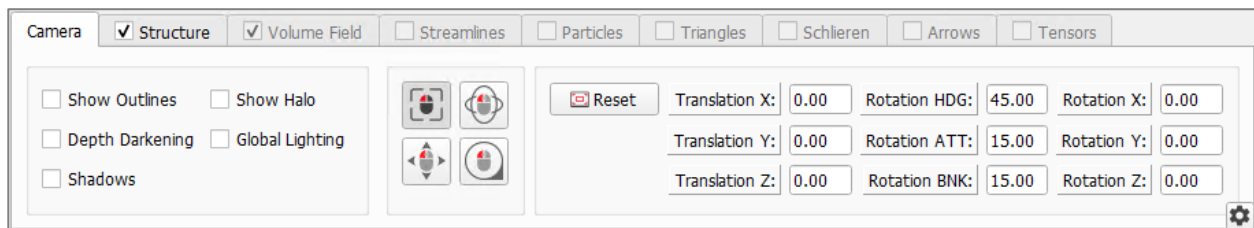

The check boxes improve the visual perception of the structure, as follows:

- Checking **Show Outlines** adds outlines around objects to emphasize the edges in the structure.
- **Depth Darkening** darkens areas according to their distance to the camera, resulting in a better depth perception.
- Checking **Show Halo** shows a subtle halo around objects.
- **Global Lighting** simulates a realistic light behavior but needs more hardware resources.
- Enable **Shadows** to cast shadows from opaque parts of the structure.

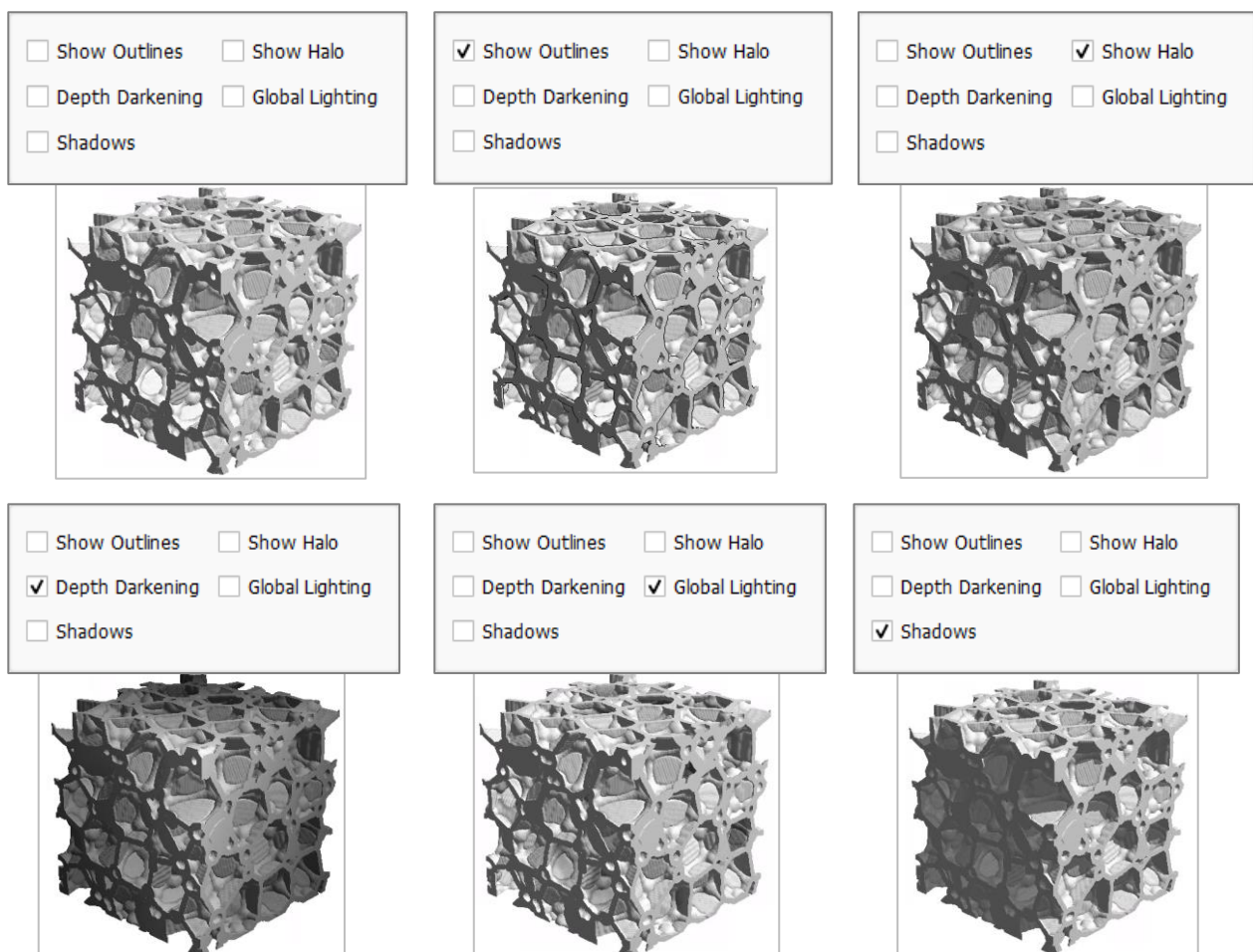

In the Visualization area, with **3D Rendering** view and  selected in the toolbar, rotate the image by keeping the left mouse button pressed and moving it. Zoom by keeping the right button pressed and simultaneously moving the mouse forward. By moving the mouse backward, the image zooms out. Use the middle mouse button to pan and move the structure.

The function of the left mouse button can be changed, by choosing one of the icons:

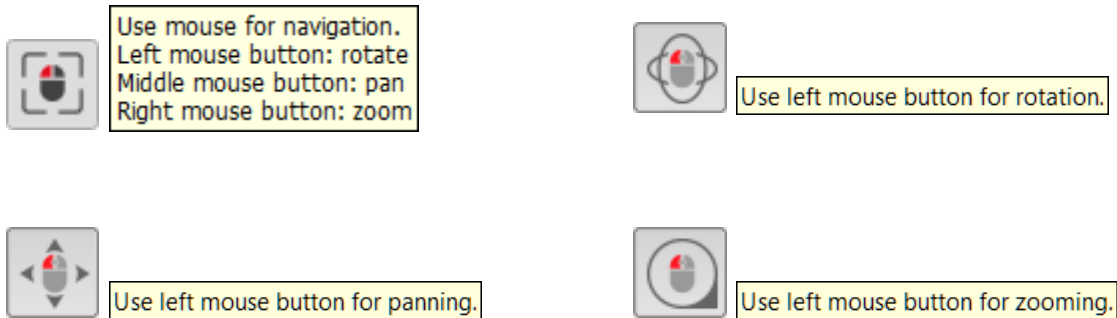

The controls **Translation X**, **Translation Y**, and **Translation Z** determine the position of the structure in the Visualization area. By changing these voxel values in one axis direction, the structure is translated in this direction by the specified number of voxels. When panning the structure with the middle mouse button or using the panning icon , the values in the translation parameter boxes change simultaneously.

The controls **Rotation HDG**, **Rotation ATT**, and **Rotation BNK** define the rotation of the structure in the Visualization area. To reproduce a specific view of a 3D structure, pre-recorded values may be manually entered. The acronyms stand for Heading, Altitude, and Banking and correspond to terminology for aircraft control simulation. When rotating the structure with the left mouse key the values are updated automatically.

Additionally, using the controls **Rotation X**, **Rotation Y**, and **Rotation Z** the structure can be turned around the specified axis.

Clicking the **Reset View** button, the 3D image in the **View Controls** returns to the 0.00 position for all translation controls and rotation controls.

Some additional options and most of the options from the **View Controls** can also be found in the **Visualization Settings** dialog. Expand the **Visualization Settings** dialog either by clicking the gear wheel icon in the bottom right of the Camera tab or by clicking **Visualization tab** in the sidebar and unfolding the **Camera → Camera 3D** section.

Additional to the **Translation** parameters also **Local Translation** can be determined for the three directions. The local translation depends on the structure's rotation, since it always takes place in direction of the geometric axes, displayed in the bottom left of the visualization area.

The **Light** rotation parameters control the position of the light source. The values also change automatically when changing the light position as described on page [16](#).

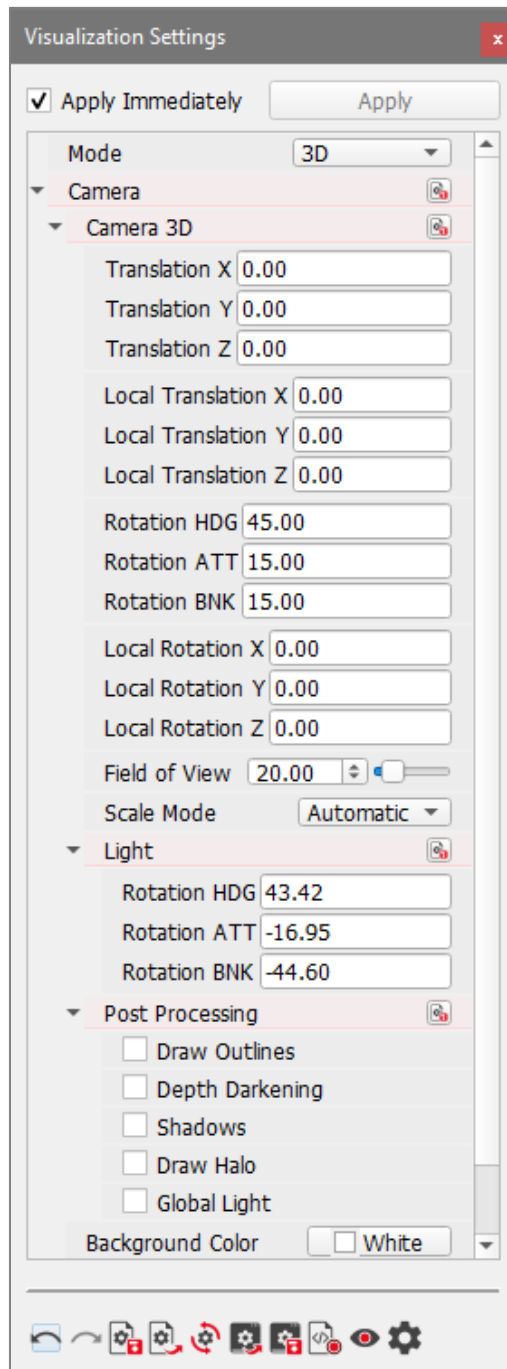

The **Field of View** defines the viewing arc in degrees.

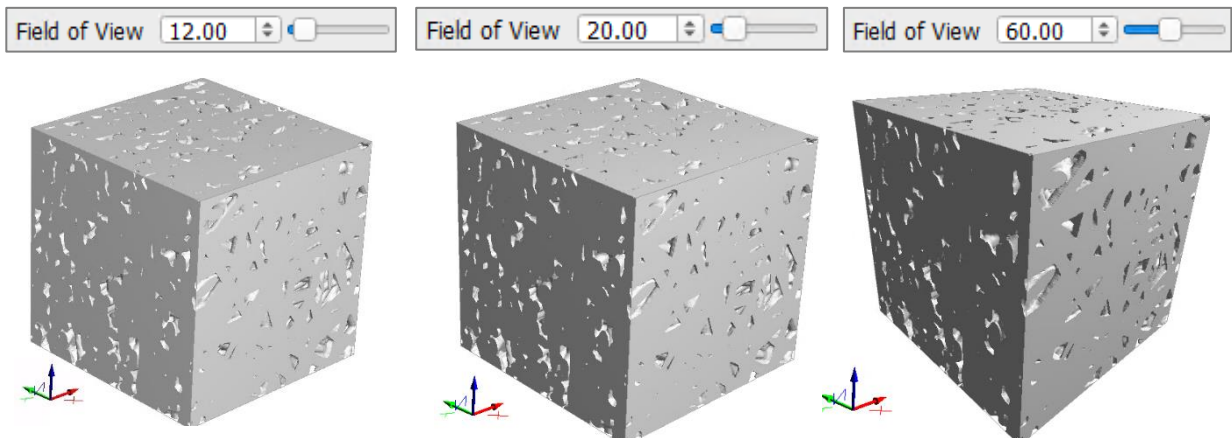

STRUCTURES - GEOMETRY DATA

A fiber structure generated with the **FiberGeo** module of **GeoDict** is used here to explain the visualization settings.

The **Structure** tab is always selectable (when a structure is loaded) and it is checked by default.

By unchecking the **Structure** tab, the structure disappears from the Visualization area because the display is disabled. Only the **Material Legend**, the **Bounding Box** showing the domain, and the **Axes** remain visible.

The same effect is achieved by unchecking **Structure** through the **View** menu or the **Visualization Settings** dialog.

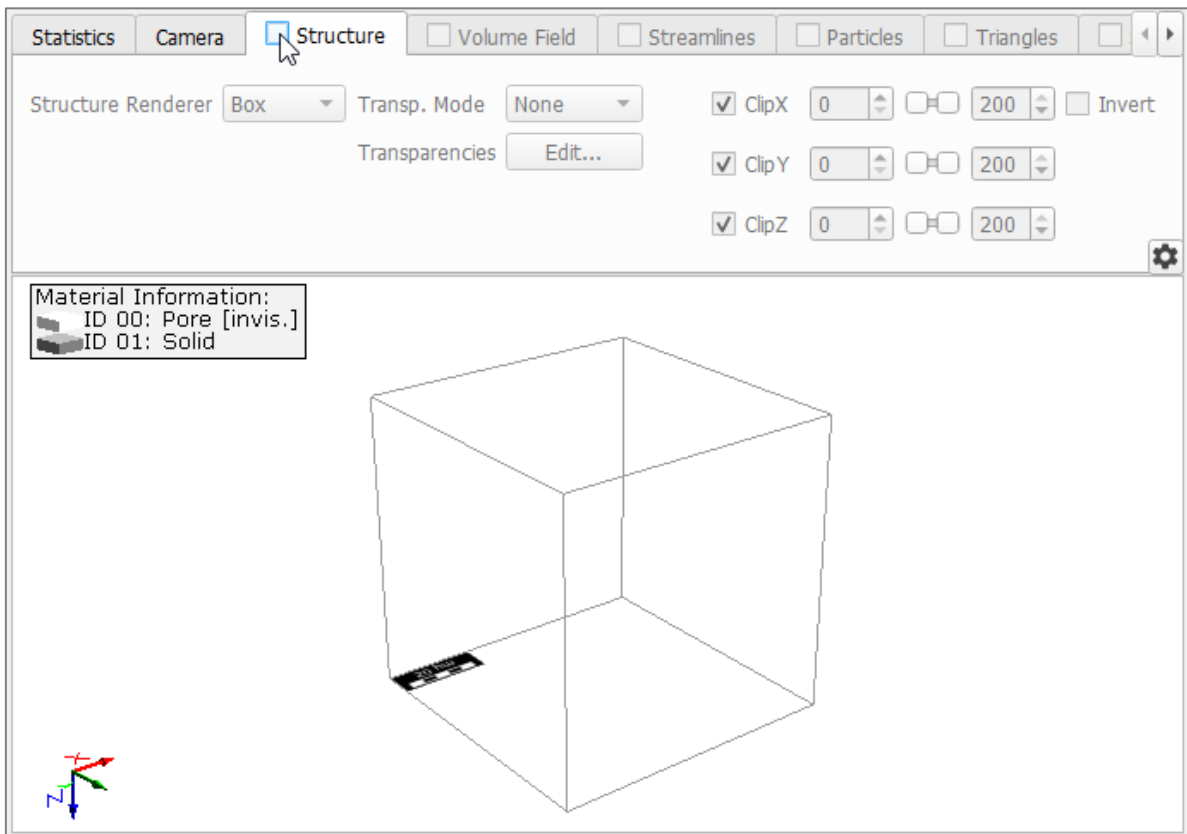
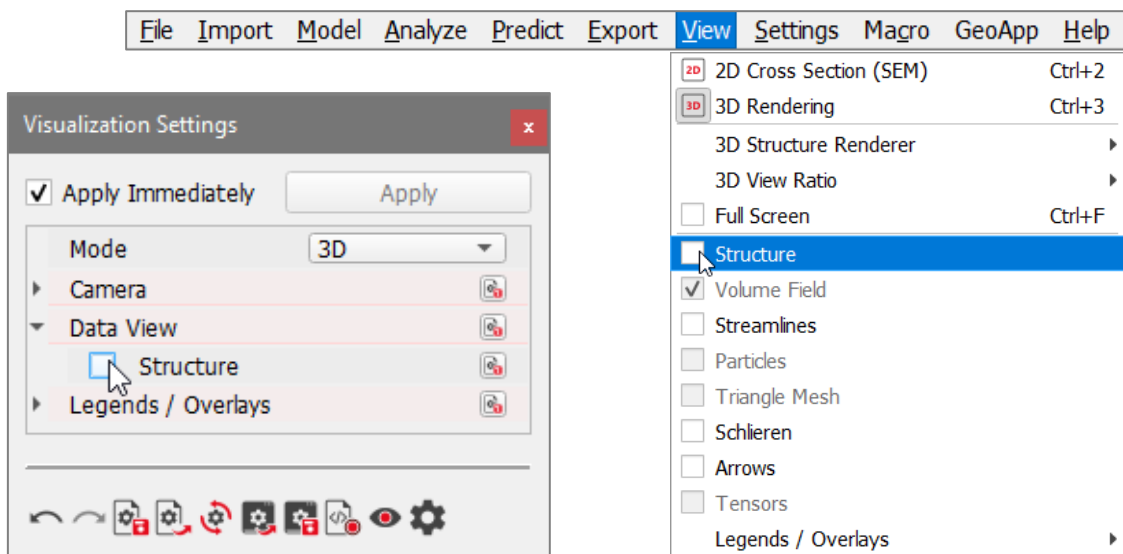

In the **Structure** tab, it is possible to switch between the three 3D **Structure Renderers** (**Box**, **Smooth**, **GPU**). Alternatively, the user can switch between the three **Structure Renderers** through the **View** menu (**View** → **3D Structure Renderer**, see page 4). Additionally, switching between the three is also accessible through the **Visualization Settings** dialog.

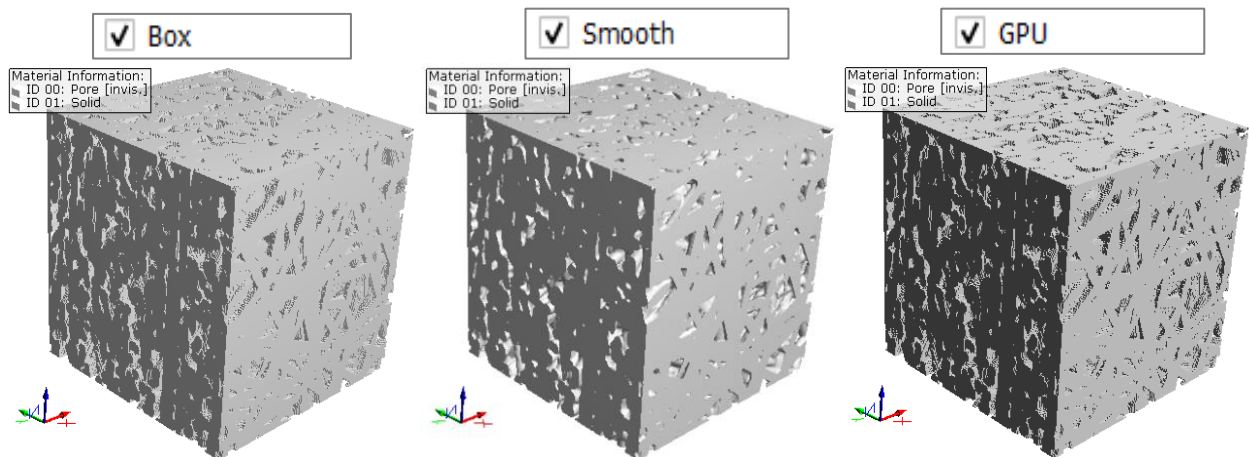
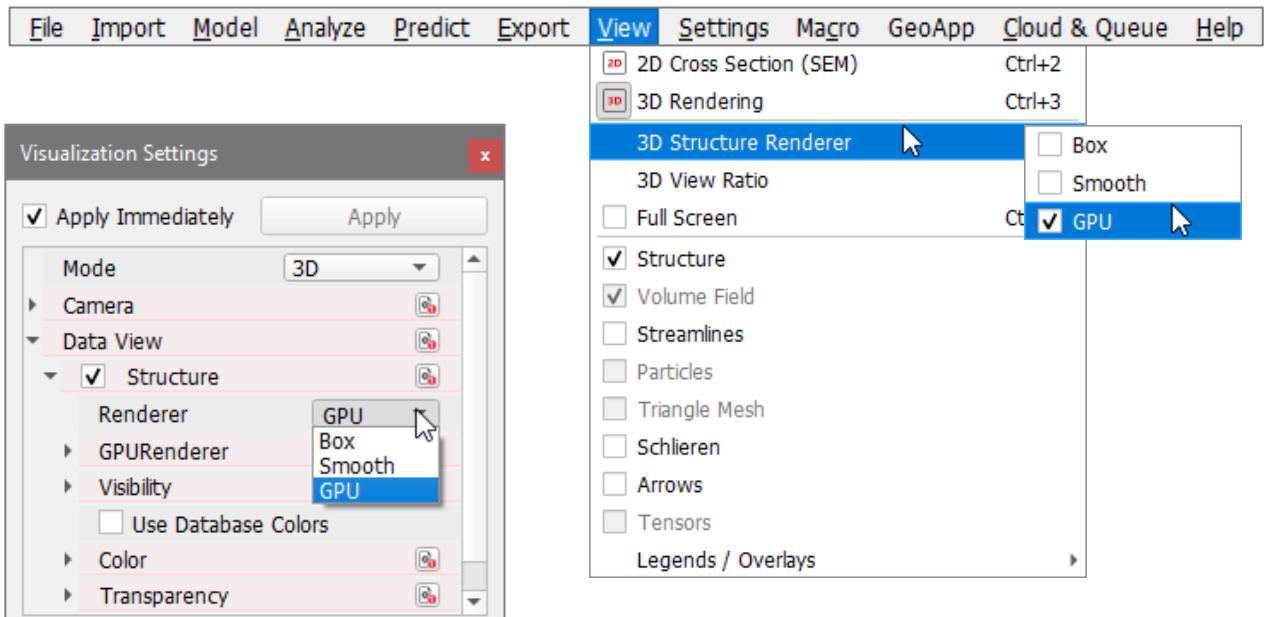
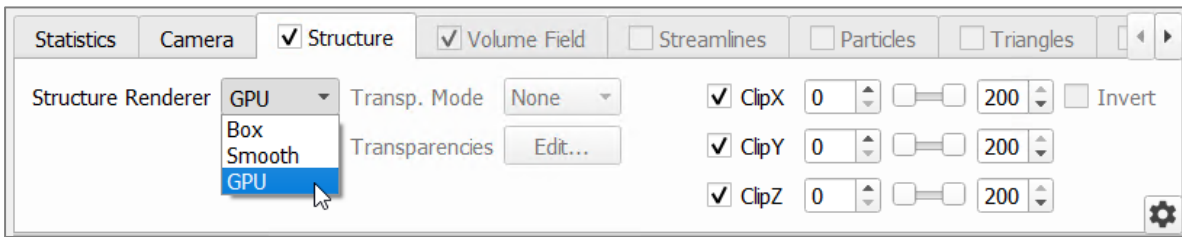

GPU RENDERER

If **GPU** is selected for **Structure Renderer**, in the **Visualization Settings** the **GPU Renderer** section becomes available. Three options can be chosen.

The structure can be visualized as a **Wire Frame**.

Visualize the **Back Faces** of the structure while the front becomes invisible.

Checking **High Quality** increases the quality in trade-off to performance.

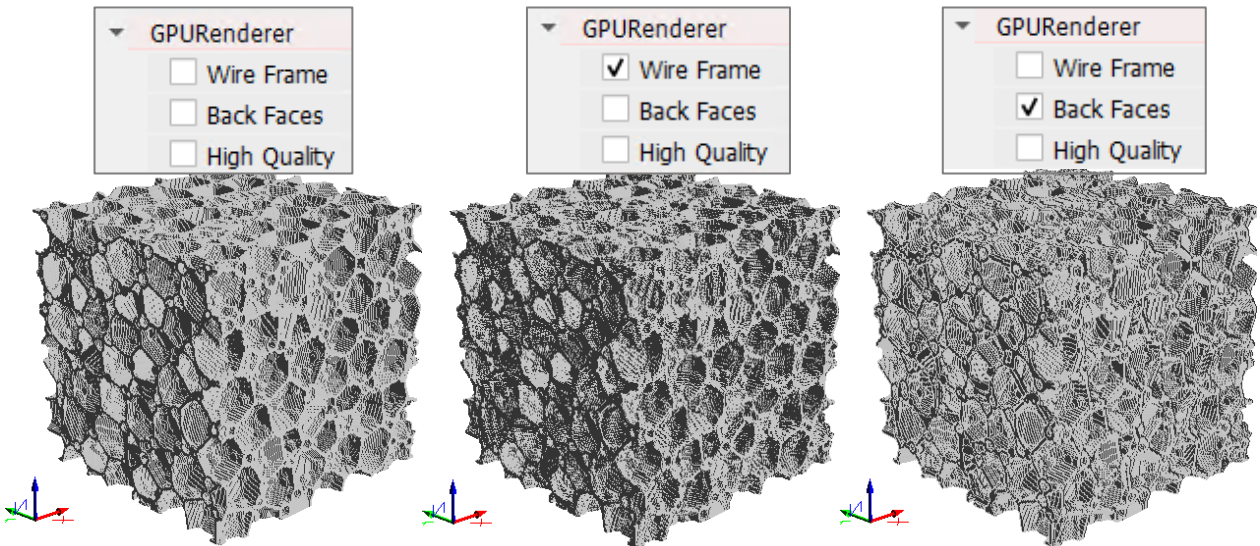

TRANSPARENCY – BOX RENDERER AND SMOOTH RENDERER

While using the **Box** Renderer, transparency can be applied to the displayed structure by selecting **Surface** or **Volume** as the **Transparency Mode**, instead of the default **None**. For the **Smooth** Renderer, transparency is applied after selecting **Volume** (Surface is not selectable)

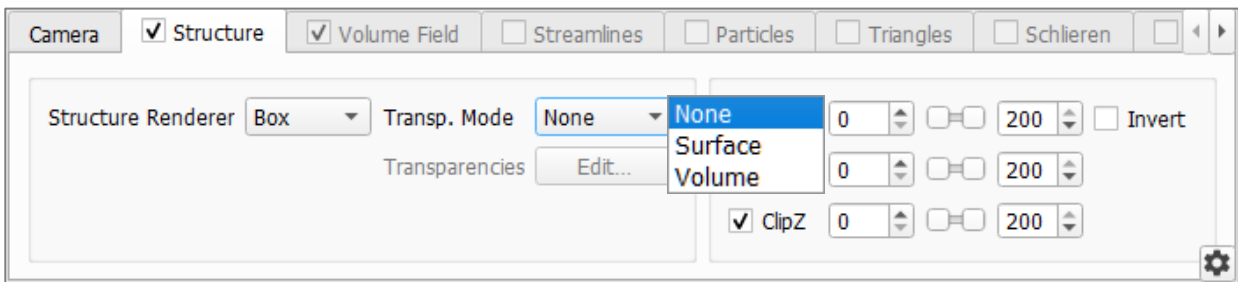

For the choices **Surface** and **Volume**, clicking the **Transparencies' Edit...** button opens the **Transparency Options** dialog. Here, the user can define the transparency level for all materials in the structure.

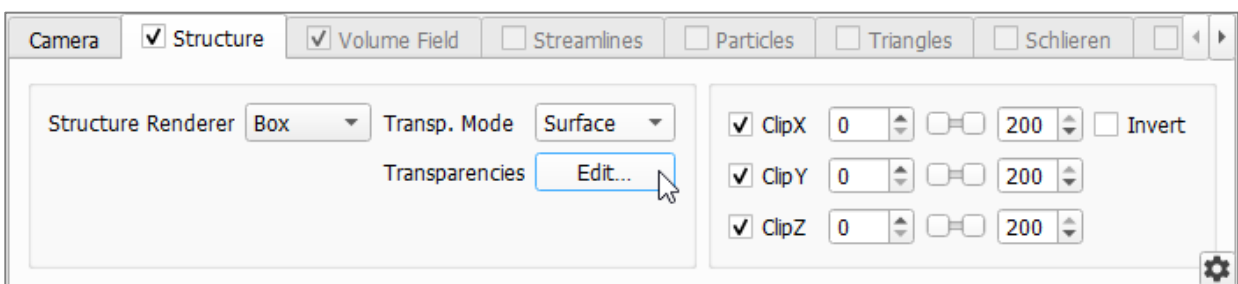

In this example, Material ID 00 is set to invisible, but the transparency of Material ID 01 (solid) can be defined with values between 0 and 1. The smaller the value, the more transparency is applied.

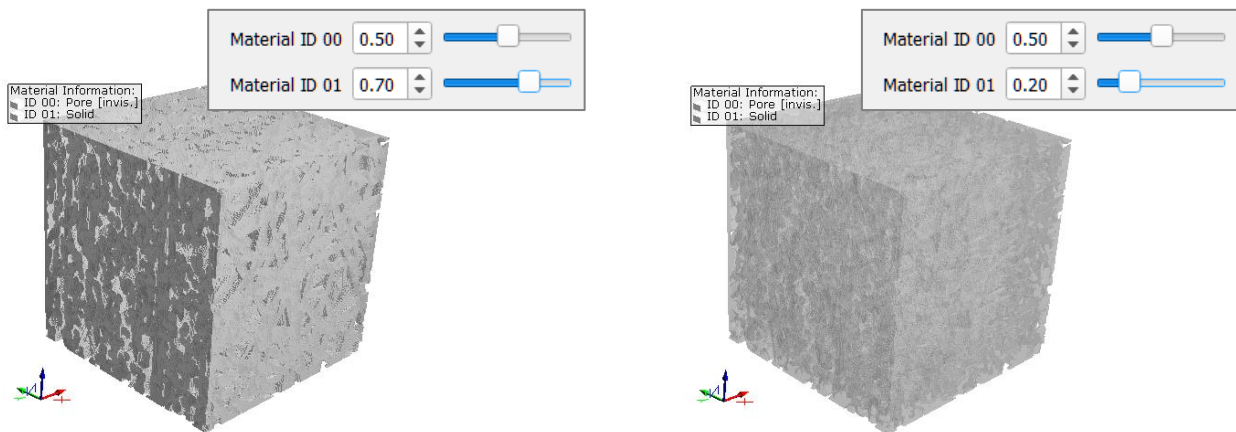

Additionally, the transparency options are also accessible through the **Visualization Settings** dialog.

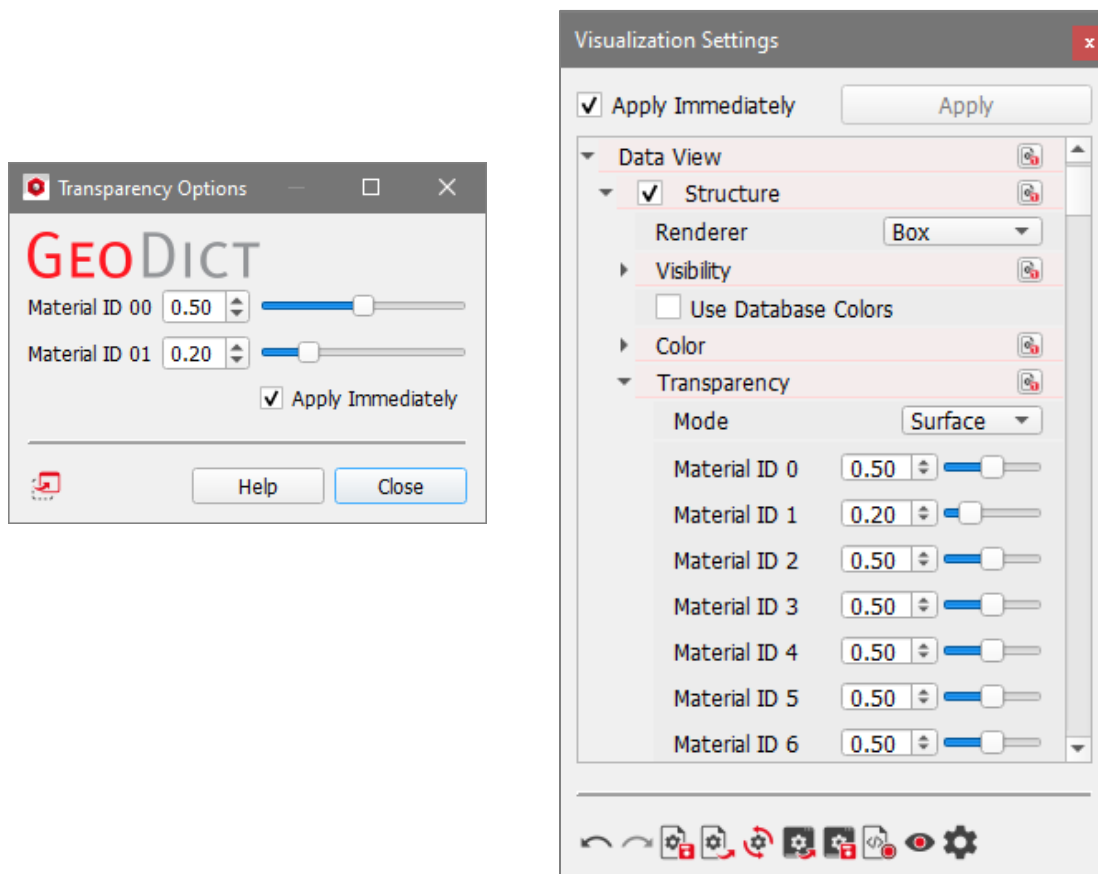

The **Transparency** for the **Smooth** renderer is similar as for the **Box** renderer, but there is an essential difference: Transparency can be only applied to a single material in the displayed structure.

After selecting **Volume** as the **Transparency Mode**, select the material to which transparency is applied (**Transparent Material**) and the level of transparency. The smaller the value, the more transparency is applied.

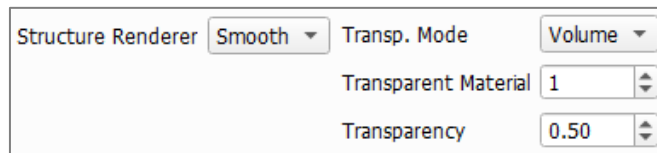

On the right side of the **Structure** tab and in the **GUI Sidebar, Clipping** of the values **ClipX**, **ClipY**, and **ClipZ** (or **X**, **Y**, and **Z**) allows cutting the displayed geometry in all three spatial directions with the sliders or by direct input.

Additionally, after defining a clipping area with the sliders or direct input, the user can limit this as the area of interest by checking **Invert** in the **View Controls** or selecting **Invert Clip Area** for **Clipping Mode** in the **Visualization Settings** dialog. Only the area defined by the clipping values remains in the Visualization area.

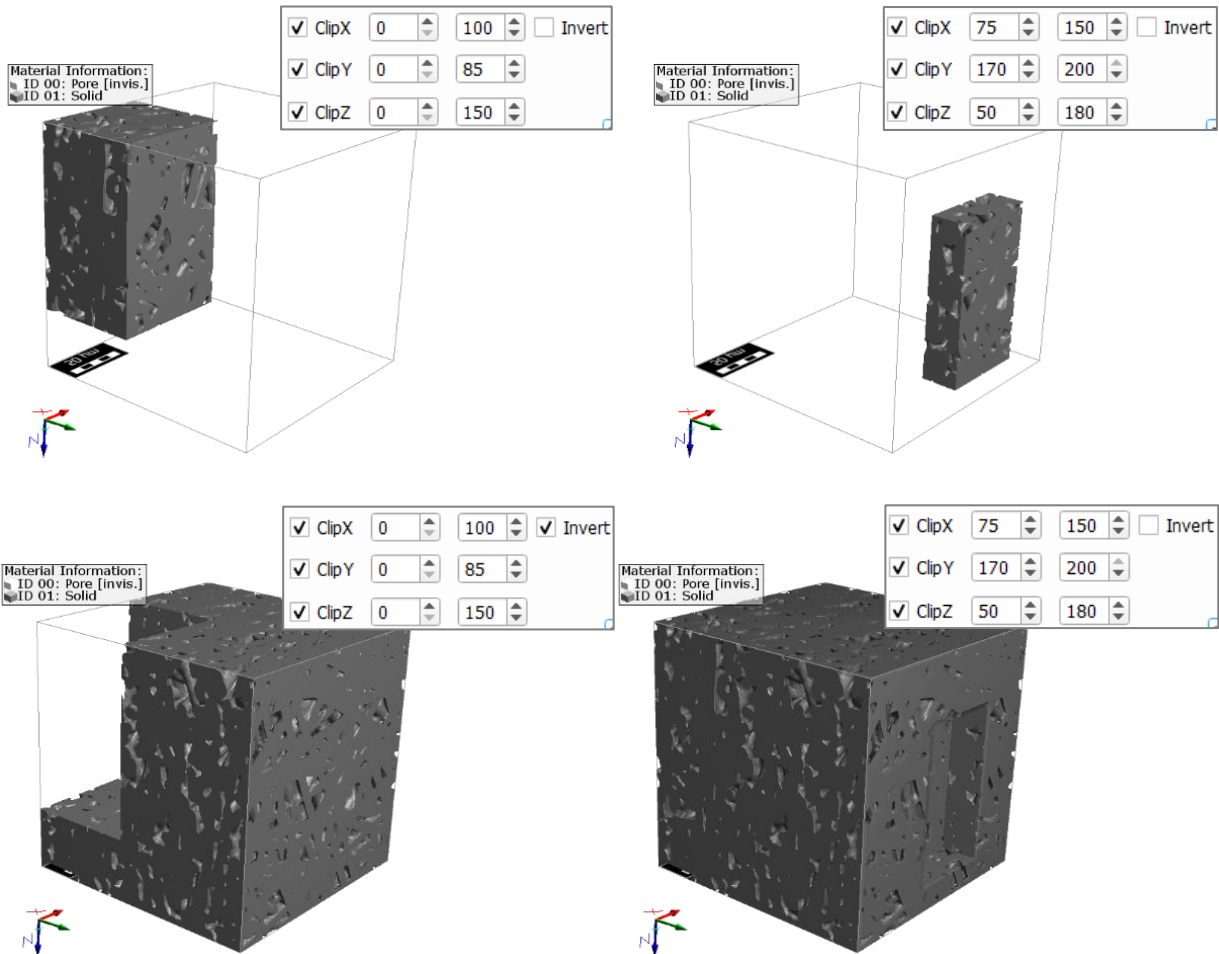

USE DATABASE COLORS

Enabling the checkbox **Use Database Colors** in the **Structure** section of the **Visualization Settings** dialog sets the colors of the constituent materials according to their defined color from the **GeoDict** material database. If the material is set to **Manual**, the color is not changed. Changing the color afterwards disables the checkbox.

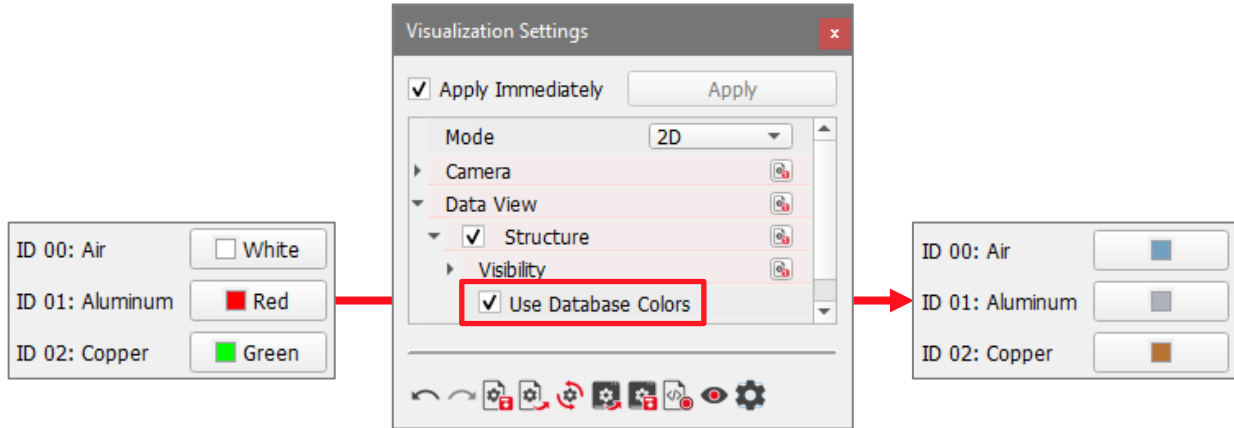

The material color can be defined in the Material Database accessible by selecting **Settings Open & Edit Material Database** from the menu bar or by clicking the corresponding icon  in the toolbar.

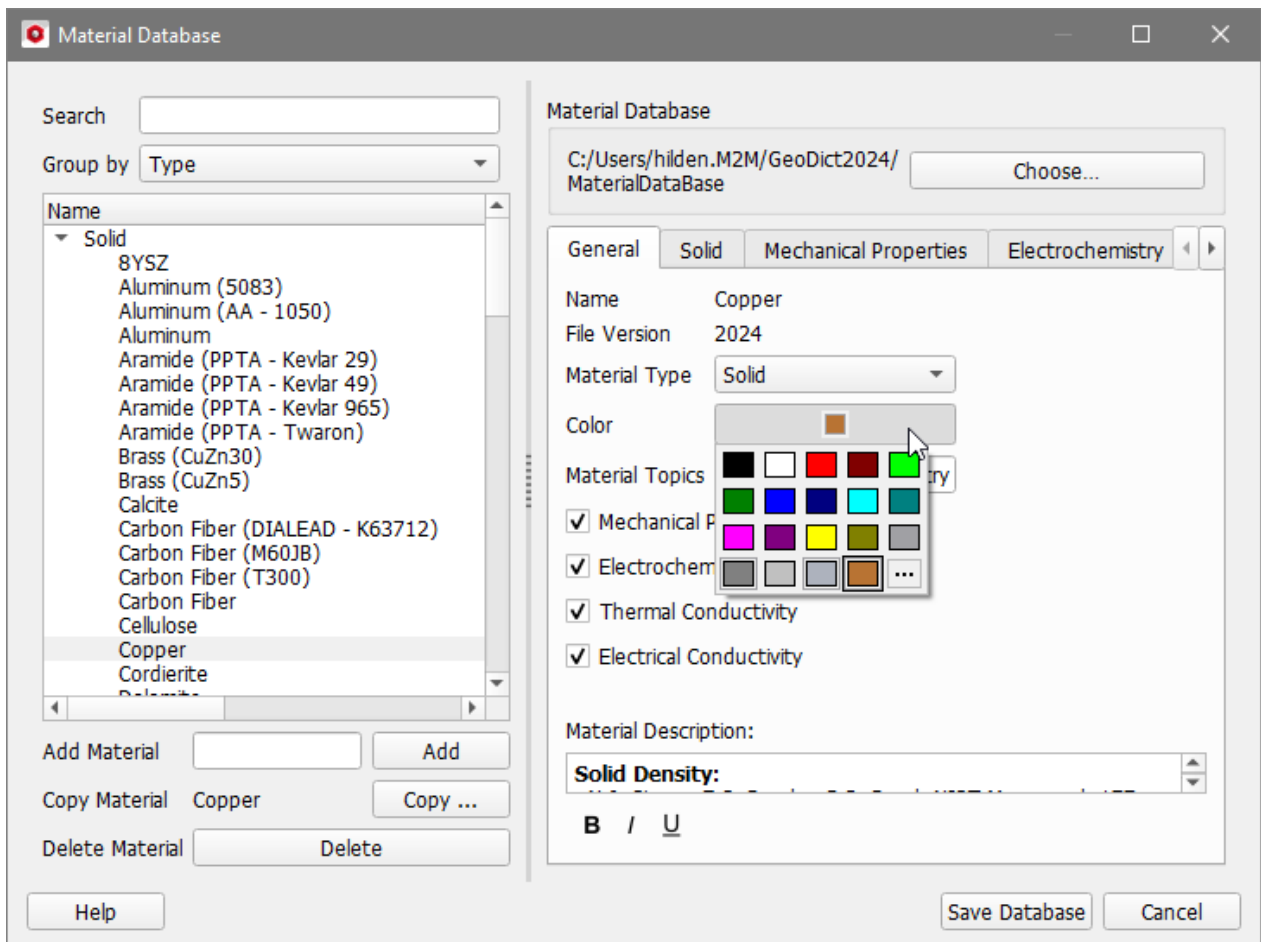

For more detailed information on the material database refer to the [GeoDict Material Database](#) handbook of the User Guide.

RESULT FIELDS – PROPERTY DATA FROM SIMULATIONS

Open a result file (*.gdr) by clicking the  icon in the toolbar and navigating to the location where the file was saved. Here, the result file was obtained after running a Filter Life Time simulation with FilterDict and the name of the file is the default FilterLifeTime.gdr.

The **Result Viewer** of the result file opens at the **Results – Report** tab. Observe the results in 3D view by selecting **View → 3D Rendering** in the Menu bar.

VISUALIZATION OF PARTICLES

Click the **Particle Visualization** tab. Buttons in three panels give access to the visualization of particle trajectories, the visualization of the particle positions with time, the visualization of the deposited dust with time and the visualization of the fluid flow field.

In the **Particles** panel, move the slider to select the **Batches** of particles to be visualized. For example, keep the choice to visualize all batches that ran in this filtration simulation, which is batches 1 to 11 in the example.

Trajectories should be checked to observe the movement of the particles.

Then, click **Load Particles**.

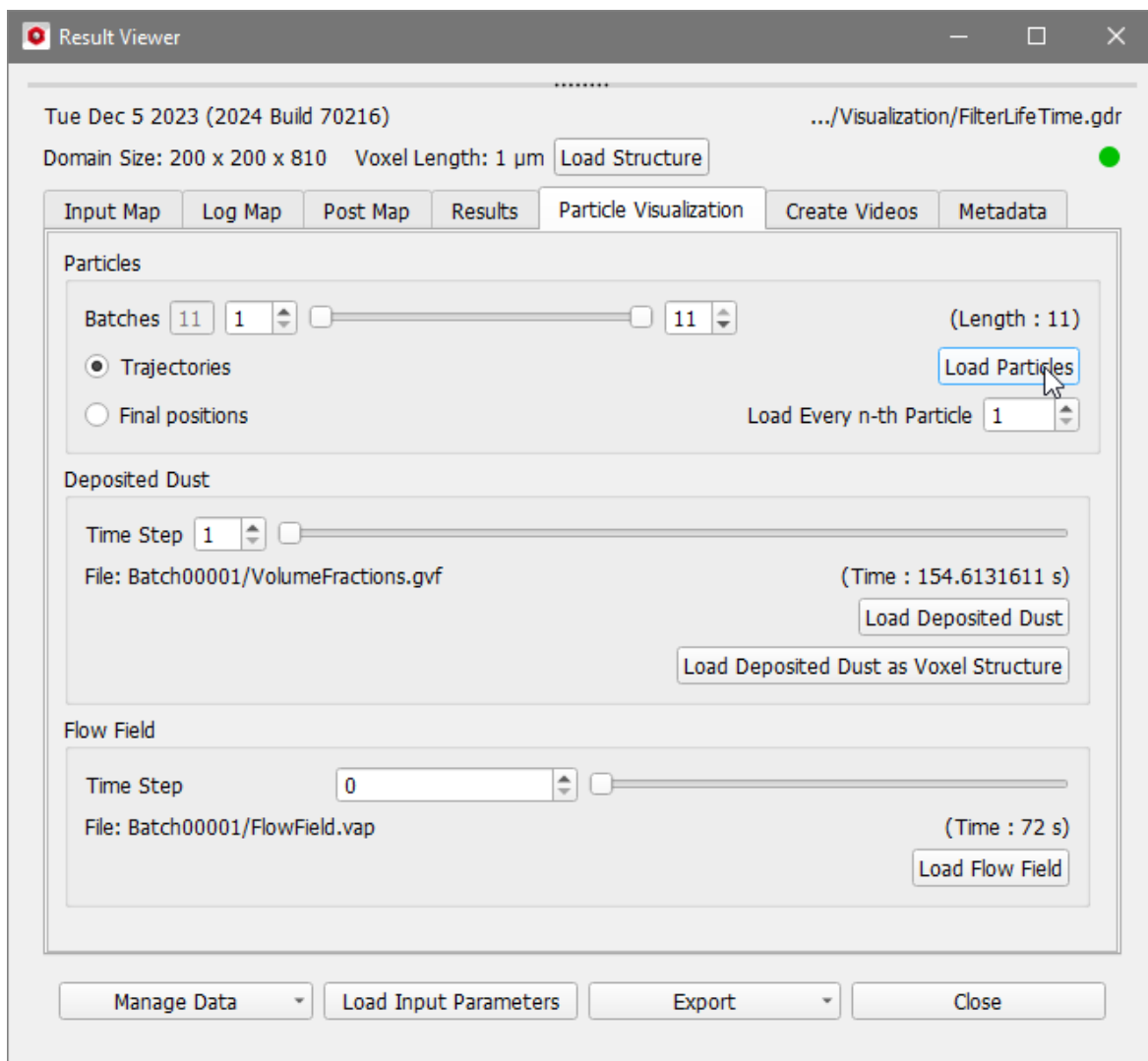

The structure model appears in the Visualization area in 3D Rendering with the stationary particles of Batch 1 above the structure (at the inlet domain).

At the bottom-right of the visualization area, observe the **Batch** number and the point in **Time** of the filtration process. In case they are not shown there, enable the checkbox **Show Overlay** in the **Particles** section of the **Visualization Settings** dialog.

Above the Visualization area, in the **View Controls**, the parameters for the visualization of the particles during the filtration process simulation are selectable under the **Particles** tab.

Additional parameters can be found in the **Visualization Settings** dialog as always by clicking the gear wheel icon in the bottom right of the **View Controls**

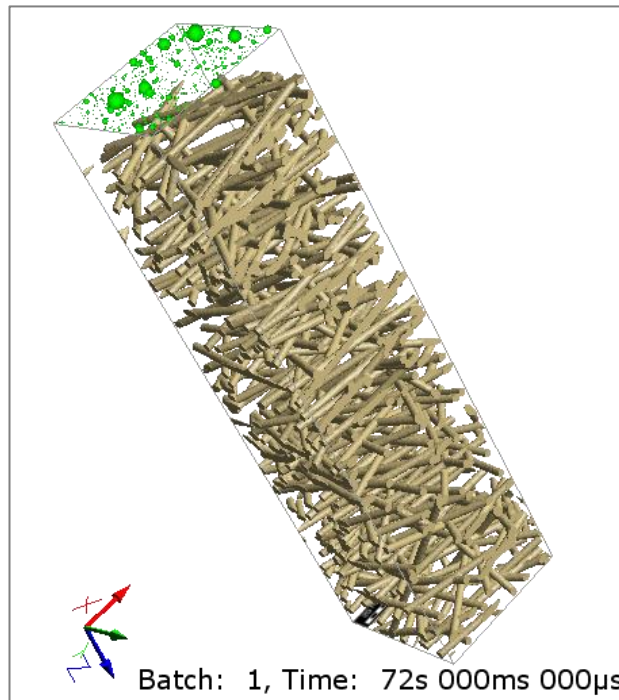
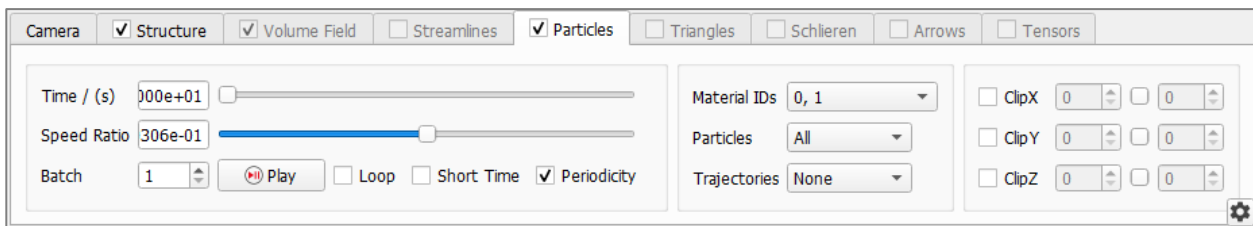

In the **Visualization Settings** dialog (**Data View ► Particles**), control the **Color Scheme** by selecting between **Moving State**, **Material**, **Size**, and **Batch ID** from the pull-down menu.

If **Moving State** is selected for **Color Scheme** the default **Green** color of the non-filtered particles can be changed with **Moving Color**. The color of the filtered particles can also be changed from the default dark gray with **Deposited Color**.

For **Material**, **Size**, and **Batch ID** the colors are selected automatically and depend on the selected property.

Sometimes it is useful to switch off the visualization of the structure by deselecting **Data View ► Structure**.

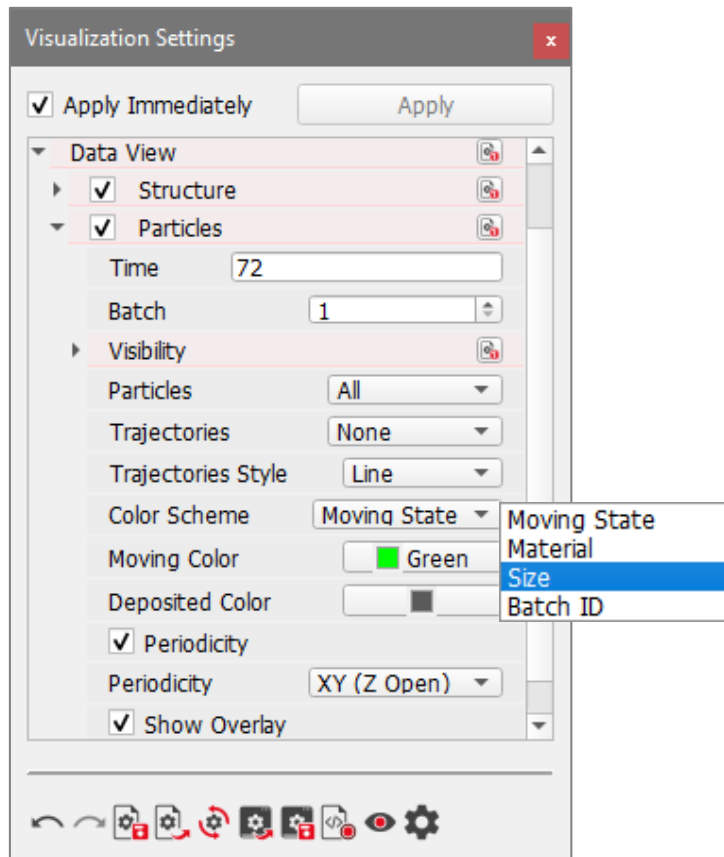

In the **View Controls**, the sliders for **Time** and **Speed Ratio** control the visualization of particle movement. Moving the slider or directly entering a **Time** allows displaying the particles at a particular point in time.

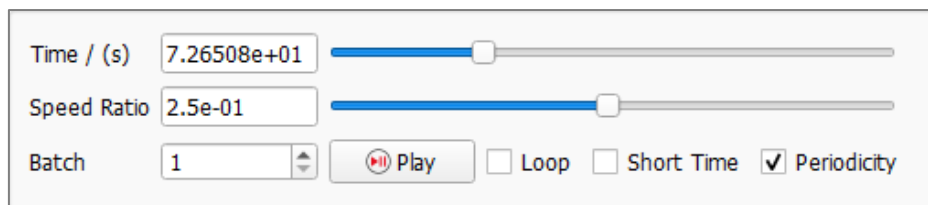

The **Speed Ratio** controls the visualization speed by entering values directly or by moving the slider. Low values of **Speed Ratio** result in the particle movement process being shown in slow motion, whereas high values lead to faster motion.

The animation of the particles, in which the particles move through the filter structure, starts by clicking **Play**. The **Batch** number changes from 1 to the last batch, as the batches of particles appear in the inflow region above the filter media model and pass through it. The bigger particles are caught and held by the filter material whereas the smaller ones pass through to reach the outflow region.

The **Time** slider does not return to zero when the animation has finished and must be set to the initial value to restart the animation. However, checking **Loop** makes the animation play endlessly.

Checking **Short Time** adapts the visualization **Time** to the period when most of particles move. This option cuts off the final part of a simulation where only a few particles move at very low velocities and virtually no changes are visible to the observer.

Checking **Periodicity** activates periodic boundary conditions for the visualization of the simulation results. This is only recommended if the simulation was also done with

periodic boundary conditions. In the **Visualization Settings** dialog, select where to apply periodicity from the pull-down menu for **Periodicity**. If for example, **XY (Z Open)** is selected, the periodicity is only applied in X- and Y- direction, while the Z- direction is open for particle movement.

Below, two images of batches 1 and 9 are shown. The color of the particles hovering over the structure has been changed from the default green to red. The deposited particles are shown in dark gray.

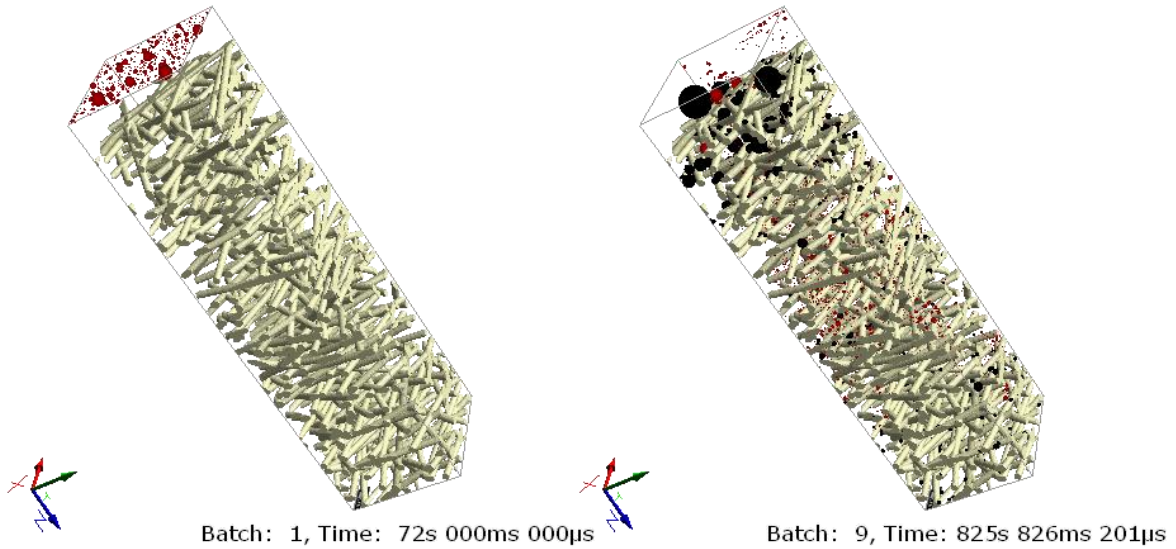

Clip the particle visualization area by enabling a clip direction, and moving the corresponding sliders or entering clipping values.

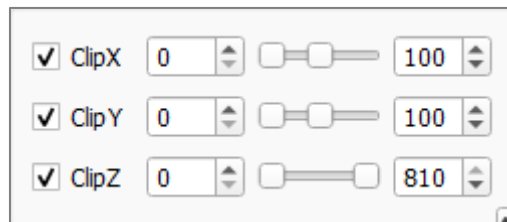

Otherwise, in the **Visualization Settings** dialog, use the option **Data View ▶ Particles ▶ Visibility ▶ Clipping**, working the same way as described for the Volume Field on page 67.

If the particles move through different materials, choose the **Material IDs** where the particles should be visible.

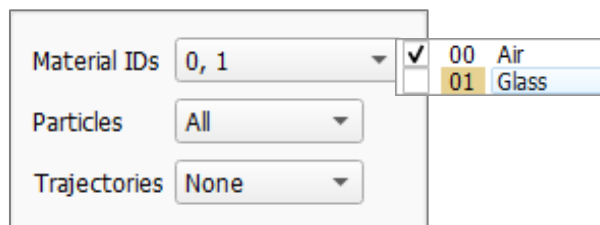

Custom Visualization of Particles

The display of the particles moving through the filter media model and their trajectories can be customized.

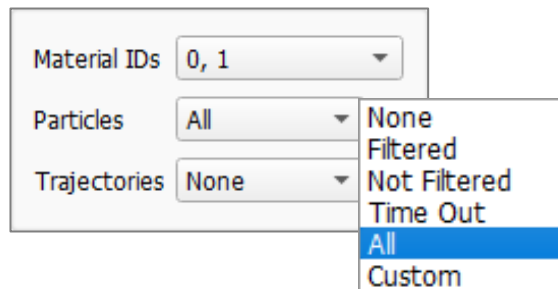

The **Particles** and **Trajectories** pull-down menus can be set to:

- **None** to show no particles (or no trajectories),
- **Filtered** to show only the filtered particles (or their corresponding trajectories),
- **Not Filtered** to only show the particles that are not filtered (or their corresponding trajectories),
- **Time Out** to display only particles (or their corresponding trajectories) whose movement could not be simulated completely within the time defined for each batch. For example, in some cases, a few particles can have very small velocities in the inflow region compared to most of particles and therefore their behavior cannot be simulated completely within the defined batch time,
- **All** to show the particles (or their corresponding trajectories) caught in the structure and those that went through it, or
- **Custom**. This option is only available in the Particles pull-down menu, but also applies for trajectories.

When choosing **Custom** for the visualization of **Particles**, the **Edit Custom...** button overlays and replaces the standard **Trajectories** pull-down menu described above. Now, the visualization of trajectories is controlled through the **Visualization - Trajectories** option of the **Custom Particle Selection** dialog.

Settings for a user-defined, customized visualization can be defined by clicking the **Edit Custom...** button. The **Custom Particle Selection** dialog opens.

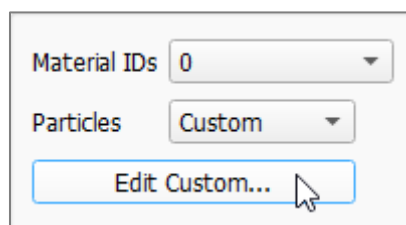

The **Custom Particle Selection** dialog may remain open to observe the changes that the selections have on the visualization of particles moving through the structure. The custom particle options can be changed while the particle animation is playing, so that the effect of the selection can be observed immediately.

Clicking **Add Selection** adds the current batch of particles to the visualization and generates **Selection 1**.



The selection can be disabled by unchecking the corresponding checkbox or deleted by clicking **Remove**.



Clicking at the left of **Selection 1** opens the options: **Previous Batches**, **Diameter Selection**, **ID Selection**, **Type ID Selection**, **Final State**, **Deposition Zone**, **Multiplicity**, and **Visualization**.

Parameters for all these options are accessed by clicking on their symbol.

To see all previous batches, check **Previous Batches**. When left unchecked, only the particles of the current batch can be seen.

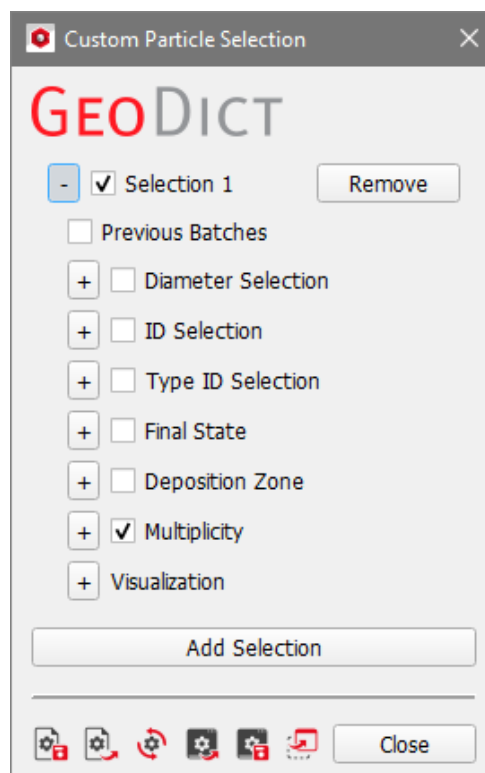

Diameter Selection

Checking **Diameter Selection** limits the visualized particles to those with a particle diameter in the range specified by min and max. This option only has an effect if the particles exhibit a particle size distribution.

ID Selection and Type ID Selection

Every particle has a specific **ID** and a specific **Type ID**. Every particle is counted and has its own specific **ID**. Furthermore, every diameter has its **Type ID**, which means that if you have 30 different diameters, there are 30 different Type IDs.

The **ID Selection** and **Type ID Selection** work analog to the **Diameter Selection**, merely picking out particles based on their individual particle number and specific **Type ID** rather than their diameter.

Final State

Final State enables the visualization of particles that obtained a particular state at the end of the simulation.

In the **Not Filtered** panel, particles that did not get attached to the filter/porous medium are selected as follows:

- **Out-Flow** denotes particles that left the computational domain via the fluid outflow region.

- **In-Flow** designates particles that left the computational domain via the fluid inflow region.
- **Time-Out** identifies all particles that do not stick to the porous medium and did not leave the computational domain via the inflow or outflow, i.e. slow particles.
- **Hit End Material** only shows particles which hit the end material. This only applies if the **Particle End Position** in the simulation is set to material ID and not to the outflow plane.
- The **Max. Displacement reached** state can only be achieved in **AddiDict**.

The **Filtered** panel contains the options for particles that became attached to the filter/porous medium:

- **Adhesion** selects all particles that are attached to the porous media because of adhesive forces.
- **UDF** selects all particles that are filtered by a model from a user defined function (UDF). This is only available for **FilterDict** results.
- **First Touch** selects particles that stick to the porous media on the first time they touch it.
- **Sieving** selects particles that simply lie on the porous media but do not stick to it, like happens in the other two options.
- **Pass Through** selects particles that are filtered by the pass-through model.
- **Adsorbed** selects particles that were adsorbed in a porous medium. The adsorption model is only available in **AddiDict**.

Deposition Zone

The **Deposition Zone** defines a location in the computational domain where the particles must be situated at the end of the simulation to be eligible for visualization. This zone is delimited by the min / max coordinates of the Cartesian direction in which fluid flow occurs, i.e., Z-axis.

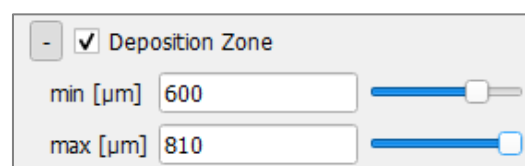

Multiplicity

Particles can be selected depending on their multiplicity. Particle Multiplicity is a simulation option for unresolved particles which helps reducing simulation time for very small particles. For detailed information see the [FilterDict](#) handbook of the User Guide.

Visualization

Checking **Visualization** allows more adjustments for the visualization of simulation results.

Checking **Particles** displays all particles that conform to the options previously set in the dialog.

Checking **Trajectories** displays the trajectories which correspond to the selected particles. With this option, it is (for example) possible to show only the trajectories which correspond to a certain particle type.

Checking **Periodic** enables periodic boundaries for the particle movements display. Particles which leave the domain at one side re-enter at the opposite side.

Green, the default color for the particles, can be changed to another color through the button (for example, ■ Dark red).

The **Diameter Factor** scales the particles sizes relative to their original size for visualization purposes and enables the display of particles that are nominally below the visibility of the visualization settings. The diameter of all particles moving in the simulation artificially grows by this factor when visualizing them.

Clicking **Add Selection** again makes a new selection appear (e.g., Selection 2), to combine different visualization selection models and is useful to observe, for example, particles with two different diameter ranges (through **Diameter Selection**).

As an example, here, we show the settings to visualize particles with a diameter from 0 μm to 2 μm in ■ Dark red, and particles with a diameter of 3 μm to 5 μm in ■ Dark cyan.

Particles with a diameter bigger than 2 μm and smaller than 3 μm are not shown at all.

Here, only particles with a **Deposition Zone** between 0 μm and 150 μm will be visualized.

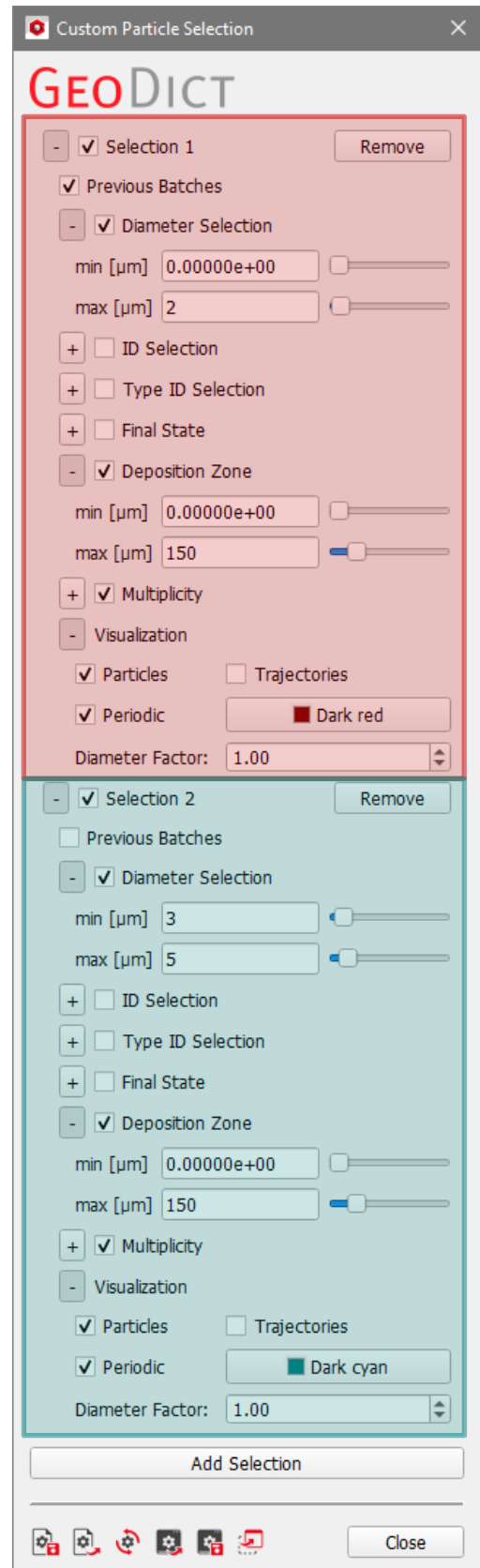

VISUALIZATION OF VOLUME FIELD

To visualize the volume field, in the Result Viewer of the result file, under the **Particle Visualization** tab, in the **Flow Field** panel, click **Load Flow Field**.

Note: Visualizing particles simultaneously with the flow field is also possible.

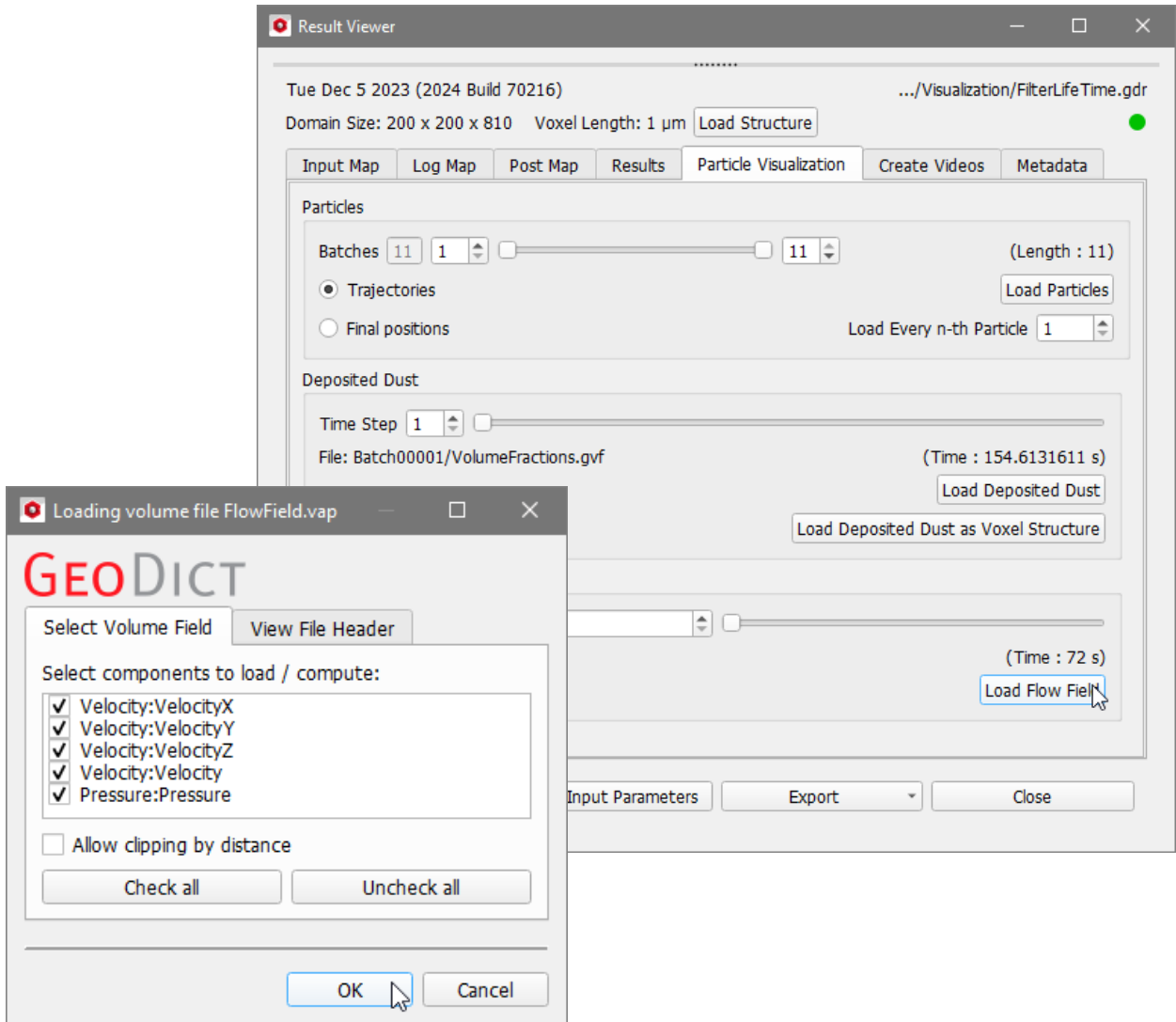

In the **Loading volume file FlowField.vap** dialog, select the desired components of the flow field to be shown. Click **OK**.

The structure model and the flow field are shown in the Visualization area in 3D Rendering.

Above the visualization area, in the **View Controls**, the parameters for the visualization of the flow field are selectable under the **Volume Field** tab. If needed, the visualization of the structure can be switched off by unchecking the **Structure** tab box.

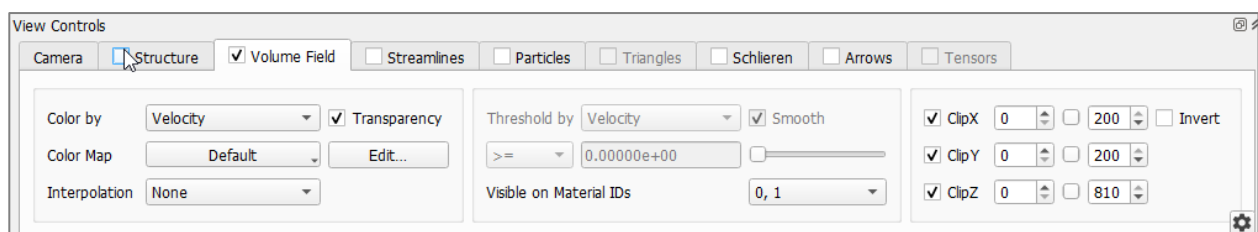

The data of a particular flow field component can be chosen for display from the **Color By** pull-down menu (here it is Velocity).

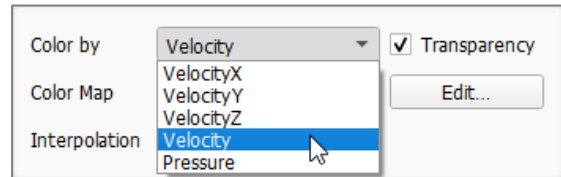

Clicking **Edit** for **Color Map** opens a dialog to fine-tune the visualization of results. The settings in the **Color Map** dialog were explained above in pages [34ff.](#)

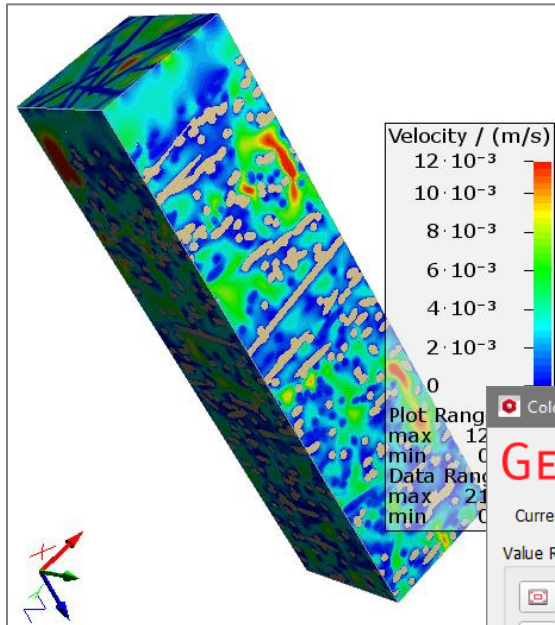

For example, in the **Color Map** dialog, the user can use the set **Percentile High** and **Percentile Low** clipping values and then, check **Transparency** and move the points in the transparency curve as follows:

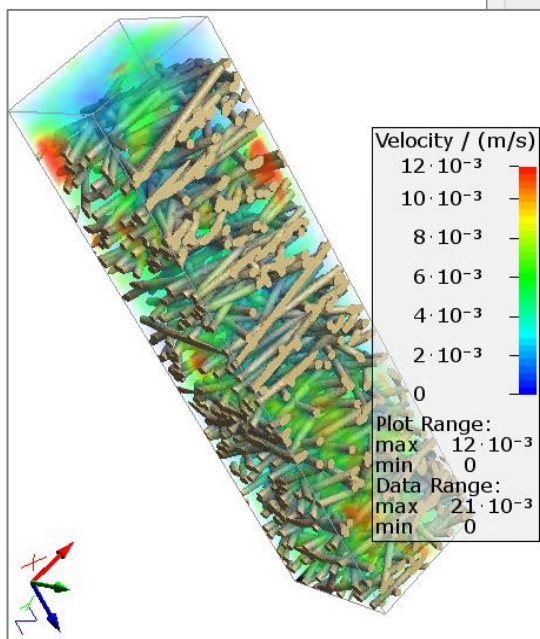
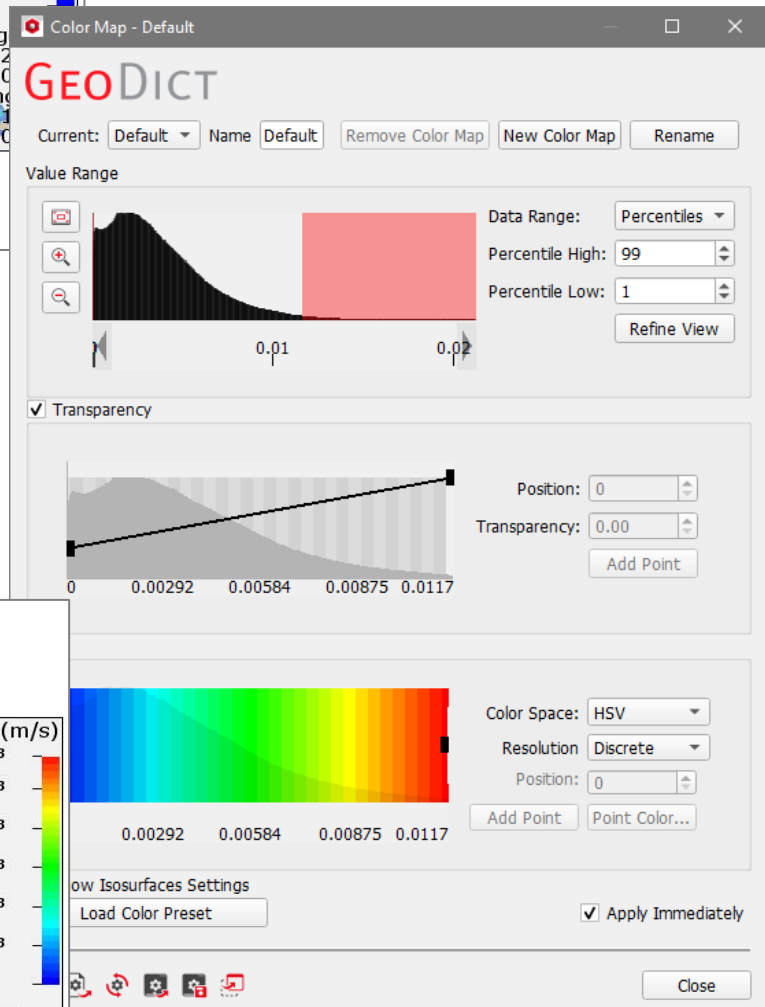

In 3D rendering now also the **Isosurfaces** in the **Color Map** dialog can be displayed, if **Transparency** is checked. Enable **Show Isosurfaces Settings** and emphasize selected values in the volume field, by changing their transparency. Note, that disabling the checkbox does only hide the isosurfaces settings in the Color Map dialog and not the isosurfaces in the visualization area.

Click **Add Isosurface** to add a point in the graph. Move the point as desired or enter a **Position**. Set the **Transparency** and the color for the selected isosurface.

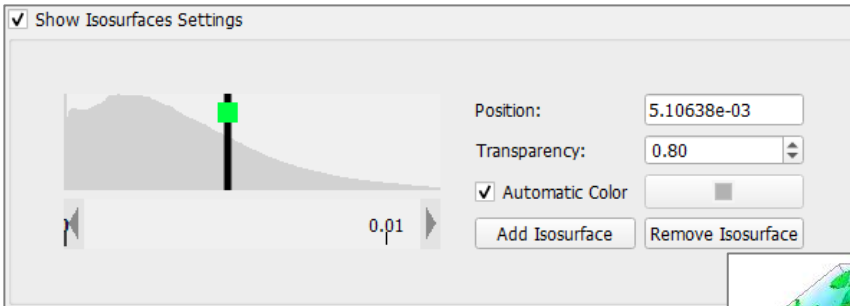

In the example, the **Structure** tab in the **View Controls** is disabled and the transparency settings are as shown above. An isosurface was added for a velocity of 0.005 m/s and the transparency was set to 0.8. As **Automatic Color** is checked, the color of the value is not changed, but due to the higher transparency value, the green isosurface is emphasized.

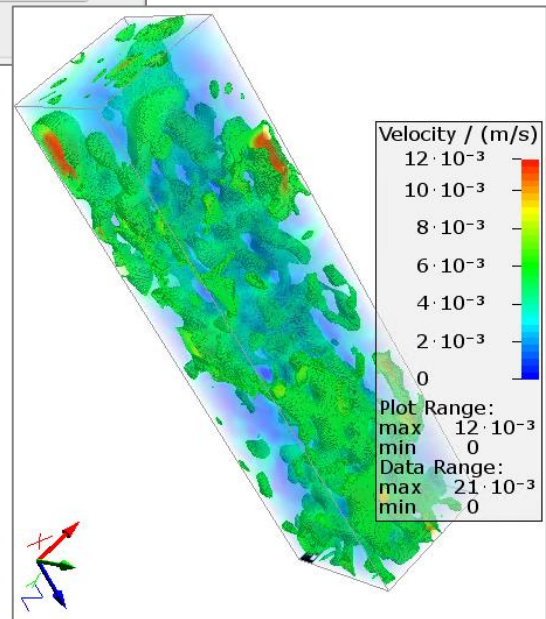

Transparency can also be enabled or disabled from the **View Controls** or the **Visualization Settings** dialog. In the **Visualization Settings** dialog, also the overall transparency **Density** can be changed.

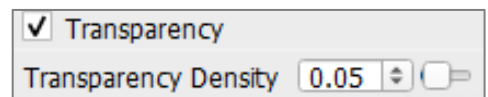

The settings for the display of flow field isosurface **Lines** through the **Visualization Settings** dialog (from the Sidebar) are explained above in pages [39ff](#), and are only visualized, if transparency is disabled.

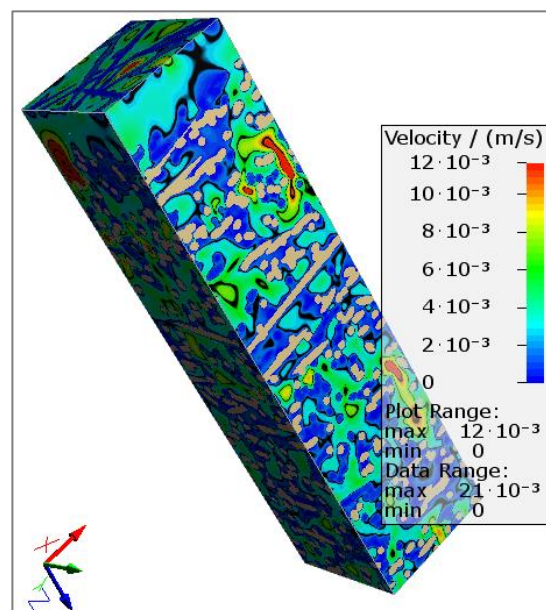

For most volume fields, by default, the colors of the volume field are not interpolated and just the raw voxel values are shown. In the **View Controls** and in the **Visualization Settings** dialog, several options are available for **Interpolation**.

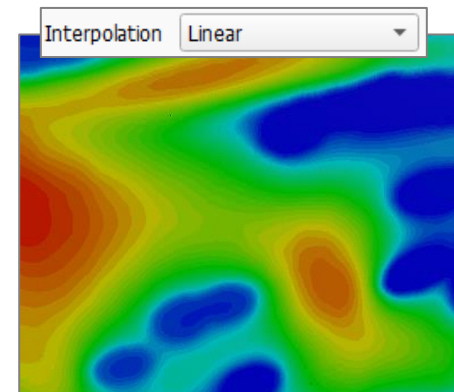
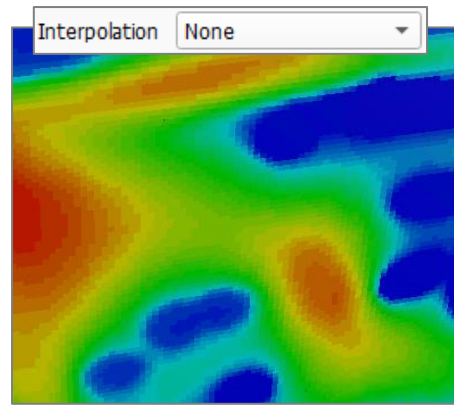
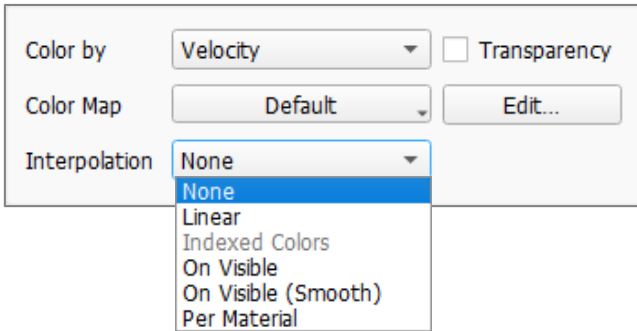

Select **Linear** to interpolate the colors linearly between surrounding voxel centers.

Indexed Color is only available for integer fields, as for example *.g32 files. For integer fields, usually this is the default setting. If selected, the different index values have distinguishable colors.

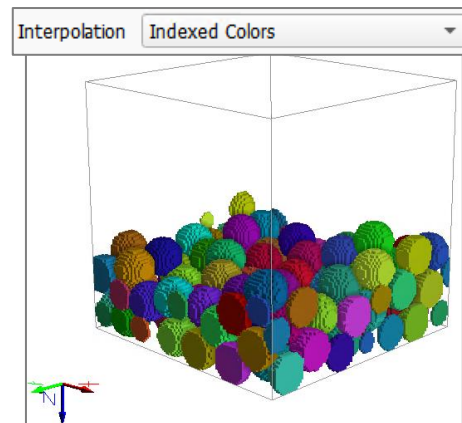
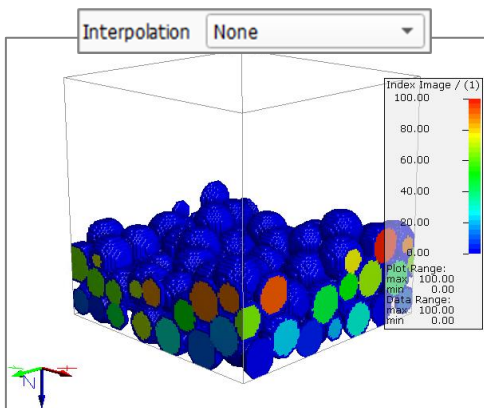

Choose **Interpolation on Visible** to interpolate the colors linearly between surrounding voxels, while not interpolating into invisible areas. Thus, color fringes are removed. In the example on the right, material ID 01 is selected as invisible. Thus, the flow field is not visualized in the glass fibers.

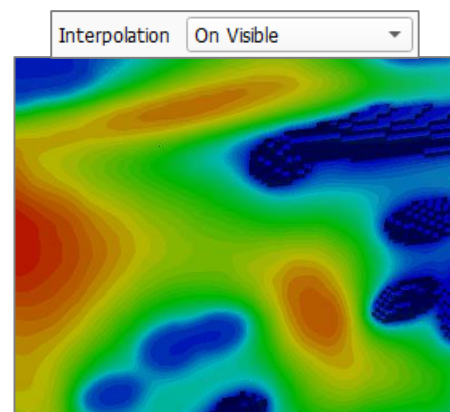
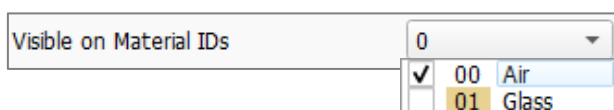

Interpolation **On Visible (Smooth)** works similar to interpolation **On Visible**, but generates a smooth surface.

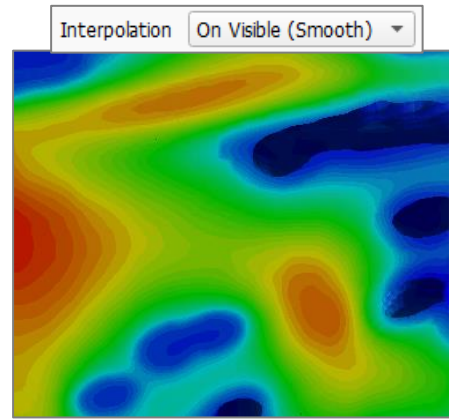
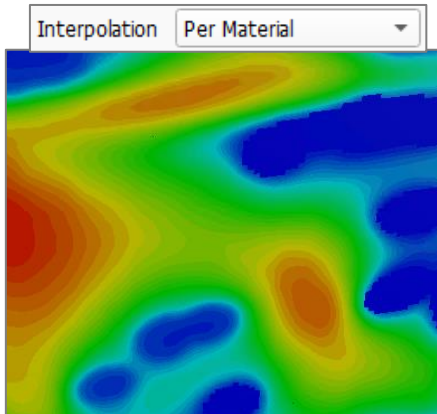

Select **Per Material** to linearly interpolate only within the materials to preserve sharp edges.

The **Threshold By** pull-down menu in the center panel of the **View Controls** and, the **Volume Field ▶ Visibility ▶ By Value** option in the **Visualization Settings** dialog, allows a clipping that is not related to the spatial coordinates but to the data range.

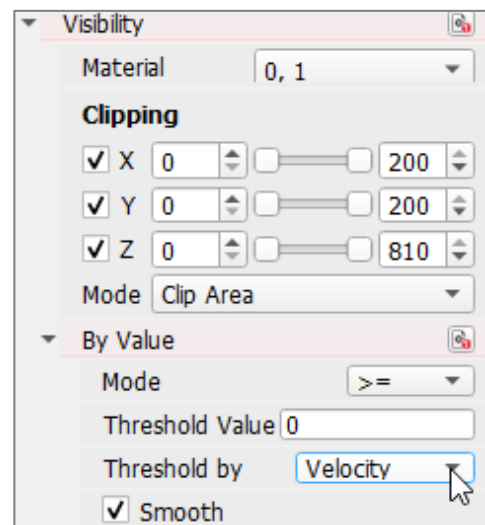
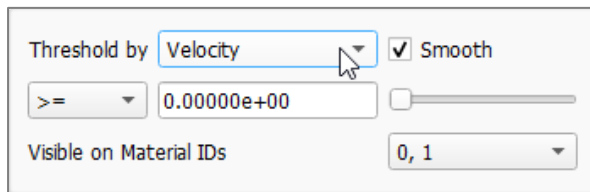

The **Threshold By** menu has the same options as **Color** (here VelocityX, VelocityY, VelocityZ, Velocity, and Pressure). For example, only flow velocities above 0.004 ($4 \cdot 10^{-3}$) m/s or then above 0.008 ($8 \cdot 10^{-3}$) m/s are visualized.

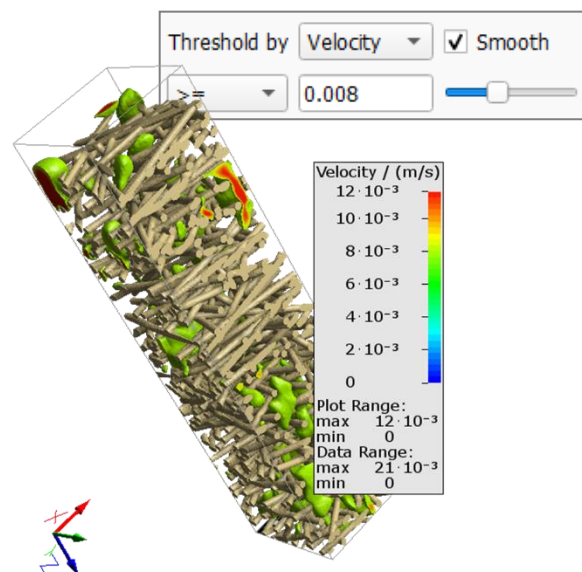
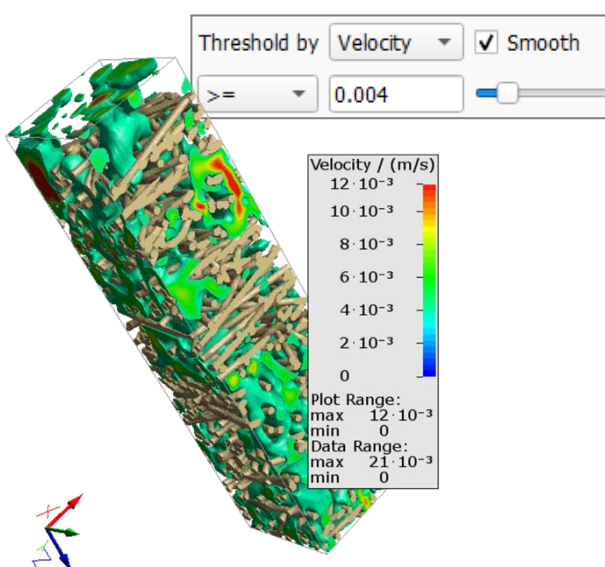

By default, the threshold **Mode** (or **By Value ▶ Mode**) displays velocities greater than or equal to the clipping value, but the user may choose, from the pull-down menu, to display only velocity values smaller than or equal to the clipping value or only values that are equal to the clipping value.

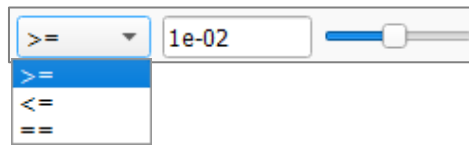

Unchecking **Smooth** voxelizes the surface of the volume field.

From the pull-down menu **Visible on Material IDs** select in which material IDs the volume field is visualized. If for example, a flow field is loaded, no flow happens in the solid materials, and thus they can be unchecked.

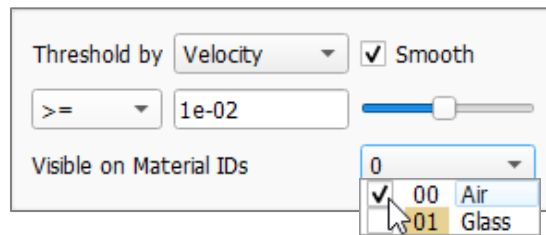

The displayed data can be spatially clipped in all three directions (**ClipX, ClipY, ClipZ**) with the sliders or by direct input. This facilitates the simultaneous visualization of e.g. structure model and flow field.

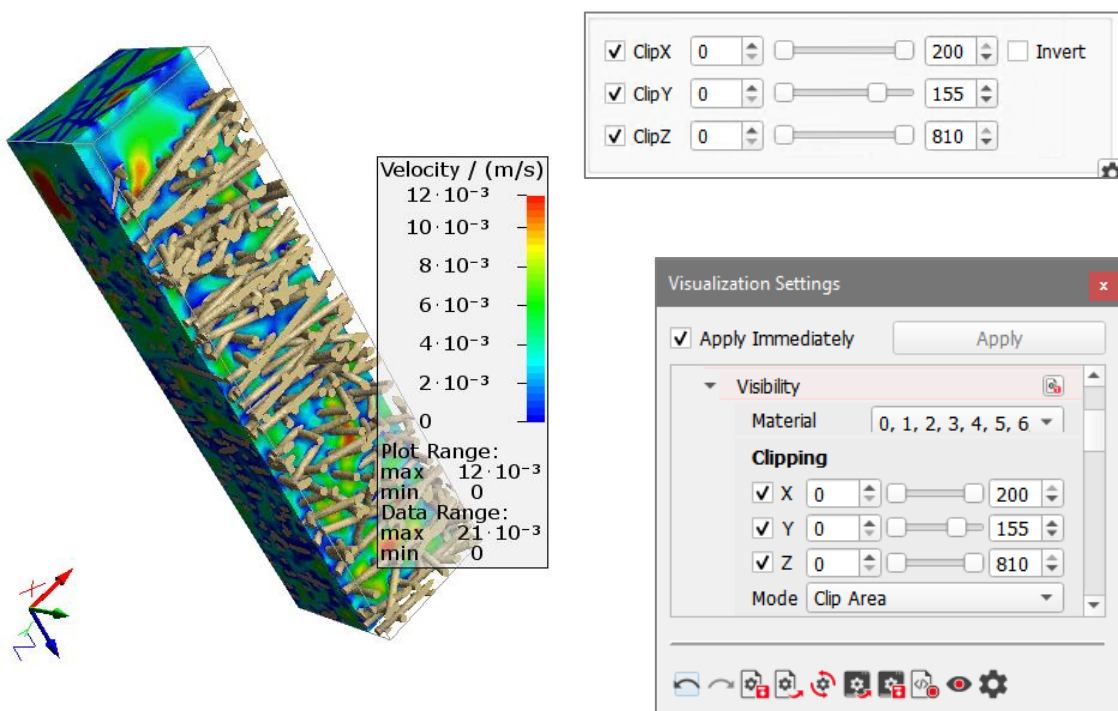

The **GPU** section, in the **Visualization Settings** dialog, offers additional visualization options using the graphics card instead of the main processor, when checking **Enabled**. The data needs to fit in the GPU memory to use this feature.

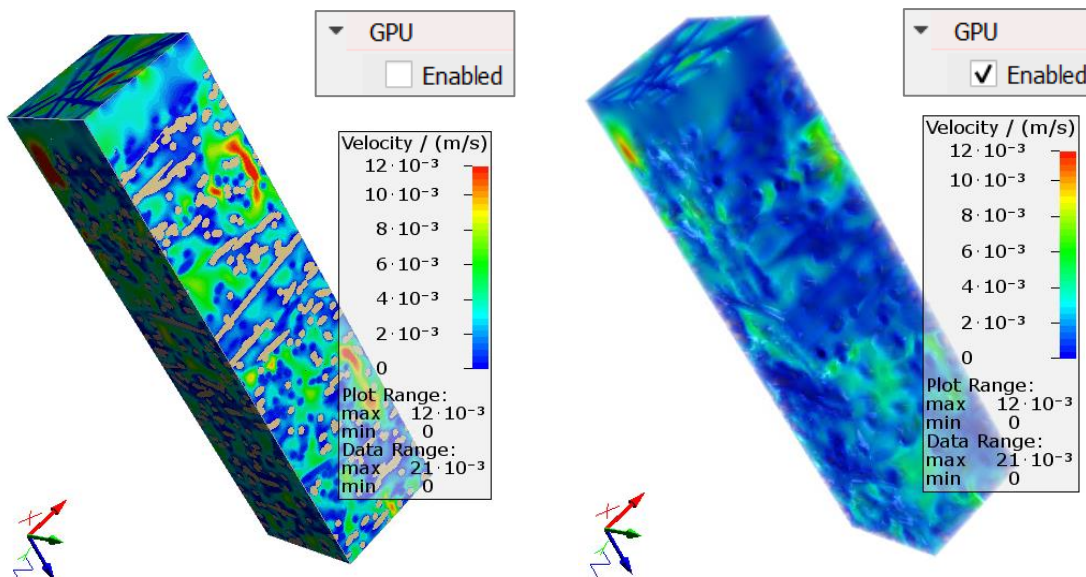
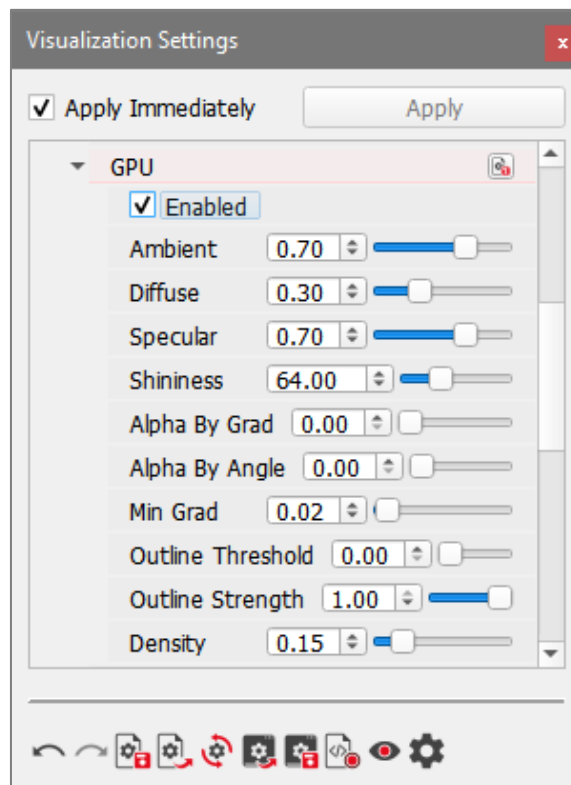

Control the amount of **Ambient** light, **Diffuse** scattered light and **Specular** mirror-like highlights, while determining the size of highlights with **Shininess**. These parameters correspond the [Phong Reflection Model](#), often used in 3D computer graphics. The light intensity controlled by them is independent of the light direction. Higher values for **Shininess** result in smaller highlights.

Alpha By Grad sets a focus to the edge regions. For high values only the edges are visible.

Alpha By Angle determines the visibility for the current camera angle. Higher values result in a more transparent volume field.

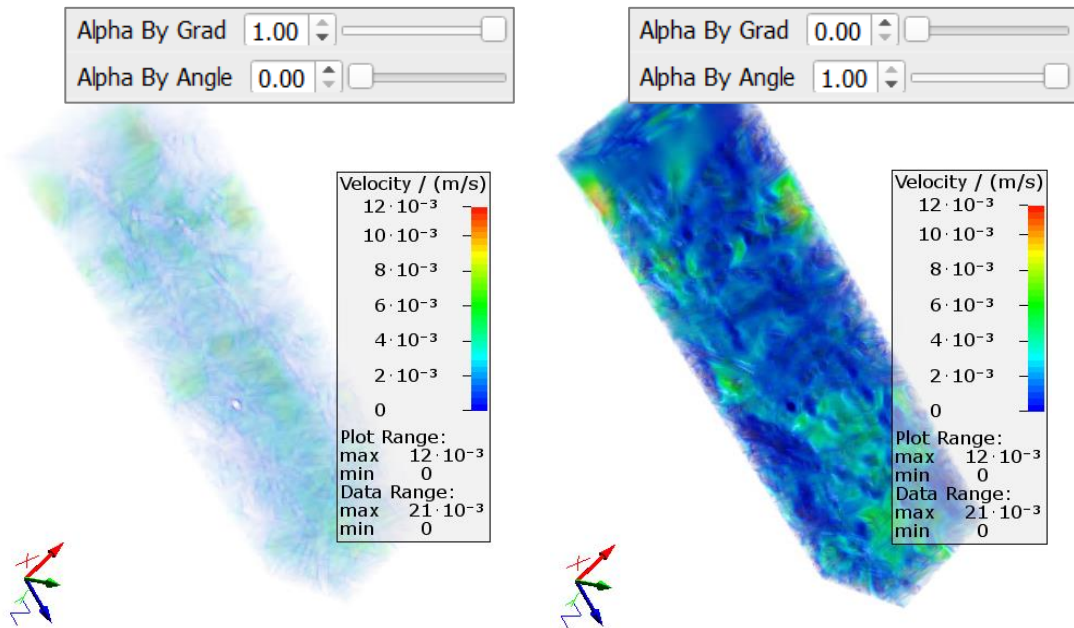

The shading is controlled by the **Min Grad** (minimal gradient magnitude). Higher values reduce clutter due to noisy data.

The parameters **Outline Threshold** and **Outline Strength** apply outlines to the volume field with the given threshold and strength.

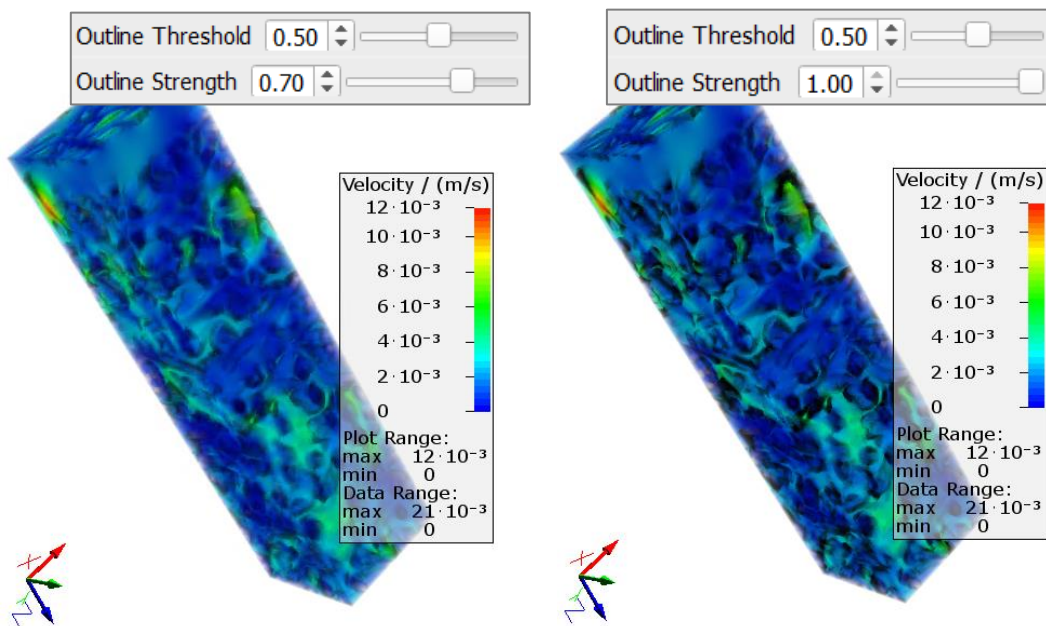

With the last parameter determine the overall **Density** of the volume field.

VISUALIZATION OF STREAMLINES, ARROWS, AND SCHLIEREN

As part of the visualization of the flow field, several GeoDict modules, e.g. FilterDict or FlowDict, can also display the streamlines left by the fluid when flowing through the structure, an arrow field for the flow, and the schlieren produced when the fluid flows through the structure (see Schlieren imaging for more info).

For these three visualization options, the complete vector field needs to be loaded. From the Result Viewer load the result field from the **Visualization** tab, here **Particle Visualization**. For a FilterDict result click **Load Flow Field** and select **VelocityX**, **VelocityY**, **VelocityZ**, and **Velocity** as components of the flow field to be loaded.

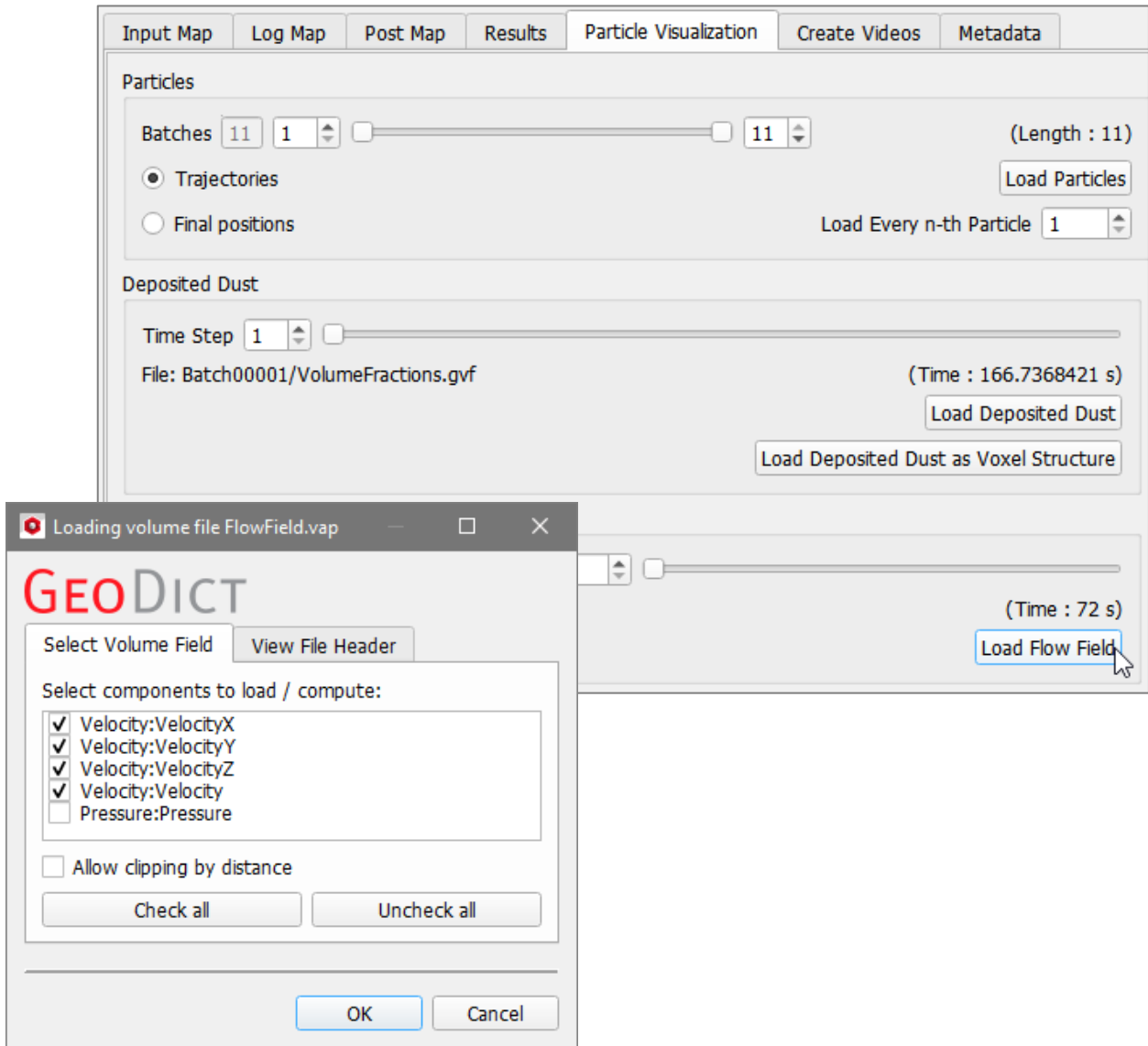

The initial default visualization after loading can be optimized by modifying the parameters under the **Streamlines**, the **Arrows**, or the **Schlieren** tabs in the **View Controls**, above the Visualization area.

Check these tabs to make their options selectable. At the same time, to only visualize the selected fields, turn off the visualization of the flow field by unchecking the **Volume Field** tab. If needed, also switch off the display of the structure model (**Structure**), as indicated in page 47.

This can also be done through the **View** menu as follows:

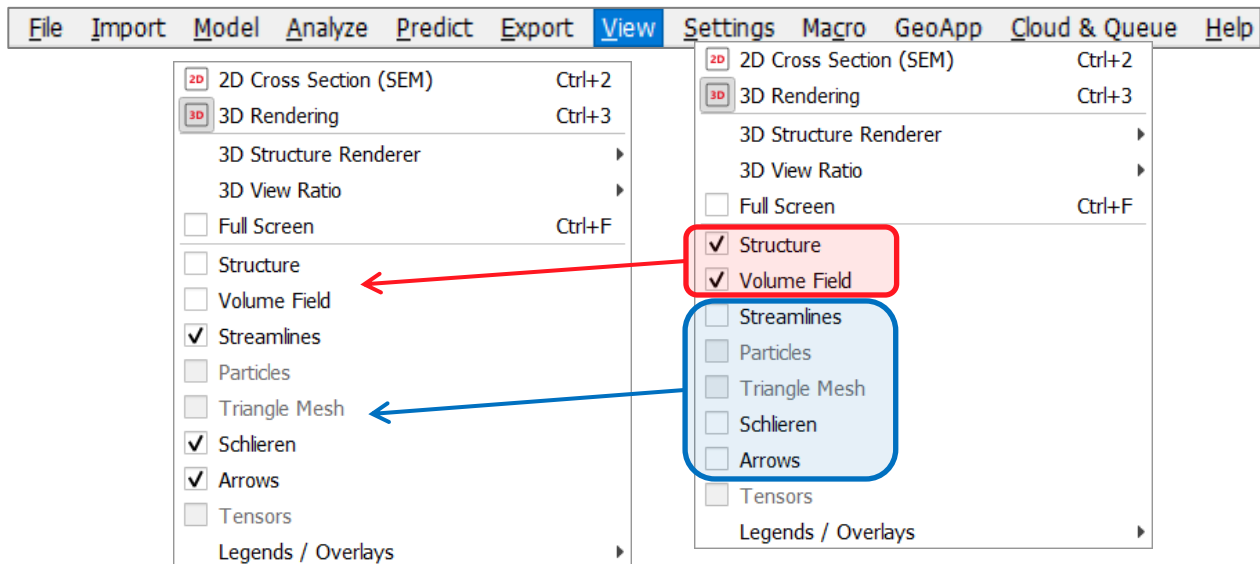

Or through the **Visualization Settings** dialog, as follows:

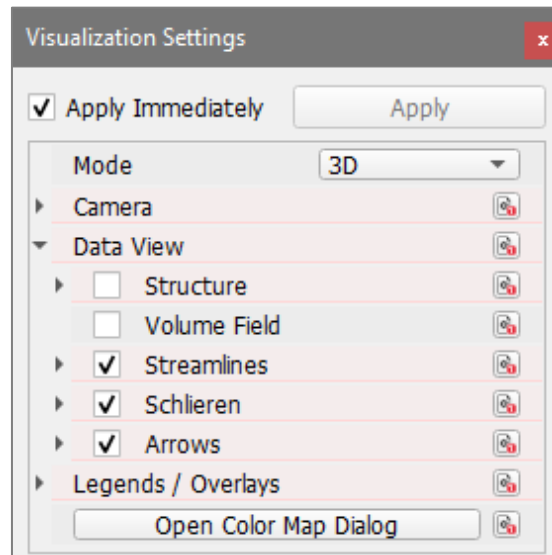

As soon as the **Arrows**, the **Streamlines**, or **Schlieren** are checked, they are loaded into the Visualization area, and the parameters needed to set their visualization can be modified.

For beautiful visualizations, also more fields can be visualized at once, for example by clipping them in parts, as described on page [67](#), or if the volume field is turned on, enable **Transparency** in the **Volume Field** tab and adjust the transparency settings in the **Color Map** dialog, as described starting on page [34](#). In the image on the right, the structure is clipped halfway in X-direction, the volume field is set to transparent, and the streamlines are enabled.

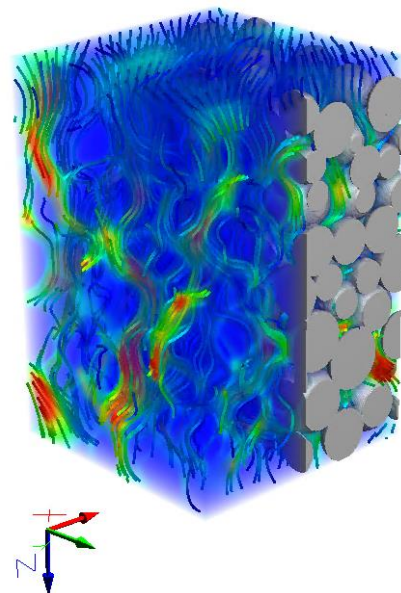

Visualization of Streamlines

To see the streamlines, check only **View** → **Streamlines** in the menu bar, the **Streamlines** tab in the **View Controls**, or **Data View** ► **Streamlines** in the **Visualization Settings** dialog.

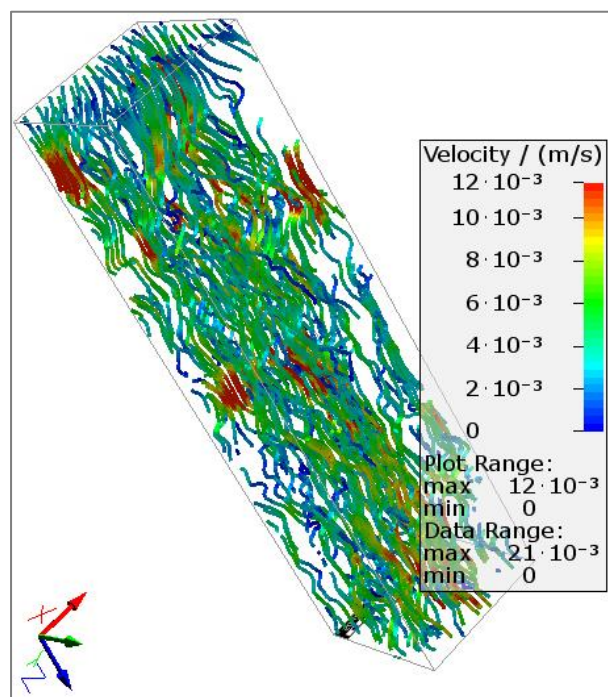
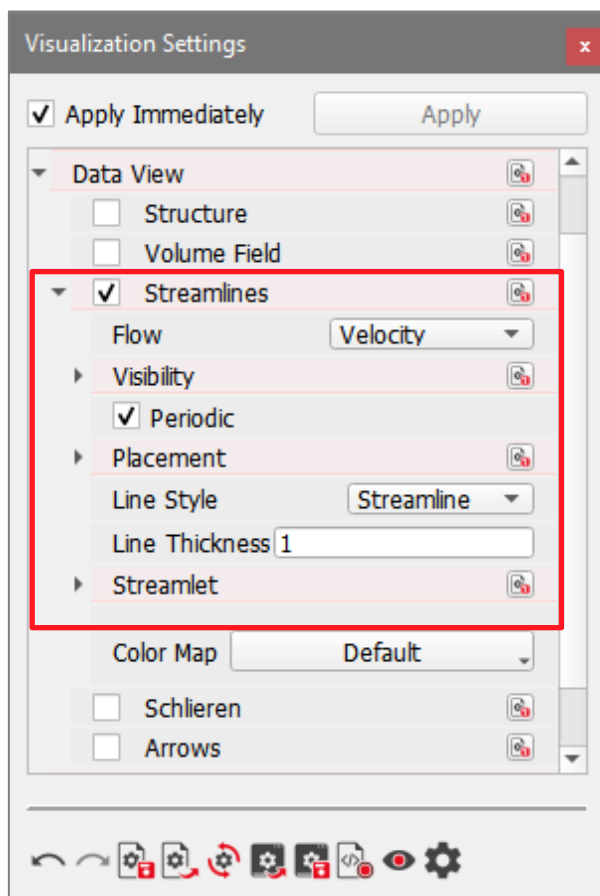
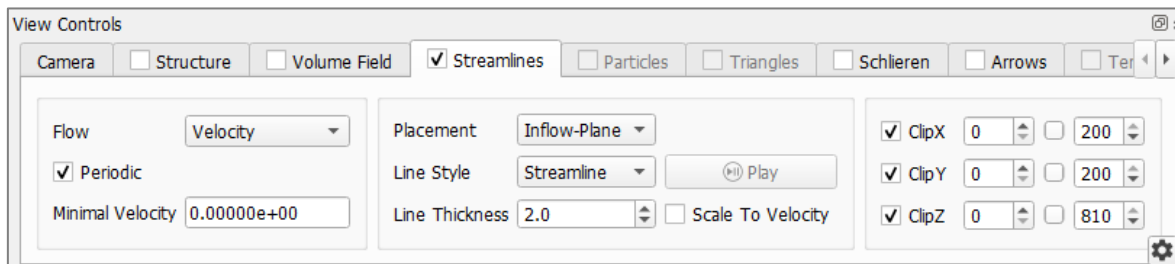

The **Flow** pull-down menu shows **Velocity** as the only choice.

The color coding of the streamlines is based on the fluid flow results for **VelocityX**, **VelocityY**, **VelocityZ**, and **Velocity**.

Checking **Periodic** enables periodic boundaries for the display of the streamlines, i.e. the streamlines exiting the tangential domain boundaries are reentering the domain periodically.

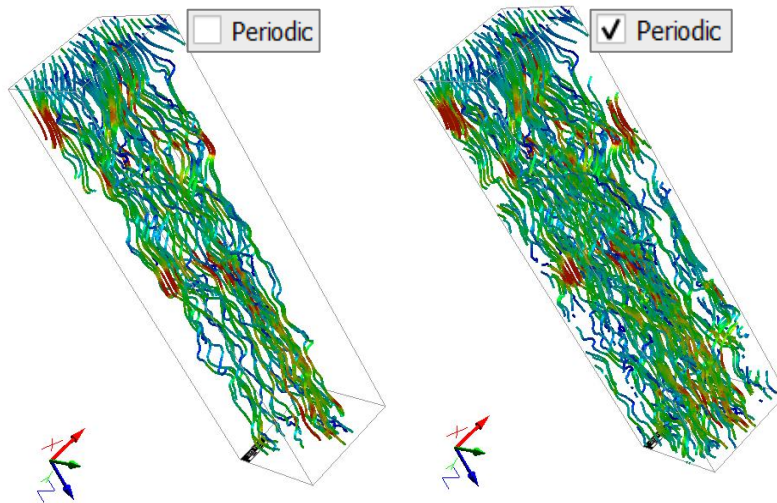

The choices in **Line Style** are **Streamlines**, **Streamlets**, and **Streamtubes**. The thickness for each line style is controlled through **Line Thickness**.

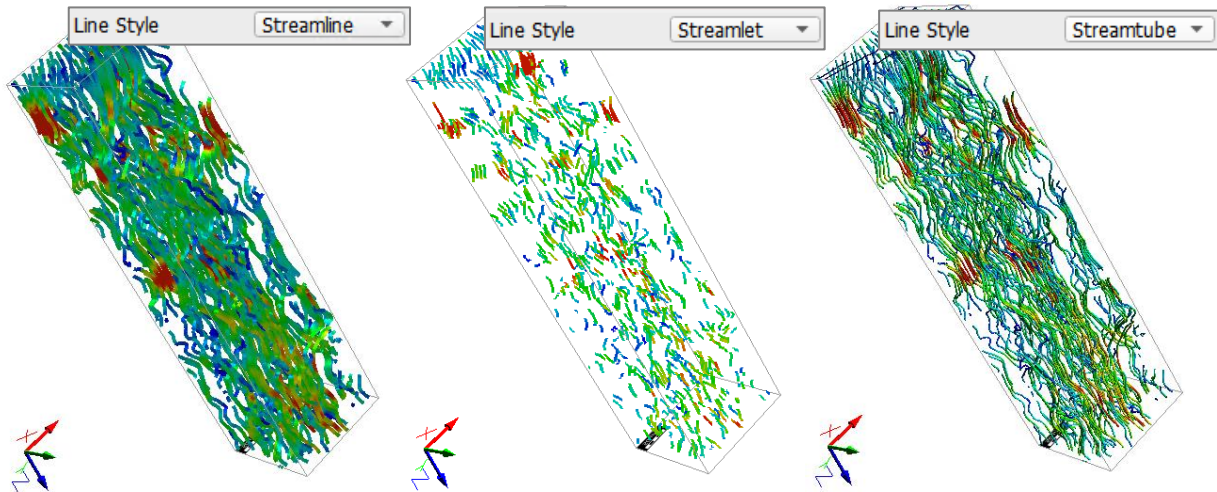

Choosing **Streamlets** activates the visualization of the streamlines as streamlets, a visualization in which a streamline is fragmented into segments.

The movement of these segments along the streamline is visualized and can be animated by clicking **Play**. The animation is repeated in an infinite loop until **Play** is clicked again.

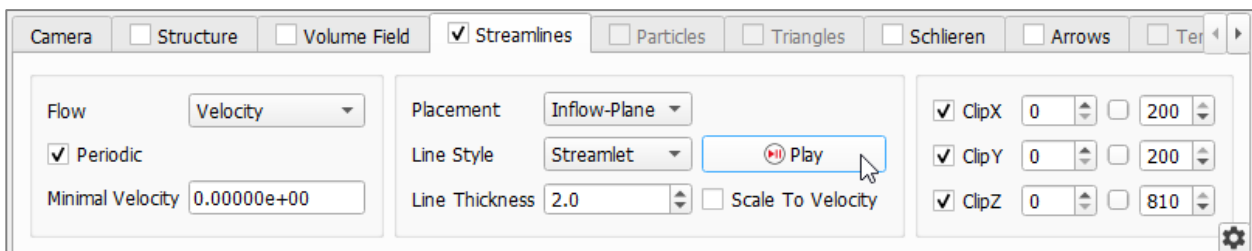

The visualization and animation of streamlets is controlled by four options in the **Visualization Settings** dialog:

- **Number of Streamlets** defines the number of segments that represent a streamline. The larger the number, the easier it becomes to identify the complete streamlines.
- The streamlet **Length** determines the fraction of each streamline that is displayed. In combination with the number of Streamlets per Streamline, it defines the length

of the streamlets. The larger the number, the lower the distance between the streamlets. For a length of 1, the streamlets connect to complete streamlines.

- The **Number of Frames** controls the speed of the animation by specifying the number of frames that are to be visualized when clicking **Play**. Small numbers produce fast and short animations. Large numbers produce slow animations, with more frames.
- The **Current Frame** is updated automatically, when stopping the animation. While no animation is played, any frame between 0 and the entered **Number of Frames** can be visualized.

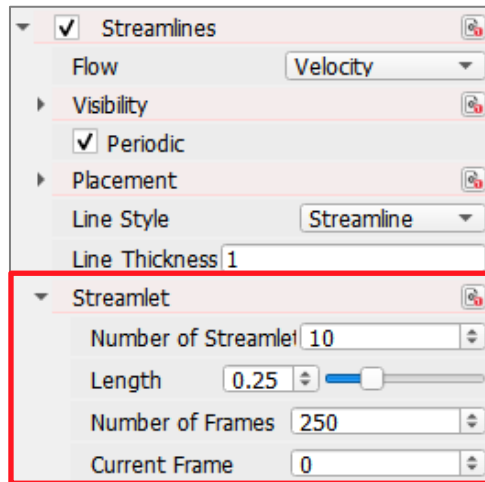

The setting **Scale to Velocity** also affects the visualization of streamlines and streamlets and is coupled with **Minimal Velocity**. This is a clipping tool based on the velocity of the fluid. In this case, streamlines and streamlets with a velocity lower than the specified **Minimal Velocity** are not shown in the visualization.

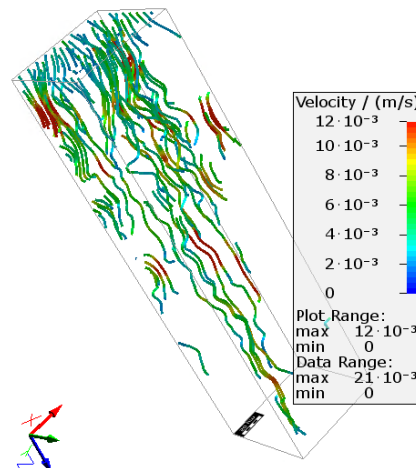
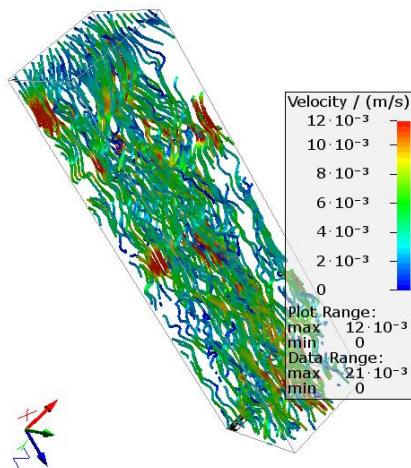
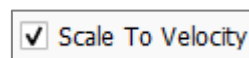
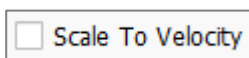
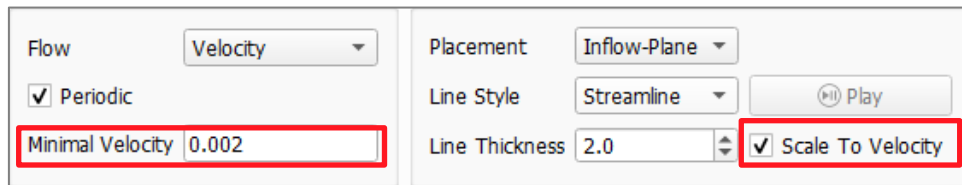

When **Streamlets** is chosen, **Scale to Velocity** additionally adjusts the movement of the streamlets in relation to the maximum velocity of the flow field. As a result, the streamlets move with individual velocities and not with a uniform speed, as they would do without a scaled velocity.

In the **Visualization Settings** dialog the option is found under **Data View ► Streamlines ► Visibility**.

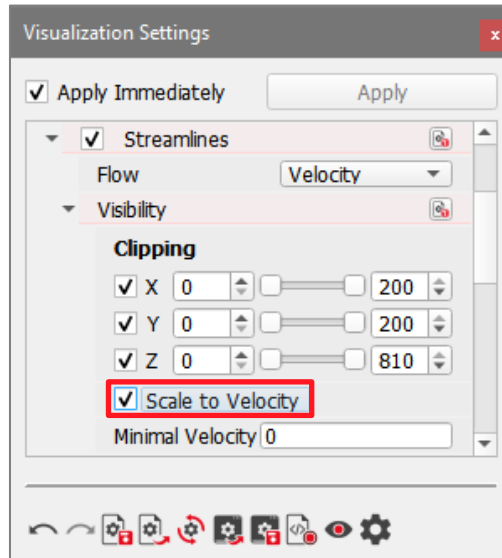

The choices for **Placement** define from where the streamlines, streamlets, or streamtubes are calculated.

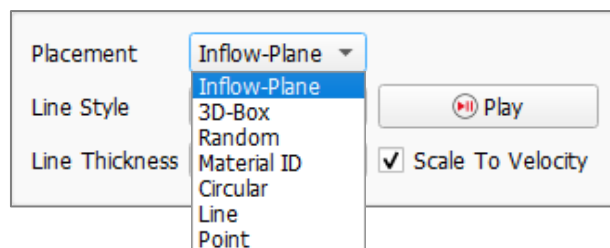

Select the streamline starting positions from the pull-down menu for **Placement** (or **Placement ► Type**). Either the starting points (or seeds) for the calculation are placed at the **Inflow-Plane**, in a grid in the 3D-domain (**3D-Box**), randomly distributed in the entire domain (**Random**), in one of the materials (**Material ID**), inside of a circle (**Circular**), along a line (**Line**), or at a given point for a single streamline (**Point**).

Choosing any of them gives options for their display, as seen here on the left for the **Inflow-Plane Placement**.

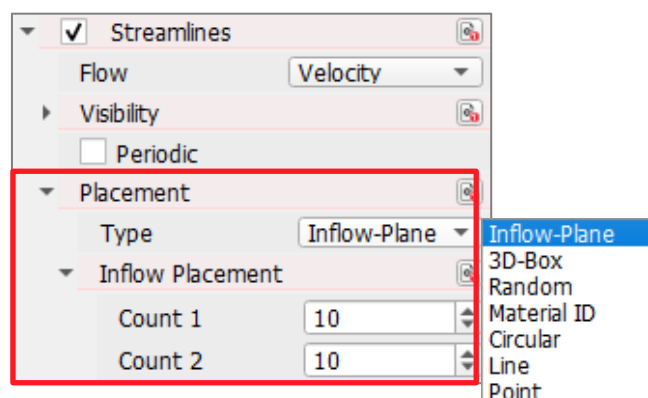

Selecting **Inflow-Plane** distributes the starting positions on the flow field inflow plane. In flow fields, this plane is determined by the flow direction. If for example, the flow is computed in Z-direction, the inflow plane is the XY-plane. Then, **Count 1** and **Count 2** define a grid in the inflow plane. Increasing the number, increases the number of streamlines in the respective direction.

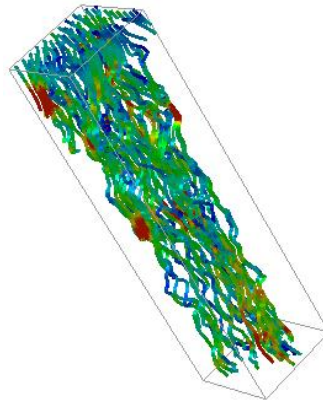

Selecting **3D-Box** for **Placement Type** defines a three-dimensional box with corners (**Start 0, Start 1, Start 2**) and (**End 0, End 1, End 2**). Inside this box **Count X x Count Y x Count Z** streamlines are placed regularly.

Placement	
Type	3D-Box
Box Placement	
Position	
Start X	50
Start Y	50
Start Z	50
End X	150
End Y	150
End Z	150
Count X	5
Count Y	5
Count Z	5

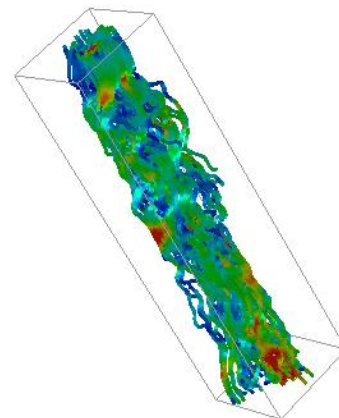

To distribute the starting positions randomly, select **Random**. For **Random Placement** choose a value for **Count**, controlling the number of starting positions for the streamlines.

Placement	
Type	Random
Random Placement	
Count	1000

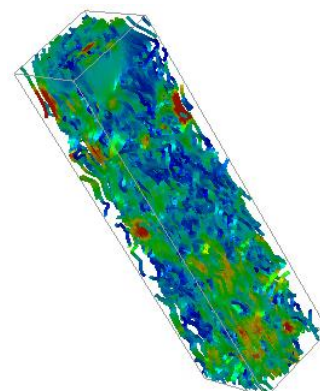

Choosing **Material ID** places seeding positions only inside voxels of the selected material **ID**. **Max Count** defines the number of starting positions for streamlines. The seeding points are all placed at voxel center positions. If there are less voxels of the material ID present, than given for **Max Count**, less streamlines are visualized.

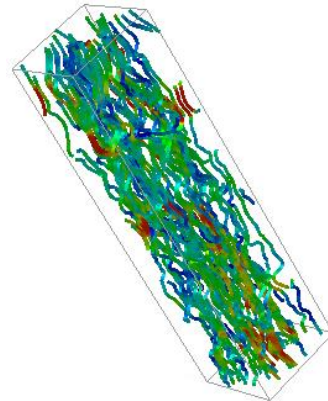
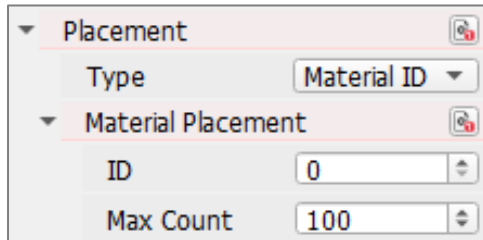

Select **Circular** to place the streamline starting positions on circles around the defined **Midpoint**. The **Direction** then defines an axis through the **Midpoint** on which the circles are placed. Define the **Radius** for all these circles. The number of circles is controlled with the value entered for **Repeat**. The distance between the streamline starting positions on the circles is defined by **Density**.

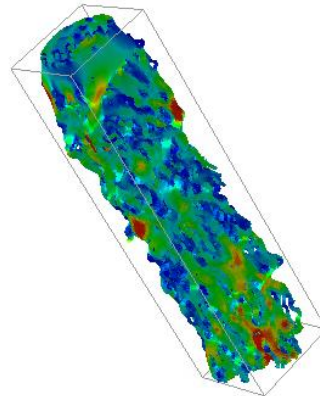
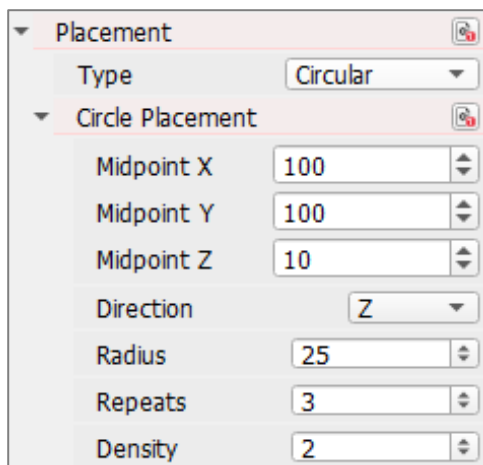

The placement type **Line** places the starting positions on a line from (**Start 0, Start 1, Start 2**) to (**End 0, End 1, End 2**). The value for **Count** controls the number of streamline starting positions.

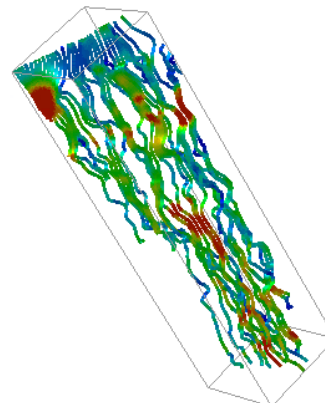
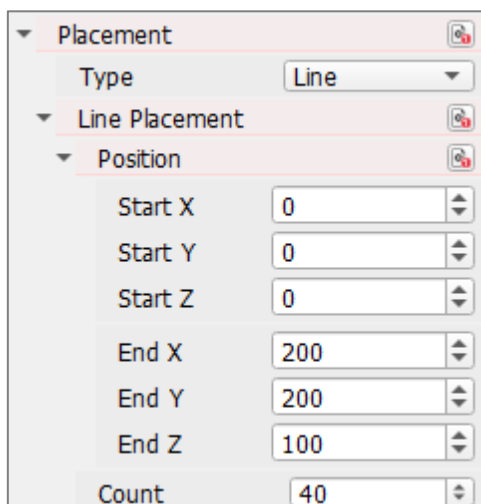

Select the placement type **Point** to place a single streamline at the starting position defined by **Position 0**, **Position 1**, and **Position 2**.

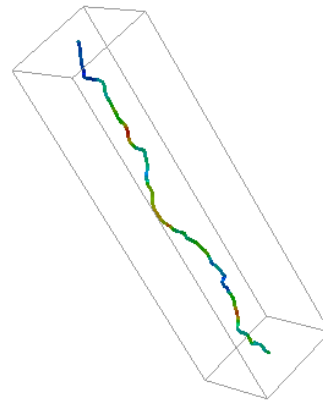
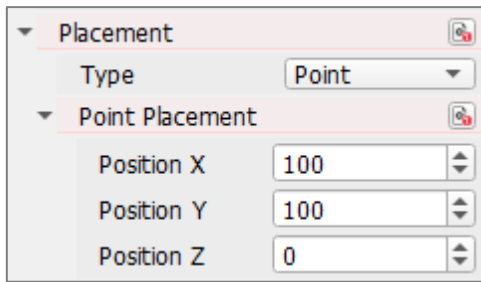

The placement only defines the starting positions. If a streamline starts in, or quickly runs into a solid structure voxel, the streamline has a length of 0 and is invisible.

When there is flow through the entire domain, entering on one side, leaving on the opposite side, the **Inflow-Plane** option is preferable. For a flow, which starts somewhere in the domain, such as Lithium-flow in a battery simulation, either **3D-Box** or **Random** are appropriate.

The streamlines, streamlets, and streamtubes cannot only be clipped according to their velocity but also conforming to their spatial position, in a similar way as explained above for the display of the **Volume Field** (page 67).

It is possible to define the range of voxels in each spatial direction that are to be displayed by moving the slider or by direct input of the value.

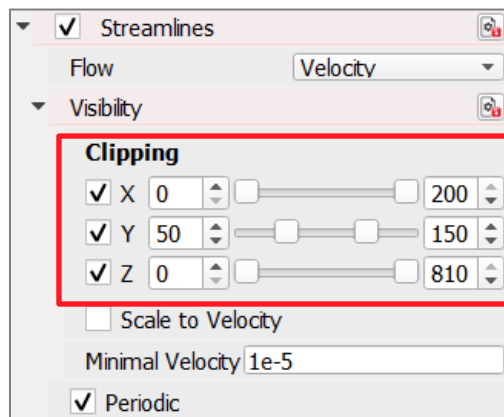

Visualization of Arrows

Another flow field visualization option is representing the volume field by an arrow field.

Here, the properties of the fluid flow field are imaged at all positions of a regular grid that do not belong to the solid. At each of these positions, the local orientation of the flow field is indicated by a vector and its length and color are coded for the fluid velocity.

Small vectors indicate a slow fluid velocity and long vectors indicate a high fluid velocity. Vectors are located with their middle in the center of the voxel for which

they represent the flow velocity.

To see the arrows, check only **View** →

Arrows in the menu bar, the **Arrows** tab in the **View Controls**, or **Data View ▶ Arrows** in the **Visualization Settings** dialog.

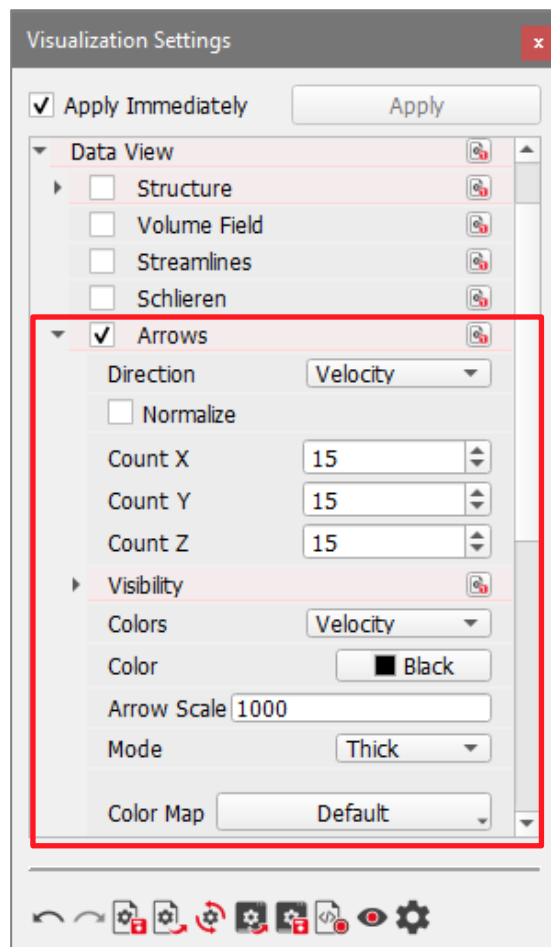
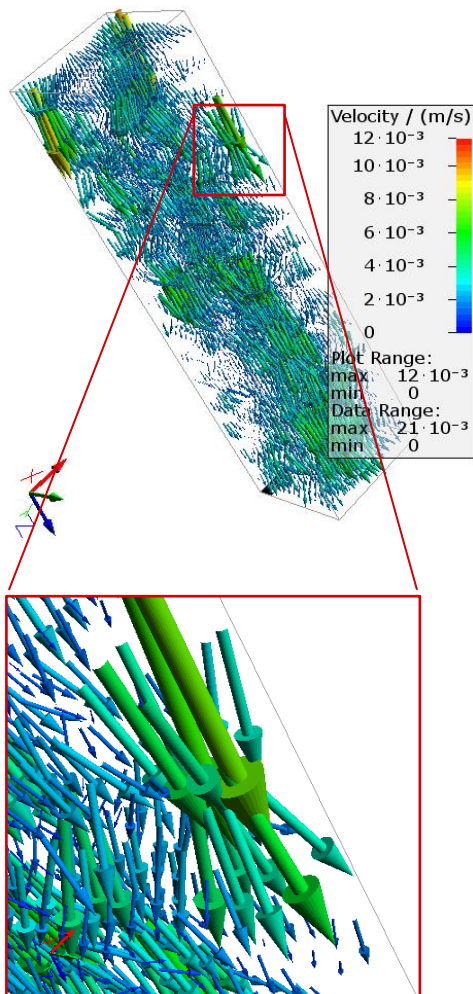
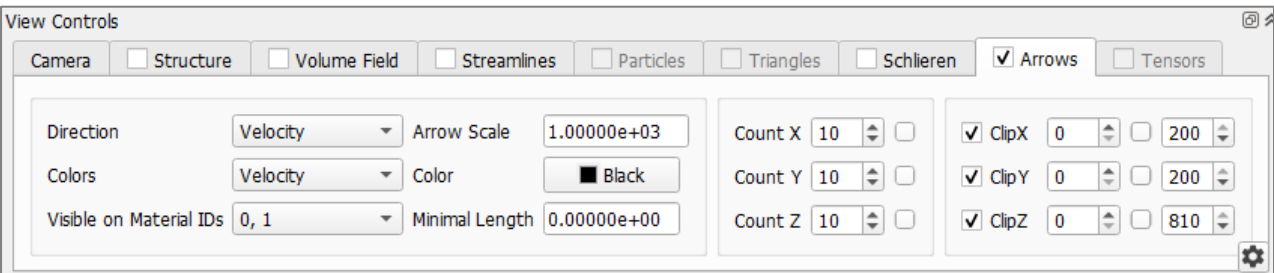

The **Colors** pull-down menu applies these properties to the vectors resulting from the simulation. **Colors** are determined by the velocity of the flow at the corresponding position. **Colors** can be assigned all previously chosen components, whereas the **Direction Field** is fixed to Velocity.

Visible on Material IDs defines the material IDs in which the arrow field is shown. This allows to visualize the flow also in porous media where fluid flow is computed according to the Stokes-Brinkman equations (porous voxels / solid voxels / pores). Several material IDs can be selected at the same time.

The **Arrow Scale** scales the size of the arrows as a percentage of the maximum dimension (here, velocity).

If **Colors** is turned **off**, a custom **Color** can be applied to all arrows by clicking on the color button.

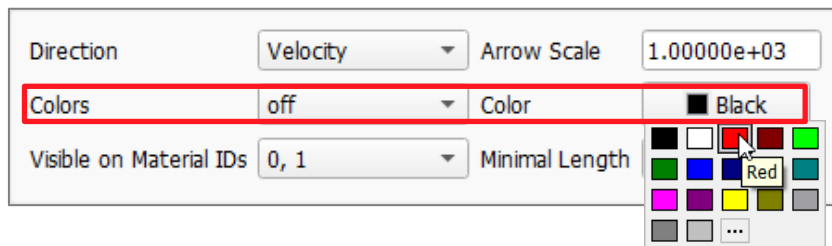

Minimal Length sets the minimum length used for the slowest arrow, before scaling. The values are limited to those between the maximum and the minimum in the **Plot Range** (here, between 0.00 and 0.012 m/s).

Count X, **Count Y**, and **Count Z** define the number of arrows for each axis.

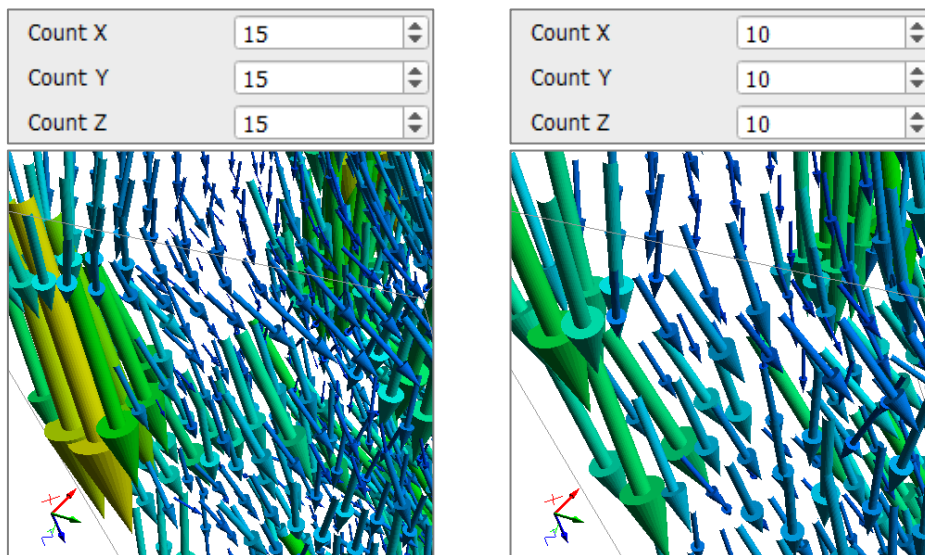

Clipping works in the same way as seen in page 67 for the clipping of the flow field and streamlines.

Distance To Structure defines a space around the solid structure model that is to remain void of arrows. If enabled, **Distance To Structure Range 0** and **Distance To Structure Range 1** give the range of distance where the vectors are shown (in voxels).

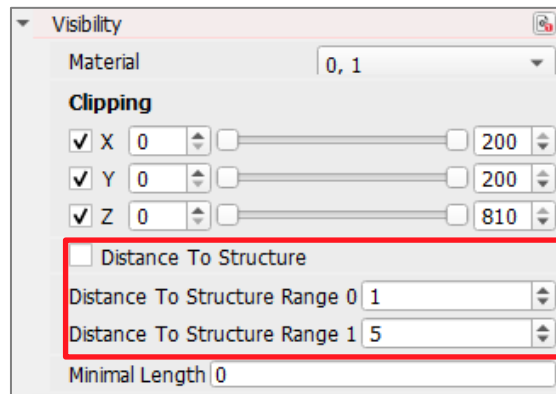

Checking **Normalize** visualizes all arrows in the same size.



Mode changes the display of the arrows to appear as a **Line** or **Thick**.

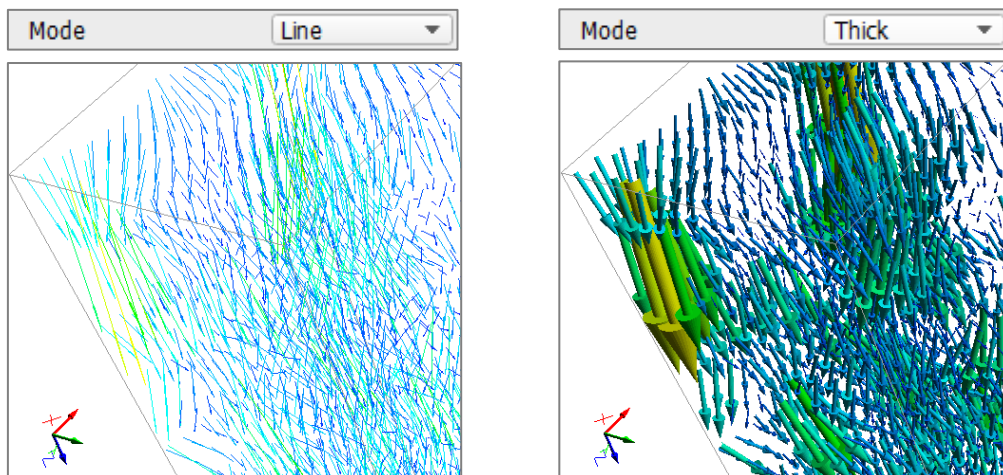

Visualization of Schlieren - Line Integral Convolution (LIC)

Schlieren is the third option to visualize the fluid flow field provided in FlowDict, AddiDict and FilterDict. LICs are visually displayed as distorted striations or streaks in 2D sections that represent fluid motion through the 3D flow field, in any of the three directions. Schlieren are only available in 3D Rendering.

To observe the schlieren, check only **View** → **Schlieren** in the menu bar, the **Schlieren** tab in the **View Controls**, or **Data View** ► **Schlieren** in the Visualization Settings dialog.

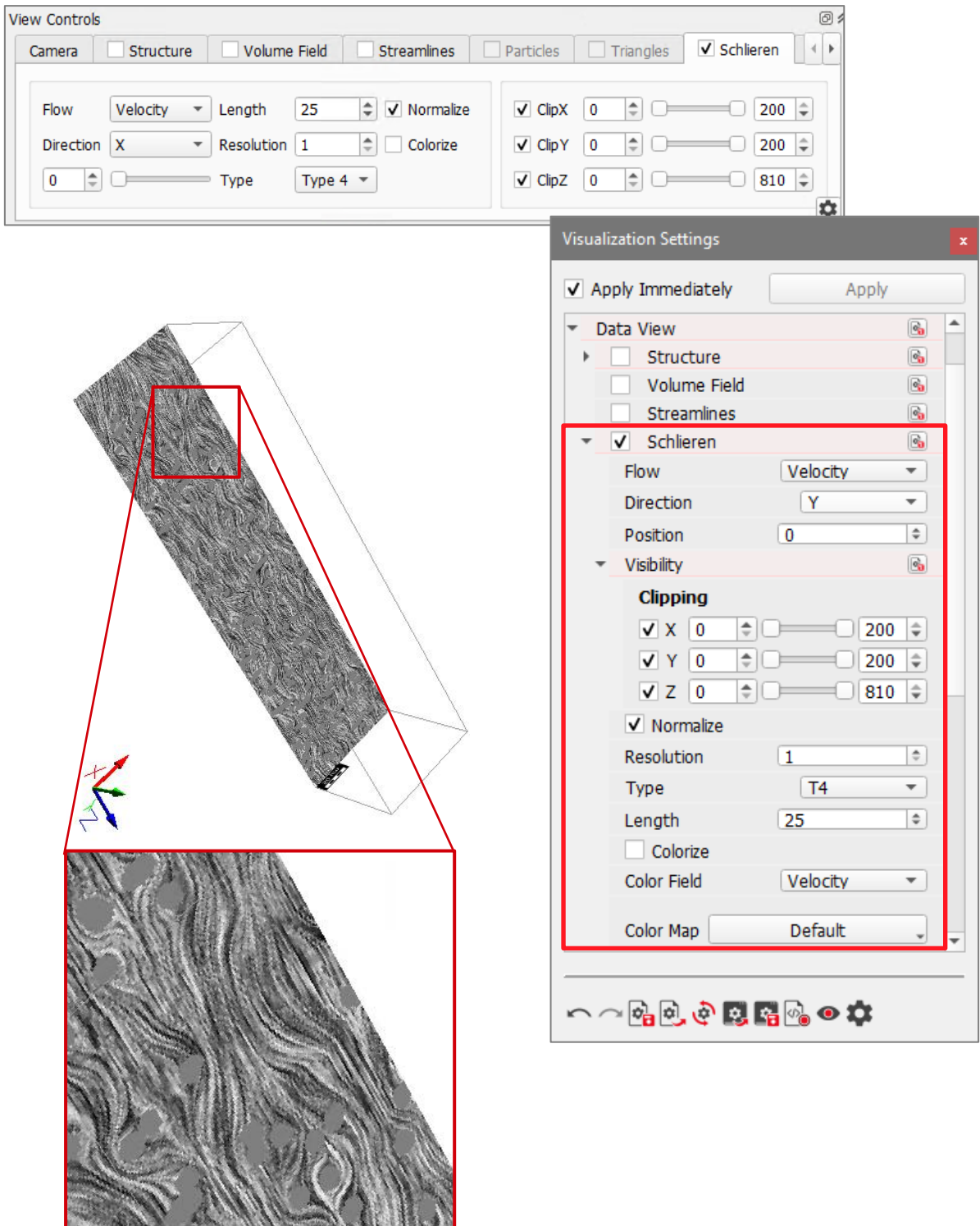

For **Flow**, only **Velocity** is available, as the Schlieren are computed from this flow field.

Direction defines the location of the schlieren 2D section in the three directions. For example, to examine the schlieren along the Z-direction, change the **Position** value as indicated:

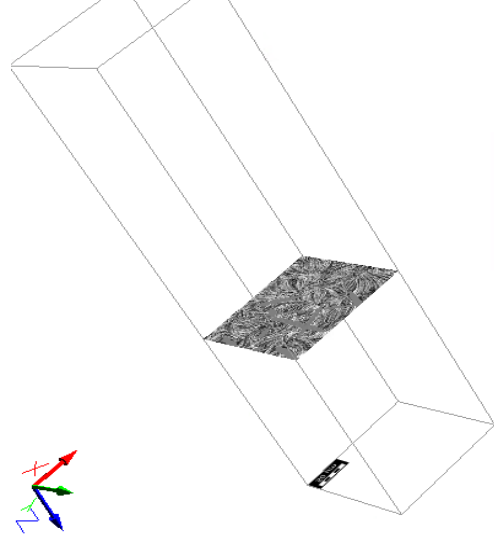
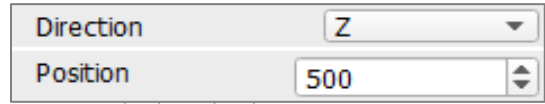
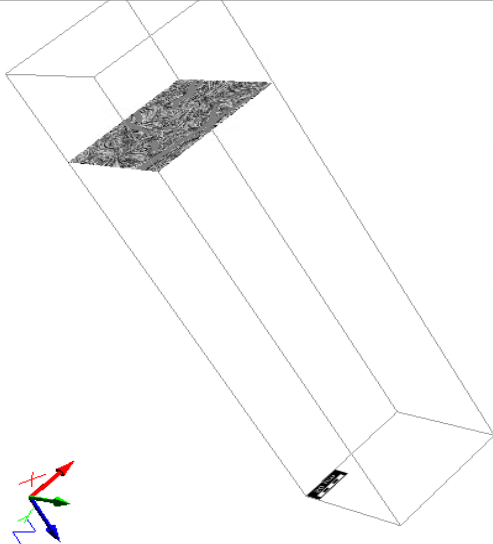
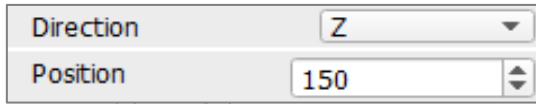

Clipping works in the same way as seen in page [67](#) for the flow field, streamlines, and arrows.

Checking **Normalize** activates the normalization of the visualization in relation to the maximum fluid velocity.

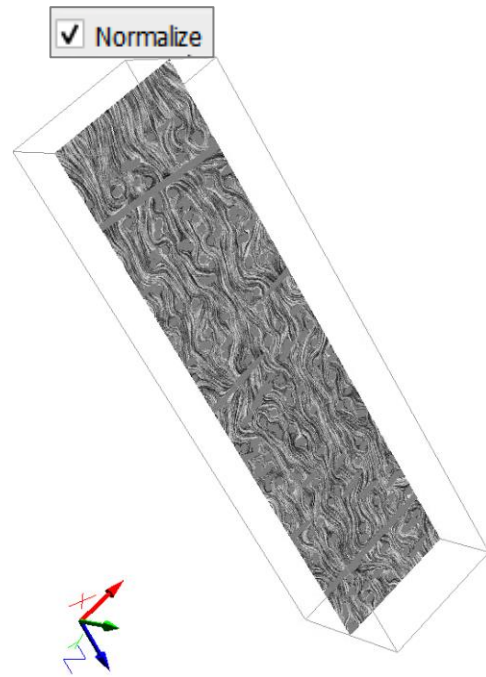
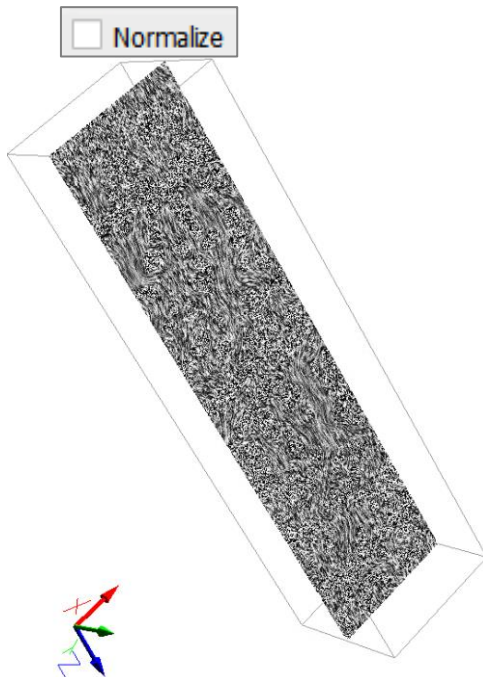

Resolution specifies the number of pixels in one spatial direction that represent the related voxel.

Type allows predefined post-processing of the schlieren by choosing from the pull-down menu. **Type 0** displays the original LIC and **Type 1** to **Type 4** each applies a different sharpening filter to the original LIC.

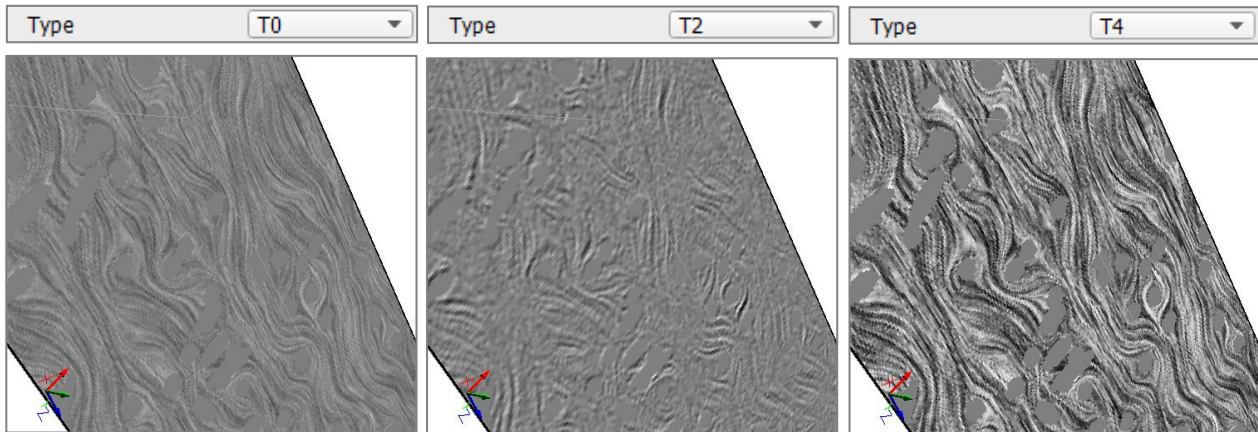

Length defines the elongation of the individual LIC lines.

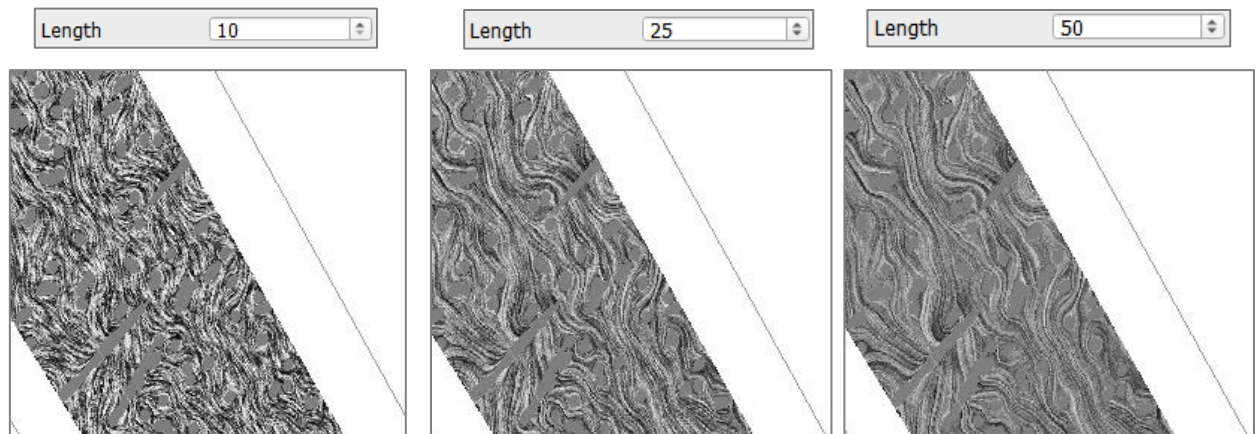

Colorize defines whether the schlieren are displayed in gray scales or in color. The color then can be selected from the flow fields, available in the pull-down menu for **Color Field**.

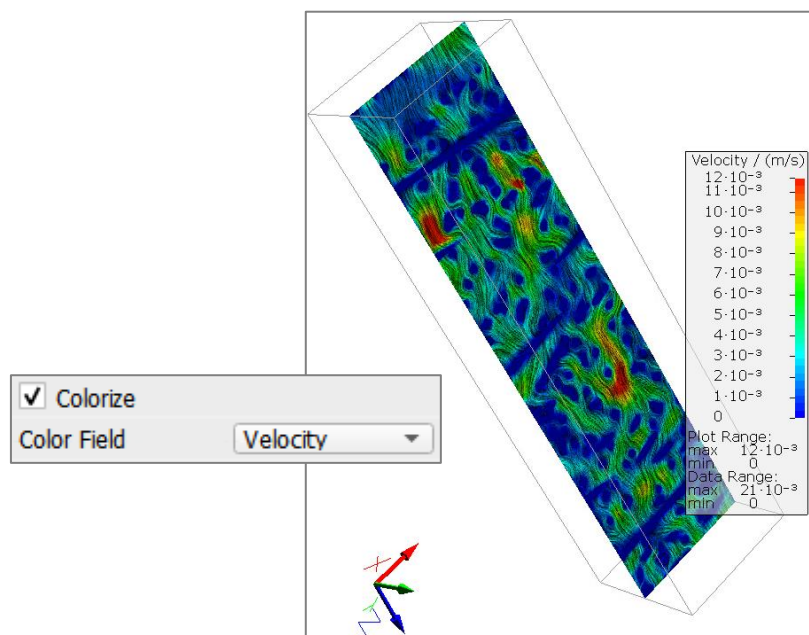

TENSORS

To visualize the **Tensors**, a result field containing tensors must be loaded. Here, a **Flexural Test** was simulated on a fiber structure with **ElastoDict**.

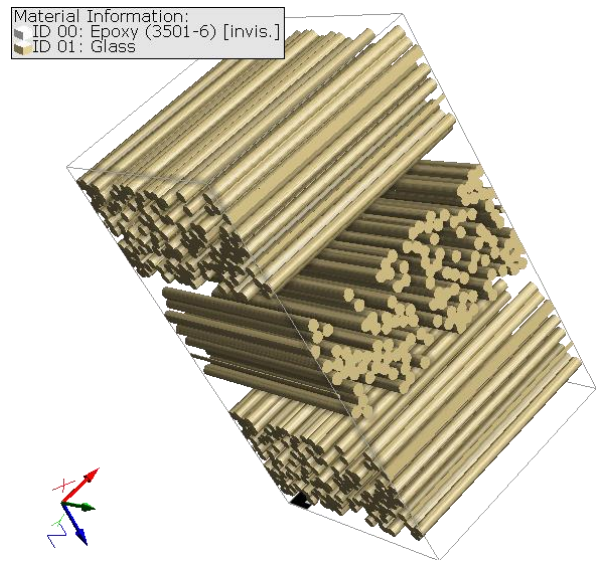

In the Result Viewer of the result file, under the **Strain/Stress Visualization** tab, in the **Flow Field** panel, select a **Time Step** and click **Load**.

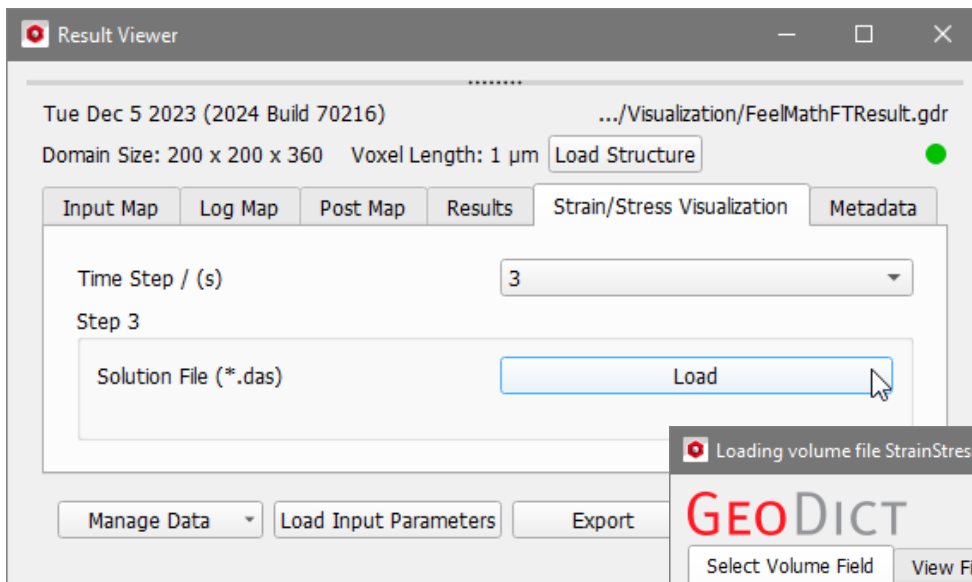

In the **Loading volume file StrainStressResult.das** dialog, the complete vector field needs to be loaded. Either all Strain components and / or all Stress components. Click **OK**.

The structure model and the volume field are shown in the Visualization area in 3D Rendering.

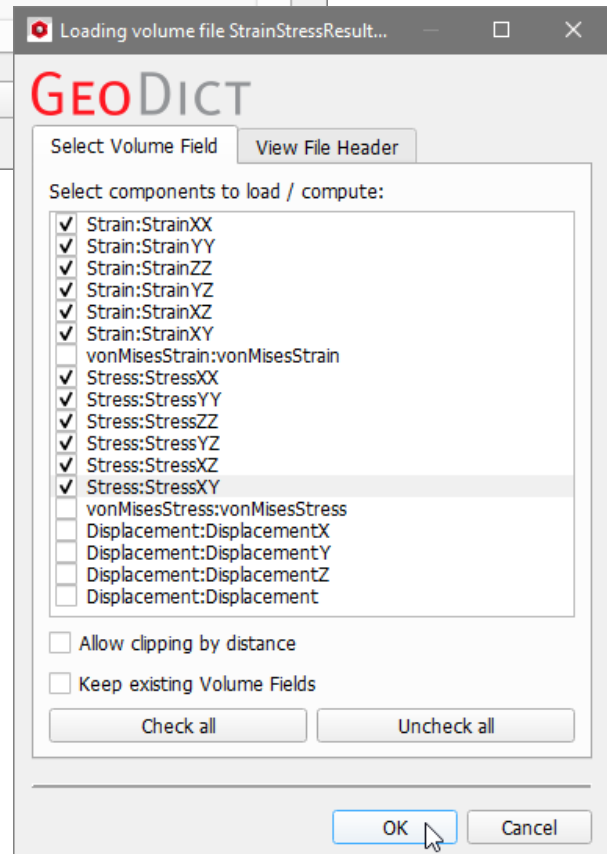

To see the tensors, check only **View** → **Tensors** in the menu bar, the **Tensors** tab in the **View Controls**, or **Data View** ► **Tensors** in the **Visualization Settings** dialog.

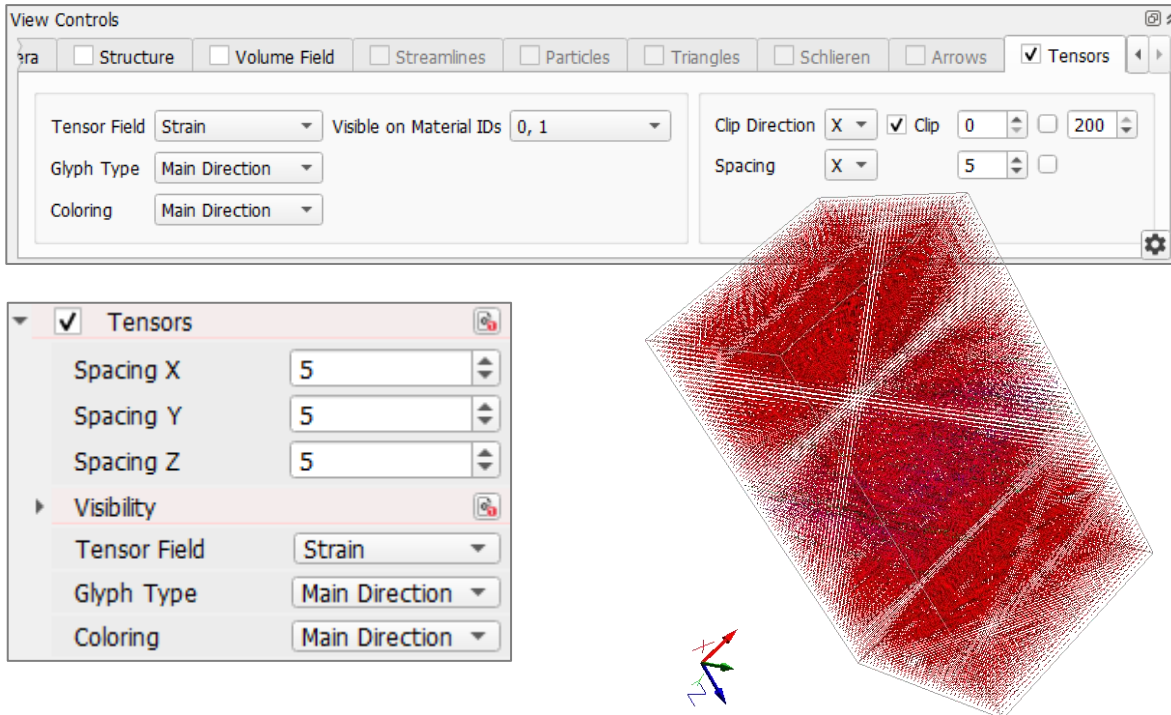

Select, if the **Tensor Field** should be displayed for **Strain** or **Stress**.

The **Glyph Type** can be set to **Box**, **Ellipsoid**, **Main Direction** or **Super Quadric**.

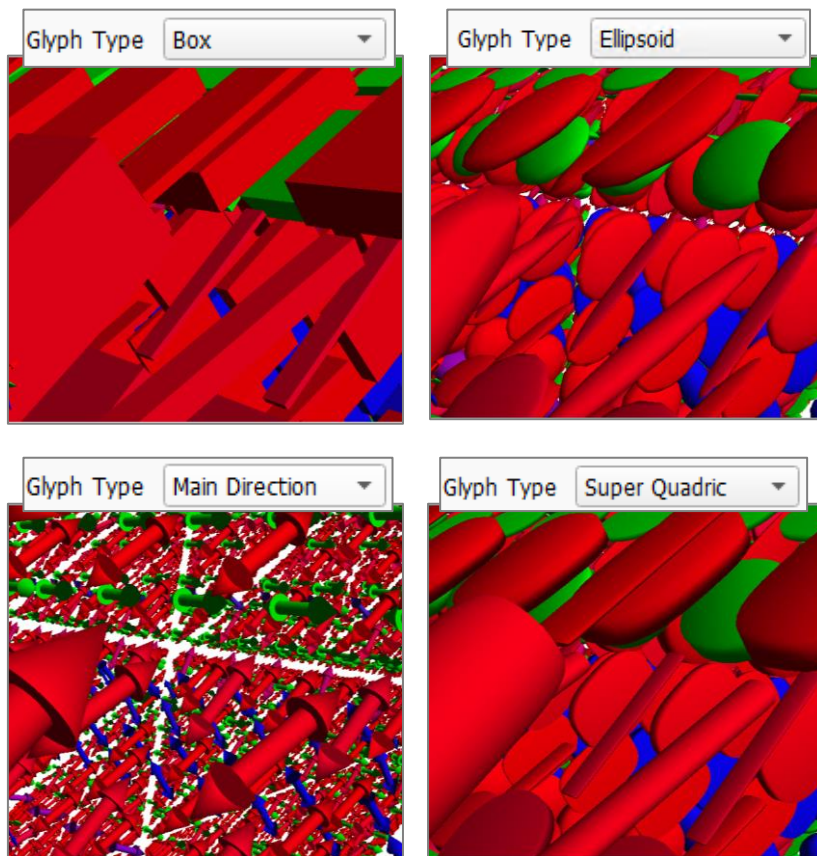

The **Coloring** can either be set to **Main Direction** or **Shape**.

For **Main Direction**, the main eigenvector is interpreted as RGB, i.e. red, green and blue. An eigenvector for strain or stress is the direction (x,y,z) of the largest principal strain the largest principal stress, respectively. If the vector is pointing in X-direction, the color is red, if it is pointing in Y-direction, the color is green and for the Z-direction it is blue. For everything in between, the colors are interpolated.

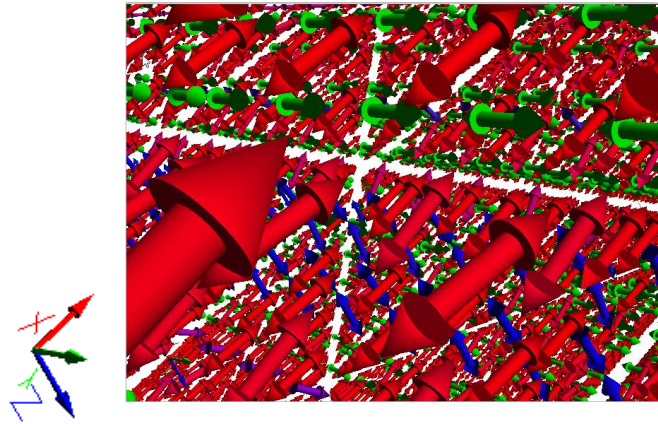

For **Shape**, the color depicts the shape of the tensor, i.e. the color depends on whether the tensor is mainly linear, planar, or spherical. If the shape is mostly linear, the color is red, if it is mostly planar, the color is green, and if it is mostly spherical, the color is blue. The figure below (see also [1]) shows how the certainties (c) for the tensor shape are computed based on the non-negative eigenvalues $\lambda_1 \geq \lambda_2 \geq \lambda_3$ of the tensor. For strain and stress, the three eigenvalues are the three principal strains or stresses.

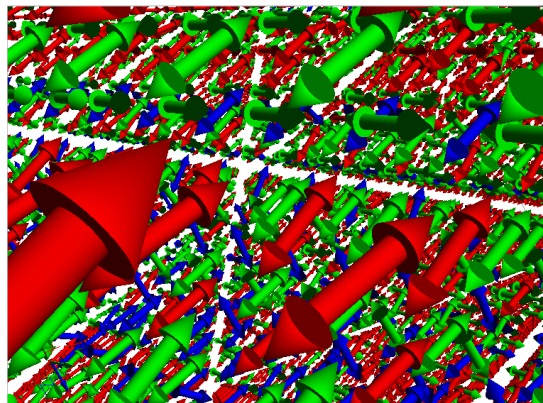

Linear - red

$$c_l = \frac{\lambda_1 - \lambda_2}{\lambda_1 + \lambda_2 + \lambda_3}$$

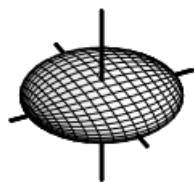

Planar - green

$$c_p = \frac{2(\lambda_2 - \lambda_3)}{\lambda_1 + \lambda_2 + \lambda_3}$$

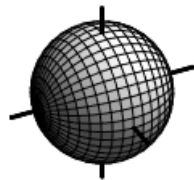

Spherical - blue

$$c_s = \frac{3\lambda_3}{\lambda_1 + \lambda_2 + \lambda_3}$$

From the pull-down menu **Visible on Material IDs** select in which material IDs the volume field is visualized.

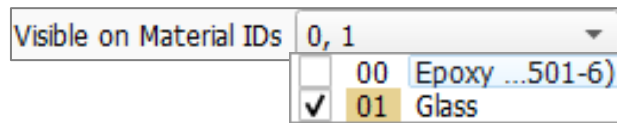

Clip the particle visualization area by selecting a **Clip Direction**, enabling **Clip** and moving the corresponding sliders or entering clipping values.

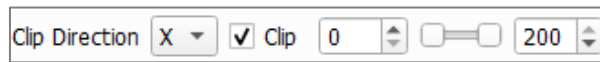

Otherwise, in the **Visualization Settings** dialog, use the option **Data View ▶ Particles ▶ Visibility ▶ Clipping**, working the same way as described for the Volume Field on page [67](#).

Control the **Spacing** between the tensors in the three directions. Smaller spacing leads to smaller tensors, while larger values for spacing results in larger tensors.

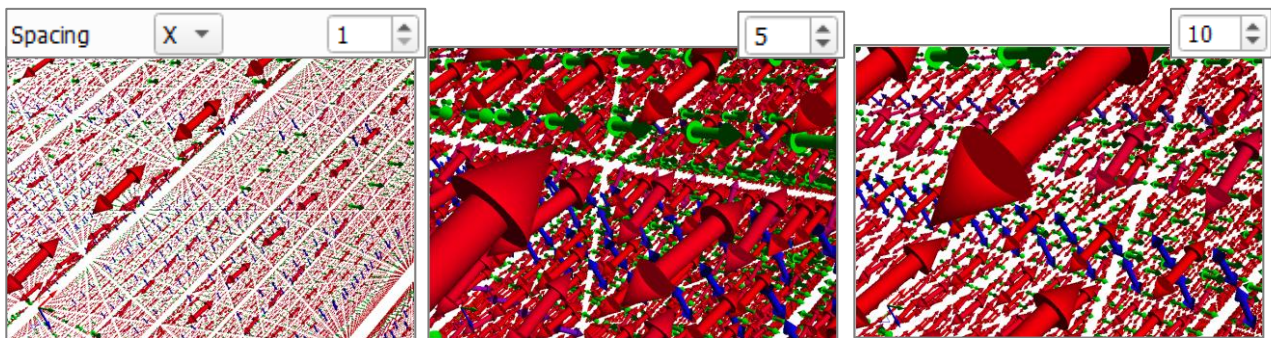

TRIANGLES

For structures with surface meshes in stl format, e.g. a cylindrical pleat generated with **PleatGeo** or structures imported with **ImportGeo-CAD** the **Triangles** tab becomes available.

These options are described in the [ImportGeo-CAD](#) handbook of the User Guide.

LEGENDS AND OVERLAYS

If a structure or a volume field are loaded to **GeoDict**, the settings of all legends and overlays in the **Visualization area** can be changed. For this, open the **Visualization Settings** dialog by clicking the **Visualization tab** in the GUI **Sidebar** and unfold the section **Legends / Overlays**.

Unchecking the box for a legend or overlay option disables the corresponding legend or overlay.

Different options are available for **2D Mode** and **3D Mode**.

Tooltips guide the user through the parameters of the **Legends / Overlays** section.

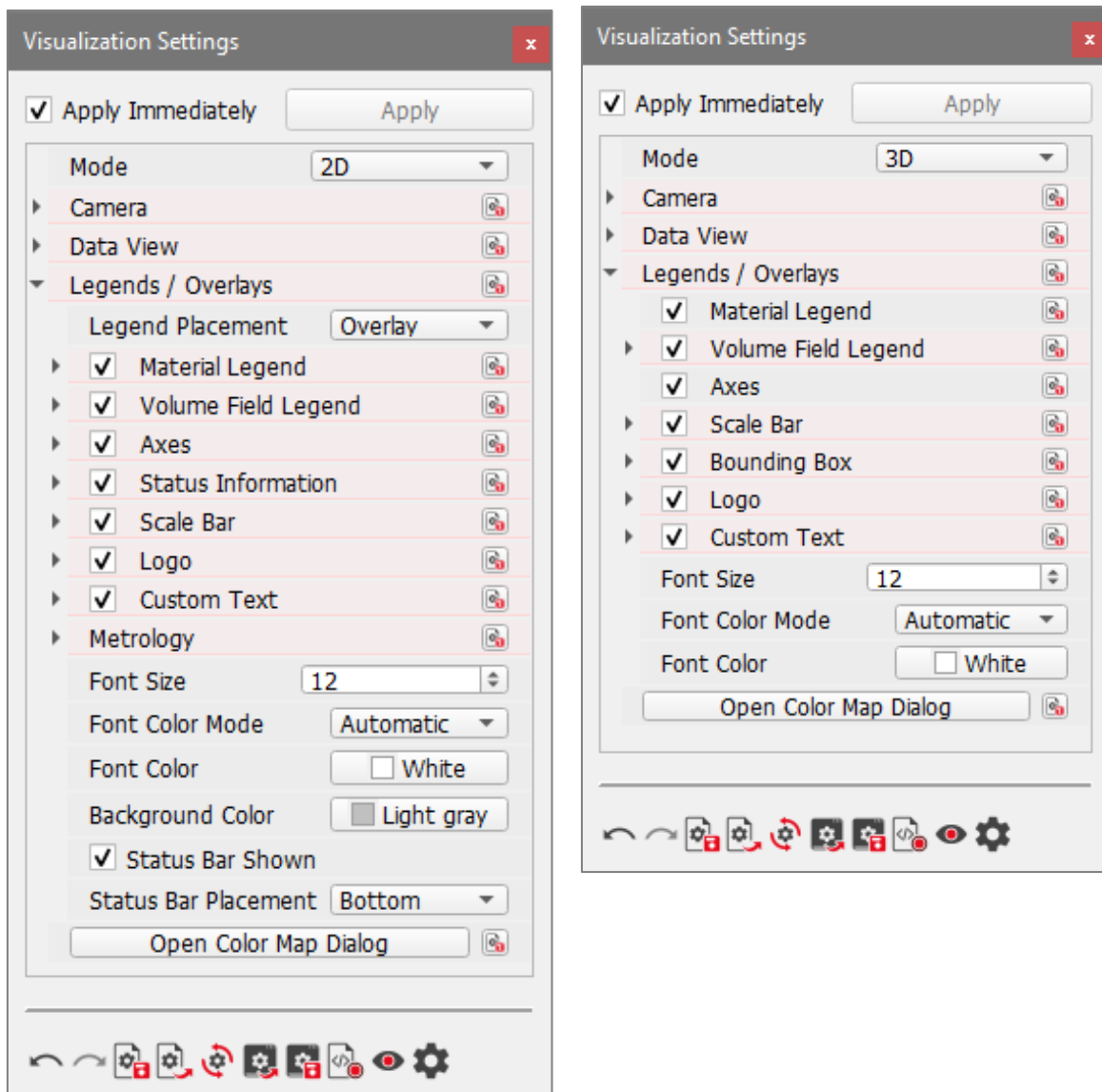

LEGENDS AND OVERLAYS FOR 2D MODE

Decide, if the **Legend Placement** should be **Overlay** or **Attached**. This option is also available in the **Camera** tab of the **View Controls** and is described on page [23](#).

Change the **Font Size** for all legends by entering the desired value. Also, the **Font Color Mode** can be changed from the default **Automatic** to **Manual**. If set to **Manual**, a custom **Font Color** can be chosen. The automatic mode only affects the material legend and the volume field legend. The status bar contents stay white.

Change the **Background Color** of the **Visualization area**, if needed.

Decide whether the **Status Bar** should be **Shown** and select the **Status Bar Placement** to be at the **Bottom** or **Top** of the visualization area.

For all legends and overlays unfolding the corresponding sections gives access to more changeable settings.

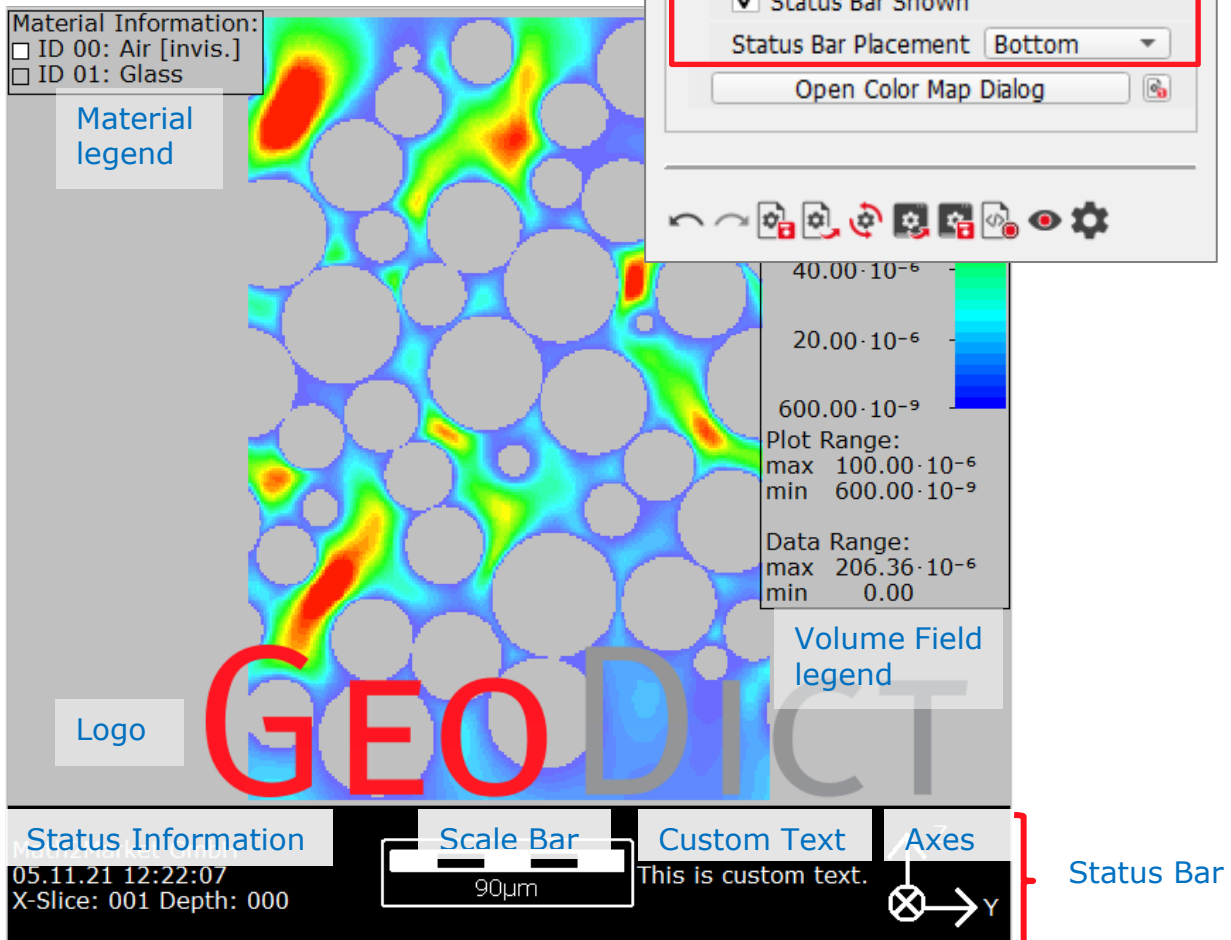
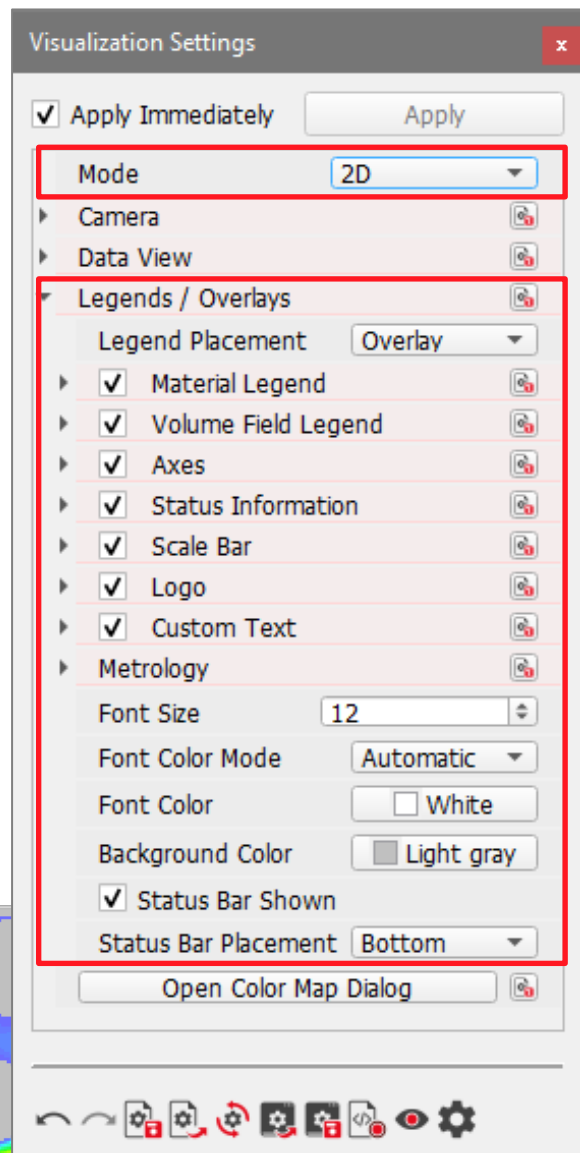

MATERIAL LEGEND

The **Material Legend** shows which materials are contained in the loaded structure.

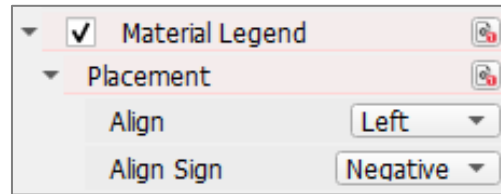

Control the legend's **Placement** with the parameters **Align** and **Align Sign**. **Align** controls, if the legend is placed at the **Left**, **Right**, **Top** or **Bottom** area of the visualization area and **Align Sign** controls where exactly in this area the legend is placed.

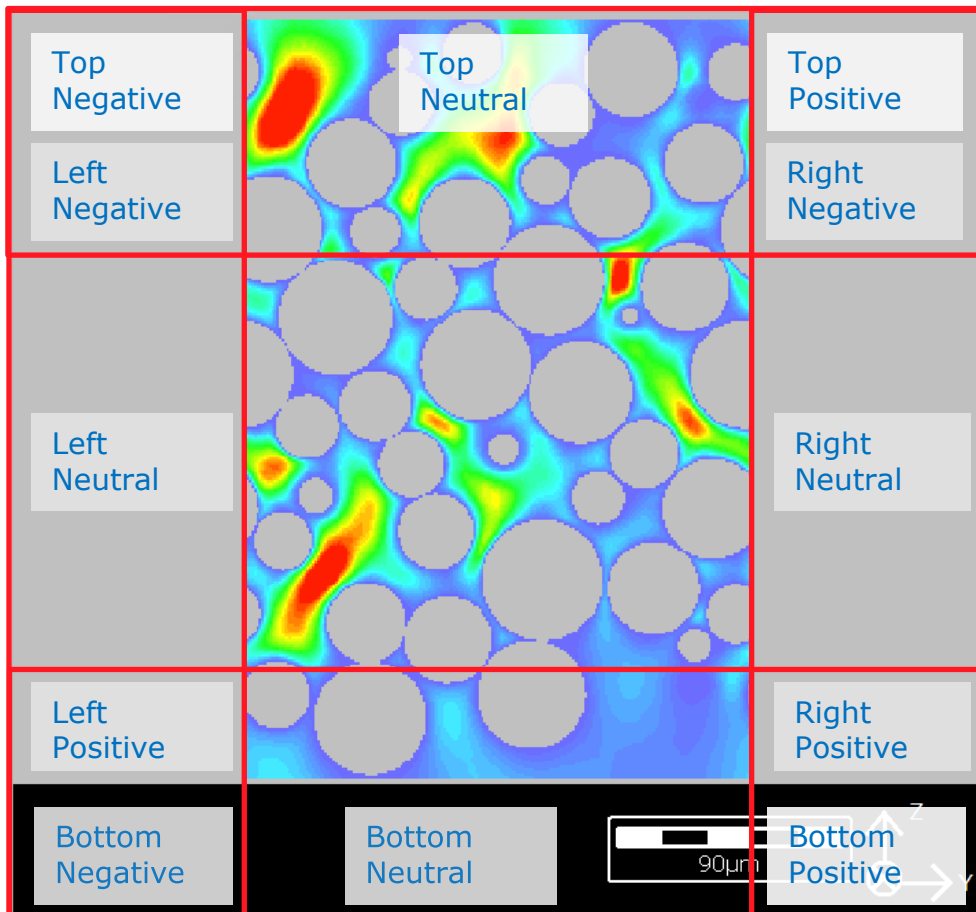

VOLUME FIELD LEGEND

The following explains the functionality of the **Volume Field Legend** parameters.

Control the size of the legend by changing the value for **Stretch**. Enter values between 0 and 1. This parameter depends on the total GeoDict GUI size. Thus, a **Stretch** of 1 would be the as wide or high (depending on the legend placement) as the GeoDict window. If the **Stretch** is chosen too high for the visualization area, the legend is not displayed anymore. Thus, it is recommended to choose values between 0.2 and 0.6.

The value in **Decimals** determines the number of digits shown after the decimal point.

Number Format controls the numbers' display in the legend. Choose between **Number**, **Scientific**, and **Engineering**.

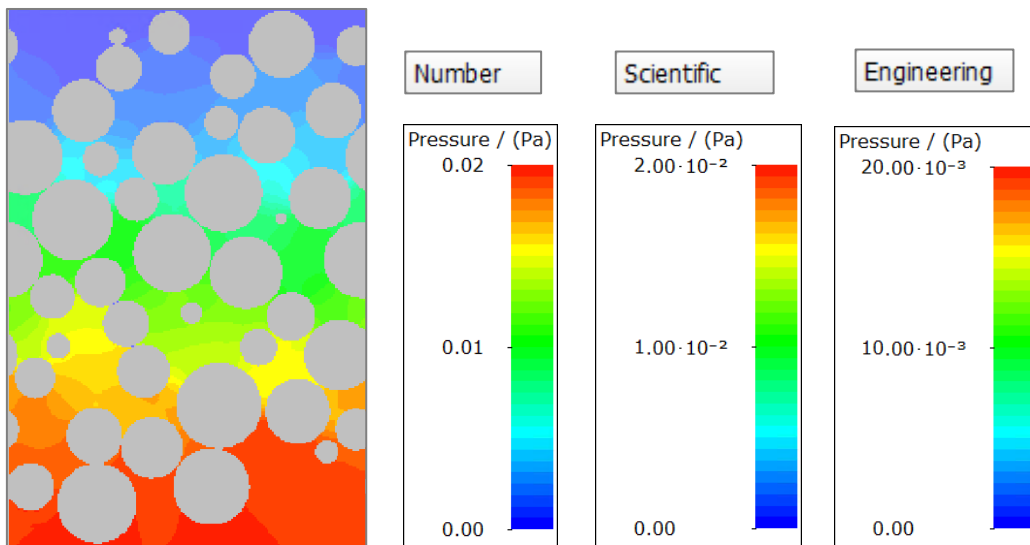
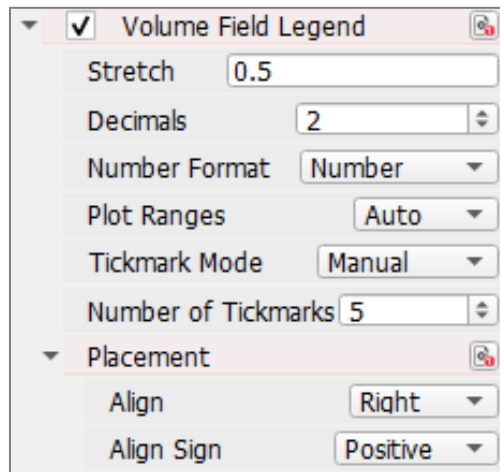

The choice of **Plot Ranges** controls how to display the spread of the data in the result legend. Decide to display **Both**, only the **Plot** or the **Data** range, **None** of the two ranges, or set it to **Auto** (Automatic), which shows both ranges.

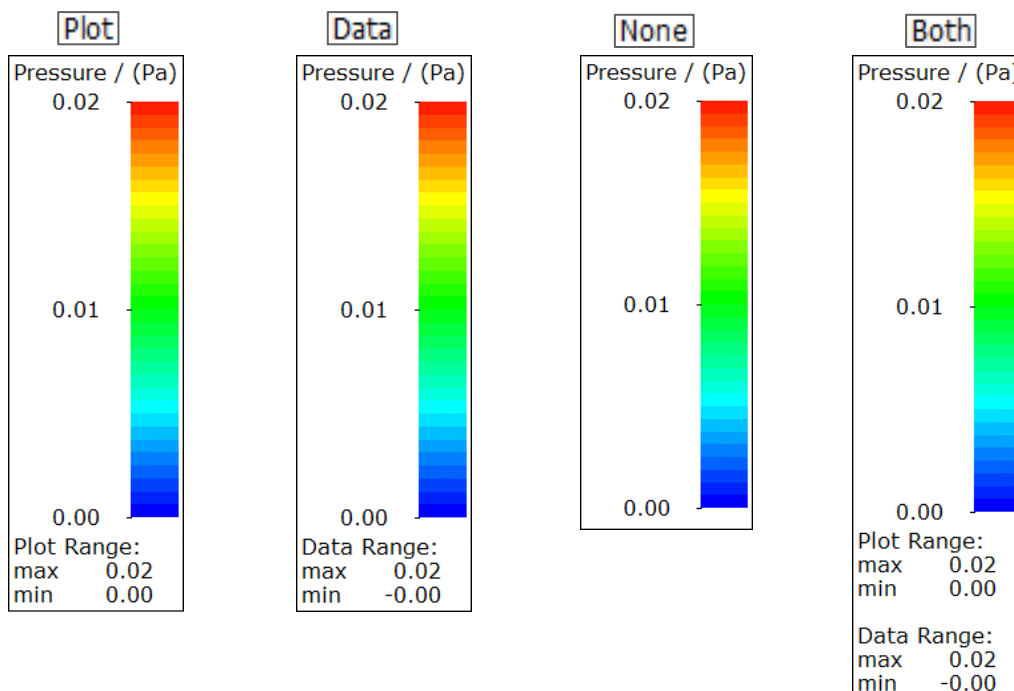

The **Tickmark Mode** controls whether the selection of the number of tick marks in the legend should be **Manual** or **Automatic**. If set to **Manual** enter a desired **Number of Tickmarks**. As the tickmark numbers must be "nice numbers", the tickmark number then is set to a number near the entered value, still resulting in nice numbers.

The **Placement** works as described on page [91](#) for the **Material Legend**.

AXES AND LOGO

The **Placement** of these overlays works as described on page [91](#) for the **Material Legend**.

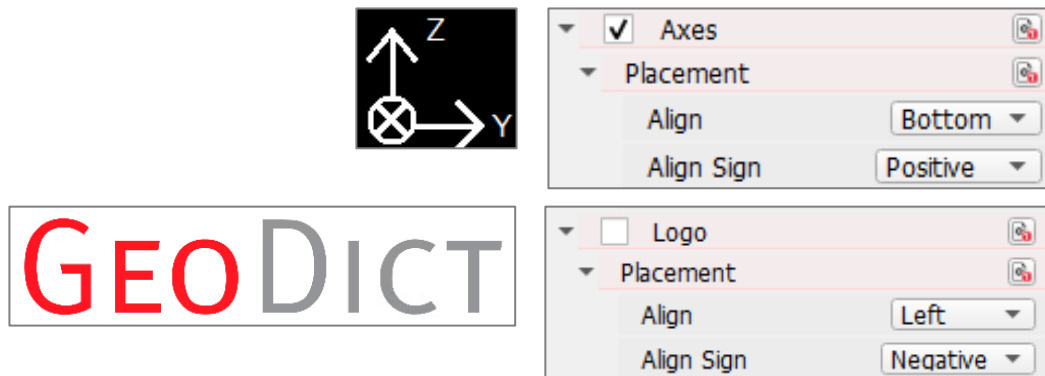

STATUS INFORMATION

Decide which **Status Information** should be shown. The **Placement** for this legend works as described on page [91](#) for the **Material Legend**.

Math2Market GmbH
02.01.24 11:39:09
X-Slice: 001 Depth: 000

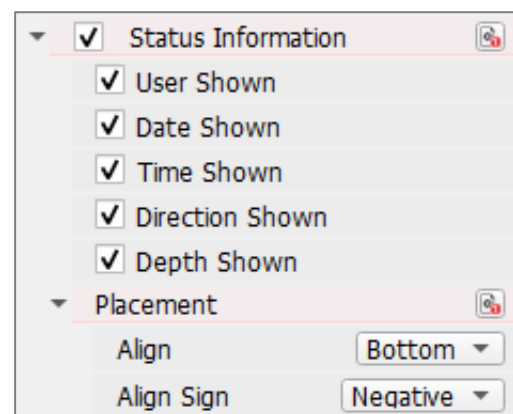

SCALE BAR

Select the **Mode** to be **Percentage** or **Fixed Size**.

If **Percentage** is selected, enter a **Relative Size** or change the value with the slider. This value then determines the size proportional to the length of the structure.

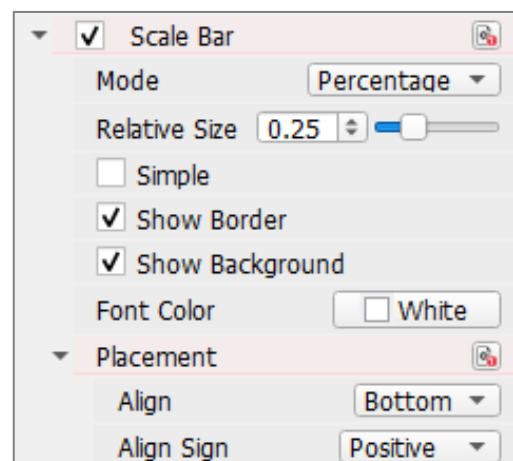

If **Fixed Size** is selected, enter a **Fixed Size** and choose a **Unit**.

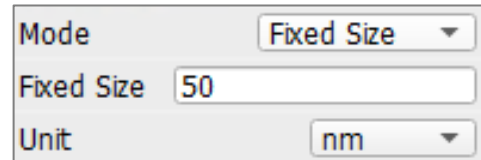

Enable **Simple** to display the scale bar with simple lines.



Select **Show Border** to display the rectangle around the scale bar.

Unchecking **Background** turns the black background of the scale bar invisible.

Also, the **Font Color** can be changed as desired.

The **Placement** for this legend works as described on page [91](#) for the **Material Legend**.

CUSTOM TEXT

Enter a custom **Text** to be shown in the visualization area.

The **Placement** for this overlay works as described on page [91](#) for the **Material Legend**.

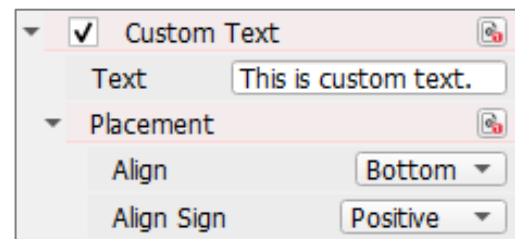

METROLOGY

For **Metrology**, select the **Line Thickness** and the **Line Color**.

Refer to the [GUI, Menu, and Toolbar Reference](#) handbook of the User Guide for more details about the **Metrology** feature.

LEGENDS AND OVERLAYS FOR 3D MODE

Change the **Font Size** for all legends by entering a value. Also, the **Font Color Mode** can be changed from the default **Automatic** to **Manual**. If set to **Manual**, a custom **Font Color** can be chosen.

For **Material Legend** and **Axes** only select if they are shown or not and change the font size and font color as desired.

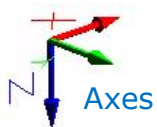
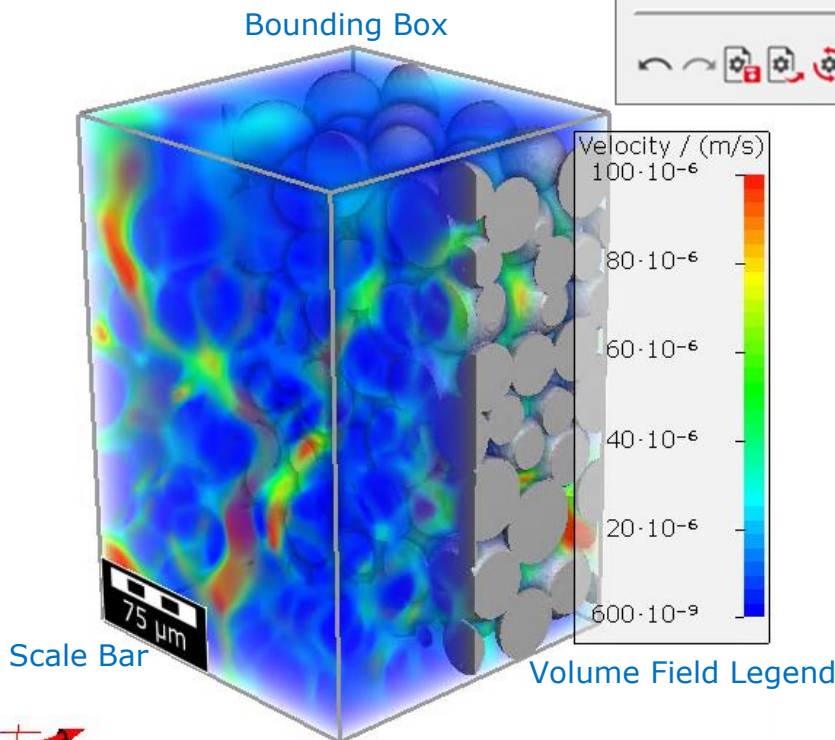
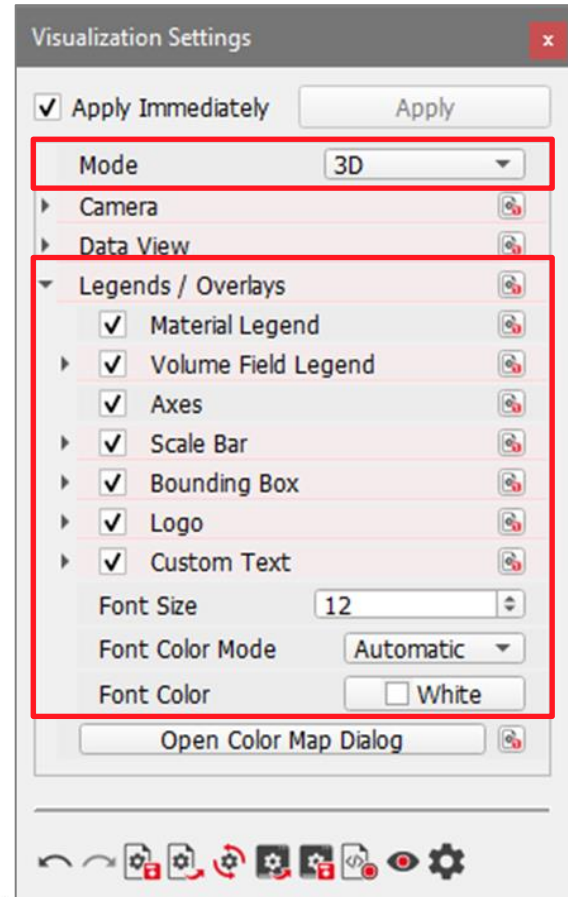

Custom Text
This is custom text.



For all other legends and overlays, unfolding the corresponding sections gives access to more changeable settings.

VOLUME FIELD LEGEND

For the **Volume Field Legend** options refer to the 2D options on page [91](#).

Only the legend placement differs, as for the 3D mode, only the **Align** menu is available with the options **Left**, **Right**, **Top**, and **Bottom**. The volume field legend will always be placed in the center of the selected area.

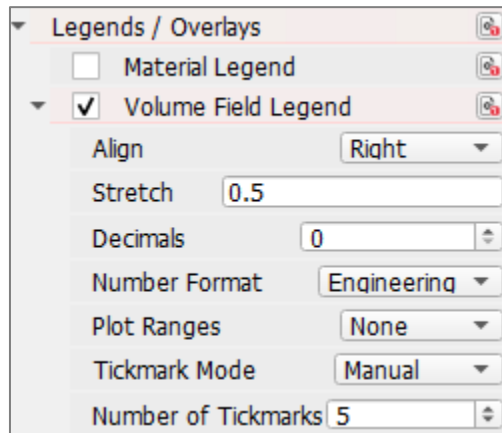

While it is displayed vertically for **Left** and **Right**, it is displayed horizontally for **Top** and **Bottom**.

When selecting a position interfering with the **Material Legend**, the material legend is moved to another position automatically.

SCALE BAR

In 3D mode, the **Scale Bar** can be placed on the structure according to the three **Axes (X, Y and Z)**. **Minus** then places the scale bar on the origin side of the specified axis and **Plus** on the opposite side.

Then, rotate the scale bar as desired, by changing the **Orientation**.

The scale bar can be **Aligned** in the **Bottom Left**, **Bottom Right**, **Top Left** or **Top Right** of the specified structure side.

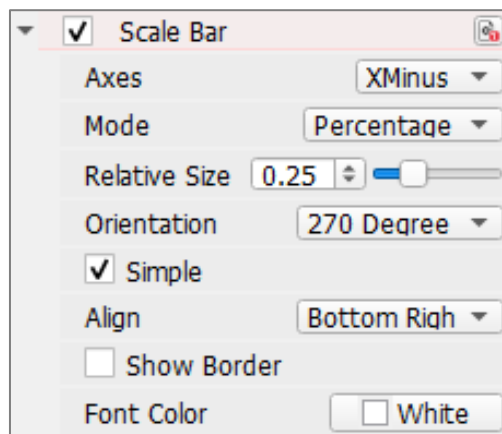

In the following example, the scale bar position is set to default, i.e. the **Plus** side of the **Z**-axis at the **Bottom Left**, with a **0 Degree Rotation**.

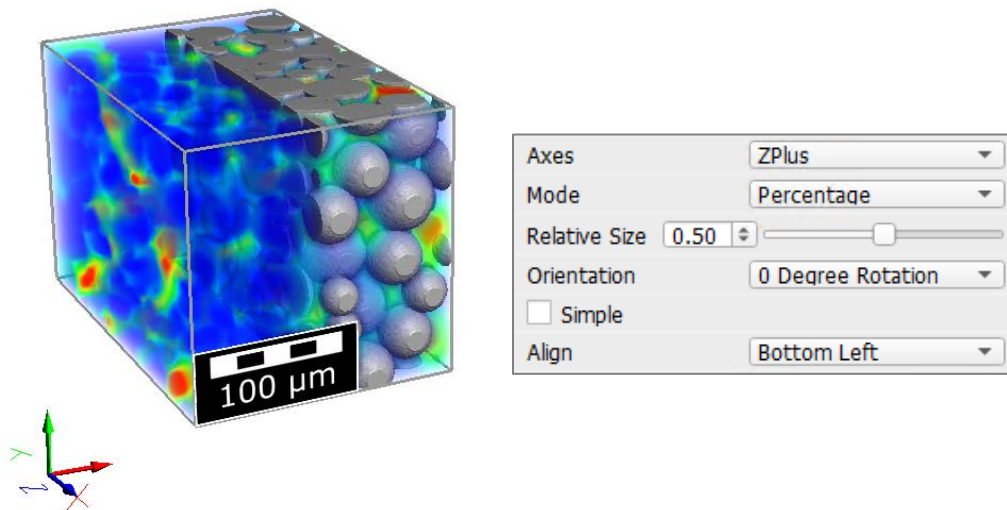

Other positions may be better if the structure is rotated differently. In the following figure, the **Minus** side of the **Y**-axis is turned to the front. Thus, selecting **YMinus** for **Axes** lets appear the scale bar in the front again. But without changing the **Orientation**, it is displayed upside down in the upper right corner of the YMinus side.

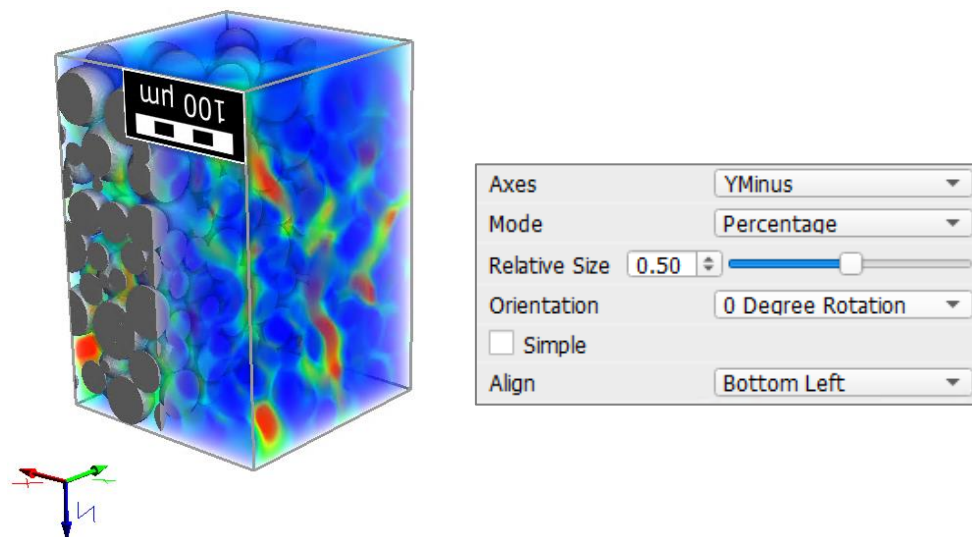

Changing the **Orientation** to **180 Degree Rotation** turns the scalebar about 180 degrees. Additionally, selecting **Top Right** moves the scale bar to the top right from the structures perspective, in this case resulting in a bottom left position from the viewer's perspective.

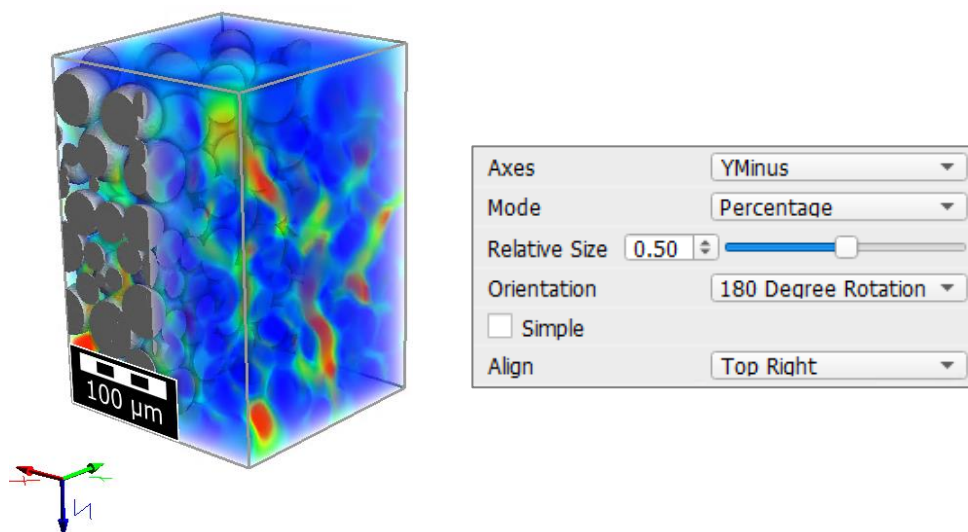

Setting the **Axes** to **Auto** always places the legend on the front of the structure in the correct orientation.

The other available options for **Scale Bar** are described for the 2D mode on page [93](#).

BOUNDING BOX

If **Bounding Box** is enabled, the structure's domain border indicators are displayed. Change **Thickness** and **Color** as desired.

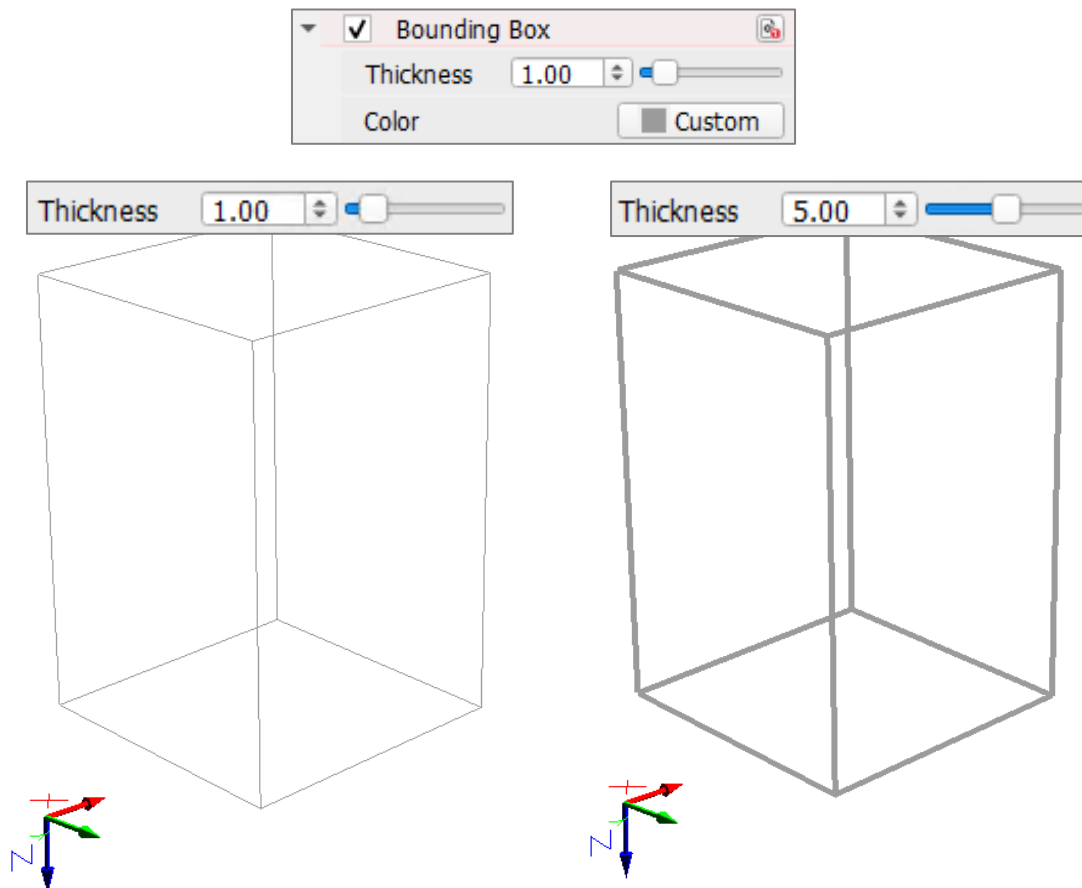

LOGO

The **GeoDict Logo** can be **Aligned** in the **Bottom Left**, **Bottom Right**, **Top Left** or **Top Right** corners of the visualization area.

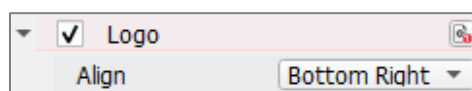

CUSTOM TEXT

The **Custom Text** parameters are the same as for the 2D mode.

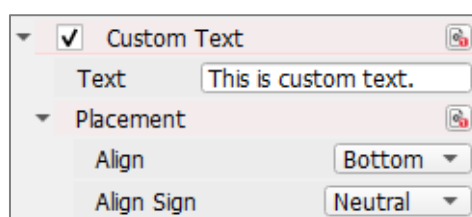

REFERENCES

- [1] Kindlmann, G., Superquadric Tensor Glyphs, Eurographics / IEEE VGTC Symposium on Visualization: 147-154 (2004), <http://dx.doi.org/10.2312/VisSym/VisSym04/147-154>

Technical
documentation:

Janine Hilden
Barbara Planas

MATH
2 MARKET

Math2Market GmbH
Richard-Wagner-Str. 1, 67655 Kaiserslautern, Germany
www.geodict.com

© Fraunhofer Institut Techno- und Wirtschaftsmathematik ITWM, 2003-2011.
© Math2Market GmbH, 2011-2023. All rights reserved.